

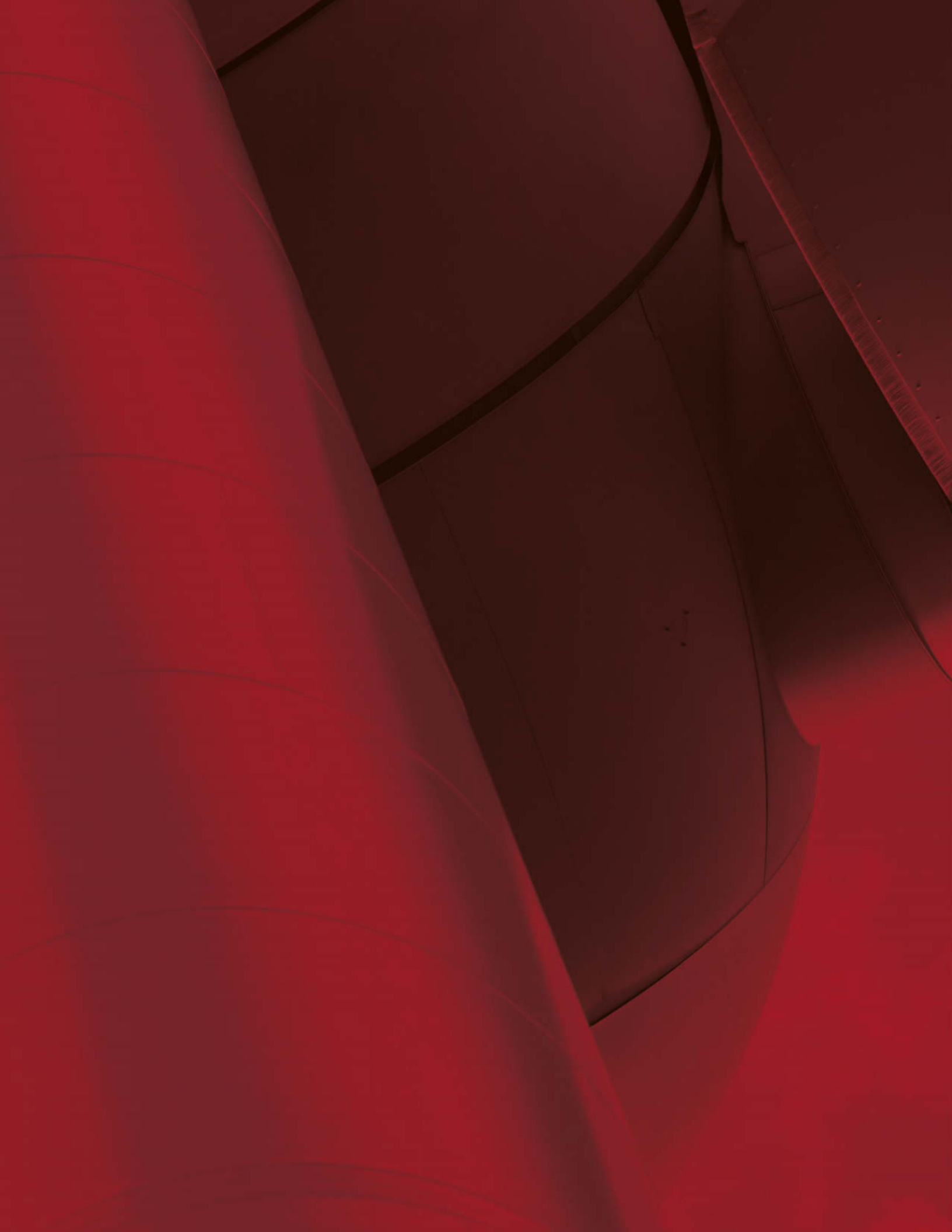

# NSK

ADVANCED BEARING SOLUTIONS FOR  
THE WIND INDUSTRY







Wind turbines generate electricity under adverse and constantly changing conditions, both on and offshore. Efficient power generation from wind turbines demands high performance from every component – particularly the bearings used in the turbine drivetrain and gearbox.

NSK rolling bearings for these applications perform with robust resistance to seizure, wear, flaking and unique challenges such as white etching cracks (WEC) to deliver advanced product design solutions for a reliable and sustainable operating life.

# A GLOBAL PARTNER AND SOLUTIONS PROVIDER

As a leading manufacturer of rolling bearings, linear technology components and steering systems, NSK can be found on almost every continent – with production facilities, sales offices and technology centers – providing our customers with responsive decision-making channels, effective logistics and local service.



## THE NSK COMPANY:

NSK commenced operations as the first Japanese manufacturer of rolling bearings in 1916. From the outset, we have been continuously expanding and improving not only our product portfolio but also our range of services for various industrial sectors. In this context, we develop technologies in the fields of rolling bearings, linear systems, components for the automotive industry and mechatronic systems. Our research and production facilities in the Americas, Europe and Asia are linked together in a global technology network. Here we concentrate not only on the development of new technologies, but also on the continuous optimization of quality – at every process stage.

	THE AMERICAS	EUROPE / AFRICA	ASIA / OCEANIA
MANUFACTURING SITES	9	9	46
SALES LOCATIONS	21	15	83
TECHNOLOGY CENTERS	2	3	10



NSK has a long tradition in patent applications for machine parts. In our worldwide research centers, we not only concentrate on the development of new technologies, but also on the continual improvement of quality based on the integrated technology platform of tribology, material technology, numerical simulation and mechatronics.

#### TRIBOLOGY:

**Improving Performance by Optimizing Friction.** Tribology is the study of friction and wear of contact surfaces in relative motion, such as rotating parts that endure enormous forces with a thin oil film. Severe operating conditions are optimized through lubrication and surface treatments developed by NSK, resulting in superior performance for applications requiring low friction, high-speed rotation, quiet operation or enhanced durability.

#### MATERIALS:

**Superior Performance for Any Application.** Materials research and development affects nearly every aspect of product performance. Through careful selection of material composition, heat treatment and use of alternative materials, NSK enables optimization of application performance. This may be through improvements in product function, endurance, and reliability or through improvements in production and process cost efficiency.

#### NUMERICAL SIMULATION:

**Turning Blind Risk Into Trusted Reliability.** In the past, accuracy and reliability in product development were achieved with experience-based design and longer testing periods. NSK's simulation technology allows for virtual validation to accelerate design and production. Extreme conditions or innovative designs that defy previous expectations can also be evaluated and analyzed.

#### MECHATRONICS:

**Technology for a Safe and Comfortable Future.** Mechatronics refers to the combination of mechanics and control technologies. NSK has cultivated knowledge of mechanics through years of product development and production. This knowledge is used in conjunction with motors, sensors and circuits to develop mechatronic systems that add new functions, improve reliability and increase performance in various industries while also improving convenience and safety in our daily lives.



# EVERY SOLUTION CALLS FOR THE RIGHT PRODUCTS

Whether for the main drive stage or accessories, our broad range of rolling bearing products deliver reliable and sustainable operating life for a wide variety of applications.

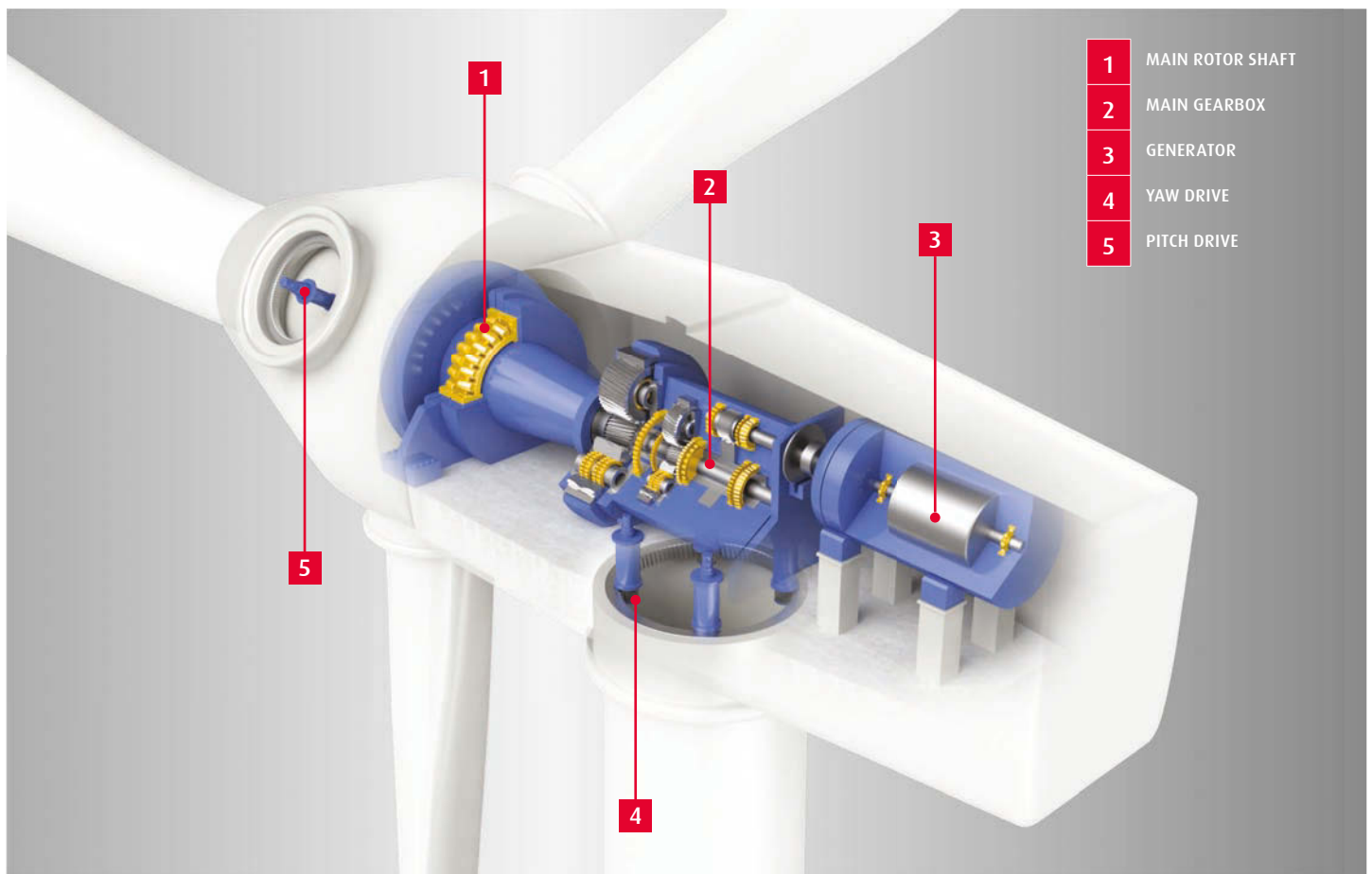

## MAIN ROTOR SHAFT

The rotor induces high axial and radial loads in the main bearings, which occur both statically and dynamically. Given such loads as these, high bearing stiffness is indispensable. Spherical roller bearings used in the 3 point drivetrains, or cylindrical and tapered roller bearings used in the modular drivetrain, are particularly well-suited for this application.

## MAIN GEARBOX

A variety of gearbox arrangements have been implemented for wind turbines in recent years. Megawatt-class systems often combine planet gear stage(s) with multiple parallel gear stages. Deep groove ball bearings, spherical roller bearings, cylindrical roller bearings, tapered roller bearings and four-point contact ball bearings are used, depending on the location of the bearing.

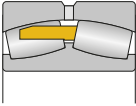
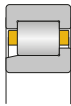
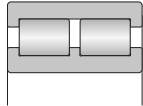
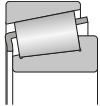
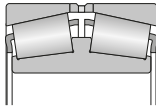
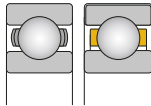
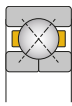
	SPHERICAL ROLLER BEARINGS	CYLINDRICAL ROLLER BEARINGS - SINGLE ROW	CYLINDRICAL ROLLER BEARINGS - DOUBLE ROW	TAPERED ROLLER BEARINGS - SINGLE ROW	TAPERED ROLLER BEARINGS - DOUBLE ROW / DUPLEX	DEEP GROOVE BALL BEARINGS	FOUR-POINT BEARINGS
							
MAIN ROTOR SHAFT	■	■		■	■		
MAIN GEARBOX	■	■	■	■	■	■	■
GENERATOR		■				■	
PITCH / YAW GEARBOX	■	■		■		■	

### GENERATOR

Generators primarily use deep groove ball bearings and cylindrical roller bearings. Transmission of electrical current can damage the rolling bearings and shorten their service life. In order to avoid this damage, the use of insulated rolling bearings should be considered. NSK offers coated rolling bearings where an insulating coating has been applied to the outer rings.

### PITCH AND YAW GEARBOX

Yaw gearboxes turn the nacelle into the wind or away from it. Pitch gearboxes are required for rotor blade adjustment. Deep groove ball bearings, cylindrical roller bearings, spherical roller bearings and tapered roller bearings are typically installed in these gearboxes.

# MAIN SHAFT BEARINGS



## 3-POINT SUSPENSION

One of the most common wind turbine architectures is the 3-point suspension. In this configuration, a single main spherical roller bearing is used to support the main shaft and wind loading. The other end of the main shaft is rigidly mounted to the input shaft of the gearbox and relies on the gearbox's flexible trunion system to share the loading through the gearbox's input shaft bearings. All of the wind loading generated by the rotor, as well as its torque, must be safely transmitted through the gearbox structure and mounting system to the wind turbine's frame.

**Bearing Selection: Spherical Roller Bearing, CA Design**

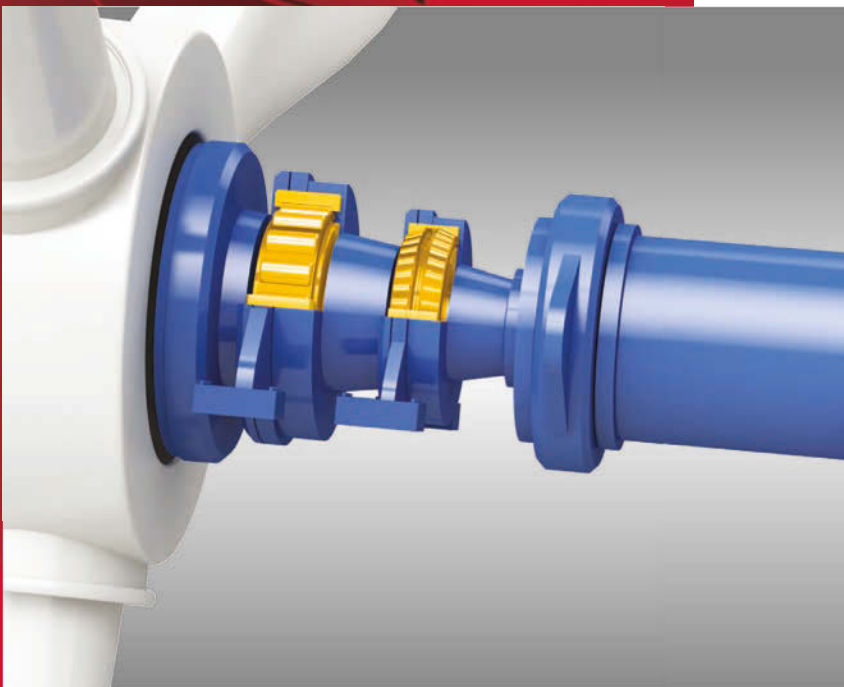

## MODULAR DRIVETRAIN

The modular drivetrain architecture is a typical configuration consisting of two main bearings that support a separate main shaft. This main shaft is also rigidly connected to the gearbox input shaft. The bearings supporting the main shaft isolate the wind loading from the gearbox and its bearings. Only deflections and tolerances may cause additional reaction loads in the gearbox bearings. Often the reaction loads at the bearings cannot easily be calculated in this statically indeterminate drivetrain configuration.

**Bearing Selection: Tapered Roller Bearing, Single Row or Double Row KDH or KH Design**

**Cylindrical Roller Bearing Single Row NU, NJ or NF Design**





### **SPHERICAL ROLLER BEARING CA DESIGN**

CA series spherical roller bearings with heavy duty machined brass cage have extremely high load capacity and superior durability. With optimized internal geometry, they are especially suitable for applications with heavy loads, shock conditions and misalignment, delivering high performance in large rotor shaft arrangements even at low speeds. Available with Super-TF long-life steel.



### **TAPERED ROLLER BEARINGS DOUBLE ROW**

NSK double-row tapered roller bearings are designed with a single inner ring, 2 roller/cage sets and 2 outer rings with spacer. Optimized large-size rollers guided by high strength, wear resistant cages deliver high capacity for combined heavy radial loads and axial loads in both directions. In inch and metric dimensions with normal contact angle (KH design) or with steep angle races (KDH design) for increased axial load capacity. Available with Super-TF long-life steel.



### **CYLINDRICAL ROLLER BEARINGS SINGLE ROW**

Optimized size and profile of rollers guided by high precision machined cages deliver higher load ratings and smooth rotation in main shaft applications, even at very low speeds. With heavy duty precision machined brass cage or pin-type cages. Available with Super-TF long-life steel.

# MAIN GEARBOX BEARINGS

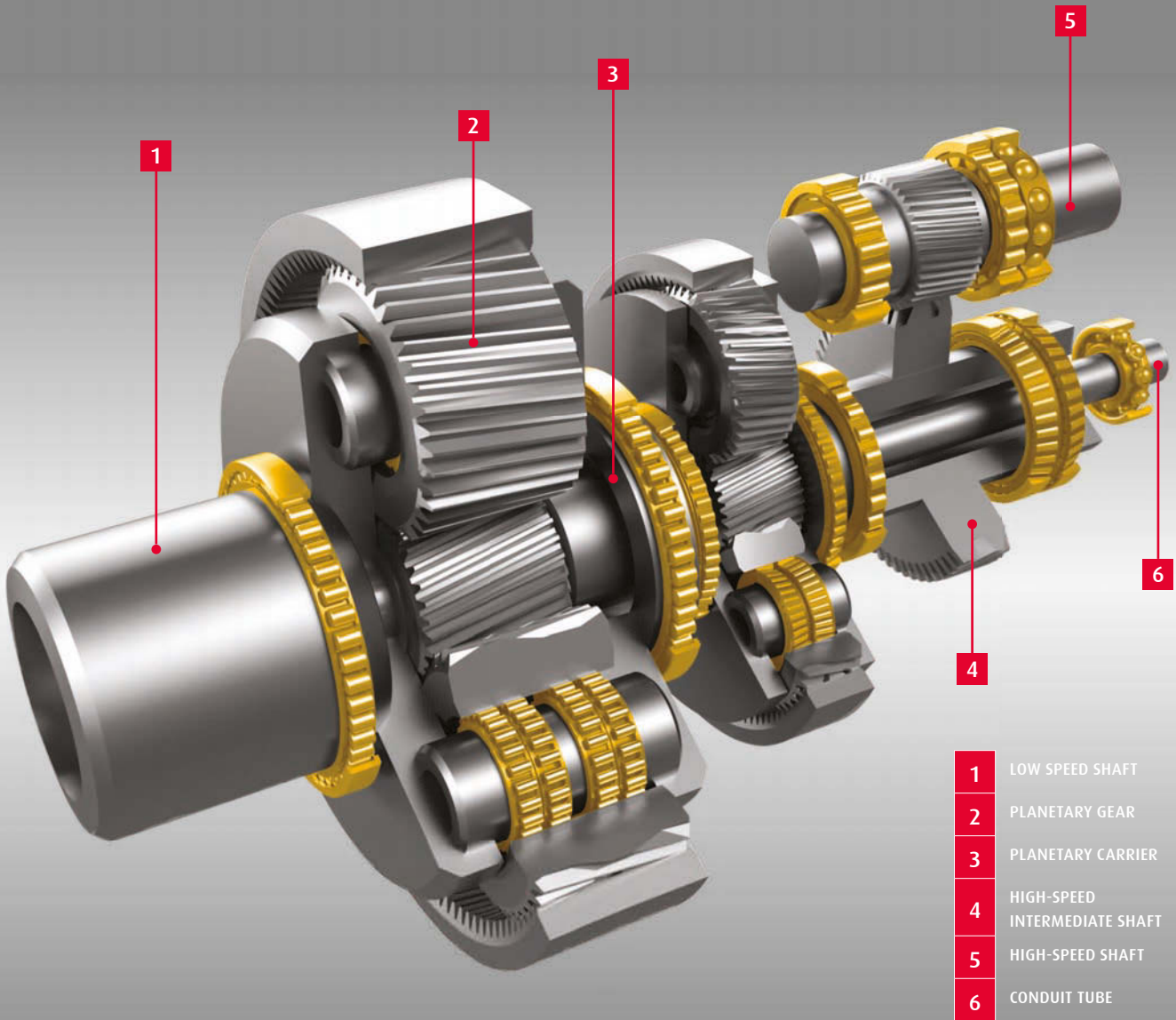

Through close collaboration with our wind industry partners, NSK has gained tremendous insight into the complex conditions that impact wind turbine operation – none more profoundly than within the gearbox. Our advanced product development takes into consideration the continuous variation and fluctuation of factors such as lubrication, loads, stresses, vibrations and temperatures to deliver reliable and cost-effective operating life.



### CYLINDRICAL ROLLER BEARINGS, FULL COMPLEMENT

Cage-less full complement cylindrical roller bearings have the maximum possible number of rollers and can sustain much heavier loads than cylindrical roller bearings of the same size with cages. In single row NCF and double row NNCF series. Available with Super-TF long-life steel and black oxide coating.

**Bearing Location:** Planetary Carrier  
Planetary Gear



### CYLINDRICAL ROLLER BEARINGS, SINGLE ROW

Featuring NSKHPS high performance standard for increased load capacity and speed ratings, NSK single row cylindrical roller bearings deliver high strength and radial rigidity for high loads and speeds. Optimized internal geometry promotes lower running temperature and quiet operation. Available with AWS-TF long-life steel specialized to prevent white etching cracks. Also available with Super-TF long-life steel and black oxide coating.

**Bearing Location:** High-Speed Intermediate Shaft  
High-Speed Shaft

### NSKHPS CYLINDRICAL ROLLER BEARINGS, EM CAGE

- > Bearing life increased as much as 2x compared to conventional designs
- > As much as 23% higher basic load rating
- > High strength and maximum rigidity for high loads and high speeds
- > Higher permissible misalignment

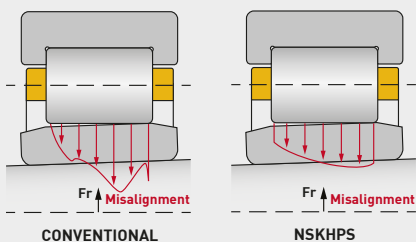

	C <sub>r</sub>	LIFE	PERMISSIBLE MISALIGNMENT	
			22XXE, 23XXE	2XXE, 3XXE
Conventional	1	1	2'	4'
NSKHPS	1.23	2	4'	4'

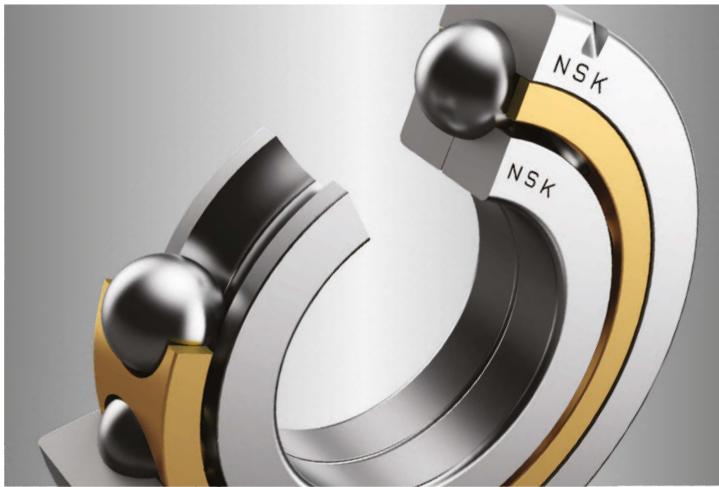

### FOUR-POINT CONTACT BALL BEARINGS

Four-point ball bearings are designed with a 35° contact angle and an inner ring that is split radially into two pieces. Cage is machined brass. Their design allows one bearing to sustain significant axial loads in either direction with high capacity. They are capable of accommodating pure axial loads or combined loads where the axial load is higher. Available with Super-TF long-life steel and black oxide coating.

**Bearing Location: High-Speed Intermediate Shaft  
High-Speed Shaft**



### DEEP GROOVE BALL BEARINGS

NSK Deep Groove Ball Bearings are designed to deliver unsurpassed performance for a wide variety of applications. Precision high-grade balls and super-finished raceways provide smooth and quiet operation. For low to medium radial loads and smaller axial loads in both directions. Advanced lubricant technology and sealing designs ensure optimum performance and reliability. Available in NSKHP series with pressed steel cage or machined brass cage.

**Bearing Location: Conduit Tube**

### BLACK OXIDE COATING (BOC)

Black oxide coating is an effective surface treatment to counteract bearing damage due to slippage that occurs typically during start-up. It can be used in all main gearbox bearing locations for optimum protection and performance.

### FALEX TEST

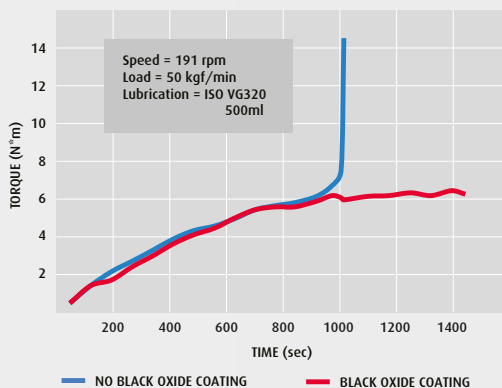



### TAPERED ROLLER BEARINGS, DUPLEX

Duplex tapered roller bearing arrangements feature two single row bearings and an outer ring spacer, as equivalent singles or as a major/minor set. They can accommodate heavy radial loads and axial loads in both directions. Available with Super-TF long-life steel or AWS-TF long-life steel specialized to prevent white structure flaking. Also available with black oxide coating.

**Bearing Location:** High-Speed Intermediate Shaft  
High-Speed Shaft  
Low-Speed Intermediate Shaft



### TAPERED ROLLER BEARINGS, SINGLE ROW

Single row tapered roller bearings have high radial and axial rigidity, and are capable of taking high radial loads and moment loads as well as axial loads in one direction. NSK offers a range of large size, dimensionally specialized single row tapered roller bearings for main gearbox applications in both metric and inch configurations. Available with Super-TF long-life steel and black oxide coating.

**Bearing Location:** Planetary Carrier



### TAPERED ROLLER BEARINGS, DOUBLE ROW

Double row tapered roller bearings feature two roller/cage sets and two outer rings with spacer on a single inner ring. They can accommodate heavy radial loads and axial loads in both directions. Available in normal contact angle (KH design) or with steep angle races (KDH design) for increased axial load capacity. Available with Super-TF long-life steel and black oxide coating.

**Bearing Location:** Low-Speed Intermediate Shaft

# GENERATOR BEARINGS



## CERAMIC COATED INSULATING BEARINGS

NSK ceramic coated bearings provide superior insulation properties to prevent electrical erosion or arcing in bearings used in turbine generators. An optimized alumina-based ceramic material combined with a blend of additives is used to coat the outer ring, offering a high resistance to the flow of electrical current. The coating is tough and durable when impacted on its corner surfaces, and possesses excellent heat dissipation properties. Boundary dimensions are identical to a standard bearing, enabling easy replacement without need for modifications.

### Bearing Location: Generator

SPECIFICATION	NSK CERAMIC INSULATION HD2
Application	Generator
Insulating material	Al <sub>2</sub> O <sub>3</sub>
Insulation resistance (1000VDC)	Over 100MΩ
Breakdown voltage	Over 4kV
Boundary dimension	ISO standard

## ADVANCED SOLUTIONS – NSK TOUGH STEEL

The valuation of a wind turbine includes one major maintenance cycle during its 20-year life expectancy. As such, the need for improved durability in bearing performance is a critical consideration to achieve the greatest reliability and total cost performance – even in uniquely demanding operating conditions. In response, NSK has applied our Tough Steel technology to develop bearing solutions that set a new standard for long service life.



NSK's Super-TF (STF) series bearings are designed to deliver outstanding durability in operating environments subject to contamination. Utilizing advanced material engineering and heat treatment technology, they perform with superior resistance to wear and seizure under contaminated lubrication conditions. For the specific challenge of hydrogen induced embrittlement impacting bearings used in turbine gearboxes, NSK has introduced our AWS-TF technology to attack premature bearing failure at the core of its generation: the metallurgy.

Outstanding toughness, performance, and total cost-savings: NSK technology sets a new standard for long service life.

# SUPER TF AND AWS-TF BEARINGS

In its quest for longer bearing service life, NSK has spent many years analyzing the mechanisms of fatigue in bearings and researching and developing materials, heat treatment processes and operating conditions. The range of approaches to achieving longer service life taken by our research team are shown in Fig. 1. The technology incorporated in our AWS-TF and Super-TF Bearings is designed to maximize service life under conditions where bearings are subject to hydrogen induced embrittlement and contamination induced surface-originating flaking.

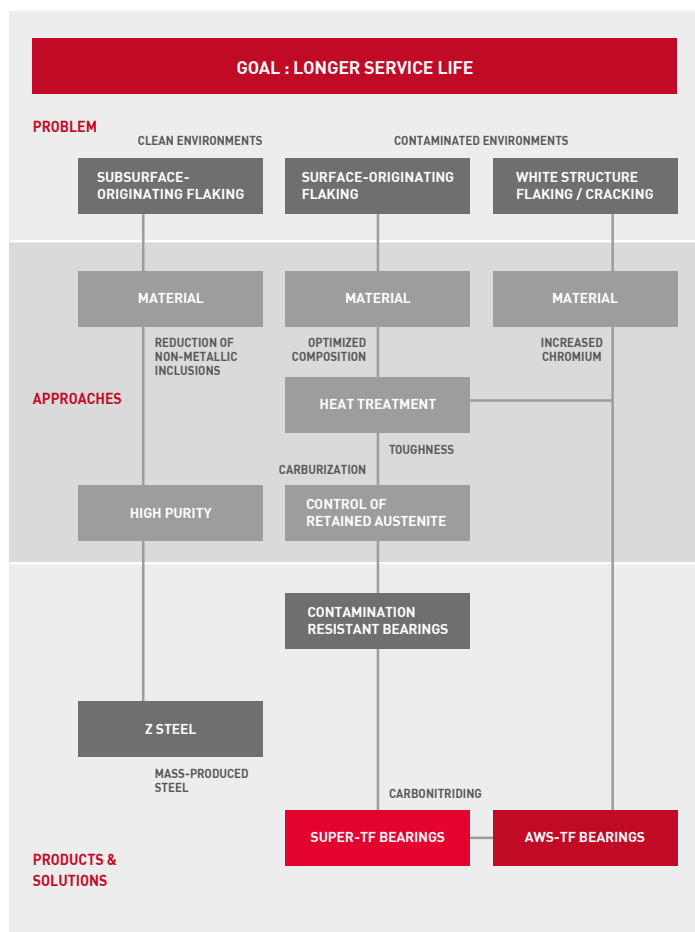

FIG. 1 APPROACHES TO ACHIEVING LONGER SERVICE LIFE FROM BEARINGS

## SUPER-TF AND SURFACE-ORIGINATING FLAKING

Bearings can be required to operate under conditions where lubrication is easily contaminated. Metal particles or casting sand in the lubricant create dents in the rolling contact surfaces, and stress concentrated around these dents eventually leads to cracking and to surface-originating flaking. The ability to reduce the concentration of stress around the shoulders of surface dents is directly related to achieving longer service life from the bearing.

NSK research and development of material properties has revealed that a high level of retained austenite is an extremely effective means of maximizing the r/c value around surface dents in the bearing material (see Fig. 2) - the greater the r/c value, the smaller the stress concentration. TF technology in general is a unique heat treatment process developed by NSK to optimize the level of retained austenite in bearing materials.

However, austenite itself has a soft microstructure, reducing the hardness of the bearing material. To meet the needs for greater hardness with a higher level of retained austenite, NSK adopts a technique to promote the uniform distribution and reduce the diameter of carbide and carbonitride particles in the bearing material. Super-TF bearing steel contains appropriate amounts of chrome and molybdenum to optimize the formation of carbides.

Figures 3 and 4 illustrate that Super-TF Bearings have a greater amount of fine-size carbide and carbonitride particles than ordinary carburized bearings, giving them a greater degree of hardness and higher retained austenite for a long service life.





## AWS-TF AND WHITE STRUCTURE FLAKING

Hydrogen embrittlement is a prevailing bearing failure mode found in wind turbine applications. It is a process by which hydrogen penetrates into the bearing steel, causing it to weaken. Hydrogen itself is generated by typical tribomechanical and tribochemical events occurring to the bearing lubricant during operation of the wind turbine. White structure forms below the surface of the bearing, and this change to the microstructure results in the formation of cracks that will extend to the surface of the bearing under stress concentration during operation. Cracks propagate under the load of each passing roller, leading to flaking and ultimately bearing failure.

With our AWS-TF bearings, NSK has countered white structure flaking by applying the technology of Tough Steel long-life materials. White structure flaking tends to be generated when hydrogen becomes concentrated at stress points. NSK optimizes additional chromium content in our bearing steel composition to significantly decrease the diffusion rate of hydrogen and delay microstructural change, thereby increasing resistance to white structure flaking. In rolling fatigue life tests conducted in hydrogen charged environments, increasing chromium content proves to ensure longer life performance.

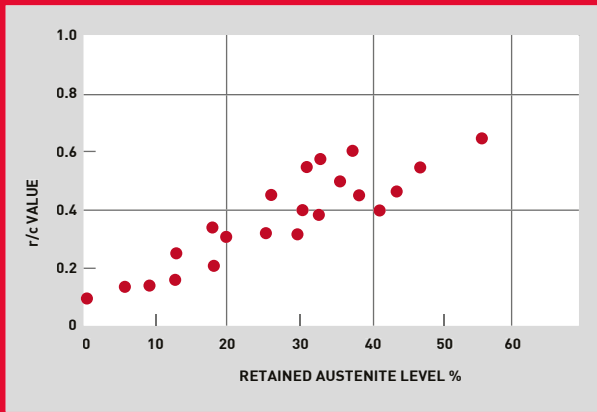

FIG. 2 RELATIONSHIP OF  $r/c$  VALUE TO RETAINED AUSTENITE LEVEL

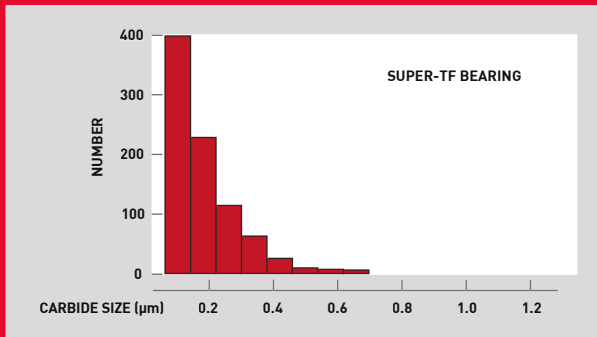

FIG. 3 AVERAGE DIAMETER OF CARBIDE AND CARBONITRIDE PARTICLES IN A SUPER-TF BEARING

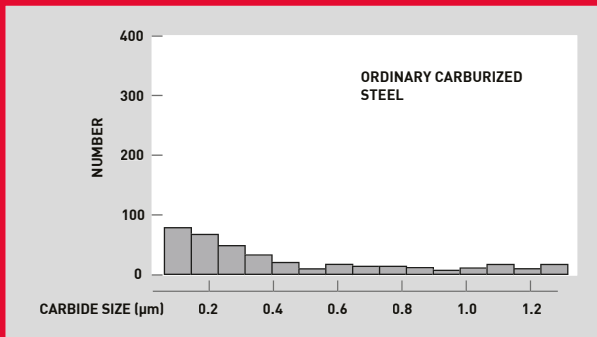

FIG. 4 AVERAGE DIAMETER OF CARBIDE PARTICLES IN AN ORDINARY CARBURIZED STEEL BEARING

# BEARING FAILURE MODES

## SURFACE-ORIGINATING FLAKING



**Location:**  
Gearbox - All Bearing Positions  
Main Shaft

**Solution:**  
Super-TF (STF) Long-life Steel

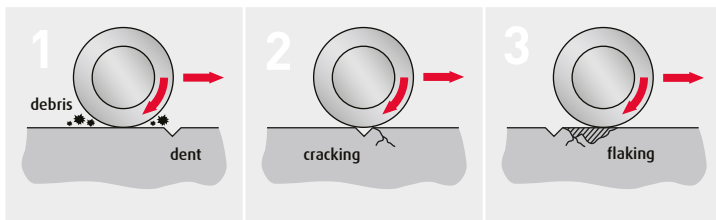

Foreign debris contamination leads to the formation of dents

Stress concentration around debris dents develop into cracks

Cracks propagate under the load of each passing roller and develop into flaking

## COMPARISON OF SERVICE LIFE

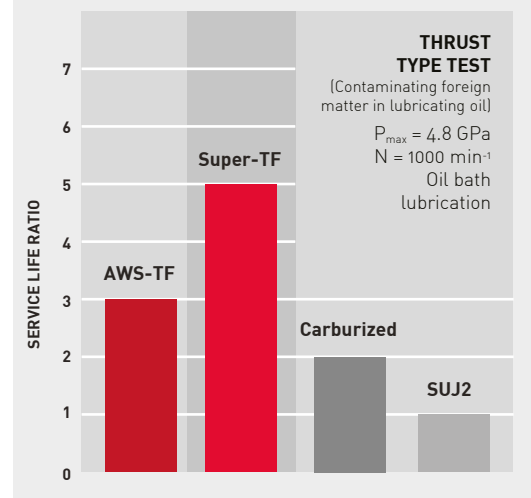

**STF delivers 5 times the life of standard steel (SUJ2), while AWS-TF delivers 3 times**

## SKIDDING

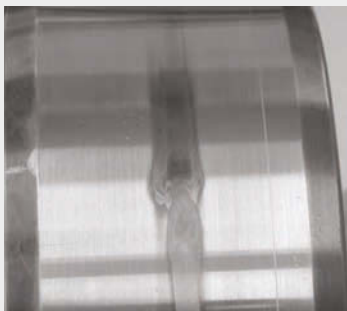

**Location:**  
Gearbox - LSS, HSIMS, HSS

**Solution:**  
Black oxide coating

## ELECTRICAL EROSION



**Location:**  
Generator - rotor bearing

**Solution:**  
Ceramic coating

## WHITE ETCHING CRACKS / FLAKING



**Location:**  
Gearbox - HSIMS, HSS

**Solution:**  
Anti-White Structure TF (AWS-TF)  
Long-life Steel

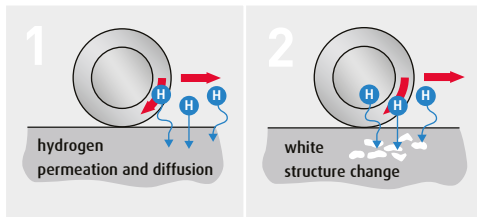

Hydrogen permeates the bearing steel, causing it to weaken

White structure forms below the surface of the bearing

Crack formation begins along the boundary of white structure during repetitive stressing

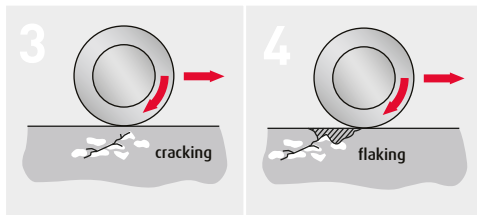

Cracks propagate under the load of each passing roller and develop into flaking

## COMPARISON OF SERVICE LIFE

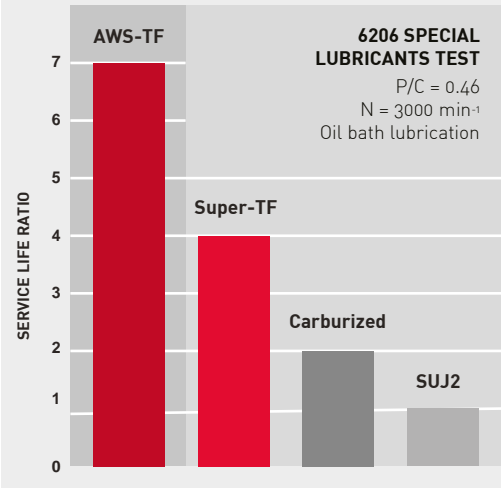

**AWS-TF delivers 7 times the life of standard steel (SUJ2), while STF delivers 4 times**

## ADHESIVE WEAR



**Location:**  
Main Shaft - 3 point suspension  
Planetary Carrier, Planet Gear

**Solution:**  
Super-TF (STF) Long-life Steel  
Black oxide coating

# EXAMPLES: BEARING NOMENCLATURE

## SPHERICAL ROLLER BEARING - 3 PT SUSPENSION

S W - 240 /600 - 01

- S Super-TF long-life steel
- W special process control for wind turbines
- 240 spherical roller bearing, width series 4, diameter series 0
- /600 bore diameter equals 600 mm
- 01 high capacity internal design



## CYLINDRICAL ROLLER BEARING - MODULAR DRIVETRAIN

S W - NJ 28 /710 - 01

- S Super-TF long-life steel
- W special process control for wind turbines
- NJ single row cylindrical roller bearing - 2 outer ring ribs, one inner ring rib
- 28 dimension series (width series 2, diameter series 8)
- /710 bore diameter equals 710 mm
- 01 design number

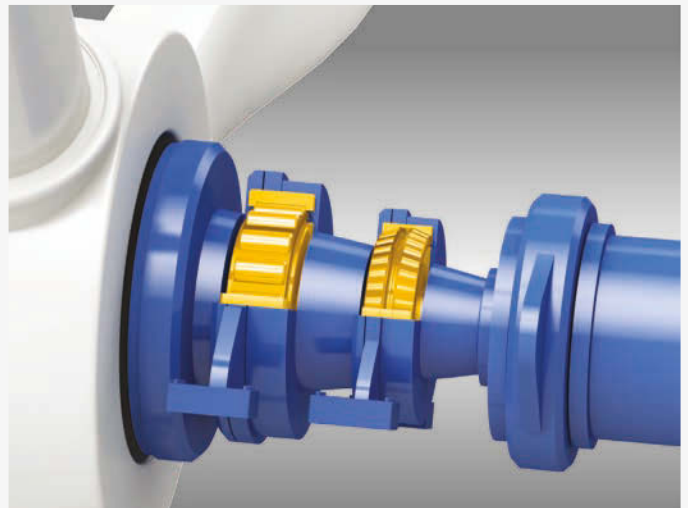

## TAPERED ROLLER BEARING, DOUBLE ROW - MODULAR DRIVETRAIN

S W - 460 KDH 65 01 - 01

- S Super-TF long-life steel
- W special process control for wind turbines
- 460 bore diameter equals 460 - 460.999 mm
- KDH double row tapered roller bearing, steep angle race
- 65 outer diameter equals 650 - 650.999 mm
- 01 tolerance for metric bearing
- 01 design number

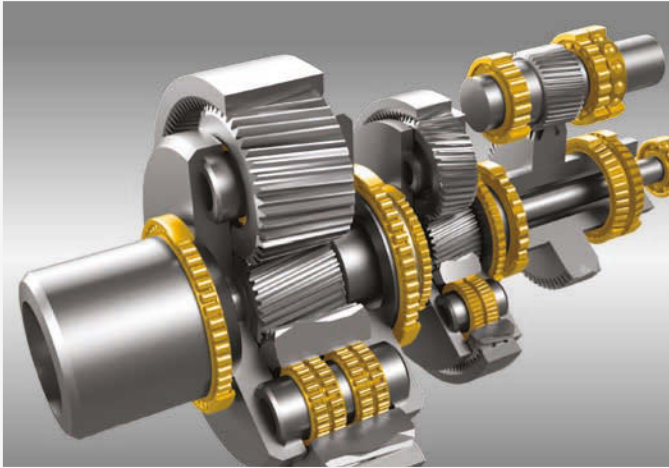

**CYLINDRICAL ROLLER BEARING, SINGLE ROW – HSIMS, HSS**

W | E | - | NU | 23 | 26 | - | 01

- W special process control for wind turbines
- E black oxide coating
- NU single row cylindrical roller bearing - 2 outer ring ribs, no inner ring ribs
- 23 dimension series (width series 2, diameter series 3)
- 26 bore diameter equals 130 mm (reference number x 5)
- 01 design number

**TAPERED ROLLER BEARING, DOUBLE ROW - LSS**

W | - | 431 | KH | 57 | 55 | - | 01

- W special process control for wind turbine bearings
- 431 bore diameter equals 431 - 431.999 mm
- KH double row tapered roller bearing
- 57 outer diameter equals 570 - 570.999 mm
- 55 tolerance for inch bearing
- 01 design number

**TAPERED ROLLER BEARING, SINGLE ROW - CARRIER SUPPORT**

W | E | - | R | 431Z | -3 | - | 01

- W special process control for wind turbines
- E black oxide coating
- R single row tapered roller bearing, special dimensions
- 431Z bore diameter equals 431 - 431.999 mm
- 3 serial number
- 01 design number

**TAPERED ROLLER BEARING, DUPLEX - HSIMS, HSS, LSIMS**

A | W | - | 303 | 26 | / | 313 | 26 | - | 01

- A AWS-TF long-life steel, specially developed to prevent white etching cracks
- W special process control for wind turbines
- 303 303: medium width series 0, diameter series 3
- 313 313: steep angle width series 1, diameter series 3
- 26 bore diameter equals 130 mm (reference number x 5)
- 01 design number



**CYLINDRICAL ROLLER BEARING, FULL COMPLEMENT - PLANETARY CARRIER AND GEAR**

W	E	-	NNCF	50	44	DR	-	01
---	---	---	------	----	----	----	---	----

**W** special process control for wind turbines  
**E** black oxide coating  
**NNCF** full complement cylindrical roller bearing, double row  
**50** dimension series (width series 5, diameter series 0)  
**44** bore diameter equals 220 mm (reference number x 5)  
**DR** controlled size variation arrangement  
**01** design number

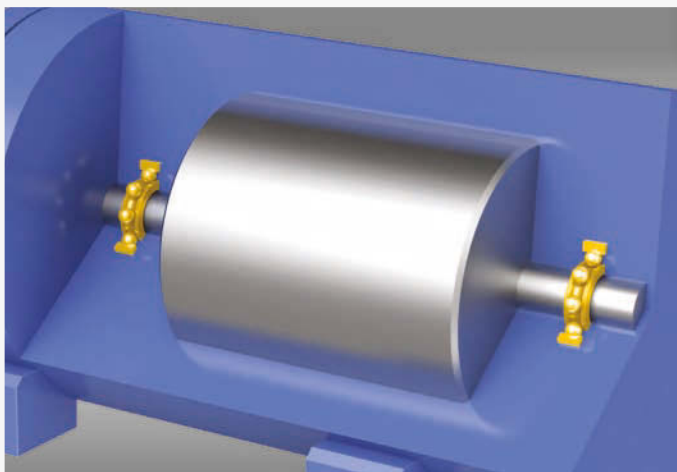

**FOUR POINT CONTACT BALL BEARING - HSIMS, HSS**

W	-	QJ	3	28	-	01
---	---	----	---	----	---	----

**W** special process control for wind turbine bearings  
**QJ** four point contact ball bearing  
**3** dimension series 3  
**28** bore diameter equals 140 mm (reference number x 5)  
**01** design number

**DEEP GROOVE BALL BEARING, CERAMIC COATED - GENERATOR**

W	C	-	63	30	-	01
---	---	---	----	----	---	----

**W** special process control for wind turbines  
**C** ceramic coated outer ring  
**63** deep groove ball bearing, diameter series 3  
**30** bore diameter equals 150 mm (reference number x 5)  
**01** design number

**DEEP GROOVE BALL BEARING - CONDUIT TUBE**

60	26	DDU	C3	&	AS2S
----	----	-----	----	---	------

**60** single row deep groove ball bearing dimension series 0  
**26** bore diameter equals 130 mm (reference number x 5)  
**DDU** contact seals (non-contact seals and shielded closures available)  
**C3** greater than normal radial internal clearance  
**&** NSKHPS symbol - High Performance Standard  
**AS2S** grease type and fill





## NSK AMERICAS

**Argentina**  
NSK Argentina SRL  
Buenos Aires  
54.11.4762.6556

**Brazil**  
NSK Brasil Ltda.  
Sao Paulo SP  
55.11.3269.4700

**Canada**  
NSK Canada Inc.  
Mississauga ON  
1.877.994.6675

**Latin America**  
NSK Latin America Inc.  
Miami FL  
1.305.477.0605

**Mexico**  
NSK Rodamientos Mexicana,  
S.A. de C.V.  
Tlaineantla de Baz MX  
52.55.3682.2900

**United States**  
NSK Corporation  
Ann Arbor MI  
1.888.446.5675

**Website:** [www.nskamericas.com](http://www.nskamericas.com)  
**NSK Global:** [www.nsk.com](http://www.nsk.com)

Every care has been taken to ensure the accuracy of the data contained in this brochure, but no liability can be accepted for any loss or damage suffered through errors or omissions.

Printed in the USA ©NSK 2018.  
The contents of this publication are the copyright of the publishers.