

SUPER PRECISION BEARINGS





INTRODUCTION

As technologies evolve, all manufacturers share a global responsibility to respect and protect the environment. NSK Motion and Control products reflect our corporate commitment to environmental responsibility. While our products improve the performance of machines in a variety of industries, they also save energy and conserve resources because of our superior precision machining technologies.

To meet the needs of the highly specialized machine tool industry, we have enhanced each and every aspect of our R&D capabilities at our Technology Centers. Therefore, NSK's precision bearings are used in a wide variety of industries, such as semiconductor production and industrial robots, and have earned a reputation for excellent performance. Today, NSK manufactures highly accurate, reliable precision bearings in Japan and Europe and supplies them all over the world.

This catalog explains technical materials including our latest research and experimental data, various applications, the types of precision bearings available, and the proper utilization of each specific type of NSK's precision bearing.

MOTION & CONTROL™
NSK

Part1. NSK Super Precision Bearings

Global Support Capabilities	P6
Development Capabilities	P8
Quality Control and Production Capabilities	P10

Part2. Features of Precision Bearings

Metallurgical Technology to Extend Bearing Life	P14
Ceramic Balls	P16
Cages	P18
Product Range	P20
Performance of Each Bearing Type	P22

Part3. Guidelines for Bearing Selection

Selection Flow	P36
Typical High-Speed Spindle Structures	P38
Other Spindle Structures	P40
Features of Angular Contact Ball Bearings	P44
Features of Cylindrical Roller Bearings	P46

Part4. Bearing Types

1. Angular Contact Ball Bearings	
Angular Contact Ball Bearings	P50-107
Numbering System	
Bearing Tables	
High Accuracy Angular Contact Ball Bearings (Standard Series)	
Ultra High Speed Angular Contact Ball Bearings (NSKROBUST Series)	
2. Cylindrical Roller Bearings	
Cylindrical Roller Bearings	P110-127
Features	
Numbering System	
Bearing Tables	
Single Row Cylindrical Roller Bearings (Standard Series)	
Ultra High Speed Single Row Cylindrical Roller Bearings (NSKROBUST Series)	
Double Row Cylindrical Roller Bearings	
3. Angular Contact Thrust Ball Bearings	
Angular Contact Thrust Ball Bearings	P130-141
Features	
Numbering System	
Bearing Tables	
High Speed Angular Contact Thrust Ball Bearings (NSKROBUST Series)	
Angular Contact Thrust Ball Bearings (NSKTAC F Series)	
Double Direction Angular Contact Thrust Ball Bearings (NSKTAC D Series)	

4. Ball Screw Support Bearings

NSKHPS Angular Contact Thrust Ball Bearings for Ball Screw Support	P144-149
Features	
Numbering System	
Bearing Tables	
For High Rigidity Applications (NSKTAC C Series)	
For High-Load Drive Applications (NSKTAC O3 Series)	
NSKHPS Angular Contact Thrust Ball Bearings for Ball Screw Support (Double-Row)	P150-153

Features	
Numbering System	
Bearing Tables	
Double-Row bearings (BSBD Series)	
Units for Ball Screw Support	P154-155
Features	
Numbering System	
Support Unit Tables	

5. Tapered Roller Bearings

Tapered Roller Bearings	P158-161
Features	
Numbering System	
Bearing Tables	

6. Thrust Bearings

Thrust Bearings	P164-173
Features	
Numbering System	
Bearing Tables	
Single Direction Thrust Ball Bearings	
Thrust Cylindrical Roller Bearings	
Thrust Cylindrical Roller Bearings for Vertical Lathe Table	

ROBUSTSLIM	P174-175
Features	
Numbering System	
Bearing Tables	
High Accuracy Low Profile Angular Contact Ball Bearings (ROBUSTSLIM Series)	

7. Peripheral Equipment

Gauges	P178-181
GR Gauges	
Features	
Gauge Dimensions	
GN Gauges	
Features	
Gauge Dimensions	
NSK Bearing Induction Heater	P182-183
Grease Replenishing System FINE-LUB II	P184-185
High Speed Built-in Motor Spindle	P186-187

Part5. Technical Guide

1. Life	P190-197
· Rolling Fatigue Life and Dynamic Load Rating	
· New Life Theory	
· Features of Micro-UT™	
2. Basic Static Load Ratings and Static Equivalent Loads	P198-199
3. Angular Contact Ball Bearing Combinations	P200-205
· Features of Each Combination	
· Precautions for Handling of Bearing Sets	
· Universal Arrangement	
4. Preload and Rigidity	P206-215
5. Limiting Speeds	P216-217
6. Lubrication	P218-221
7. Bearing Tolerances	P222-231
· Tolerances for Radial Bearings	
· Tolerances for Tapered Bores	
· Tolerances for Angular Contact Thrust Ball Bearings	
· Tolerances for Tapered Roller Bearings	
· Tolerances for Thrust Ball Bearings	
8. Designing of Shafts and Housings	P232-236
· Fitting of Shafts and Housings	
· Shafts and Housing Tolerance	
· Chamfer Dimensions	
9. Spacers	P237-241
· Spacer Dimensions	
· Nozzle Position	

Part6. Bearing Handling

1. Mounting	P244-265
1. Cleaning the Bearings and Related Parts	
2. Checking Dimensions of Related Parts	
3. Mounting Procedures	
4. Inspection after Mounting	
2. Operational Inspection	P266-267
3. Running-in Method	P268-269

Part7. Bearing Failure Diagnosis

1. Examples of Bearing Failures and Countermeasures	P272-277
2. Diagnosis with Sound and Vibration	P278-279

Part8. Appendices

1. Tolerances for Shaft Diameters	P282-283
2. Tolerances for Housing Bore Diameters	P284-285
3. Values of Standard Tolerance Grades IT	P286-287
4. Conversion Table for SI Units	P288
5. Physical and Mechanical Properties of Material	P289-290
6. Bearing Inspection Request Form	P291
7. Bearing Specifications Request Form	P292

SUPER PRECISION BEARINGS

Part 1

Contents

Part1. NSK Super Precision Bearings

Global Support Capabilities ————— P6

Development Capabilities ————— P8

Quality Control and Production Capabilities ————— P10



Uniform support system all over the world

NSK is committed to manufacturing and selling products all over the world with a consistently high quality under the leadership of Technology Centers in the four major global markets. Staffed with experts that constantly endeavor to understand our customers' evolving needs NSK's sales offices promote global network management that encompasses our Technology Centers and production sites.

NSK is able to respond quickly and effectively to the various needs of customers and supports their business development efforts in any region.

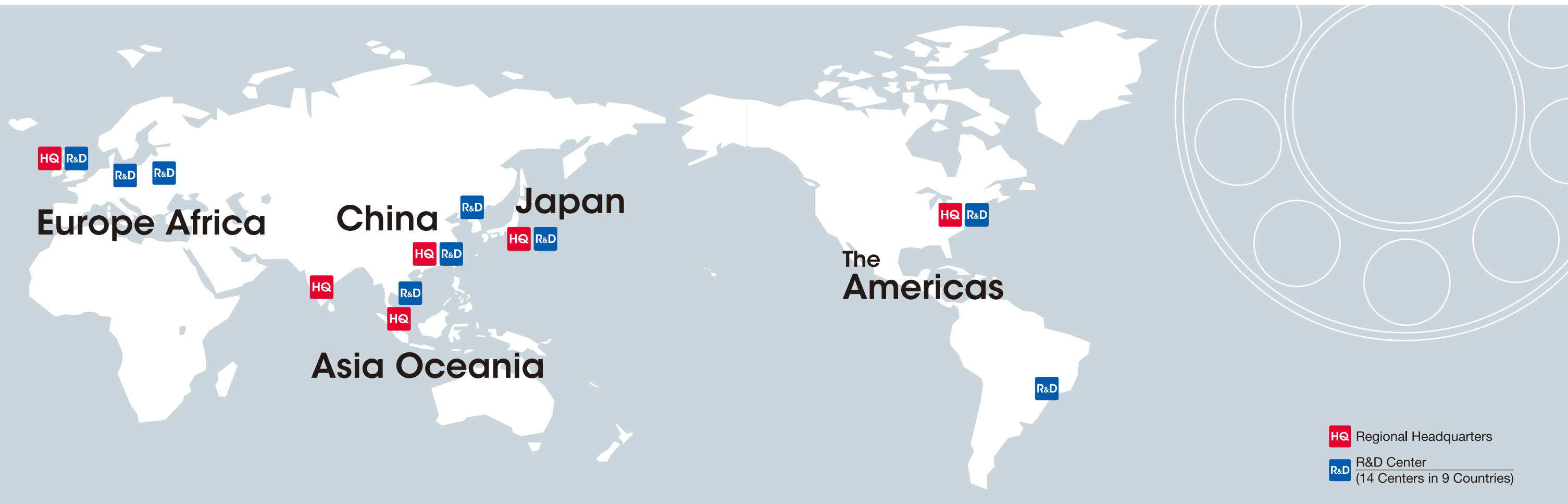

(as of March 31st, 2024)

01 Global network management provides optimal, high-quality products

NSK has established a highly developed information network centered on Technology Centers located in the four major markets of the world – Europe, the United States, Asia and Japan. With this network, we are able to gather information, in real time, related to the changes and trends in any market in the world. As a result, we are able to react quickly to meet changing customer needs to supply optimal, high-quality products.



Information system directly linked to customers

02 Technology Center customer support

Our 14 Technology Centers are located in 9 countries around the world; they offer technical support and provide the information that enables our customers to use NSK's products under ideal conditions and achieve the best possible performance.



03 Custom products for unique customer applications

Because of our superior development and machining capabilities, NSK's products deliver impressive performance in terms of both quality and cost. Our product supply system enables us to provide customized solutions for highly-specialized customer needs.

04 Our global support network is available wherever our customers are located

Our extensive global network is able to receive orders and supply products anywhere in the world. NSK's distributors cover the globe and maintain an inventory of all critical products in every major market and location, making it possible to supply products to customers without delay. NSK also provides technical support worldwide to help customers determine the best bearing for each application, respond quickly to any questions, and immediately address any problems our customers may encounter.



<http://www.nsk.com>

In the service of our customers and society

Since our forebears at NSK manufactured the first bearing in Japan in 1916, we have developed a wide range of bearing types. Building on the technological know-how we achieved, we have expanded into precision components and automotive parts. Thus NSK has been contributing to the evolution of industry, to making peoples' lives safer and easier, and to the conservation of global environment. NSK started overseas activities in the early 1960s and today encompasses a network of production plants, sales offices and Technology Centers across 31 countries; this enables us to respond quickly to customer requests and regional requirements anywhere in the world with specially designed and regionally manufactured products. NSK is working to further advance its Four Core Technologies in the service of customers and society, to forge ahead with the development of environmentally friendly products based on these technologies.

NSK's technological foundation

Four Core Technologies plus One

Tribology

Tribology is the study of friction and wear of contact surfaces in relative motion, such as rotating parts that endure enormous forces with a thin oil film. Severe operating conditions are mitigated through lubrication and surface treatments developed by NSK, resulting in superior performance for applications requiring low friction, high-speed rotation, quiet operation, or enhanced durability.

Areas Lubricant (oil, grease, additives), Friction Control, Creation of Functional Surfaces

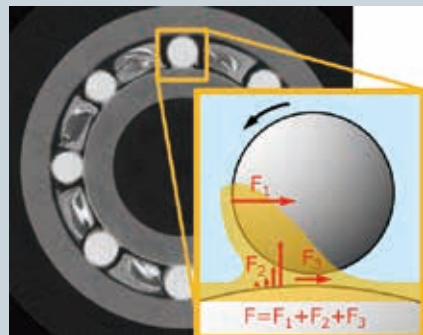

Friction on the bearing's ball surface

Numerical Simulation

In the past, accuracy and reliability in product development were achieved with experience-based design and longer testing periods. NSK's simulation technology allows virtual validation to accelerate design and production. Extreme conditions or innovative designs that defy previous expectations can also be evaluated and analyzed.

Areas Motion/Friction Analysis, Analysis of Macro-Scale and Nano-Scale Lubrication, Simulation



Simulated example of an automotive component

Materials

Materials research and development affects nearly every aspect of product performance. Through careful selection of material composition, heat treatment, and ceramic materials, NSK enables optimization of application performance. This may result from improvements in function, endurance, or reliability, or through advancements in cost-effectiveness or production efficiency.

Areas Sliding Materials (brass, resin, ceramic materials), Heat Treatment, Material Fatigue



Durability testing machines

Mechatronics

Mechatronics integrates machine elements technology with control technology. By combining bearings, ball screws and linear guides, together with motors, sensors and computers, greater mechanical functionality is elicited with computer control. This technology applies new functions and performance to a range of industrial machinery, such as for automobiles and bio-medicine. It also contributes to greater reliability, as well as to convenience and safety in daily life.

Areas Motors / Circuits / Control Technology, Sensors, Technology for Biomedical Micro electro mechanical Systems (Bio-MEMS)

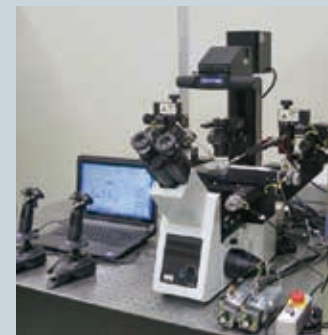

Manipulation system for bio-medicine

plus One Manufacturing Engineering

Contributing to the environment and heightening safety and security through our Four Core Technologies requires something to breathe life into these technologies. In addition, it is essential to consistently produce with high quality. NSK tackles these issues by applying AI to its equipment, utilizing IoT, and optimizing its overall production framework while it works to realize the creation of smart factories that economize on space, save on energy, and reduce manpower requirements.



Cheonan Plant in South Korea

Leadership in quality

NSK Super Precision Bearings deliver the highest level of accuracy, supported by our production lines featuring state-of-the-art equipment and our unique production technology, as well as our commitment to applying the same rigorous quality control procedures at each stage of the production process in every NSK facility.

At our global production sites in Japan and England we at NSK focus our efforts on offering highly accurate products to quickly meet the diverse needs of customers worldwide.

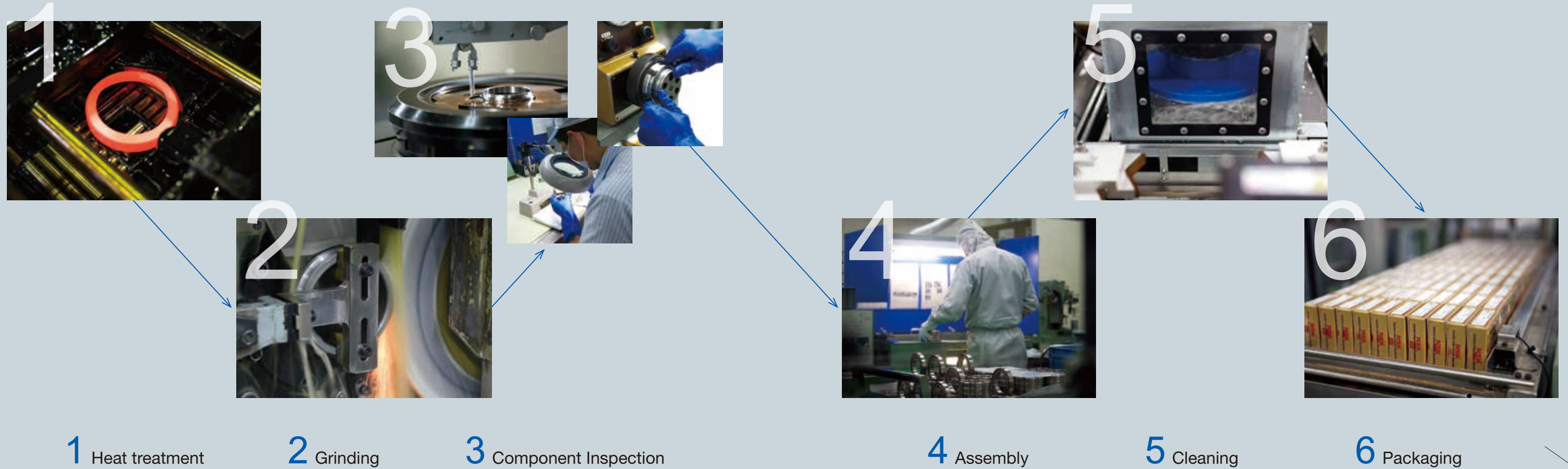

01 Manufacturing to highest accuracy

NSK Super Precision Bearings are checked to nanometer accuracy. Our extraordinary level of manufacturing technology enables us to supply products with the highest degree of accuracy in the world.



02 Global production sites in England and Japan

NSK Super Precision Bearings are made in both England and Japan. The combined expertise and locations of these manufacturing facilities enable us to quickly respond to customer requests.



NSK Newark Plant

NSK Fujisawa Plant

03 Complete quality control and environmental responsibility

As members of an ISO 9001-certified enterprise, all NSK plants adhere to strict international standards for quality control. NSK is also making an all-out, company wide effort to address environmental concerns as a top priority.



ISO 9001 Certification



ISO 14001 Certification

04 NSK symbol

NSK's golden box guarantees the highest level of accuracy.



High Performance in the Next Generation

NSK continually challenges the status quo to explore new possibilities. As our design philosophy does not allow us to compromise quality in manufacturing, we are driven to develop total solution technologies.

By using the latest material and analysis technologies we are able to design and manufacture exceptional, high performance precision bearings.

NSK will always strive to achieve the quality and performance that will be required in the next generation of bearings.

Contents

Part2. Features of Super Precision Bearings

- Metallurgical Technologies to Extend Bearing Life — P14
- Ceramic Balls — P16
- Cages — P18
- Product Range — P20
- Performance of Each Bearing Type — P22



Three specialized steels deliver the long life and high performance of NSK Super Precision Bearings

NSK uses groundbreaking technologies in steelmaking and the evaluation of non-metallic inclusions to extend life and enhance the performance of rolling bearings.

Our Super Precision Bearings feature three signature materials: Z Steel for extended life under normal conditions across applications, SHJ steel for high reliability under heavy loads or contaminated environments, and SHX Steel for ultra-high-speed rotation.

SUJ2 Z Steel: The Long-Life Standard for NSK Super Precision Bearings

SUJ2 Z Steel Standard Long Life Material Long Life Steel With Few Non-Metallic Inclusions

Typical bearing steels have impurities that significantly affect the rolling fatigue life of rolling bearings, with oxide inclusions having a particularly harmful effect. With fewer inclusions, Z Steel provides super precision bearings with longer life.

Features

In the typically clean environments where super precision bearings are used, subsurface-originated flaking is a chief cause for the end of bearing life. With Z Steel, NSK-exclusive technology is used to evaluate steel purity, minimize oxygen content, and reduce impurities such as titanium and sulfur, providing longer life.

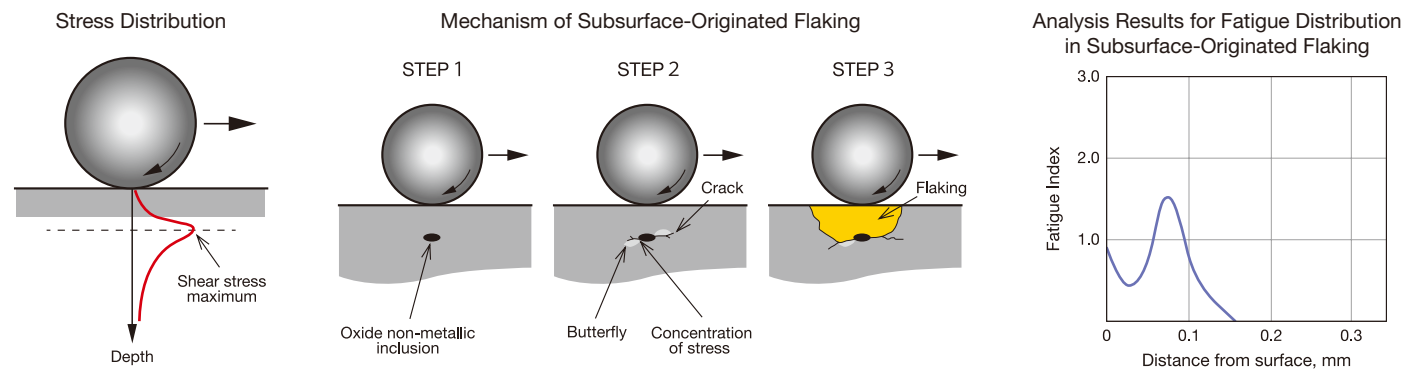

SHJ Steel 2x Fatigue Life of SUJ2 Z Steel

SHJ Steel combines NSK's exclusive cleanliness technology and optimized alloying to provide bearings with further extended life.

Features

With over 2x the life of SUJ2 Z Steel, SHJ Steel can be used under heavy loads and provides higher reliability in contaminated environments.

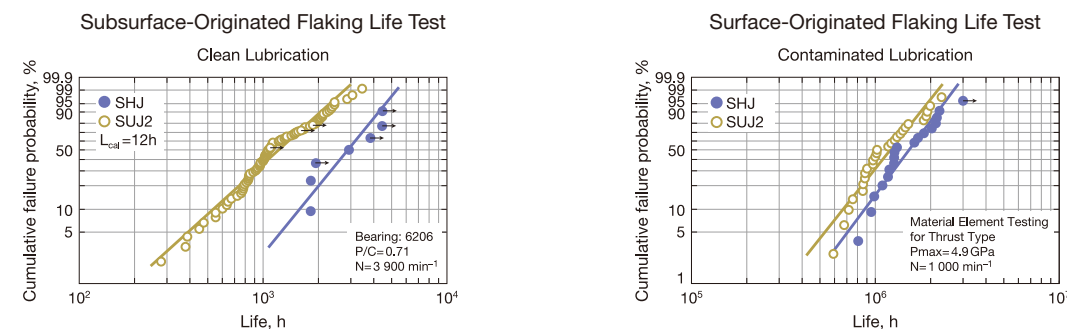

SHX Steel Endures Ultra-High-Speed Rotation Environments

SHX Steel Seizure Resistant SHX Steel for High Temperature and High Speed Applications 4 Times Longer Fatigue Life and 20% Higher Speed Than SUJ2 Z steel

SHX Steel offers reliable heat resistance thanks to NSK's unique heat treatment technology.

Features

Outperforming M50 Steel used for bearings on the main shaft of jet engines, SHX Steel offers superior wear resistance and rolling fatigue life. This patented steel expands applications for rolling bearings by delivering trusted performance.

Seizure Resistance

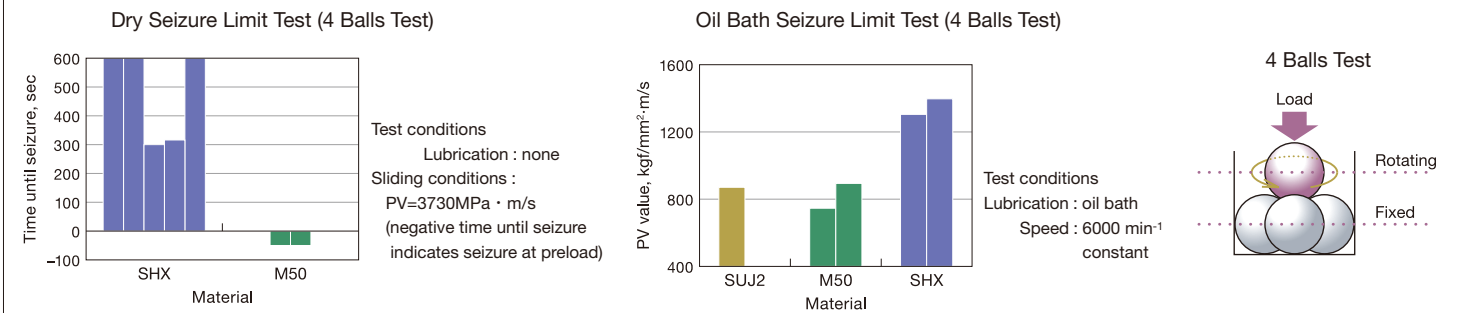

Wear Resistance

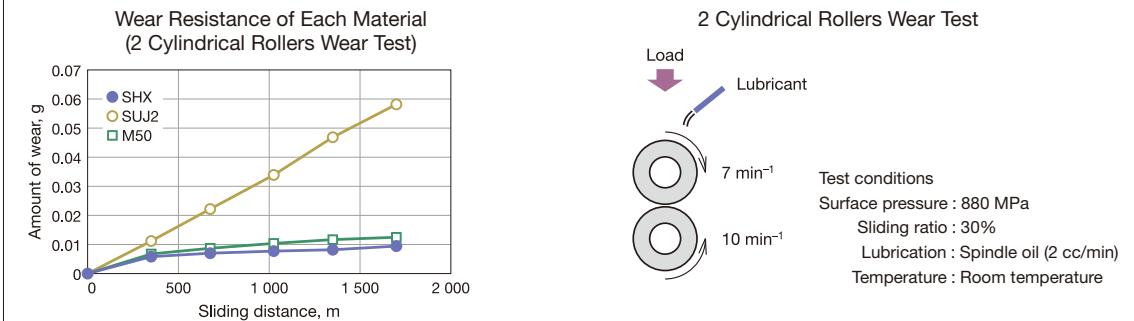

Fatigue Life

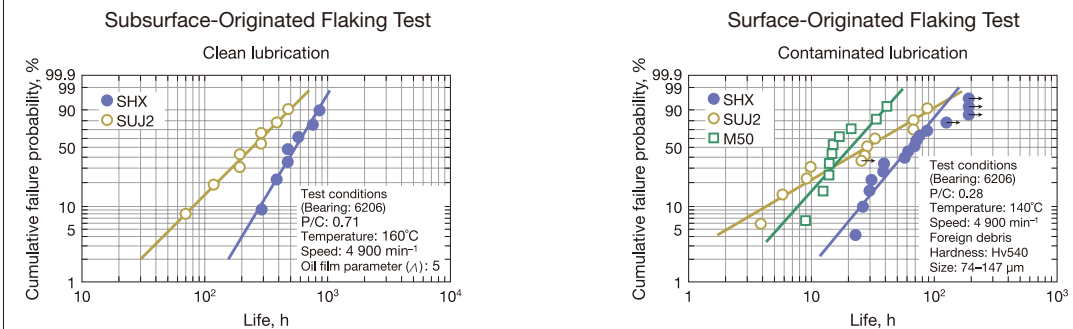

Products made of SHX Steel



High speed, low heat generation, high rigidity and high reliability

Ceramic ball bearings have many excellent performance characteristics such as heat resistance, durability, light weight, lower thermal expansion, electrically non-conductive and thus can be used in a nearly infinite number of applications as a new generation material. Applying our extensive experience in bearing manufacturing at NSK, we introduced silicon nitride (Si_3N_4), a ceramic with outstanding characteristics, to rolling elements. Ceramic ball bearings have earned a good reputation in ultra high speed applications combined with ultra high accuracy, a performance combination that cannot be achieved with steel ball bearings.



Low Heat Generation

- **Light weight**
As the weight is 60% lower than that of steel, the centrifugal force acting on the rolling elements is smaller, resulting in lower heat generation.
- **Low linear expansion coefficient**
Due to low thermal expansion, preload increase with position preload is minimized.
- **Low friction**
Low heat generation because of low sliding friction in high-speed applications.

Less heat is generated, making ultra high-speed operation possible

Calculated Results of Friction Loss

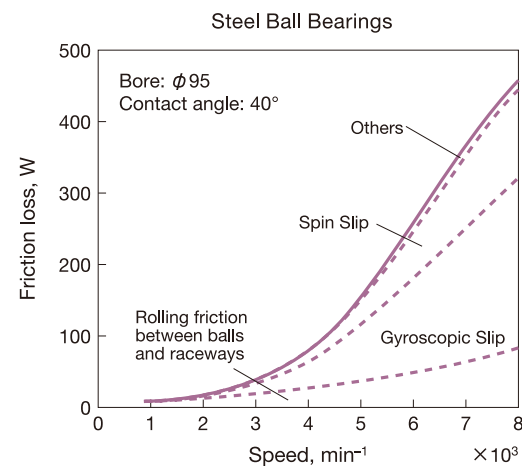
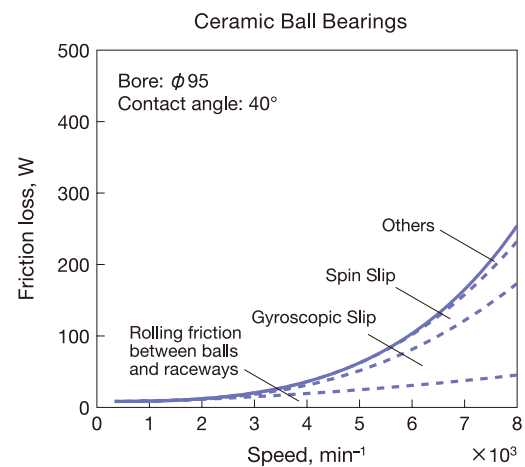

The Outer Ring Temperature Rise in High Speed Operation

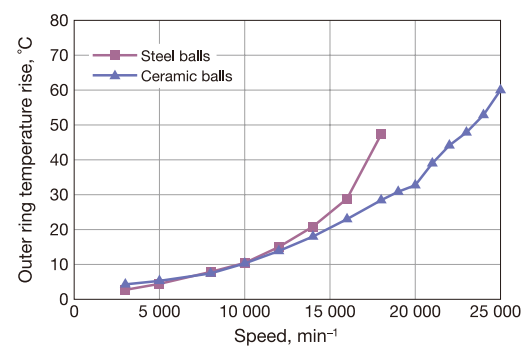

NSK Spindle that achieved 4 million d_{mn} using ceramic ball bearings

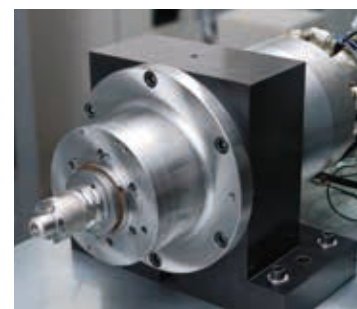

Ceramic Ball Bearing



Seizure Resistance

Ceramic balls exhibit a higher seizure resistance than steel balls

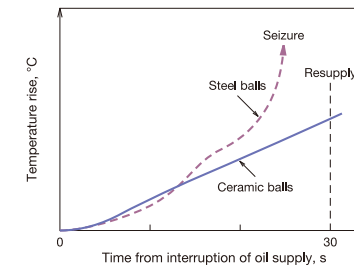

Cutting with NSK spindle using ceramic ball bearing



End Mill: $\phi 16$
Work Material: A5052
Speed: $20\,000\text{ min}^{-1}$
2 500 cc/min

High Rigidity

The Young's Modulus of ceramic balls is 50% higher than that of steel. This results in high rigidity bearings ideally suited for use in machine tool spindles.

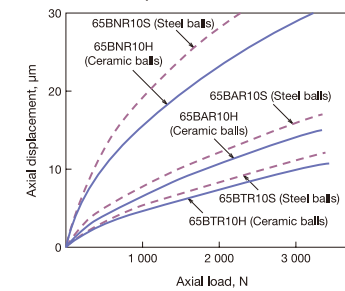

Cutting with NSK spindle using ceramic ball bearing



Face Mill: $\phi 80$
Work Material: C50
Speed: $1\,200\text{ min}^{-1}$
504 cc/min

High Accuracy

NSK's expertise in the manufacturing of balls over the years, along with improvements in the sintering process and the grade of materials used enables NSK to produce ceramic balls that feature a higher level of accuracy than steel materials. Bearings using these high-accuracy ceramic balls facilitate high-accuracy machining.

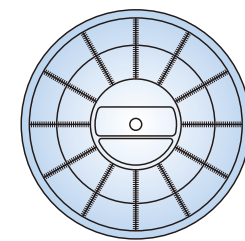

Size: 9/32"
Magnification: 50 000 times
Roundness of ceramic ball

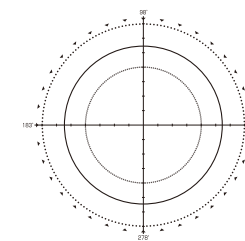

Roundness of material being ground: $0.14\ \mu\text{m}$
 $1\ \mu\text{m/div}$



High magnification (200 000 times)
Sphericity measuring equipment

Extended Grease Life

Low heat generation and seizure resistance result in extended bearing life with grease lubrication.

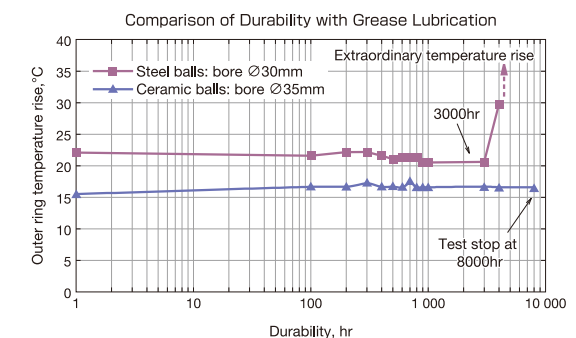
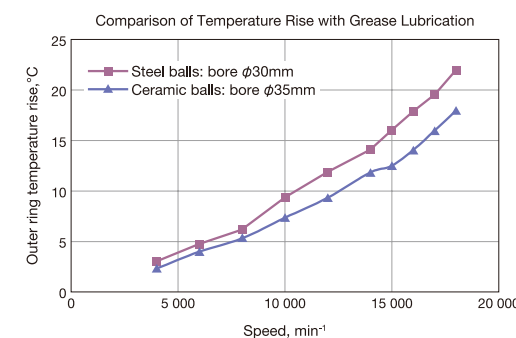

Preload: 147N (spring)
Grease used: ISOFLEX NBU15
Maximum speed: $n=18\,000\text{ min}^{-1}$

Engineered polymer cages offer higher speed capability and less wear

Engineered polymer cages are lighter (1/6 the weight of cages made of brass), self-lubricating and have a low friction coefficient. Bearings fitted with such cages generate less heat under high-speed rotation, making them excellently suited for high-speed operation. Polymers can be engineered for low wear, thus extending grease life. Engineered polymer cages are used in super precision bearings for machine tool spindles.

Cages for Angular Contact Ball Bearings

Ball Guided Polyamide Cage — (TYN) Engineered Polymer

Low Noise

- This special design developed by NSK produces lower friction and lower noise, especially with grease lubrication
- A ball-guided design means more space at the outer ring, allowing more grease to be held inside the bearing
- Grease running-in is shortened, with more stable temperature rise compared to outer ring guided phenolic cages

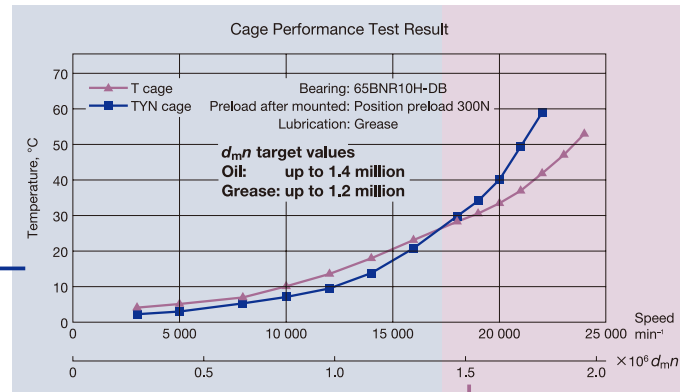

Products: High Accuracy Angular Contact Ball Bearings Standard Series
Ultra High Speed Angular Contact Ball Bearings NSKROBUST Series

Outer Ring Guided Phenolic Cage — (T, TR, TA)

Ultra High-Speed



· The outer ring guided cage offers excellent high-speed operation capability and exhibits stable temperature rise

Products:
High Accuracy Angular Contact Ball Bearings Standard Series
Ultra High Speed Angular Contact Ball Bearings NSKROBUST Series



Outer Ring Guided PPS SURSAVE™ Cage — (TSR) Super Engineering Plastic

Ultra High-Speed



- A high-performance cage that minimizes non-repeatable runout (NRRO) and offers low torque to realize low temperature rise
- Maintains grease lubrication in both sealed and open bearings
- Supports high speeds up to a $d_m n$ value of 3 000 000 under oil-air lubrication

Products:
Ultra High Speed Angular Contact Ball Bearings NSKROBUST Series



Ball Guided Brass Cage — (MY)

General Purpose



- This cage demonstrates high temperature resistance, high strength and high rigidity
- Specifically for large bearings

Products:
High Accuracy Angular Contact Ball Bearings Standard Series
Ultra High Speed Angular Contact Ball Bearings NSKROBUST Series



Cages for Cylindrical Roller Bearings

Cages for Single Row Cylindrical Roller Bearings

Outer Ring Guided PEEK Cage — (TP) Super Engineering Plastic

Ultra High-Speed

- Minimizes cage deformation to permit stable high-speed rotation
- Excellent wear-resistant performance, ideally for minimal lubrication



Products:
Ultra High Speed Single Row Cylindrical Roller Bearings
NSKROBUST Series



Roller Guided Brass Cage — (MR)

General Purpose

- This cage demonstrates high temperature resistance, high strength and high rigidity

Products:
Single Row Cylindrical Roller Bearings Standard Series

Cages for Double Row Cylindrical Roller Bearings

Roller Guided PPS Cage — (TB) Super Engineering Plastic

High Rigidity

- Optimal roller-guided cage design with consideration for strength and friction
- Light weight reduces deformation caused by centrifugal force at high speed, resulting in low temperature rise.



Products:
Double Row Cylindrical Roller Bearings
High Rigidity Series



Roller Guided Brass Cage — (MB)

General Purpose

- This cage demonstrates high temperature resistance, high strength and high rigidity



Products:
Double Row Cylindrical Roller Bearings
High Rigidity Series



NSKROBUST Series A high-performance lineup specialized for machine tools.

NSKHPS Series NSK's high-performance standard

Angular Contact Ball Bearings

	NSKHPS High Accuracy Angular Contact Ball Bearings (7xxx) NSKHPS
High-performance standard bearings with high dynamic load ratings optimal for applications with low to medium speed and high external loads.	
	BASIC Series Ultra-High-Speed Angular Contact Ball Bearings (BNR, BER) NSKROBUST
High-performance bearings developed for high-speed operation with low temperature rise. Suitable for ultra high-precision machining applications and ultra high-speed applications.	
	ROBUSTDYNA™ High Load Capacity/Ultra-High-Speed Angular Contact Ball Bearings (BNRD, BERD) NSKROBUST
High-performance bearings for applications involving heavy-duty cutting, the machining of tough materials, and high-speed rotation.	
	MINI Series Ultra-High-Speed Angular Contact Ball Bearings (BSR) NSKROBUST
High-performance bearings developed for high frequency spindles, small high-speed spindles and similar applications.	

Oil-Air Lubrication Support

	ROBUSTSHOT™ Outer Ring Oil Supply Bearings NSKROBUST
Compact, high-performance bearings for reliable oil-lubrication.	
	Spinshot™ II Inner Ring Oil Supply Bearings NSKROBUST
Quiet bearings that reduce the noise of oil-air lubrication.	

Angular Contact Thrust Ball Bearings

	BASIC Series High-Speed Angular Contact Thrust Ball Bearings (BAR, BTR) NSKROBUST
High-performance bearings developed for lathes and other applications requiring high speed and high axial rigidity.	

Cylindrical Roller Bearings

	BASIC Series Ultra-High-Speed Single Row Cylindrical Roller Bearings (N10xxRX, N10xxRS) NSKROBUST
High-performance bearings developed for high-speed applications such as machining center spindles.	
	NSKHPS High Accuracy High Performance Cylindrical Roller Bearings APTSURF NSKHPS
An optimized internal design and advanced manufacturing technologies extend the life of these high-performance standard bearings by 60% over conventional bearings. APTSURF bearings provide additional low vibration functionality in P4 Class accuracy and higher.	
Single-Row Cylindrical Roller Bearings (N10xx) Double-Row Cylindrical Roller Bearings (NN30xx)	

Angular Contact Thrust Ball Bearings for Ball Screw Support

	NSKHPS Angular Contact Thrust Ball Bearings for Ball Screw Support (xxTACxxC) NSKHPS
High-rigidity thrust bearings designed specifically for ball screw support applications in machine tools.	
	NSKHPS Angular Contact Thrust Ball Bearings for Ball Screw Support (xxTAC03D, TACxx-3) NSKHPS
Thrust bearings optimal for injection molding machines and electric press machines. An optimized internal design provides higher axial load carrying capacity and longer life.	

Thrust Bearings

	ROBUSTSLIM™ High-Accuracy Low-Profile Angular Contact Ball Bearings (BRSA) NSKROBUST
Specially designed angular contact ball bearings for swiveling (rotary/tilt) spindle heads and rotary/tilt tables used in machine tools.	

Grease

	ROBUSTGRD™ High-Performance Grease for Machine Tool Spindles NSKROBUST
Grease for high-speed rotation with excellent seizure resistance and improved reliability against coolant intrusion.	

Ultra-High-Speed Angular Contact Ball Bearings NSKROBUST Series

High performance angular contact ball bearings delivering high speed and low heat generation

Benefits

- 1 Low Heat Generation
- 2 Higher Seizure Resistance
- 3 Improved Thermal Robustness
- 4 Stable Rotation at High Speeds

High performance

ROBUSTDYNA X Type

High load capacity, high-speed, and long life with no compromises to performance

- Material of inner/outer rings: SHX Steel for high temperature and high-speed applications
- Large-diameter ceramic balls



Spinshot™ II XE Type

Quiet bearings that reduce the noise of oil-air lubrication

- Material of inner/outer rings: heat resistant SHX steel for high-speed operation
- Ceramic balls

ROBUSTSHOT

High performance bearings combining highly reliable oil-air lubrication and space-saving design

- Material of inner/outer rings: SUJ2 bearing steel
- Ceramic balls



BASIC Series X Type

High performance bearings delivering excellent wear and seizure resistance during ultra high-speed operation

- Material of inner/outer rings: heat resistant SHX Steel for high-speed operation
- Ceramic balls

ROBUSTDYNA J Type

High-performance bearings for high loads and high speeds

- Material of inner/outer rings: Long life SHJ Steel
- Large-diameter ceramic balls



BASIC Series H Type

High performance bearings that combine high-speed operation with low heat generation

- Material of inner/outer rings: SUJ2 bearing steel
- Ceramic balls



BASIC Series E Type

Steel ball bearing with improved seizure resistance and extended life

- Material of inner/outer rings: SUJ2 bearing steel
- Ultra long life bearings rolling elements



BASIC Series S Type

- Material of inner/outer rings: SUJ2 bearing steel
- Steel balls

Oil Air Lubrication Supply Method

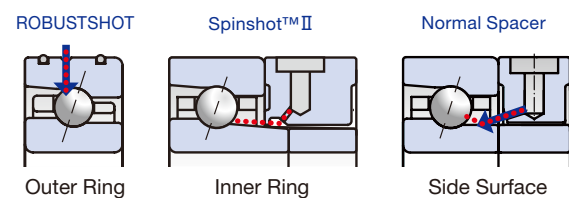

High speed

Features of Outer Ring Guided PPS SURSAVE™ Cage

Low Vibration and Low Torque

A high-performance cage that minimizes non-repeatable runout (NRRO) and offers low torque to realize low temperature rise.

High-Speed Performance

Maintains grease lubrication in both sealed and open bearings.

Durability

Supports high speeds up to a $d_m n$ value of 3 000 000 under oil-air lubrication.

Appearance of SURSAVE Cage

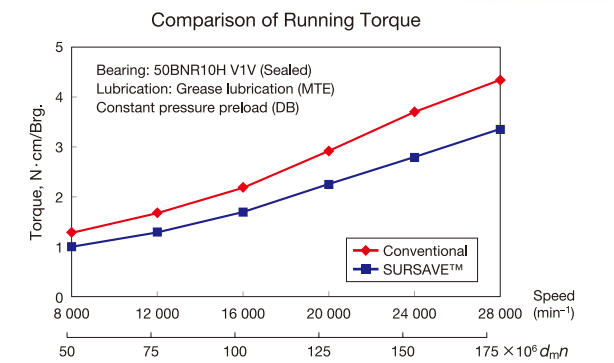
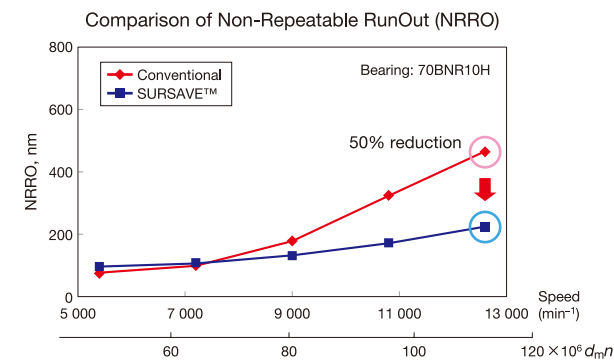

Features of BASIC Series E Type

Higher seizure resistance and extended life due to strengthened material.

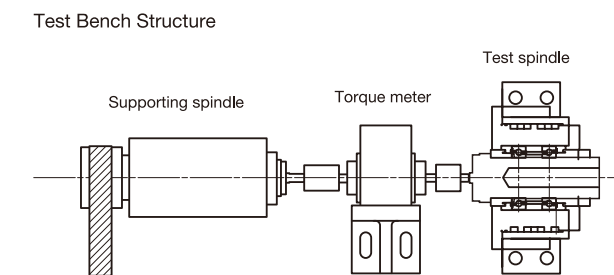
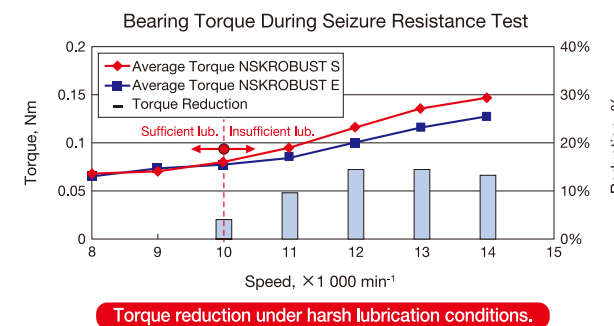

Features of BASIC Series Sealed Type

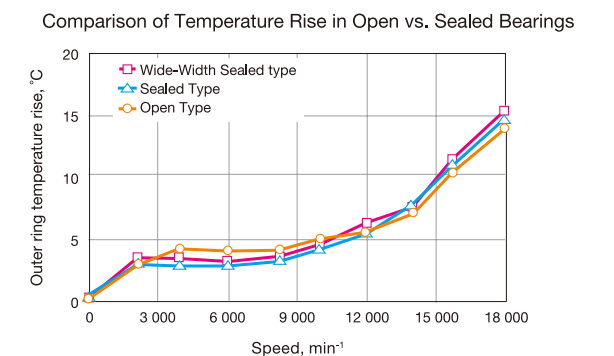
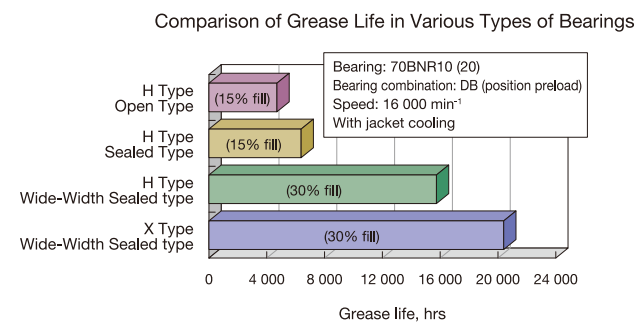

ROBUSTDYNA™ High Load Capacity/ Ultra-High-Speed Angular Contact Ball Bearings

With an optimized internal design and advanced material technology, ROBUSTDYNA angular contact ball bearings handle higher loads and offer longer life without compromising on speed.

Benefits

- 1 Improved Load Capacity
- 2 Longer Life
- 3 Higher Dent Resistance
- 4 Support for High Speeds



Optimized internal design

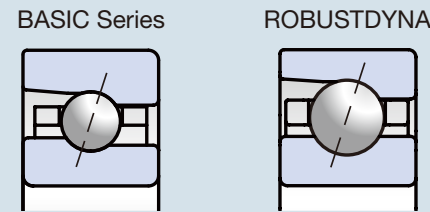

Advanced NSK ring materials

- ROBUSTDYNA X Type: High-speed heat-resistant SHX Steel
- ROBUSTDYNA J Type: Long-life SHJ Steel

Large diameter ceramic balls

Features of ROBUSTDYNA™

① High Load Capacity

Improved load capacity compared to our signature BASIC Series.

Permissible Radial Load During Machining

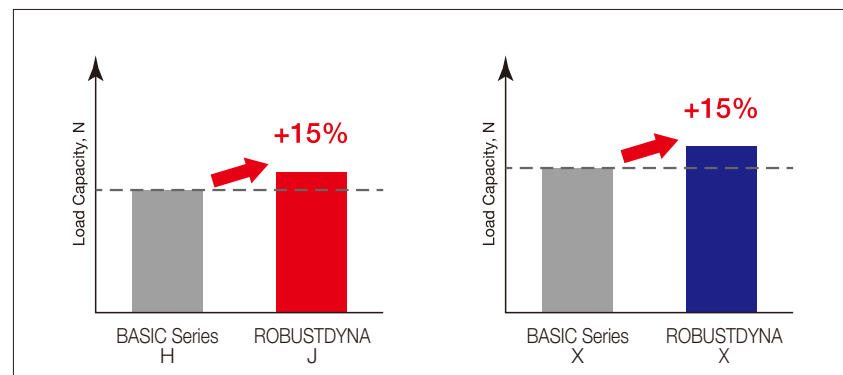

- Bore: $\phi 70$
- Contact angle: 18°
- Arrangement: DB (position preload)

② Long Life

ROBUSTDYNA bearings support higher dynamic loads and offer extended life.

The J Type uses SHJ Steel for unmatched life, while the X Type features SHX steel for heat resistance at high speeds.

Bearing Rolling Fatigue Life

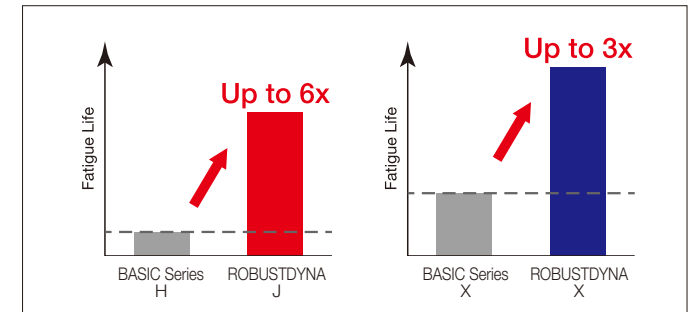

③ High impact resistance

With higher static load ratings, ROBUSTDYNA bearings reduce damage risks.

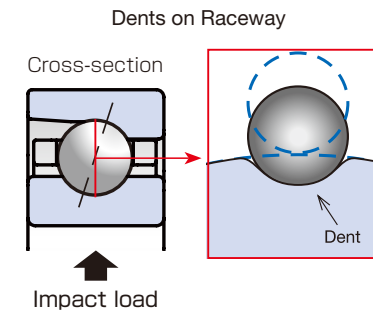

Result of Indentation Test

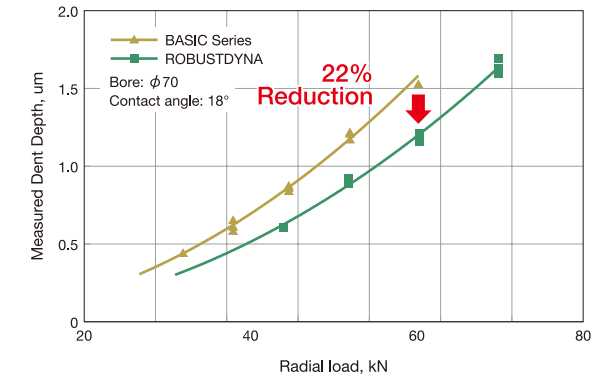

Impact Resistance Comparison

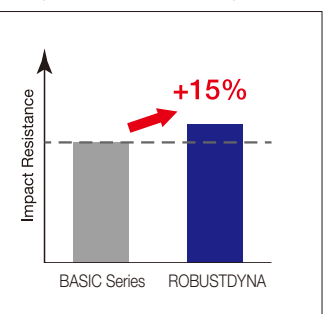

④ Ultra-High Speeds

With support for the same speeds as the BASIC Series, ROBUSTDYNA X bearings realize high-speed oil-air lubrication up to a $d_m n$ value of 3 million.

Results of Speed Evaluation Test

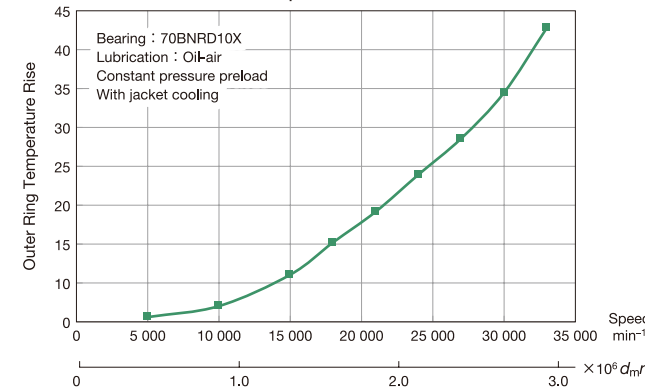

Speed Comparison

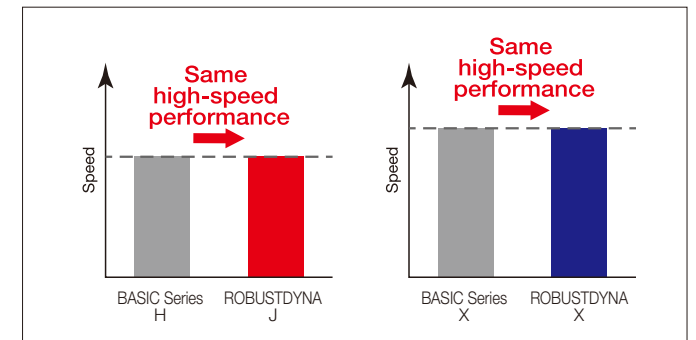

※ Note that BASIC Series bearings tend to have lower heat generation.

High-Speed Angular Contact Thrust Ball Bearings

High-performance bearings that combine high-speed capability with high rigidity

Benefits

- 1 High Rigidity
- 2 Low Heat Generation



High-Speed Angular Contact Thrust Ball Bearings BTR10 Series
40° contact angle, combining high rigidity and low heat generation.



High-Speed Angular Contact Thrust Ball Bearings BAR10 Series
30° contact angle delivers higher speed capability.



Angular Contact Thrust Ball Bearings NSKTAC F Series
50° contact angle with higher axial rigidity.



Double-Direction Angular Contact Thrust Ball Bearings NSKTAC D Series
60° contact angle with the highest axial rigidity. Separable type.

MINI Series Ultra-High-Speed Small Angular Contact Ball Bearings

Combining low heat generation and high rigidity, for use with ultra-high-speed spindles

Benefits

- 1 Optimal for Constant-Pressure Preload
- 2 Easy to Handle With Non-Separable Structure
- 3 Available With Seals



Features of Angular Contact Thrust Ball Bearings for Lathe Spindles

Interchangeability between NSKTAC ⇔ BAR, BTR

BAR and BTR have special width dimensions. By replacing NSKTAC with BAR or BTR, it is possible to achieve lower heat generation and higher speeds. Correspondingly, replacing BAR or BTR with NSKTAC will provide higher rigidity (see figure on the right).

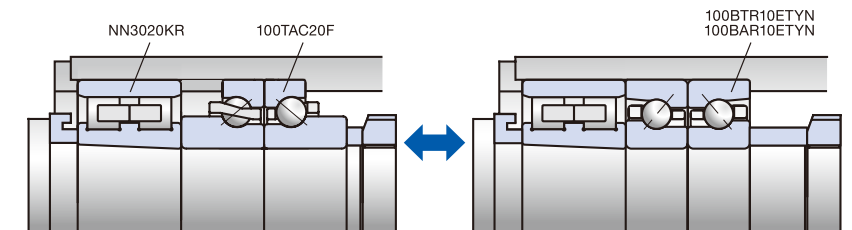

Limiting Speeds with Grease Lubrication (when lightly preloaded)

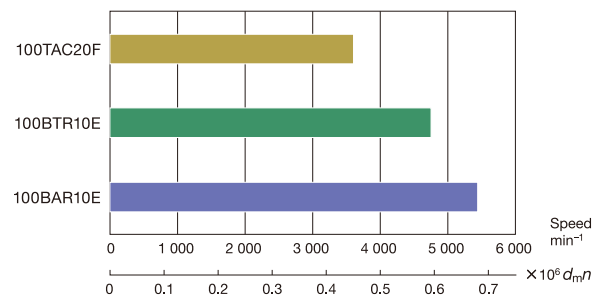

Axial Load and Axial Displacement

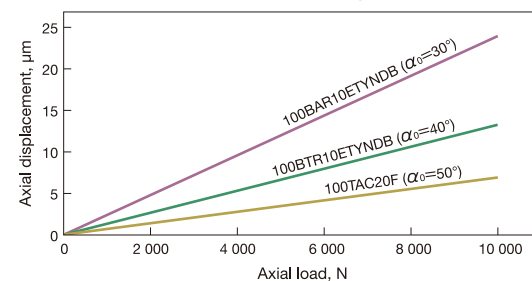

Features of MINI Series (BSR) Ultra-High-Speed Small Angular Contact Ball Bearings

Optimal Design

Rigidity remains high even during high-speed operation with constant pressure preload, minimizing the need to reduce maximum spindle speeds. A counter bore in the inner ring enlarges the opening for lubricant provided oil-air or oil mist lubrication to enter into the bearing, thus ensuring a stable oil supply.

Extended Life

X Type bearings feature our specialized SHX Steel for unmatched seizure resistance.

Easy Handling

Non-separable structure makes handling easy.

Low Maintenance

Available as sealed bearings to reduce maintenance.

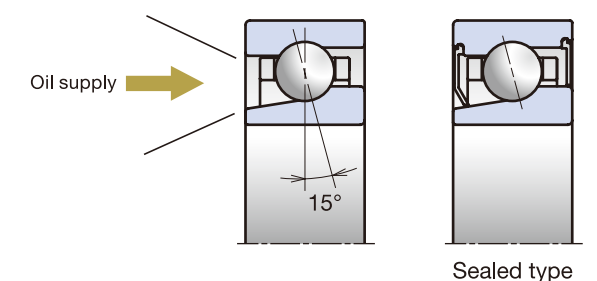
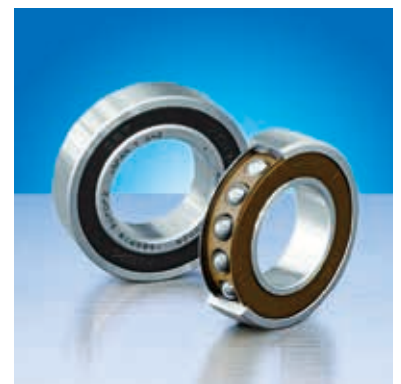

High-Performance Cylindrical Roller Bearings

Designed to achieve high-speed performance combined with high rigidity

Benefits

- 1 Low Heat Generation
- 2 Higher Seizure Resistance
- 3 Stable Rotation at High Speeds
- 4 Lower Vibration

High performance

NSKROBUST



**Ultra-High-Speed Single-Row Cylindrical Roller Bearings
BASIC Series RX Type**
High performance bearings with excellent heat and wear resistance during ultra-high-speed operation

- Material of inner/outer rings and rollers: SHX Steel for high speed and heat resistance
- Outer Ring Guided PEEK Cage



**Ultra-High-Speed Single-Row Cylindrical Roller Bearings
BASIC Series RS Type**
High speed bearings with excellent cost performance

- Material of inner/outer rings and rollers: SUJ2 bearing steel
- Outer Ring Guided PEEK Cage



**Double-Row Cylindrical Roller Bearings
High Rigidity MB Series**

- Material of inner/outer rings and rollers: SUJ2 bearing steel
- Roller Guided Brass Cage



**Double-Row Cylindrical Roller Bearings
High Rigidity TB Series**
High-performance bearings with polymer cages

- Material of inner/outer rings and rollers: SUJ2 bearing steel
- Roller Guided PPS Cage



**High-Performance Double-Row Cylindrical Roller Bearings
Low Heat Generation NN-Z Series**
Low heat generation free-end bearings

- Material of inner/outer rings and rollers: SUJ2 bearing steel
- Roller Guided PPS Cage



**Single Row Cylindrical Roller Bearings
Standard Series**
Standard bearings with brass cages

- Material of inner/outer rings and rollers: SUJ2 bearing steel
- Roller Guided Brass Cage

Long Life and Low Vibration

APTSURF

Long Life

NSKHPS

High speed

Features of APTSURF High-Accuracy High Performance Cylindrical Roller Bearings

- **Low Vibration (APTSURF)**
With higher accuracy components, APTSURF bearings reduce vibration during operation. Available for bearings with an accuracy rating of P4 or higher and an outside diameter of up to 360 mm.
- **Extended Life (NSKHPS)**
NSKHPS bearings use optimized internal designs and specialized manufacturing technologies to deliver a bearing life 60% longer than conventional bearings. Available for bearings with an accuracy rating of P5 or higher and an outside diameter of up to 360 mm.

Features of Double-Row Cylindrical Roller Bearings High Rigidity Series

- **Extended Life**
A high rigidity PPS (engineered polymer) cage demonstrates excellent wear resistance, resulting in lower wear during initial operation and longer grease life.
- **Available for High-Speed Applications**
NSK offers the Low Heat Generation NN-Z series for free-end bearings.

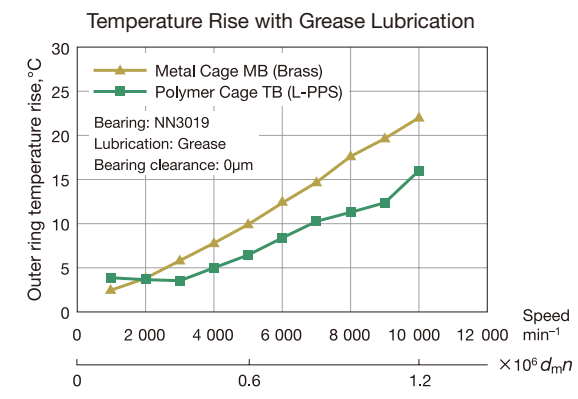

Features of NSKROBUST Series Ultra-High-Speed Single-Row Cylindrical Roller Bearings

- **Low Heat Generation**
A specialized internal design and advanced cage material result in low heat generation.
- **Seizure Resistance**
The RX Type features heat-resistant SHX steel for improved seizure resistance.
- **High-Speed Capability**
All types feature cages made of heat resistant and highly rigid PEEK material for high-speed operation.

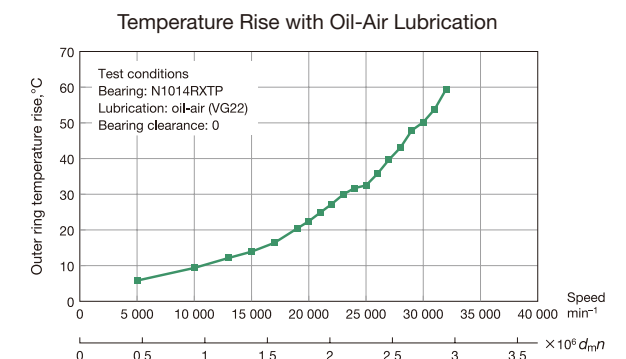
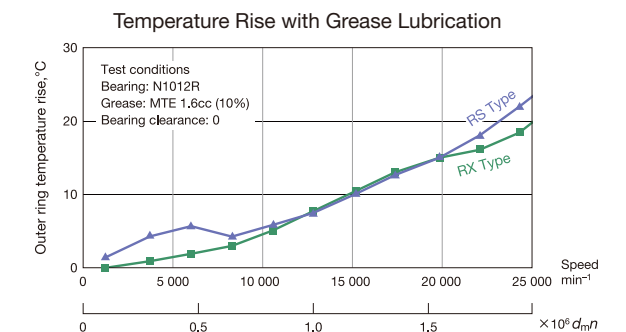
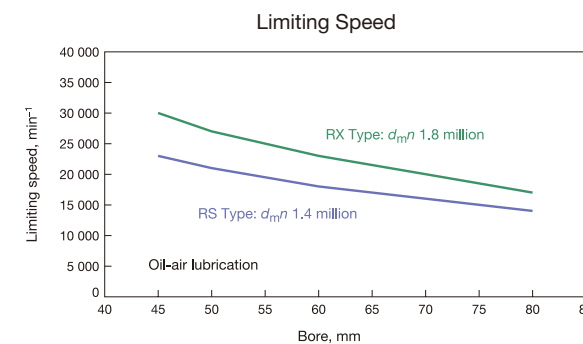

Angular Contact Thrust Ball Bearings for Ball Screw Support (High Rigidity)

Specialized high performance bearings with high rigidity—NSKTAC C Series



Benefits

- 1 Long Life
- 2 Low Torque
- 3 Easier Handling
- 4 High Accuracy

Features of NSKHPS NSKTAC C Series

Applications: ball screw support in machine tool feed drives, transport ball screws etc.

· Designed for High Performance in the Above Applications

60° contact angle and more balls ensure high rigidity.

· Contact Seal for High Reliability and High Dust Resistance as Standard

Bearings from this series are fitted with contact seals as standard; this achieves high dust-resistance prevents grease leakage.

Light seal contact for low torque and low heat generation.

Seal color is different on front and back face, for easy identification of bearing direction.

Non-contact seal is available for some bearings from this series.

· You choose the bearing arrangement

Universal arrangement is standard for this series, allowing free choice of arrangement in 2, 3 or 4 rows.

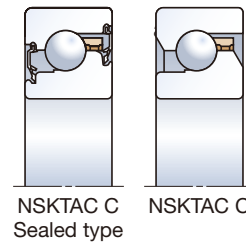

NSKTAC C
Sealed type

NSKTAC C

Angular Contact Thrust Ball Bearings for Ball Screw Support (Double Row)

Specialized high performance bearings with single outer ring and mounting holes—BSBD Series



Benefits

- 1 Easier Handling
- 2 Higher Reliability
- 3 Simplified Mounting Process

Features of NSKHPS BSBD Series

· Easier Handling

Double row angular contact thrust ball bearings in back-to-back arrangement(DB) with a single outer ring. The bearings from this series are contact sealed and pre-greased for easy handling.

· Higher Reliability

Fitted with a contact seal with minimized effect on frictional loss and heat generation.

· Simplified Mounting Process (BSF Type)

BSF Type bearings feature mounting holes for mounting directly onto the housing. The outer ring is equipped with an extraction groove for easier removal from the housing.

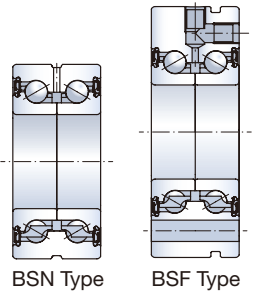

BSN Type

BSF Type

Angular Contact Thrust Ball Bearings for Ball Screw Support (for High-Load Drive Applications)

Specialized high performance bearings simplify machine design and reduce costs—NSKTAC 03 Series



Benefits

- 1 Long Life
- 2 Higher Axial Load Maximum
- 3 Easier Handling

Features of NSKHPS NSKTAC 03 Series

· Longer Bearing Life

Larger size balls and a 55° contact angle for extended bearing life.

· Higher Axial Load Maximum

Optimized internal design of the bearings yields higher axial load capacity.

· Special Bore Series for Higher Load Capacity with Unchanged Shaft Diameter

The Special Bore Series are Standard Series bearings of the next larger size with only their bore reduced in size, permitting higher load capacity with the same shaft diameter as well as more compact screw shaft ends.

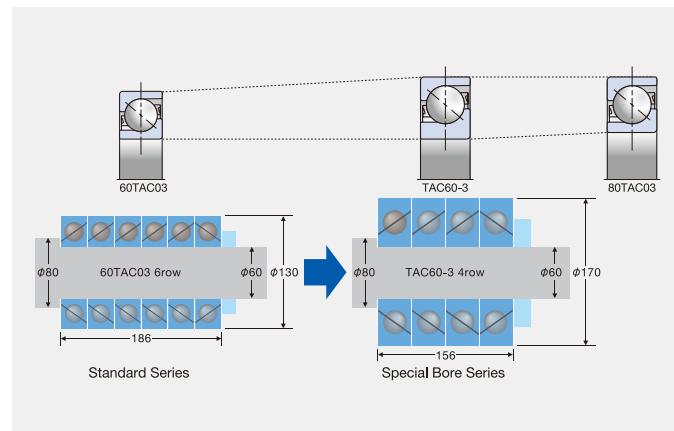

60TAC03
60TAC03 6row
186
Standard Series

TAC60-3
TAC60-3 4row
156
Special Bore Series

ROBUSTSLIM™ High Accuracy Low Profile Angular Contact Ball Bearings

Specially designed angular contact ball bearings reduce energy loss with swiveling (rotary/tilt) spindle heads and rotary/tilt tables



Benefits

- 1 Low Torque
- 2 Achieved NRRO Accuracy of 0.5 μm or Lower
- 3 High Moment Rigidity
- 4 Space-saving

Features of High Accuracy Low Profile Angular Contact Ball Bearings ROBUSTSLIM™

· Low Torque

Lower torque is achieved with ball bearings

· High Accuracy

NRRO (Non-Repeatable Runout) less than 0.5 μm was archived with BRSA130.

· High Rigidity

High moment stiffness on a par with crossed-roller bearings

· Space-saving

At least 35% thinner profile than a standard angular contact ball bearing

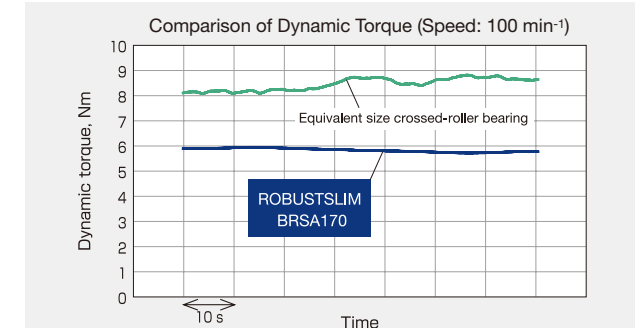

High Performance Grease for Machine Tool Spindles

ROBUSTGRD™, MTS, MTE

Features of Greases for Machine Tool Spindles

ROBUSTGRD™ Superior resistance to seizure for improved reliability against coolant intrusion at high speeds.

MTS Contains urea thickener and delivers higher heat resistance. at high speeds.

MTE Formulated for higher load capacity at high speeds.



Characteristics of each grease

Items	ROBUSTGRD™	MTS Grease	MTE Grease	Test Method	Condition
Grease code	MTR	MTS	MTE		
Thickener	Lithium Complex soap	Urea	Barium Complex soap	—	—
Base Oil	Poly- α -olefin + Mineral oil	Poly- α -olefin + Ester oil	Ester oil + Mineral oil	—	—
Kinematic Viscosity of BaseOil (mm ² /S)	32.3	22	23	JIS K2283	40°C
Worked Penetration	2	2-3	2	JISK2220 (Clause7)	25°C
Dropping Point (°C)	223	>220	>260	JIS K2220 (Clause8)	—
Evaporation (mass%)	0.6	0.3	0.2	JIS K2220 (Clause10)	99°C × 22H
Oil Separation (mass%)	2.6	0.4	1.0	JIS K2220 (Clause11)	100°C × 24H
Packing Sizes (Mass)	can (1kg)	tube (100g) can (1kg)	tube (100g) can (1kg)	—	—

Click!Speedy™ MT-Click!Speedy Analysis Tool for Machine Tool Spindle Bearings

Get detailed information on bearing solutions for machine tool spindles with our easy-to-use online tool.



※ Images are for illustrative purposes only. Actual product may vary.

Features

1. Easily select bearings from input conditions

Perform analyses for catalog bearings based on NSK's wealth of accumulated knowledge and get suggestions for bearing type, preload, and more for specified speed and cooling conditions.

2. Generate reports for candidate bearings

See NSK's recommended conditions for spindle bearing mountings, rolling fatigue life, mounted rigidity, and more in a comprehensive report for easy review.

3. Speed up design review

Improve work efficiency by deciding on bearings in the early stages of design to accelerate complex review processes.

2D Barcode Service NSK Verify

NSK Verify is a free app to combat fake bearings, help enable factory automation, and improve IT-based plant management of precision bearings for machine tools.

Scan 2D barcodes printed on NSK bearing boxes to check for bearing authenticity and instantly access inspection reports online.

※ Only bearings with an "N" marked at the bottom right of the 2D barcode are currently supported.

Features

1. Access key bearing data online

Access inspection report data for individual bearings without opening the box. Data can be exported in CSV and PDF formats, enabling plants to improve product traceability and implement automated, IT-based plant management.

2. Assess product authenticity

The app checks 2D barcodes against NSK's database and provides information to help determine if a product is genuine.

3. Quick and easy ordering with NSK sales office/distributor locator

Scan an NSK 2D barcode to display an individual product ID for quick and easy ordering from local distributors and sales offices.

4. Additional services

Conveniently access online tools from the NSK website, including product information, catalogs, Bearing Doctor troubleshooting, technical calculators, and more.



NSK website

App for iOS

App for android



Our Support for Your Bearing Selection

NSK supports customers to select the right bearings to meet their needs and ensure their NSK Super Precision Bearings provide superior performance and the highest efficiency.

The technical information mentioned in this catalog is to let you know how to select and use precision bearings for machine tools. NSK has knowledge and experience of other applications, so don't hesitate to contact us for technical assistance.

You will also find information on our latest technologies on our website to assist your selection.

NSK Web Site

<http://www.nsk.com>

Contents

Part 3. Guidelines for Bearing Selection

Selection Flow	P36
Typical High-Speed Spindle Structures	P38
Other Spindle Structures	P40
Features of Angular Contact Ball Bearings	P44
Features of Cylindrical Roller Bearings	P46

The chart below outlines the correct five step procedure to follow to select the right bearing for a typical high-speed spindle application, including the factors to be considered during each stage of the selection process.

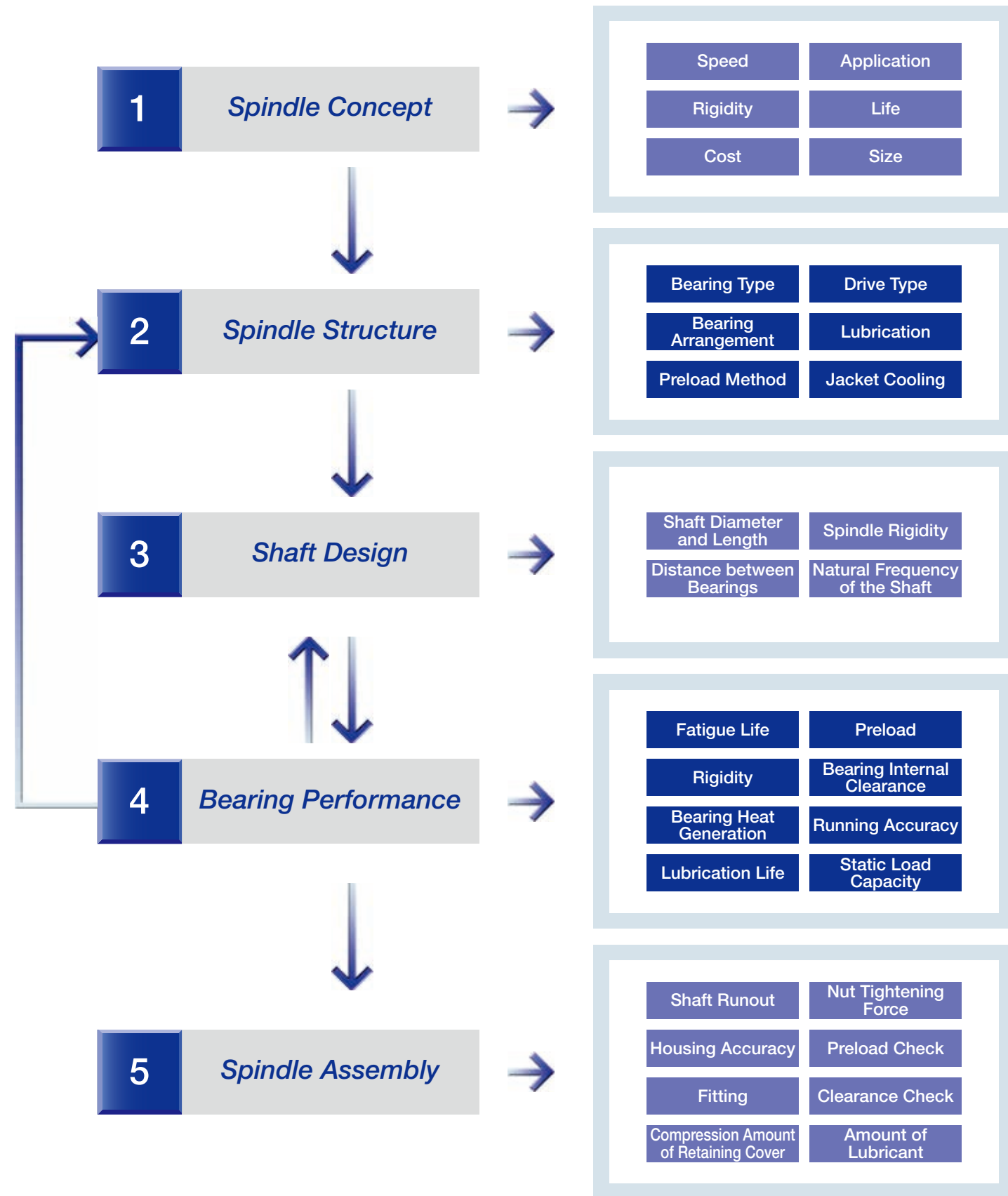

Remember, NSK technical support is always at your disposal when designing a new spindle, an ultra high-speed spindle or a spindle for a unique application. We offer customers our comprehensive experience and our expertise in advanced technology for spindle bearings.

When designing a new spindle, we recommend a thorough analysis of the desired spindle performance before selecting the bearings. In designing the spindle, it is necessary to determine which performance factors are the most important. For example, deciding if operational speed is more important than rigidity, or vice versa. Once the performance factors are prioritized proceed to the next step.

After the spindle performance analysis has been completed, the next step is to determine the structure of the spindle. Bearing type (ball bearing or roller bearing), combination (number of rows), type of drive (belt, gear, coupling or built-in motor), lubrication (grease, oil-air, oil-mist or jet) etc. need to be selected in accordance with the spindle concept. Please refer to the chart on pages 38-39 which shows the relationship between the spindle structure and its rigidity and speed.

The decision regarding the spindle structure is followed by the design of the shaft (shaft diameter and length, distance between the bearings, etc.). Shaft dimension is determined with the consideration of spindle rigidity, the dimensions of related components, and its critical speed. The radial rigidity required of the bearings is chosen based on the spindle rigidity and calculated critical speed.

After the required bearing size and type have been identified, the detailed bearing specifications are determined in the next step. Fatigue life, rigidity, heat generation etc. need to be taken into consideration in the selection of the optimal bearing and preload. Bearing preload is the most critical factor influencing bearing performance and must be considered with more care the higher the application speed. Premature failure or seizure may be the consequence of a wrong preload. Sometimes it is necessary to repeat step 3 or even steps 2 and 3 to achieve an optimal spindle design.

After the specification of the main shaft is complete, the final stage is the specification of the assembly method. Accuracy of the shaft and housing at the bearing seats is important. Specify the fit and clearance of the bearings to the shaft and housing. Use the correct nut tightening force to fix the bearings. And double check that the preload, or clearance, after the bearing has been mounted is correct.

Part 3

Part 5

Part 4

Part 5

Part 6

Speed ($d_m n$)

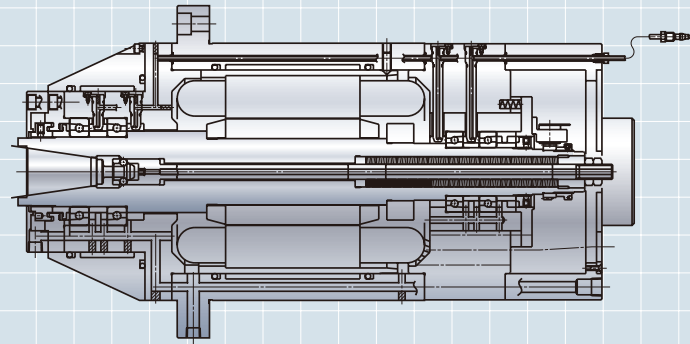

Bearing Arrangement I

Front side: Ultra high-speed angular contact ball bearing duplex set (DT)
 Rear side: Ultra high-speed angular contact ball bearing duplex set (DT)
 Spindles with this arrangement are suited for ultra high-speed operation and commonly make use of constant pressure preload. Compared to position preload, the rigidity is lower, but higher speed capability and lower temperature rise are achieved.
Applications: Machining Centers, Grinding Machines, High Frequency Spindles, etc.

Oil-air lubrication $d_m n \nearrow 3.5M$ Grease lubrication $d_m n \nearrow 2.0M$

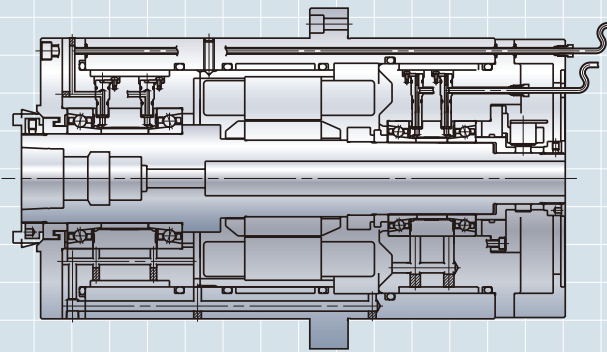

Bearing Arrangement II

Front side: Ultra high-speed angular contact ball bearing duplex set (DB)
 Rear side: Ultra high-speed angular contact ball bearing duplex set (DB)
 (Constant pressure preload is applicable with angular contact ball bearings)
 Spindles with this arrangement achieve high speeds with position preload and deliver higher radial and axial rigidity than Bearing Arrangement I. Rigidity is lower than in Bearing Arrangement III, but this arrangement is suitable for high speed operation and light cutting, and mounting is relatively easy.

Applications: Machining Centers, etc. Oil-air lubrication $d_m n \nearrow 2.5M$ Grease lubrication $d_m n \nearrow 1.5M$

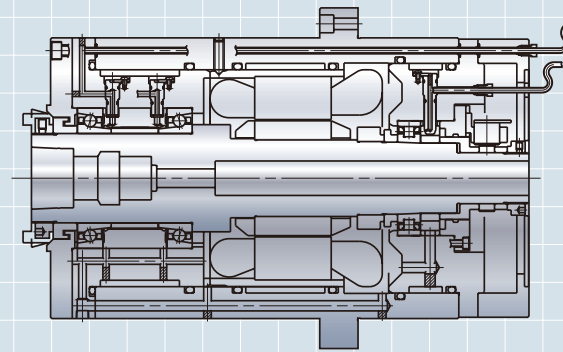

Bearing Arrangement III

Front side: Ultra high-speed angular contact ball bearing duplex set (DB)
 Rear side: Ultra high-speed single-row cylindrical roller bearing
 Spindles with this arrangement achieve high speeds with position preload and deliver higher radial and axial rigidity than Bearing Arrangement I. Considering thermal expansion of the shaft, a cylindrical roller bearing may be used on the rear side for better slide performance.

Applications: Machining Centers, etc. Oil-air lubrication $d_m n \nearrow 2.5M$ Grease lubrication $d_m n \nearrow 1.5M$

Bearing Arrangement IV

Front side: Ultra high-speed angular contact ball bearing quad set (DBB)
 Rear side: Ultra high-speed single-row cylindrical roller bearing
 (Either constant pressure or position preload is applicable with angular contact ball bearings)
 Spindles with this arrangement achieve lower operating speeds than Bearing Arrangement II but deliver higher radial and axial rigidity.

Applications: NC Lathes, NC Milling Machines, Machining Centers, etc.

Oil-air lubrication $d_m n \nearrow 2.2M$ Grease lubrication $d_m n \nearrow 1.3M$

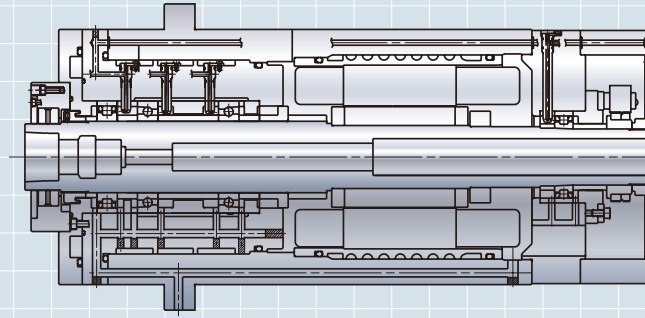
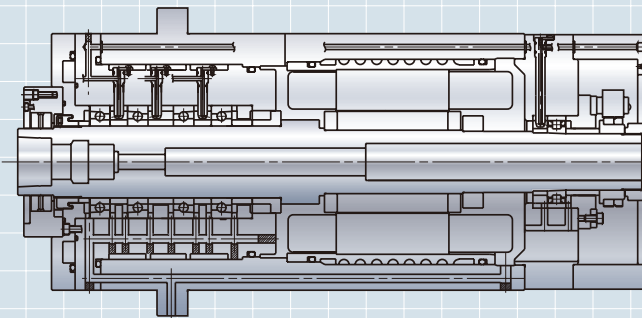

Bearing Arrangement V

Front side: Ultra high-speed single-row cylindrical roller bearing, Angular contact ball bearing duplex set (DB)
 Rear side: Ultra high-speed single-row cylindrical roller bearing
 (Either constant pressure or position preload is applicable with angular contact ball bearings)

Spindles with this arrangement achieve similar operating speeds as Bearing Arrangement III. The cylindrical roller bearing in front delivers high radial rigidity, making this structure suitable for high speed and heavy cutting.

Applications: NC Lathes, NC Milling Machines, Machining Centers, etc.

Oil-air lubrication $d_m n \nearrow 2.2M$ Grease lubrication $d_m n \nearrow 1.3M$

Bearing Arrangement VI

Front side: Ultra high-speed angular contact ball bearing triplex set (DBD)
 Rear side: Ultra high-speed single-row cylindrical roller bearing
 (Either constant pressure or position preload is applicable with angular contact ball bearings)

Spindles with this arrangement achieve lower operating speeds than Bearing Arrangement II but deliver higher radial and axial rigidity. Compared to Bearing Arrangements III and IV, this arrangement achieves both lower speed and lower rigidity.

Applications: NC Lathes, NC Milling Machines, Machining Centers, etc.

Oil-air lubrication $d_m n \nearrow 1.8M$ Grease lubrication $d_m n \nearrow 1.2M$

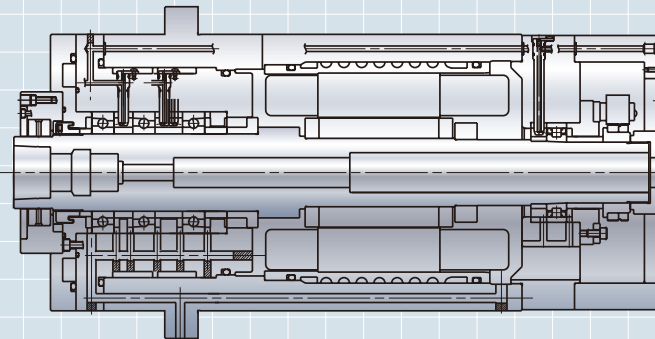

Bearing Arrangement VII

Front side: High-rigidity double-row cylindrical roller bearing, High-rigidity angular contact thrust ball bearings (DB)

Rear side: High-rigidity double-row cylindrical roller bearing
 Spindles with this arrangement achieve lower operating speeds but deliver the highest level of radial and axial rigidity.

Applications: NC Lathes, NC Milling Machines, Boring Machines, Machining Centers, etc.

Oil-air lubrication $d_m n \nearrow 1.0M$ Grease lubrication $d_m n \nearrow 0.8M$

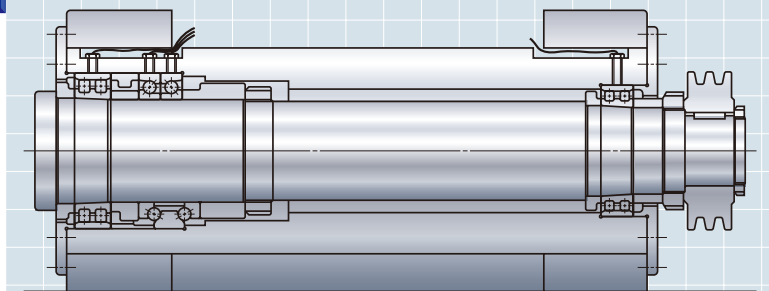

Spindle Rigidity

Boring Head

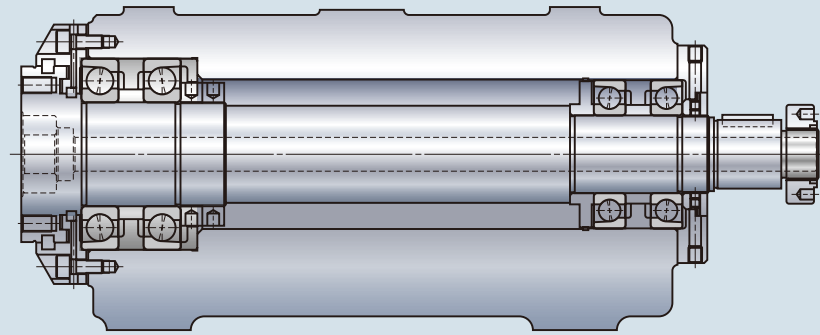

High Precision Spindle for Lathe

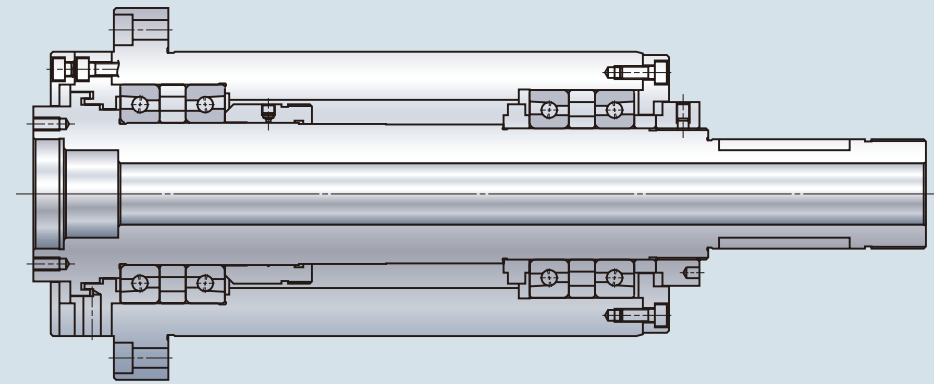

Grinding Spindle

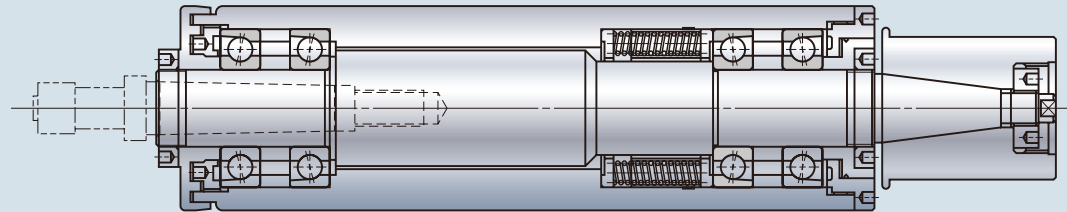

Live Center

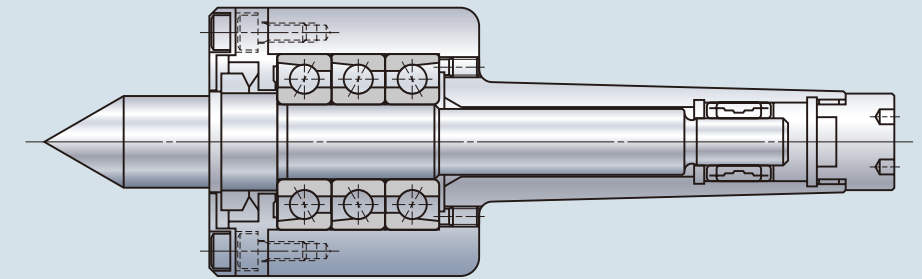

High Frequency Spindle

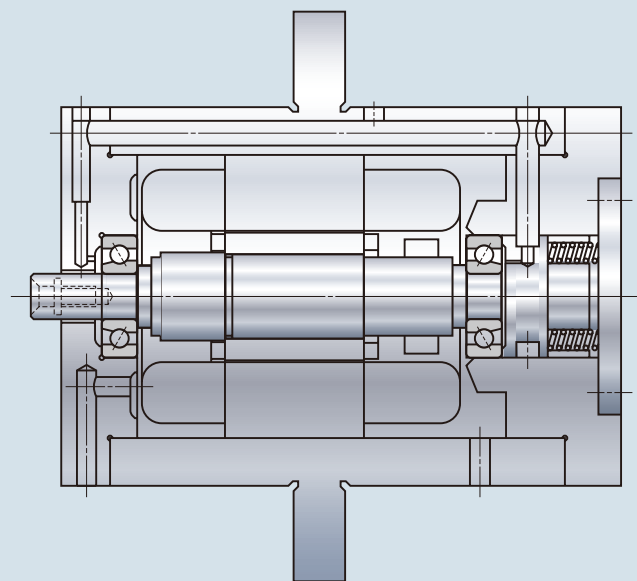

Work Head Spindle

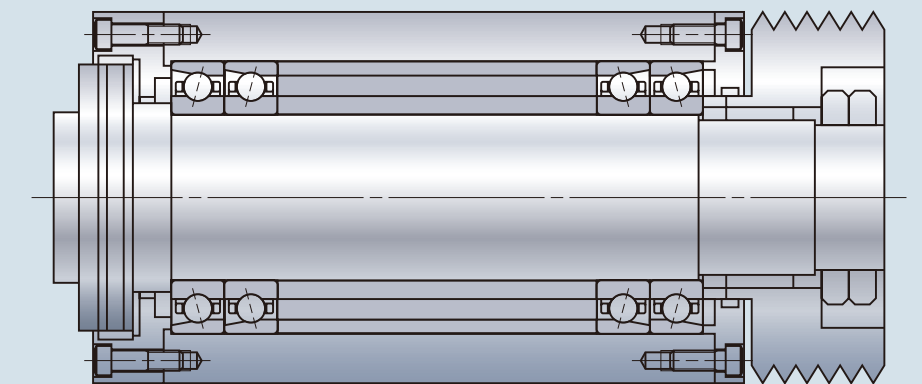

Cutting Spindle

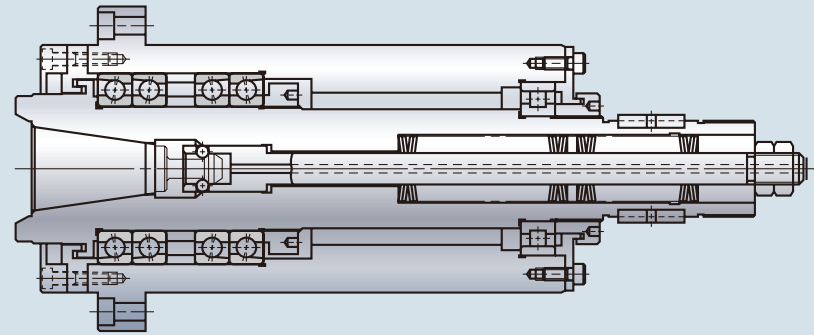

High Rigidity Spindle

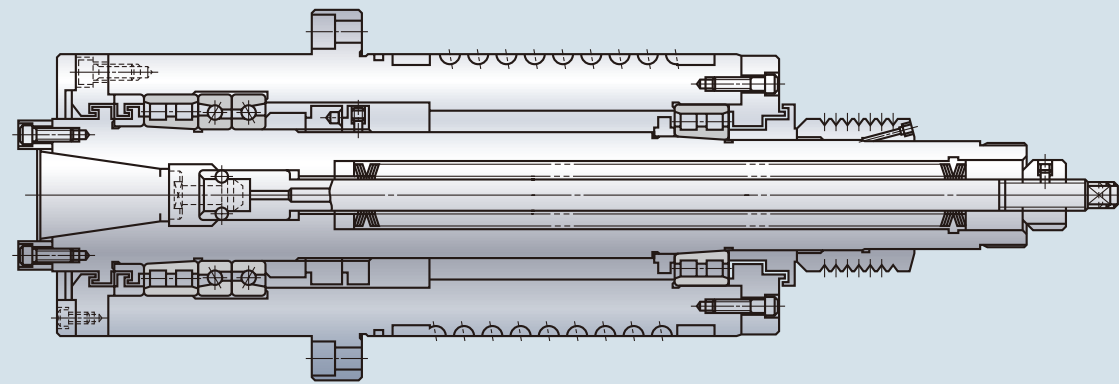

Ball Screw Support

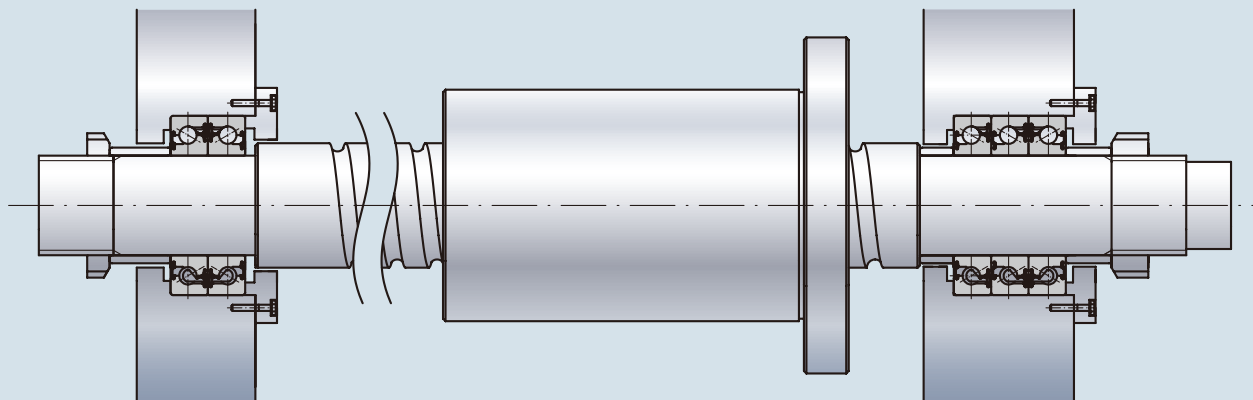

Large Lathe

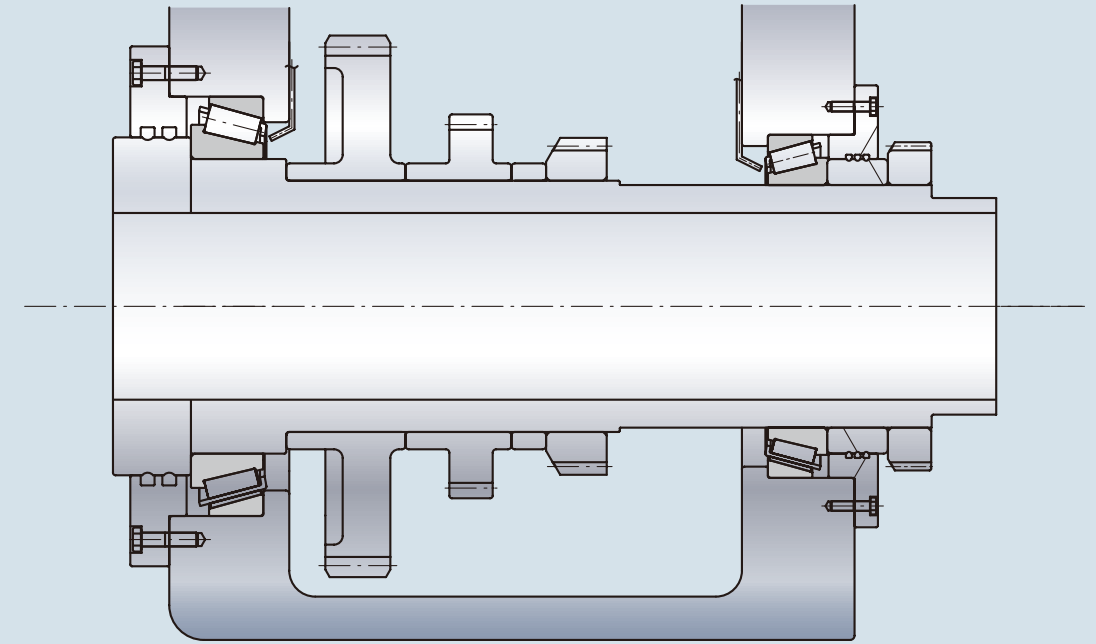

Rotary Table for Vertical Lathe

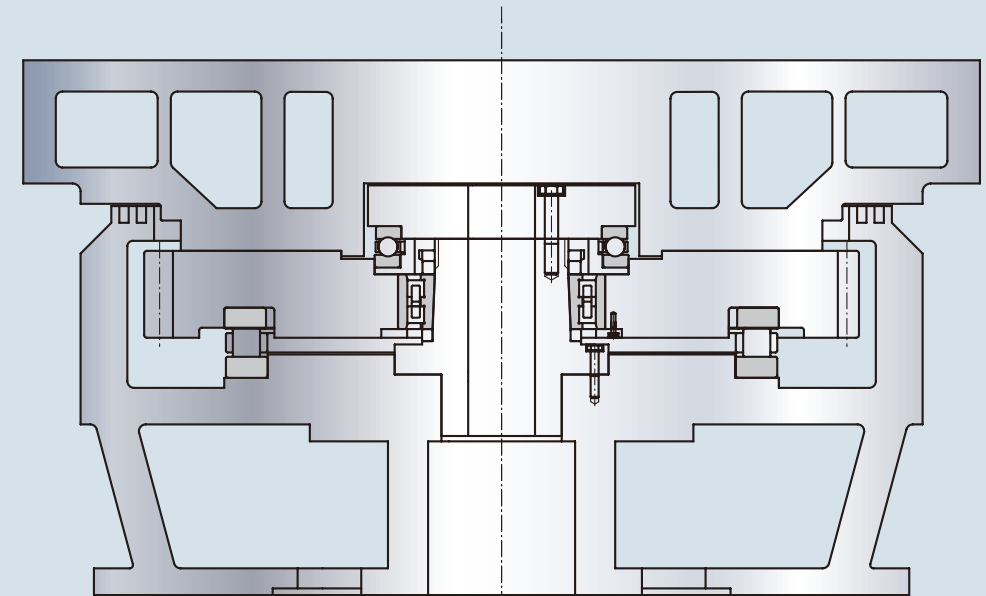

The main features of the Angular Contact Ball Bearing (ACBB)

- Predefined contact angle
- Choice of preload level
- Several combinations of bearings in rows are possible

The three properties on the left need to be taken into consideration when choosing angular contact ball bearings. To enable our customers to choose the optimal bearing for their applications, this section provides basic information on contact angle, preload and bearing arrangement.

The Effect of Contact Angle

A larger contact angle means that the bearing can support higher axial loads. Smaller contact angles, while supporting less axial load, are better suited for high speed and high radial load applications.

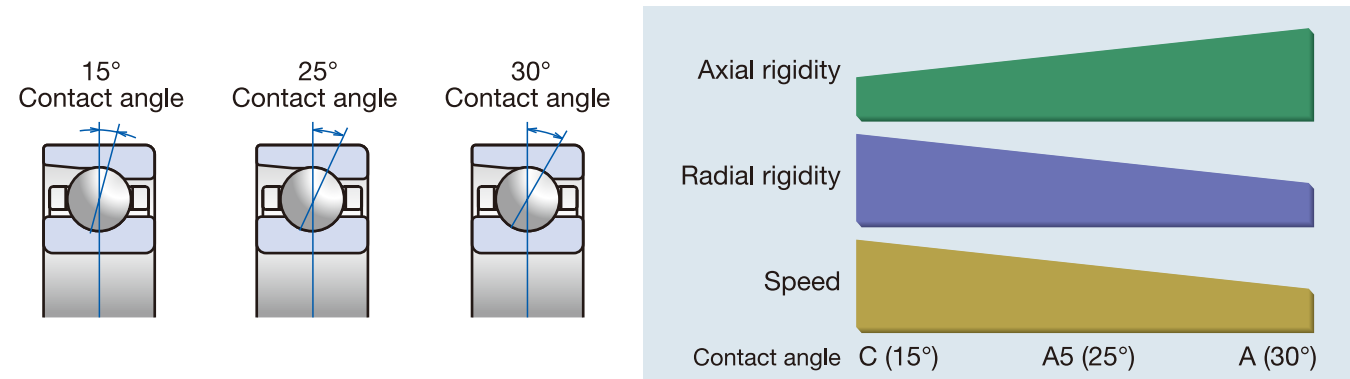

The graphs below show rigidity, limiting speed and heat generation of a 7020 angular contact ball bearing with different contact angles: C (15°), A5 (25°) and A (30°). Under the same light preload level (L), the bearing with A angle delivers the highest axial rigidity, roughly three times the axial rigidity of the bearing with C angle, but at a lower limiting speed. The bearing with C angle surpasses the bearing with A angle in terms of radial rigidity and heat generation performance.

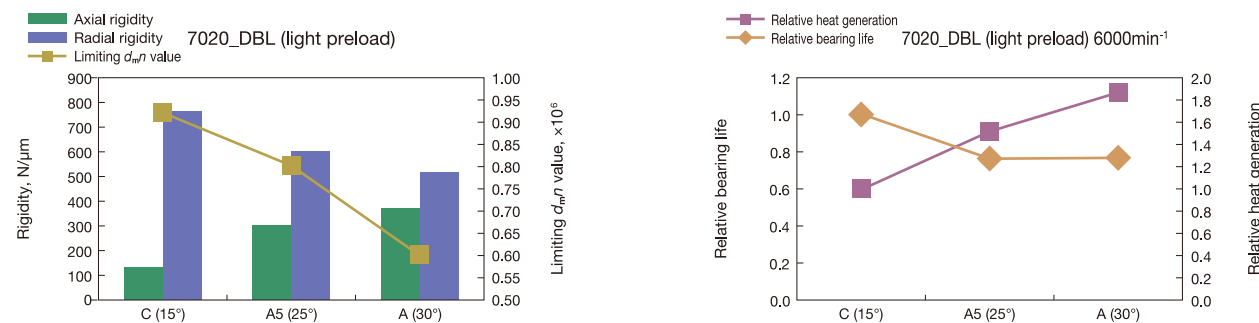

The Effect of Preload

Preload affects the performance of ACBBs in much the same way that the contact angle does. NSK has defined standard preload levels as Extra Light (EL), Light (L), Medium (M) and Heavy (H). The figures show the performance of a 7020CDB bearing combination at different preload levels. For any given contact angle, both radial and axial rigidity can be increased by increasing preload, but at the same time, heat generation will rise, while bearing life and limiting speed will decline. Higher rigidity can be achieved by sacrificing speed, and higher speed can be achieved by sacrificing rigidity to a certain degree. Caution must be exercised, as high speeds combined with too high a preload risk seizure.

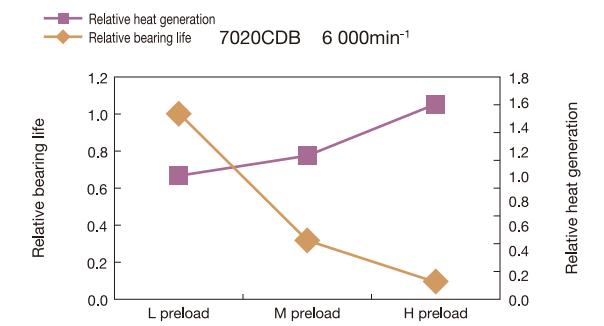
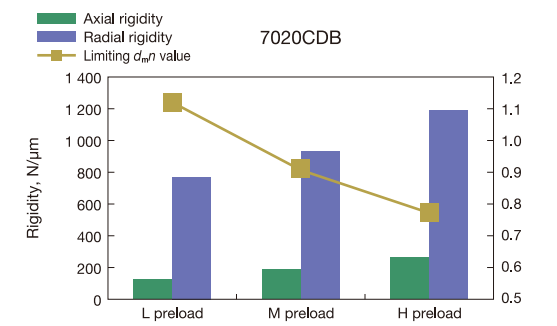
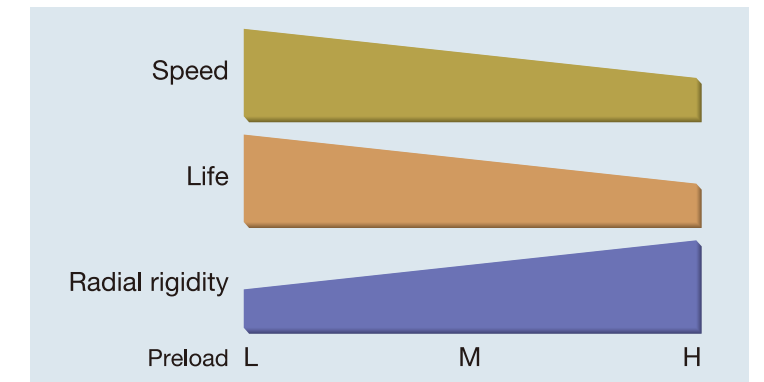
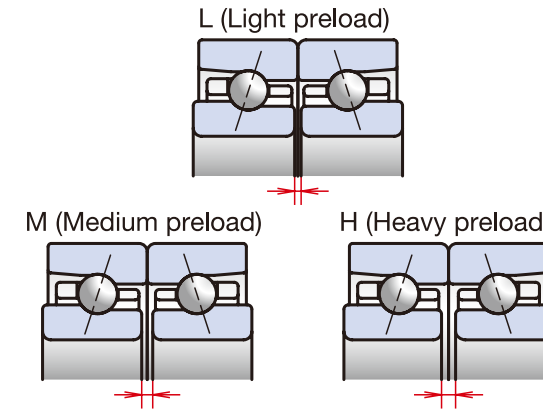

The Effect of Combination

ACBBs can be used either as single bearings or as combinations of two or more ACBBs. There are three types of combinations: Back-to-back (DB), Face-to-face (DF) or Tandem (DT). There is no limit to the number of rows.

Two row, three row and four row are the most commonly used multiple bearing sets. When the combination is held constant (back-to-back in this example), rigidity and load capacity increase with the number of rows, but limiting speed decreases.

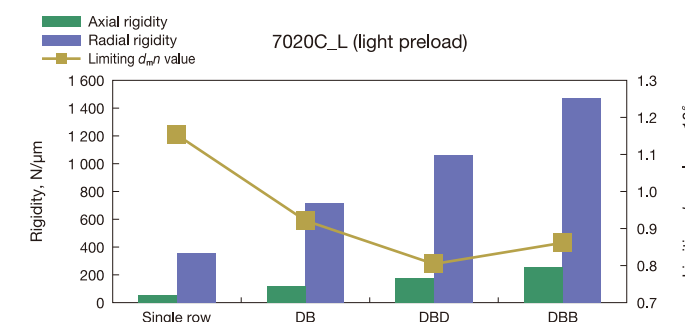
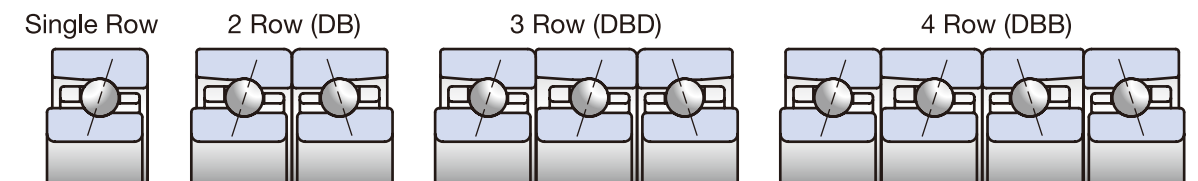

- Cylindrical roller bearings (CRB) support only radial loads, but have the advantage of a larger radial load capacity than ACBBs. Double row cylindrical roller bearings (NN and NNU types) and single row cylindrical roller bearings (N type) are available.
- In general, double row cylindrical roller bearings are used for high rigidity applications such as lathes, while single row cylindrical roller bearings are used in high-speed applications such as machining centers. The following graphs display the effect of internal radial clearance on the performance of cylindrical roller bearings.

The Effect of Internal Radial Clearance

- The performance of cylindrical roller bearings is affected by internal radial clearance after mounting. The graph shows that $0\mu\text{m}$ to slightly negative clearance is optimal in terms of both rigidity and bearing life.
- In order to achieve rigidity for fixed-end bearings, radial clearance is set to slightly below zero, but a radial clearance below $-3\mu\text{m}$ will practically not increase rigidity at all, while bearing life will fall sharply. Positive clearance of about $+3\mu\text{m}$ is commonly used in free-end bearings. However, depending on bearing size and speed a more detailed examination may be required.
- Internal radial clearance decreases during operation. This must be taken into account when setting internal radial clearance during mounting, especially with high-speed applications.

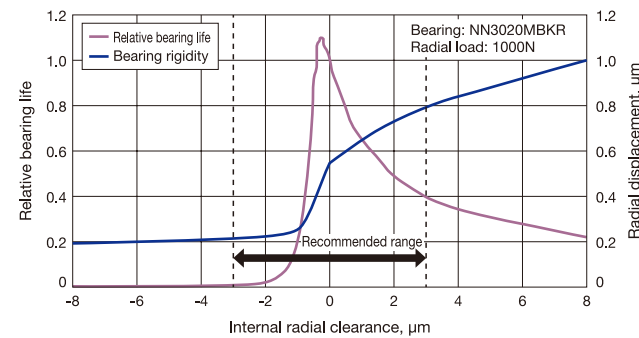

The Relationship between Internal Radial Clearance and Temperature Rise

- The figure on the right shows test results of the temperature rise in cylindrical roller bearings.
- Internal radial clearance after mounting:
- Bearing (1): $0\mu\text{m}$
- Bearing (2): $-30\mu\text{m}$
- The bearing (2) with $-30\mu\text{m}$ internal radial clearance after mounting displays a strong temperature rise and a drop in limiting speed. This illustrates that mounting a bearing with an excessively negative internal radial clearance will not allow that bearing to perform to its potential.

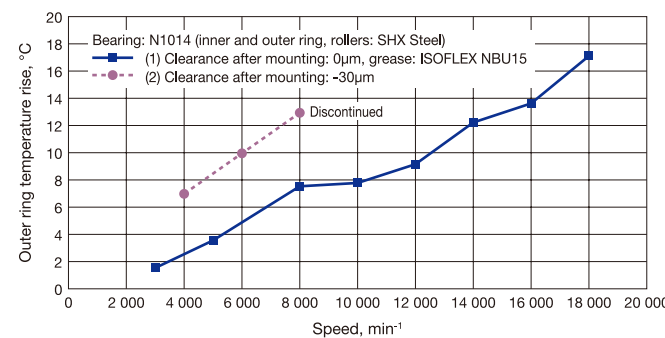

Adjusting Internal Radial Clearance After Mounting

Difference in clearance control for cylindrical bore and tapered bore

- With cylindrical bore bearings it is necessary to match the shaft and housing with the actual bore and outside diameter of the bearing, to achieve the target radial clearance.
- With tapered bore bearings, how far the bearing is driven onto the shaft determines the amount of inner ring expansion. That way internal radial clearance after mounting is easily adjusted.

Cylindrical bore

As a result of the shaft fit and housing fit, internal radial clearance will change from Δr to $\Delta r'$. Further adjustment of internal radial clearance is not possible.

Tapered bore

By pushing the inner ring onto the shaft, internal radial clearance will change from Δr to $\Delta r'$ to $\Delta r''$. Thereby the desired internal radial clearance may easily be achieved.

- The ISO standards for 1:12 tapered bores have a rather wide tolerance range for the taper angle. Therefore, for precision cylindrical roller bearings, NSK has established its own narrower tolerances:

- 1) KR tolerance has a very narrow range that is positioned towards the lower limit of the standard ISO range. The narrow tolerance of KR tapered bores supports easier clearance control during mounting. NSK applies KR tolerance as standard to bore diameters up to 400mm.
- 2) K tolerance is positioned midrange of the ISO standard. Bore dimensional tolerances are identical with those of ISO. NSK applies K tolerance to bore diameters of more than 400mm.

Please refer to page 226 for taper angle tolerances.

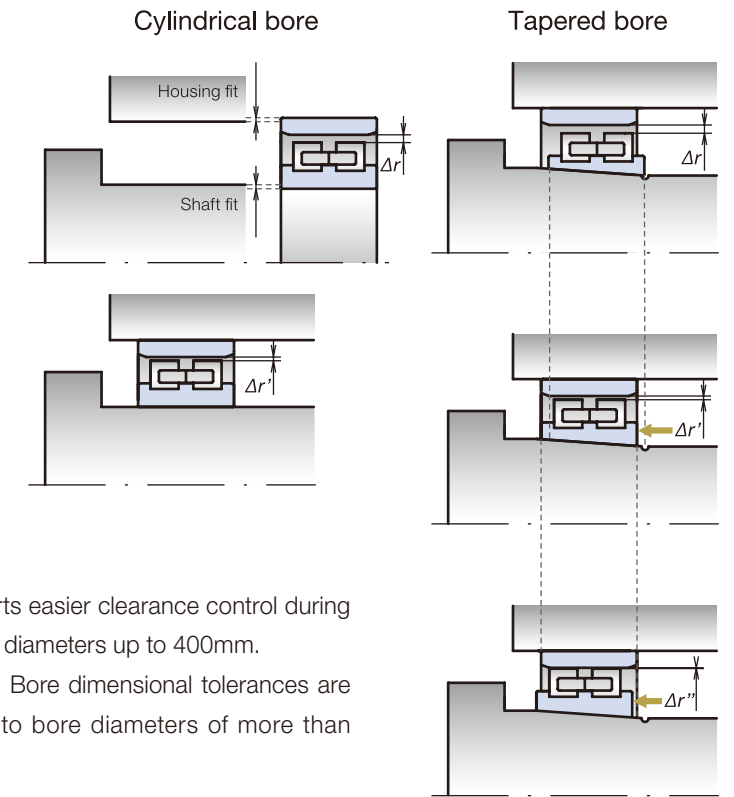

Internal Radial Clearance Classes

Three classes of internal radial clearance for tapered bore bearings are commonly in use: CC9, CC0 and CC1. It depends on the operating conditions which class is most suitable. NSK has chosen to make CC0, a well-balanced clearance, its standard internal radial clearance class because of its advantages in terms of ease of mounting and spindle accuracy.

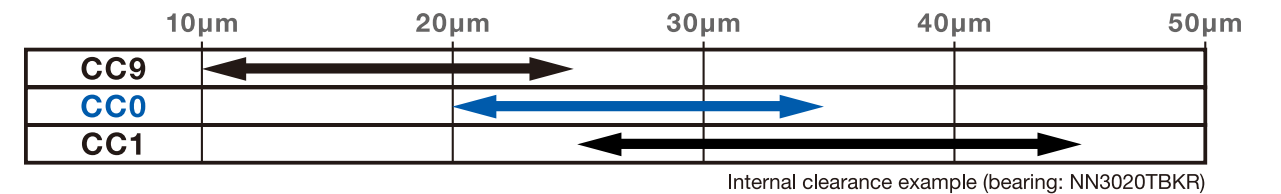

NSK's recommended clearance

- CC0
- With the upper limit of CC1 and the lower limit of CC9 omitted, this class offers medium radial clearance. Its range is also smaller than that of CC1. As it is the easiest-to-use for customers who target this range, it is the recommended clearance offered for CRB with tapered bore.

· CC9 clearance

The bearings of this class are produced with the lowest internal clearance of the three classes. Therefore, the bearing needs to be pushed onto the shaft only a short distance, which helps to avoid the negative influence of interference on bearing accuracy or deformation of the shaft bore. However, in the case of the bearing's internal clearance after manufacture being at the lower end of the range, only a small movement is required to drive the bearing onto the tapered shaft to achieve the required clearance. Depending on the load and especially in high-speed operation, pushing the bearing too short a distance onto the shaft may cause creep damage between the shaft and the inner ring of the bearing.

· CC1 clearance

Traditionally, this internal clearance class has been the most popular. There is no danger of creep damage, because the bearing will necessarily be pushed onto the shaft by a certain amount. However, in the case of the bearing's internal clearance after manufacture being at the high end of the range, the bearing will be pushed further onto the tapered shaft. This may be detrimental to bearing accuracy or cause deformation of the inside shaft bore. Especially when a thin hollow shaft has a large bore diameter, this bore diameter may easily shrink.



High-Accuracy Angular Contact Ball Bearings

Standard Series



Ultra High-Speed Angular Contact Ball Bearings NSK ROBUST Series

BASIC Series

ROBUSTDYNA™

MINI Series

Spinshot™ II

ROBUSTSHOT™

Angular Contact Ball Bearings

Angular Contact Ball Bearings 50-107

Numbering System

Bearing Tables

High-Accuracy Angular Contact Ball Bearings (Standard Series)

Ultra High-Speed Angular Contact Ball Bearings (NSK ROBUST Series)

1. Angular Contact Ball Bearings

Numbering System

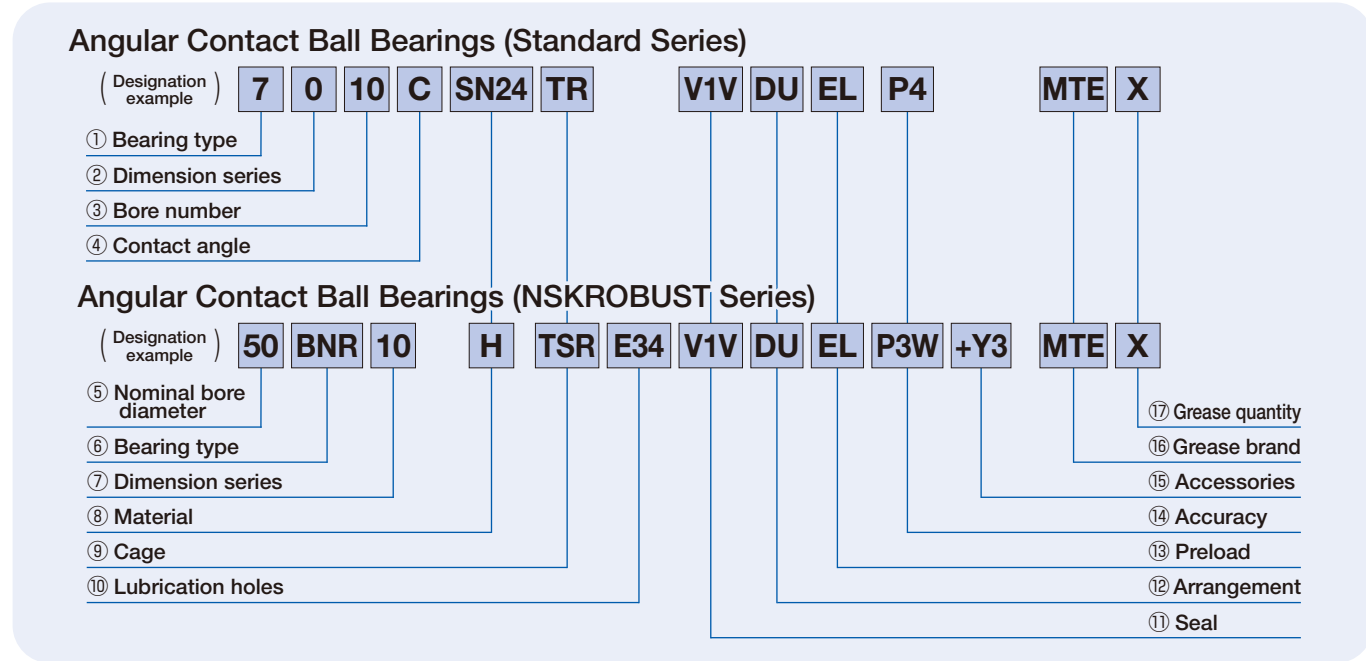

①⑥ Bearing Type Page 20, 22-23

① 7: High-Accuracy Angular Contact Ball Bearings (Standard Series)

The high-performance standard NSKHPS Series features a high basic dynamic load rating and is suitable for low to medium speed operation and high-load applications. NSK's original material evaluation technology ensures only high purity materials are used, which has the most influence on bearing life. Superior steel materials have led to a 15% extension of rolling fatigue life.

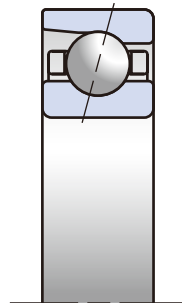

and cage and minimization of the seal labyrinth help to prevent grease leakage. Wide-width bearings (Series 29 & 20) are designed to hold more grease inside the bearing, helping to limit temperature rise and extend grease life.

MINI Series series bearings retain high radial rigidity even in high-speed operation with constant pressure preload. This makes them ideal for grinders and similar applications.

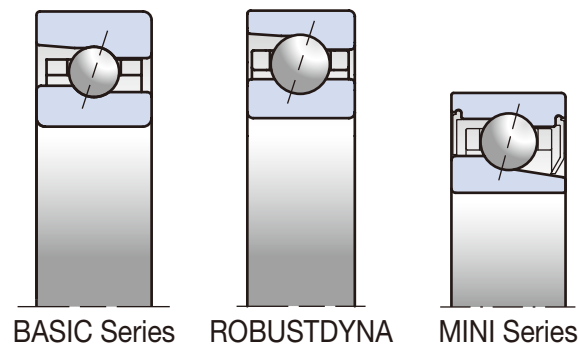

⑥ High-Speed Angular Contact Ball Bearings (NSKROBUST Series)

BNR, BER: BASIC Series
BNRD, BERD: ROBUSTDYNA
BSR: MINI Series

NSKROBUST high performance ACBBs with high rigidity and low heat generation. The results of temperature rise simulations undertaken to evaluate rolling element slip were used to optimize the design of this series.

NSKROBUST bearings are available as S, E, H, J or X types with different combinations of materials such as high-accuracy ceramic balls and heat-resistant high-speed SHX Steel, enabling the most suitable bearing for each application.

Sealed bearings are generally available for bore diameters up to 120mm. Optimization of the space between the seal

④ Contact Angle ⑥ Bearing Type Page 44-45

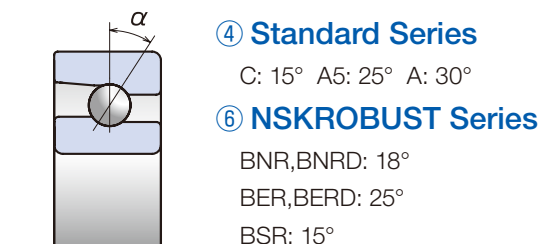

②⑦ Dimension Series

② Standard Series

9: 19 Series, 0: 10 Series, 2: 02 Series

⑦ NSKROBUST Series

19: 19 Series, 29: 29 Series, 10: 10 Series, 20: 20 Series, 02: 02 Series

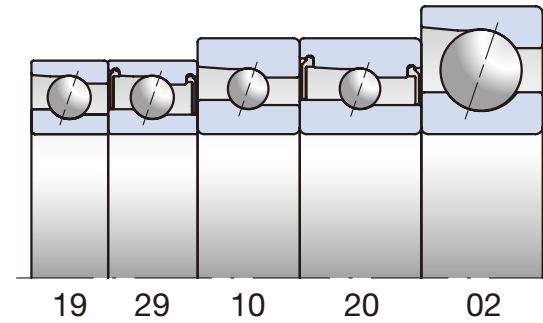

The figure above shows how bearing outside diameter and width increase for dimension series with identical bore diameters (from smallest to largest: Series 19, 29, 10, 20, 02).

Please note the 29 and 20 Series are only available as BASIC Series and MINI Series sealed ultra-high-speed angular contact ball bearings.

⑧ Material Page 14-17, 22

Standard Series

No code: Steel ball SN24: Ceramic ball

NSKROBUST Series

Type	Material	
	Inner and outer ring	Balls
S	Bearing steel (SUJ2)	Bearing steel (SUJ2)
E	Bearing steel (SUJ2)	Ultra long life rolling elements (EQTF)
H	Bearing steel (SUJ2)	Ceramic (Si ₃ N ₄)
J	Ultra Long life steel (SUJ7)	Ceramic (Si ₃ N ₄)
X	Heat resistant steel for high-speed operation (SHX)	Ceramic (Si ₃ N ₄)
XE (Spinshot™ II)	Heat resistant steel for high-speed operation (SHX)	Ceramic (Si ₃ N ₄)

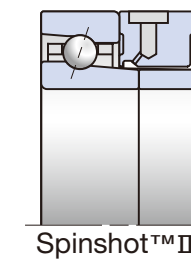

The Spinshot type has been designed for noise reduction and greater reliability of oil-air lubrication during ultra-high-speed operation.

③ Bore Number ⑤ Nominal Bore Diameter

③ Standard Series

Up to 3: Bore diameter 00: 10mm, 01: 12mm, 02: 15mm, 03: 17mm
4 and above: Bore diameter = Bore number x 5 (mm)

⑤ ROBUST Series

Nominal bore diameter = Bore dimension (mm)

⑩ Lubrication Holes Page 22

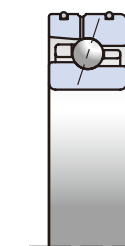

⑩ NSKROBUST Series

E34: Direct lubrication bearing
Space-saving bearings designed specifically for oil-air lubrication, equipped with a lubrication groove, lubrication holes, and an O-ring groove on the outer ring.
Available for NSKROBUST Series only.

⑨ Cage Page 18

	Code	Material	Guiding	Features	Limiting Speed (d _m n value)	Availability
	TYN	Polyamide resin	Ball guided	Excellent wear and noise characteristics, especially effective with grease lubrication	Oil: 1.4 million Grease: 1.2 million	· Standard Series · NSKROBUST Series (not available for 19 Series sealed type)
	TR T TX TA	Phenolic resin	Outer ring guided	Stable cage rotation in high-speed operation	2.8 million	TR: Standard Series, ROBUSTDYNA T: BASIC Series, MINI Series TX: BASIC Series (With 19Series sealed type) TA: MINI Series (sealed type)
	TSR	PPS resin	Outer ring guided	Reduction of non-repeatable run-out (NRRO). Low temperature rise in ultra-high-speed operation due to unique design with enhanced oil drain	3.0 million	· BASIC Series
	MY	Brass	Ball guided	Excellent noise and temperature rise characteristics. Extended grease life.	Oil: 0.8 million Grease: 0.7 million	· Standard Series · NSKROBUST Series only for large bearings not equipped with TYN cages

1. Angular Contact Ball Bearings

Bore Diameter **5-10mm**

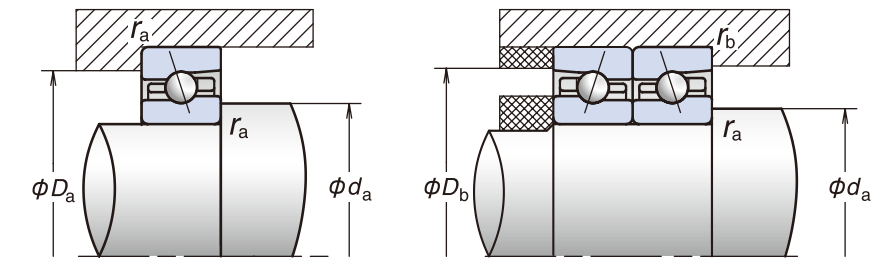
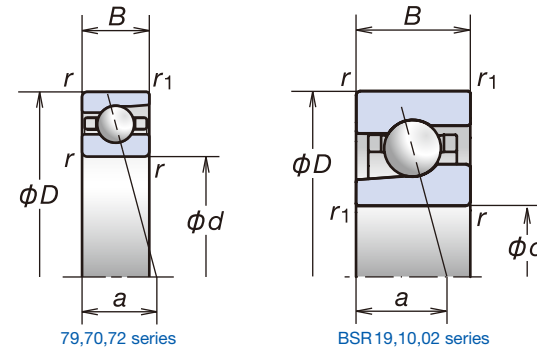

Designation (*)	Boundary Dimensions (mm)					Basic Load Ratings (kN)		Permissible Axial Load (kN)	Contact Angle (°)	Factor f_0	Effective Load Center (mm) a	Limiting Speeds (min ⁻¹)	
	d	D	B	r (min.)	r_1 (min.)	C_r (Dynamic)	C_{or} (Static)					Grease	Oil
725C	5	16	5	0.3	0.15	2.15	0.660	0.545	15	12.6	3.9	110 000	167 000
725A	5	16	5	0.3	0.15	2.02	0.620	0.665	30	—	5.5	72 000	96 000
706C	6	17	6	0.3	0.15	2.71	0.845	0.765	15	12.4	4.5	100 000	153 000
706A	6	17	6	0.3	0.15	2.56	0.795	0.725	30	—	6.3	66 000	87 000
*6BSR10S	6	17	6	0.3	0.15	1.70	0.445	0.525	15	6.6	4.5	140 000	192 000
*6BSR10H	6	17	6	0.3	0.15	1.71	0.425	0.345	15	6.6	4.5	166 000	244 000
*6BSR10X	6	17	6	0.3	0.15	2.71	0.425	0.345	15	6.6	4.5	192 000	261 000
726C	6	19	6	0.3	0.15	3.00	1.00	0.835	15	12.8	4.7	92 000	140 000
726A	6	19	6	0.3	0.15	2.82	0.940	0.395	30	—	6.6	60 000	80 000
707C	7	19	6	0.3	0.15	3.00	1.00	0.835	15	12.8	4.7	89 000	135 000
707A	7	19	6	0.3	0.15	2.82	0.940	0.375	30	—	6.6	58 000	77 000
*7BSR10S	7	19	6	0.3	0.15	1.98	0.570	0.675	15	7.1	4.7	124 000	170 000
*7BSR10H	7	19	6	0.3	0.15	1.98	0.545	0.440	15	7.1	4.7	147 000	216 000
*7BSR10X	7	19	6	0.3	0.15	3.15	0.545	0.440	15	7.1	4.7	170 000	231 000
708C	8	22	7	0.3	0.15	4.45	1.54	1.30	15	12.7	5.5	77 000	117 000
708A	8	22	7	0.3	0.15	4.20	1.45	1.02	30	—	7.8	50 000	67 000
*8BSR10S	8	22	7	0.3	0.15	2.91	0.835	1.01	15	7.0	5.5	107 000	147 000
*8BSR10H	8	22	7	0.3	0.15	2.91	0.800	0.660	15	7.0	5.5	127 000	187 000
*8BSR10X	8	22	7	0.3	0.15	4.60	0.800	0.660	15	7.0	5.5	147 000	200 000
728C	8	24	8	0.3	0.15	4.50	1.58	1.33	15	13.1	6.1	72 000	110 000
728A	8	24	8	0.3	0.15	4.25	1.48	0.610	30	—	8.6	47 000	63 000
7900C	10	22	6	0.3	0.15	3.80	1.52	1.23	15	14.1	5.1	71 900	109 000
7900CSN24	10	22	6	0.3	0.15	3.80	1.46	1.42	15	14.1	5.1	93 800	143 000
7900A5	10	22	6	0.3	0.15	3.65	1.45	1.44	25	—	6.7	62 500	93 800
7900A5SN24	10	22	6	0.3	0.15	3.65	1.40	1.71	25	—	6.7	81 300	122 000
*10BSR19S	10	22	6	0.3	0.15	2.24	0.715	0.855	15	7.4	5.1	100 000	138 000
*10BSR19H	10	22	6	0.3	0.15	2.24	0.685	0.560	15	7.4	5.1	119 000	175 000
*10BSR19X	10	22	6	0.3	0.15	3.55	0.685	0.560	15	7.4	5.1	138 000	188 000
7000C	10	26	8	0.3	0.15	6.70	2.49	2.16	15	12.6	6.4	63 900	97 300
7000CSN24	10	26	8	0.3	0.15	6.60	2.33	2.36	15	12.6	6.4	83 400	127 000
7000A5	10	26	8	0.3	0.15	6.50	2.41	2.48	25	—	8.2	55 600	83 400
7000A5SN24	10	26	8	0.3	0.15	6.40	2.25	2.94	25	—	8.2	72 300	108 000
7000A	10	26	8	0.3	0.15	6.30	2.34	1.91	30	—	9.2	41 700	55 600
*10BSR10S	10	26	8	0.3	0.15	3.80	1.18	1.44	15	7.1	6.4	88 900	123 000
*10BSR10H	10	26	8	0.3	0.15	3.80	1.13	0.94	15	7.1	6.4	106 000	156 000
*10BSR10X	10	26	8	0.3	0.15	6.05	1.13	0.94	15	7.1	6.4	123 000	167 000
7200C	10	30	9	0.6	0.3	6.80	2.61	2.16	15	13.2	7.2	57 500	87 500
7200CSN24	10	30	9	0.6	0.3	6.70	2.44	2.48	15	13.2	7.2	75 000	114 000
7200A5	10	30	9	0.6	0.3	6.55	2.51	2.49	25	—	9.2	50 000	75 000
7200A5SN24	10	30	9	0.6	0.3	6.45	2.35	2.96	25	—	9.2	65 000	97 500
7200A	10	30	9	0.6	0.3	6.35	2.44	1.92	30	—	10.3	37 500	50 000
*10BSR02S	10	30	9	0.6	0.3	4.85	1.48	1.81	15	6.7	7.2	80 000	110 000
*10BSR02H	10	30	9	0.6	0.3	4.85	1.41	1.18	15	6.7	7.2	95 000	140 000
*10BSR02X	10	30	9	0.6	0.3	7.70	1.41	1.18	15	6.7	7.2	110 000	150 000

Abutment and Fillet Dimensions (mm)					Preload (DB and DF Arrangement) (N)				Axial Rigidity (DB and DF Arrangement) (N/μm)				Measured Axial Clearance (μm)				Mass (kg) (approx.)
d_a (min.)	D_a (max.)	D_b (max.)	r_a (max.)	r_b (max.)	EL	L	M	H	EL	L	M	H	EL	L	M	H	
7.5	13.5	—	0.3	—	1.2	5.5	12	25	4.0	7.3	10	14	10	7	4	0	
7.5	13.5	—	0.3	—	5	10	25	53	19	24	33	43	3	2	0	-3	
8.5	14.5	—	0.3	—	1.5	7.9	15	32	4.3	8.3	11	15	10	6	3	-2	
8.5	14.5	—	0.3	—	4.9	17	25	53	19	29	33	42	3	1	0	-3	
8.5	14.5	—	0.3	—	3.4	6.7	16	—	5.7	7.5	11	—	9	7	3	—	
8.5	14.5	—	0.3	—	2.1	5.4	15	—	5.4	7.6	11	—	9	7	3	—	
8.5	14.5	—	0.3	—	2.1	5.4	15	—	5.4	7.6	11	—	9	7	3	—	
8.5	16.5	—	0.3	—	1.8	9.2	18	37	5	10	13	28	9	5	2	-3	
8.5	16.5	—	0.3	—	3.7	16	34	69	18	31	40	52	3	1	-1	-4	
9.5	16.5	—	0.3	—	1.8	9.2	18	37	5.1	10	13	18	9	5	2	-3	
9.5	16.5	—	0.3	—	3.7	16	34	69	18	31	40	52	3	1	-1	-4	
9.5	16.5	—	0.3	—	5.2	9.5	18	—	7.7	9.7	12	—	7	5	2	—	
9.5	16.5	—	0.3	—	3.8	8.2	17	—	7.6	10	14	—	7	5	2	—	
9.5	16.5	—	0.3	—	3.8	8.2	17	—	7.6	10	14	—	7	5	2	—	
10.5	19.5	—	0.3	—	4.2	14	29	59	7.5	12	17	23	7	3	-1	-7	
10.5	19.5	—	0.3	—	8.1	25	46	88	26	39	49	63	2	0	-2	-5	
10.5	19.5	—	0.3	—	7.3	12	21	—	8.7	11	13	—	6	4	1	—	
10.5	19.5	—	0.3	—	5.9	11	21	—	9.0	11	15	—	6	4	1	—	
10.5	19.5	—	0.3	—	5.9	11	21	—	9.0	11	15	—	6	4	1	—	
10.5	21.5	—	0.3	—	4.2	14	29	59	7.5	12	17	23	7	3	-1	-7	
10.5	21.5	—	0.3	—	8.1	25	46	88	26	39	49	63	2	0	-2	-5	
12.5	19.5	20.8	0.3	0.15	7.0	16	29	58	10	15	19	27	5	2	-1	-6	
12.5	19.5	20.8	0.3	0.15	5.7	16	30	62	11	16	21	30	5	2	-1	-6	
12.5	19.5	20.8	0.3	0.15	9.8	17	55	94	24	29	46	58	2	1	-3	-6	
12.5	19.5	20.8	0.3	0.15	8.5	16	59	103	26	32	53	66	2	1	-3	-6	
12.5	19.5	20.8	0.3	0.15	5.9	14	21	—	8.9	12	15	—	6	3	1	—	
12.5	19.5	20.8	0.3	0.15	4.5	13	20	—	9.0	13	16	—	6	3	1	—	
12.5	19.5	20.8	0.3	0.15	4.5	13	20	—	9.0	13	16	—	6	3	1	—	
12.5	23.5	24.8	0.3	0.15	13	25	49	96	13	17	23	31	3	0	-5	-12	
12.5	23.5	24.8	0.3	0.15	12	25	52	106	14	19	26	36	3	0	-5	-12	
12.5	23.5	24.8	0.3	0.15	17	43	78	153	29	41	52	68	1	-2	-5	-10	
12.5	23.5	24.8	0.3	0.15	16	46	86	172	32	47	59	78	1	-2	-5	-10	
12.5	23.5	24.8	0.3	0.15	25	97	202	333	44	72	94	115	0	-5	-10	-15	
12.5	23.5	24.8	0.3	0.15	8.4	17	37	—	10	13	18	—	5	2	-3	—	
12.5	23.5	24.8	0.3	0.15	7.1	17	39	—	11	15	21	—	5	2	-3	—	
12.5	23.5	24.8	0.3	0.15	7.1	17	39	—	11	15	21	—	5	2	-3	—	
15	25	27.5	0.6	0.3	13	29	68	150	13	18	26	39	3	-1	-8	-18	
15	25	27.5	0.6	0.3	12	29	73	167	14	20	30	45	3	-1	-8	-18	
15	25	27.5	0.6	0.3	17	43	106	188	29	41	58	74	1	-2	-7	-12	
15	25	27.5	0.6	0.3	16	46	117	213	32	47	67	86	1	-2	-7	-12	
15	25	27.5	0.6	0.3	25	97	202	—	44	72	95	—	0	-5	-10	—	
15	25	27.5	0.6	0.3	11	25	51	—	11	15	20	—	4	0	-6	—	
15	25	27.5	0.6	0.3	10	25	54	—	12	17	23	—	4	0	-6	—	
15	25	27.5	0.6	0.3	10	25	54	—	12	17	23	—	4	0	-6	—	

(*) Bearings denoted by an asterisk (*) are available with seals. Some series are comprised exclusively of sealed bearings.
 (†) For details on permissible axial load, refer to Page 199.
 (‡) For details on limiting speeds, refer to Page 216. See Page 51 for cage differences and their impact on $d_{m1}n$ values.

Calculation of radial rigidity
 Multiply axial rigidity by the appropriate factor in Table A.

Preload	EL	L	M	H
15°	6.5	6.0	5.0	4.5
25°	2.0			
30°	1.4			

1. Angular Contact Ball Bearings

Bore Diameter **12, 15 mm**

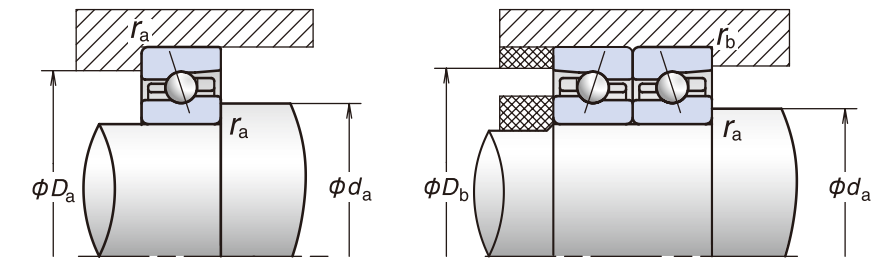
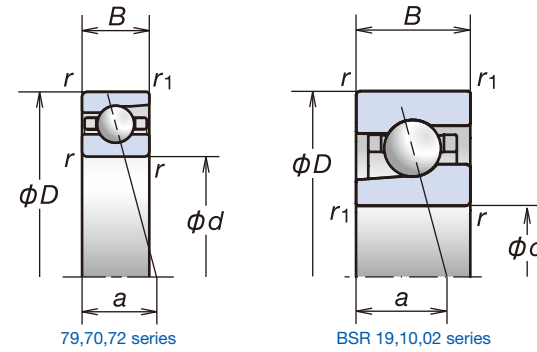

Designation (*)	Boundary Dimensions (mm)					Basic Load Ratings (kN)		Permissible Axial Load (*) (kN)	Contact Angle (°)	Factor f ₀	Effective Load Center (mm) a	Limiting Speeds (*) (min ⁻¹)	
	d	D	B	r (min.)	r ₁ (min.)	C _r (Dynamic)	C _{or} (Static)					Grease	Oil
7901C	12	24	6	0.3	0.15	4.25	1.86	1.45	15	14.7	5.4	63 900	97 300
7901CSN24	12	24	6	0.3	0.15	4.25	1.79	1.72	15	14.7	5.4	83 300	127 000
7901A5	12	24	6	0.3	0.15	4.05	1.77	1.71	25	—	7.2	55 600	83 400
7901A5SN24	12	24	6	0.3	0.15	4.05	1.71	2.04	25	—	7.2	72 200	108 000
*12BSR19S	12	24	6	0.3	0.15	2.46	0.850	1.02	15	7.7	5.4	88 900	123 000
*12BSR19H	12	24	6	0.3	0.15	2.46	0.815	0.665	15	7.7	5.4	106 000	156 000
*12BSR19X	12	24	6	0.3	0.15	3.90	0.815	0.665	15	7.7	5.4	123 000	167 000
7001C	12	28	8	0.3	0.15	7.30	2.90	2.40	15	13.2	6.7	57 500	87 500
7001CSN24	12	28	8	0.3	0.15	7.20	2.71	2.75	15	13.2	6.7	75 000	114 000
7001A5	12	28	8	0.3	0.15	7.05	2.79	2.82	25	—	8.7	50 000	75 000
7001A5SN24	12	28	8	0.3	0.15	6.90	2.61	3.44	25	—	8.7	65 000	97 500
7001A	12	28	8	0.3	0.15	6.85	2.71	2.13	30	—	9.8	37 500	50 000
*12BSR10S	12	28	8	0.3	0.15	4.05	1.33	1.63	15	7.4	6.7	80 000	110 000
*12BSR10H	12	28	8	0.3	0.15	4.05	1.27	1.06	15	7.4	6.7	95 000	140 000
*12BSR10X	12	28	8	0.3	0.15	6.45	1.27	1.06	15	7.4	6.7	110 000	150 000
7201C	12	32	10	0.6	0.3	9.95	3.85	3.45	15	12.5	7.9	52 300	79 600
7201CSN24	12	32	10	0.6	0.3	9.85	3.60	3.75	15	12.5	7.9	68 200	104 000
7201A5	12	32	10	0.6	0.3	9.65	3.70	3.55	25	—	10.1	45 500	68 200
7201A5SN24	12	32	10	0.6	0.3	9.50	3.50	4.23	25	—	10.1	59 100	88 700
7201A	12	32	10	0.6	0.3	9.40	3.65	2.72	30	—	11.4	34 100	45 500
*12BSR02S	12	32	10	0.6	0.3	6.40	1.98	2.45	15	6.6	7.9	72 800	100 000
*12BSR02H	12	32	10	0.6	0.3	6.40	1.89	1.59	15	6.6	7.9	86 400	128 000
*12BSR02X	12	32	10	0.6	0.3	10.1	1.89	1.59	15	6.6	7.9	100 000	137 000
7902C	15	28	7	0.3	0.15	6.00	2.64	1.93	15	14.5	6.4	53 500	81 400
7902CSN24	15	28	7	0.3	0.15	6.15	2.61	2.30	15	14.5	6.4	69 800	106 000
7902A5	15	28	7	0.3	0.15	5.75	2.53	2.22	25	—	8.5	46 600	69 800
7902A5SN24	15	28	7	0.3	0.15	5.85	2.49	2.63	25	—	8.5	60 500	90 700
*15BSR19S	15	28	7	0.3	0.15	3.75	1.31	1.60	15	7.7	6.4	74 500	103 000
*15BSR19H	15	28	7	0.3	0.15	3.75	1.26	1.04	15	7.7	6.4	88 400	131 000
*15BSR19X	15	28	7	0.3	0.15	5.90	1.26	1.04	15	7.7	6.4	103 000	140 000
7002C	15	32	9	0.3	0.15	7.85	3.40	2.63	15	14.1	7.6	49 000	74 500
7002CSN24	15	32	9	0.3	0.15	7.75	3.15	3.12	15	14.1	7.6	63 900	97 100
7002A5	15	32	9	0.3	0.15	7.55	3.25	3.05	25	—	10	42 600	63 900
7002A5SN24	15	32	9	0.3	0.15	7.40	3.05	3.64	25	—	10	55 400	83 000
7002A	15	32	9	0.3	0.15	7.30	3.15	2.36	30	—	11.3	32 000	42 600
*15BSR10S	15	32	9	0.3	0.15	5.30	1.72	2.12	15	7.2	7.6	68 100	93 700
*15BSR10H	15	32	9	0.3	0.15	5.25	1.65	1.38	15	7.2	7.6	80 900	120 000
*15BSR10X	15	32	9	0.3	0.15	8.35	1.65	1.38	15	7.2	7.6	93 700	128 000
7202C	15	35	11	0.6	0.3	10.9	4.55	3.85	15	13.2	8.8	46 000	70 000
7202CSN24	15	35	11	0.6	0.3	10.8	4.25	4.55	15	13.2	8.8	60 000	91 200
7202A5	15	35	11	0.6	0.3	10.5	4.35	3.95	25	—	11.3	40 000	60 000
7202A5SN24	15	35	11	0.6	0.3	10.4	4.10	5.50	25	—	11.3	52 000	78 000
7202A	15	35	11	0.6	0.3	10.2	4.25	3.00	30	—	12.7	30 000	40 000
*15BSR02S	15	35	11	0.6	0.3	7.30	2.34	2.90	15	6.8	8.8	64 000	88 000
*15BSR02H	15	35	11	0.6	0.3	7.30	2.24	1.89	15	6.8	8.8	76 000	112 000
*15BSR02X	15	35	11	0.6	0.3	11.6	2.24	1.89	15	6.8	8.8	88 000	120 000

Abutment and Fillet Dimensions (mm)					Preload (DB and DF Arrangement) (N)				Axial Rigidity (DB and DF Arrangement) (N/μm)				Measured Axial Clearance (μm)				Mass (kg) (approx.)
d _a (min.)	D _a (max.)	D _b (max.)	r _a (max.)	r _b (max.)	EL	L	M	H	EL	L	M	H	EL	L	M	H	
14.5	21.5	22.8	0.3	0.15	8.6	16	41	77	12	16	25	34	4	2	-3	-8	0.011
14.5	21.5	22.8	0.3	0.15	7.3	15	43	84	13	17	27	38	4	2	-3	-8	0.010
14.5	21.5	22.8	0.3	0.15	16	25	59	120	32	38	53	70	1	0	-3	-7	0.011
14.5	21.5	22.8	0.3	0.15	15	25	63	134	35	43	60	81	1	0	-3	-7	0.010
14.5	21.5	22.8	0.3	0.15	4.7	13	25	—	9.0	13	17	—	6	3	0	—	0.012
14.5	21.5	22.8	0.3	0.15	3.3	12	25	—	8.8	14	19	—	6	3	0	—	0.011
14.5	21.5	22.8	0.3	0.15	3.3	12	25	—	8.8	14	19	—	6	3	0	—	0.011
14.5	25.5	26.8	0.3	0.15	13	25	57	120	14	18	26	37	3	0	-6	-14	0.021
14.5	25.5	26.8	0.3	0.15	12	25	61	133	15	20	29	42	3	0	-6	-14	0.019
14.5	25.5	26.8	0.3	0.15	16	45	97	203	31	45	60	81	1	-2	-6	-12	0.021
14.5	25.5	26.8	0.3	0.15	15	47	108	230	34	51	69	94	1	-2	-6	-12	0.019
14.5	25.5	26.8	0.3	0.15	25	104	218	363	48	78	104	127	0	-5	-10	-15	0.021
14.5	25.5	26.8	0.3	0.15	10	21	43	—	12	15	20	—	4	1	-4	—	0.023
14.5	25.5	26.8	0.3	0.15	9.2	20	45	—	12	17	23	—	4	1	-4	—	0.021
14.5	25.5	26.8	0.3	0.15	9.2	20	45	—	12	17	23	—	4	1	-4	—	0.021
17	27	29.5	0.6	0.3	20	39	99	197	16	21	32	46	1	-3	-12	-22	0.036
17	27	29.5	0.6	0.3	20	41	109	221	18	24	37	52	1	-3	-12	-22	0.031
17	27	29.5	0.6	0.3	34	56	146	287	40	49	70	92	-1	-3	-9	-16	0.036
17	27	29.5	0.6	0.3	35	61	164	329	46	56	81	107	-1	-3	-9	-16	0.031
17	27	29.5	0.6	0.3	25	104	218	361	48	78	103	126	0	-5	-10	-15	0.030
17	27	29.5	0.6	0.3	14	33	63	—	13	18	23	—	3	-2	-8	—	0.039
17	27	29.5	0.6	0.3	13	34	68	—	14	20	26	—	3	-2	-8	—	0.035
17	27	29.5	0.6	0.3	13	34	68	—	14	20	26	—	3	-2	-8	—	0.035
17.5	25.5	26.8	0.3	0.15	12	25	47	104	14	20	26	39	3	0	-4	-11	0.016
17.5	25.5	26.8	0.3	0.15	11	25	50	114	15	22	29	44	3	0	-4	-11	0.014
17.5	25.5	26.8	0.3	0.15	16	35	74	141	33	44	59	76	1	-1	-4	-8	0.016
17.5	25.5	26.8	0.3	0.15	15	36	80	158	36	50	67	88	1	-1	-4	-8	0.014
17.5	25.5	26.8	0.3	0.15	9.8	20	39	—	12	16	21	—	4	1	-3	—	0.017
17.5	25.5	26.8	0.3	0.15	8.5	20	40	—	13	18	23	—	4	1	-3	—	0.015
17.5	25.5	26.8	0.3	0.15	8.5	20	40	—	13	18	23	—	4	1	-3	—	0.015
17.5	29.5	30.8	0.3	0.15	12	29	66	147	14	20	29	43	3	-1	-7	-16	0.030
17.5	29.5	30.8	0.3	0.15	11	30	72	164	15	23	33	50	3	-1	-7	-16	0.027
17.5	29.5	30.8	0.3	0.15	16	35	103	197	33	43	65	84	1	-1	-6	-11	0.030
17.5	29.5	30.8	0.3	0.15	15	36	114	223	36	49	75	98	1	-1	-6	-11	0.027
17.5	29.5	30.8	0.3	0.15	25	110	234	392	51	85	113	139	0	-5	-10	-15	0.030
17.5	29.5	30.8	0.3	0.15	14	25	53	—	13	16	22	—	3	0	-6	—	0.030
17.5	29.5	30.8	0.3	0.15	13	25	56	—	14	18	25	—	3	0	-6	—	0.027
17.5	29.5	30.8	0.3	0.15	13	25	56	—	14	18	25	—	3	0	-6	—	0.027
20	30	32.5	0.6	0.3	20	40	97	199	17	23	34	48	1	-3	-11	-21	0.045
20	30	32.5	0.6	0.3	20	42	106	224	19	26	39	56	1	-3	-11	-21	0.040
20	30	32.5	0.6	0.3	35	73	197	392									

1. Angular Contact Ball Bearings

Bore Diameter **17, 20mm**

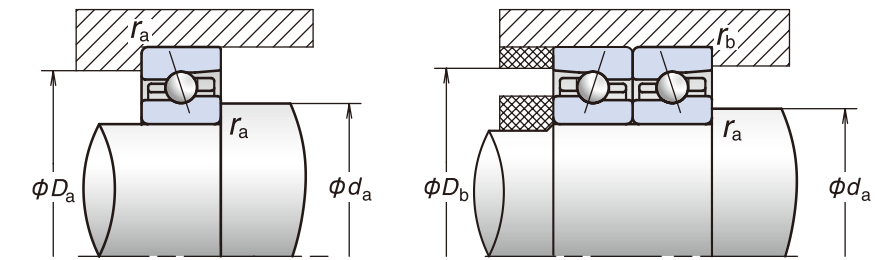
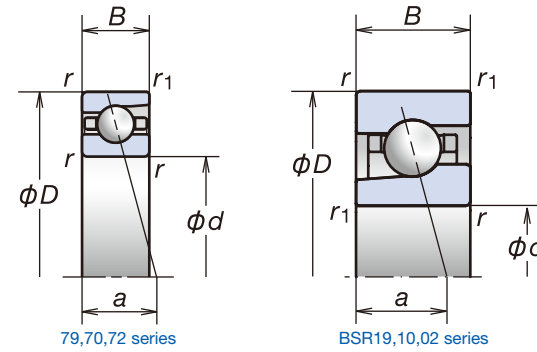

Designation (*)	Boundary Dimensions (mm)					Basic Load Ratings (kN)		Permissible Axial Load (*) (kN)	Contact Angle (°)	Factor f ₀	Effective Load Center (mm) a	Limiting Speeds (°) (min ⁻¹)	
	d	D	B	r (min.)	r ₁ (min.)	C _r (Dynamic)	C _{or} (Static)					Grease	Oil
7903C	17	30	7	0.3	0.15	6.30	2.94	2.09	15	14.8	6.6	49 000	74 500
7903CSN24	17	30	7	0.3	0.15	6.45	2.90	2.46	15	14.8	6.6	63 900	97 100
7903A5	17	30	7	0.3	0.15	6.00	2.80	2.21	25	—	9	42 600	63 900
7903A5SN24	17	30	7	0.3	0.15	6.10	2.76	2.63	25	—	9	55 400	83 000
*17BSR19S	17	30	7	0.3	0.15	4.05	1.53	1.76	15	7.8	6.6	68 100	93 700
*17BSR19H	17	30	7	0.3	0.15	4.05	1.47	1.22	15	7.8	6.6	80 900	120 000
*17BSR19X	17	30	7	0.3	0.15	6.45	1.47	1.22	15	7.8	6.6	93 700	128 000
7003C	17	35	10	0.3	0.15	8.35	3.80	2.85	15	14.5	8.5	44 300	67 400
7003CSN24	17	35	10	0.3	0.15	8.20	3.55	3.38	15	14.5	8.5	57 700	87 700
7003A5	17	35	10	0.3	0.15	7.95	3.65	3.35	25	—	11.1	38 500	57 700
7003A5SN24	17	35	10	0.3	0.15	7.80	3.40	4.00	25	—	11.1	50 000	75 000
7003A	17	35	10	0.3	0.15	7.65	3.50	2.59	30	—	12.5	28 900	38 500
*17BSR10S	17	35	10	0.3	0.15	5.60	1.93	2.39	15	7.4	8.5	61 600	84 700
*17BSR10H	17	35	10	0.3	0.15	5.60	1.85	1.56	15	7.4	8.5	73 100	108 000
*17BSR10X	17	35	10	0.3	0.15	8.90	1.85	1.56	15	7.4	8.5	84 700	116 000
7203C	17	40	12	0.6	0.3	13.7	5.85	4.85	15	13.3	9.8	40 400	61 500
7203CSN24	17	40	12	0.6	0.3	13.6	5.55	5.70	15	13.3	9.8	52 700	80 000
7203A5	17	40	12	0.6	0.3	13.2	5.60	5.30	25	—	12.6	35 100	52 700
7203A5SN24	17	40	12	0.6	0.3	13.1	5.35	6.28	25	—	12.6	45 700	68 500
7203A	17	40	12	0.6	0.3	12.8	5.45	4.05	30	—	14.2	26 400	35 100
*17BSR02S	17	40	12	0.6	0.3	9.15	2.98	3.65	15	6.8	9.8	56 200	77 200
*17BSR02H	17	40	12	0.6	0.3	9.15	2.86	2.39	15	6.8	9.8	66 700	98 300
*17BSR02X	17	40	12	0.6	0.3	14.5	2.86	2.39	15	6.8	9.8	77 200	106 000
7904C	20	37	9	0.3	0.15	8.75	4.25	3.20	15	14.9	8.3	40 400	61 500
7904CSN24	20	37	9	0.3	0.15	8.60	3.95	3.78	15	14.9	8.3	52 700	80 000
7904A5	20	37	9	0.3	0.15	8.30	4.05	3.55	25	—	11.1	35 100	52 700
7904A5SN24	20	37	9	0.3	0.15	8.20	3.80	4.20	25	—	11.1	45 700	68 500
*20BSR19S	20	37	9	0.3	0.15	5.95	2.15	2.66	15	7.7	8.3	56 200	77 200
*20BSR19H	20	37	9	0.3	0.15	5.95	2.05	1.73	15	7.7	8.3	66 700	98 300
*20BSR19X	20	37	9	0.3	0.15	9.40	2.05	1.73	15	7.7	8.3	77 200	106 000
7004C	20	42	12	0.6	0.3	14.0	6.55	4.80	15	14.0	10.1	37 100	56 500
7004CSN24	20	42	12	0.6	0.3	14.1	6.30	5.72	15	14.0	10.1	48 400	73 600
7004A5	20	42	12	0.6	0.3	13.4	6.25	5.45	25	—	13.2	32 300	48 400
7004A5SN24	20	42	12	0.6	0.3	13.5	6.05	6.48	25	—	13.2	42 000	63 000
7004A	20	42	12	0.6	0.3	13.0	6.10	4.20	30	—	14.9	24 200	32 300
*20BSR10S	20	42	12	0.6	0.3	9.40	3.35	4.10	15	7.2	10.1	51 700	71 000
*20BSR10H	20	42	12	0.6	0.3	9.40	3.20	2.67	15	7.2	10.1	61 300	90 400
*20BSR10X	20	42	12	0.6	0.3	14.9	3.20	2.67	15	7.2	10.1	71 000	96 800
7204C	20	47	14	1	0.6	18.3	8.05	6.30	15	13.3	11.5	34 400	52 300
7204CSN24	20	47	14	1	0.6	18.2	7.65	7.46	15	13.3	11.5	44 800	68 100
7204A5	20	47	14	1	0.6	17.6	7.75	7.40	25	—	14.8	29 900	44 800
7204A5SN24	20	47	14	1	0.6	17.5	7.35	8.88	25	—	14.8	38 900	58 300
7204A	20	47	14	1	0.6	17.1	7.55	5.75	30	—	16.7	22 400	29 900
*20BSR02S	20	47	14	1	0.6	12.2	4.10	5.10	15	6.8	11.5	47 800	65 700
*20BSR02H	20	47	14	1	0.6	12.2	3.95	3.30	15	6.8	11.5	56 800	83 600
*20BSR02X	20	47	14	1	0.6	19.4	3.95	3.30	15	6.8	11.5	65 700	89 600

Abutment and Fillet Dimensions (mm)					Preload (DB and DF Arrangement) (N)				Axial Rigidity (DB and DF Arrangement) (N/μm)				Measured Axial Clearance (μm)				Mass (kg) (approx.)
d _a (min.)	D _a (max.)	D _b (max.)	r _a (max.)	r _b (max.)	EL	L	M	H	EL	L	M	H	EL	L	M	H	
19.5	27.5	28.8	0.3	0.15	11	25	56	119	15	21	30	43	3	0	-5	-12	0.017
19.5	27.5	28.8	0.3	0.15	10	25	59	131	16	23	33	49	3	0	-5	-12	0.015
19.5	27.5	28.8	0.3	0.15	15	35	77	149	34	47	63	82	1	-1	-4	-8	0.017
19.5	27.5	28.8	0.3	0.15	14	37	84	167	37	53	72	95	1	-1	-4	-8	0.015
19.5	27.5	28.8	0.3	0.15	12	25	46	—	14	19	24	—	3	0	-4	—	0.018
19.5	27.5	28.8	0.3	0.15	11	25	49	—	13	21	27	—	3	0	-4	—	0.016
19.5	27.5	28.8	0.3	0.15	11	25	49	—	13	21	27	—	3	0	-4	—	0.016
19.5	32.5	33.8	0.3	0.15	15	30	69	156	16	21	31	46	2	-1	-7	-16	0.039
19.5	32.5	33.8	0.3	0.15	15	30	75	174	18	24	35	53	2	-1	-7	-16	0.036
19.5	32.5	33.8	0.3	0.15	25	47	127	257	41	51	74	99	0	-2	-7	-13	0.040
19.5	32.5	33.8	0.3	0.15	25	50	142	293	46	58	86	116	0	-2	-7	-13	0.037
19.5	32.5	33.8	0.3	0.15	25	116	251	422	54	92	123	151	0	-5	-10	-15	0.040
19.5	32.5	33.8	0.3	0.15	13	29	60	—	13	18	24	—	3	-1	-7	—	0.039
19.5	32.5	33.8	0.3	0.15	12	29	65	—	14	20	28	—	3	-1	-7	—	0.036
19.5	32.5	33.8	0.3	0.15	12	29	65	—	14	20	28	—	3	-1	-7	—	0.036
22	35	37.5	0.6	0.3	25	46	146	296	19	25	41	59	0	-4	-16	-28	0.065
22	35	37.5	0.6	0.3	25	49	163	337	21	28	48	69	0	-4	-16	-28	0.058
22	35	37.5	0.6	0.3	35	75	204	408	45	60	87	116	-1	-4	-11	-19	0.064
22	35	37.5	0.6	0.3	37	82	232	470	51	69	102	136	-1	-4	-11	-19	0.057
22	35	37.5	0.6	0.3	25	115	247	412	53	90	119	145	0	-5	-10	-15	0.065
22	35	37.5	0.6	0.3	25	48	97	—	16	21	28	—	0	-5	-13	—	0.065
22	35	37.5	0.6	0.3	25	51	107	—	18	24	32	—	0	-5	-13	—	0.057
22	35	37.5	0.6	0.3	25	51	107	—	18	24	32	—	0	-5	-13	—	0.057
22.5	34.5	35.8	0.3	0.15	20	42	80	152	19	26	35	48	1	-3	-8	-15	0.036
22.5	34.5	35.8	0.3	0.15	19	44	87	169	21	29	40	55	1	-3	-8	-15	0.033
22.5	34.5	35.8	0.3	0.15	25	63	114	247	43	60	75	102	0	-3	-6	-12	0.037
22.5	34.5	35.8	0.3	0.15	25	68	127	282	48	69	87	119	0	-3	-6	-12	0.034
22.5	34.5	35.8	0.3	0.15	16	29	63	—	15	19	26	—	2	-1	-7	—	0.036
22.5	34.5	35.8	0.3	0.15	15	30	67	—	17	21	29	—	2	-1	-7	—	0.033
22.5	34.5	35.8	0.3	0.15	15	30	67	—	17	21	29	—	2	-1	-7	—	0.033
25	37	39.5	0.6	0.3	25	49	119	244	21	28	42	59	0	-4	-12	-22	0.067
25	37	39.5	0.6	0.3	25	52	132	277	24	32	48	68	0	-4	-12	-22	0.060
25	37	39.5	0.6	0.3	36	81	206	403	51	68	97	127	-1	-4	-10	-17	0.067
25	37	39.5	0.6	0.3	38	90	234	465	58	79	113	149	-1	-4	-10	-17	0.060
25	37	39.5	0.6	0.3	25	128	280	473	59	104	139	170	0	-5	-10	-15	0.068
25	37	39.5	0.6	0.3	25	51	107	—	18	24	32	—	0	-5	-13	—	0.068
25	37	39.5	0.6	0.3	25	54	119	—	20	27	37	—	0	-5	-13	—	0.061
25	37	39.5	0.6	0.3	25	54	119	—	20	27	37	—	0	-5	-13	—	0.061
26	41	42	1	0.5	35	68	196	384	23	30	48	68	-2	-7	-20	-33	0.103
26	41	42	1	0.5	37	74	221	440	26	34	56	79	-2	-7	-20	-33	0.091
26	41	42	1	0.5	63	112	290	596	59	73	104	140	-3	-6			

1. Angular Contact Ball Bearings

Bore Diameter **25mm**

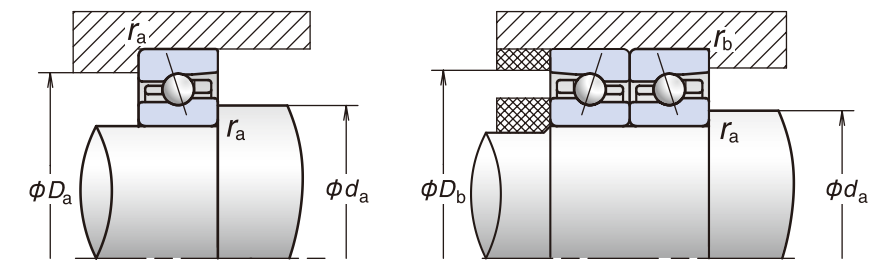
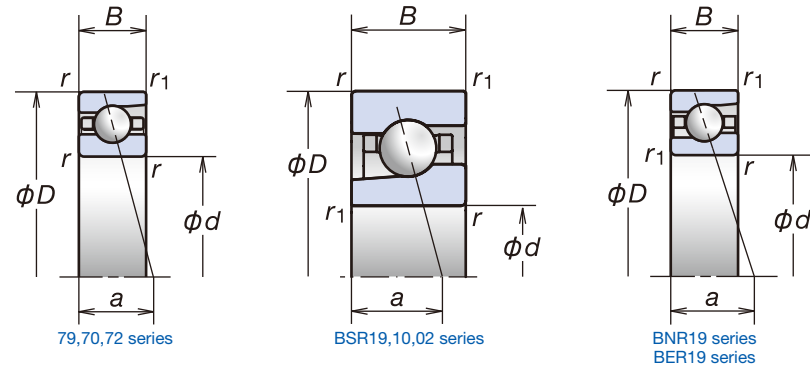

Designation (*)	Boundary Dimensions (mm)					Basic Load Ratings (kN)		Permissible Axial Load (°) (kN)	Contact Angle (°)	Factor f _o	Effective Load Center (mm) a	Limiting Speeds (°) (min ⁻¹)	
	d	D	B	r (min.)	r ₁ (min.)	C _r (Dynamic)	C _{or} (Static)					Grease	Oil
7905C	25	42	9	0.3	0.15	9.90	5.40	3.90	15	15.5	9.0	34 400	52 300
7905CSN24	25	42	9	0.3	0.15	9.75	5.05	4.63	15	15.5	9.0	44 800	68 100
7905A5	25	42	9	0.3	0.15	9.35	5.15	4.40	25	—	12.3	29 900	44 800
7905A5SN24	25	42	9	0.3	0.15	9.20	4.80	5.20	25	—	12.3	38 900	58 300
* 25BSR19S	25	42	9	0.3	0.15	6.75	2.74	3.40	15	7.8	9.0	47 800	65 700
* 25BSR19H	25	42	9	0.3	0.15	6.75	2.62	2.22	15	7.8	9.0	56 800	83 600
* 25BSR19X	25	42	9	0.3	0.15	10.7	2.62	2.22	15	7.8	9.0	65 700	89 600
7005C	25	47	12	0.6	0.3	14.7	7.40	5.20	15	14.7	10.8	32 000	48 700
7005CSN24	25	47	12	0.6	0.3	14.8	7.15	6.16	15	14.7	10.8	41 700	63 400
7005A5	25	47	12	0.6	0.3	14.0	7.10	5.95	25	—	14.4	27 800	41 700
7005A5SN24	25	47	12	0.6	0.3	14.1	6.85	7.08	25	—	14.4	36 200	54 200
7005A	25	47	12	0.6	0.3	13.5	6.85	4.55	30	—	16.4	20 900	27 800
* 25BSR10S	25	47	12	0.6	0.3	9.95	3.75	4.65	15	7.6	10.8	44 500	61 200
* 25BSR10H	25	47	12	0.6	0.3	9.95	3.60	3.05	15	7.6	10.8	52 800	77 800
* 25BSR10X	25	47	12	0.6	0.3	15.8	3.60	3.05	15	7.6	10.8	61 200	83 400
7205C	25	52	15	1	0.6	20.9	10.2	7.50	15	14.0	12.7	29 900	45 500
7205CSN24	25	52	15	1	0.6	20.8	9.70	8.91	15	14.0	12.7	39 000	59 300
7205A5	25	52	15	1	0.6	20.0	9.80	9.05	25	—	16.5	26 000	39 000
7205A5SN24	25	52	15	1	0.6	19.9	9.25	10.7	25	—	16.5	33 800	50 700
7205A	25	52	15	1	0.6	19.4	9.45	6.95	30	—	18.6	19 500	26 000
* 25BSR02S	25	52	15	1	0.6	14.0	5.20	6.45	15	7.1	12.7	41 600	57 200
* 25BSR02H	25	52	15	1	0.6	14.0	4.95	4.20	15	7.1	12.7	49 400	72 800
* 25BSR02X	25	52	15	1	0.6	22.3	4.95	4.20	15	7.1	12.7	57 200	78 000

(*) Bearings denoted by an asterisk (*) are available with seals. Some series are comprised exclusively of sealed bearings.

(°) For details on permissible axial load, refer to Page 199.

(°) For details on limiting speeds, refer to Page 216. See Page 51 for cage differences and their impact on $d_{in}n$ values.

Abutment and Fillet Dimensions (mm)					Preload (DB and DF Arrangement) (N)				Axial Rigidity (DB and DF Arrangement) (N/μm)				Measured Axial Clearance (μm)				Mass (kg) (approx.)
d _a (min.)	D _a (max.)	D _b (max.)	r _a (max.)	r _b (max.)	EL	L	M	H	EL	L	M	H	EL	L	M	H	
27.5	39.5	40.8	0.3	0.15	19	37	99	203	21	28	43	61	1	-2	-9	-17	0.043
27.5	39.5	40.8	0.3	0.15	18	39	109	229	23	31	49	70	1	-2	-9	-17	0.039
27.5	39.5	40.8	0.3	0.15	38	70	153	290	57	71	96	124	-1	-3	-7	-12	0.043
27.5	39.5	40.8	0.3	0.15	39	76	172	332	64	81	111	144	-1	-3	-7	-12	0.039
27.5	39.5	40.8	0.3	0.15	20	41	76	—	18	25	32	—	1	-3	-8	—	0.043
27.5	39.5	40.8	0.3	0.15	19	43	83	—	20	28	36	—	1	-3	-8	—	0.039
27.5	39.5	40.8	0.3	0.15	19	43	83	—	20	28	36	—	1	-3	-8	—	0.039
30	42	44.5	0.6	0.3	30	58	148	292	24	32	48	67	-1	-5	-14	-24	0.078
30	42	44.5	0.6	0.3	31	62	165	332	27	36	55	78	-1	-5	-14	-24	0.070
30	42	44.5	0.6	0.3	52	104	193	397	61	79	100	133	-2	-5	-9	-16	0.077
30	42	44.5	0.6	0.3	55	116	220	458	70	91	116	156	-2	-5	-9	-16	0.069
30	42	44.5	0.6	0.3	25	135	299	507	63	112	149	183	0	-5	-10	-15	0.079
30	42	44.5	0.6	0.3	25	52	112	—	20	25	35	—	0	-5	-13	—	0.078
30	42	44.5	0.6	0.3	25	56	125	—	22	29	40	—	0	-5	-13	—	0.070
30	42	44.5	0.6	0.3	25	56	125	—	22	29	40	—	0	-5	-13	—	0.070
31	46	47	1	0.5	42	82	193	402	27	36	53	76	1	-4	-14	-27	0.127
31	46	47	1	0.5	41	86	212	452	30	41	61	88	1	-4	-14	-27	0.112
31	46	47	1	0.5	82	143	330	691	73	89	123	166	-2	-5	-12	-22	0.130
31	46	47	1	0.5	87	156	372	793	83	103	143	194	-2	-5	-12	-22	0.115
31	46	47	1	0.5	49	357	578	839	80	161	193	223	0	-10	-15	-20	0.129
31	46	47	1	0.5	37	84	163	—	22	31	40	—	2	-5	-14	—	0.127
31	46	47	1	0.5	36	88	179	—	25	35	46	—	2	-5	-14	—	0.112
31	46	47	1	0.5	36	88	179	—	25	35	46	—	2	-5	-14	—	0.112

Calculation of radial rigidity
Multiply axial rigidity by the appropriate factor in Table A.

Calculation of preload and axial rigidity for combined bearings
Multiply by the appropriate factor in Table B. For radial rigidity, multiply the value from Table A with the appropriate factor in Table B.

	EL	L	M	H
15°	6.5	6.0	5.0	4.5
18°		4.5		
25°		2.0		
30°		1.4		

	DBD	DBB
Preload factor	1.36	2
Axial rigidity	1.48	2
Radial rigidity	1.54	2

For additional information:

- Dynamic Equivalent Load ······P191
- Static Equivalent Load ······P198
- Spacer Dimensions and Nozzle Position ···P237
- Recommended Grease Quantities ···P257

1. Angular Contact Ball Bearings

Bore Diameter **30 mm**

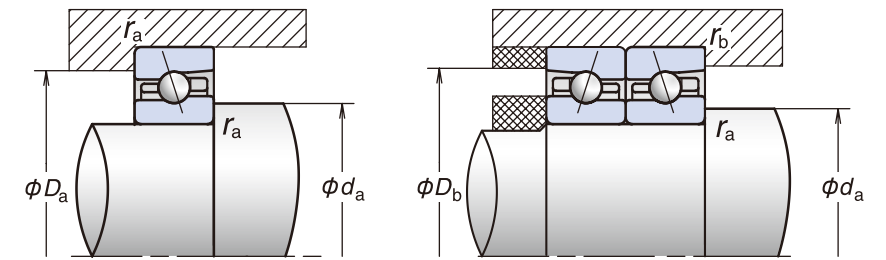
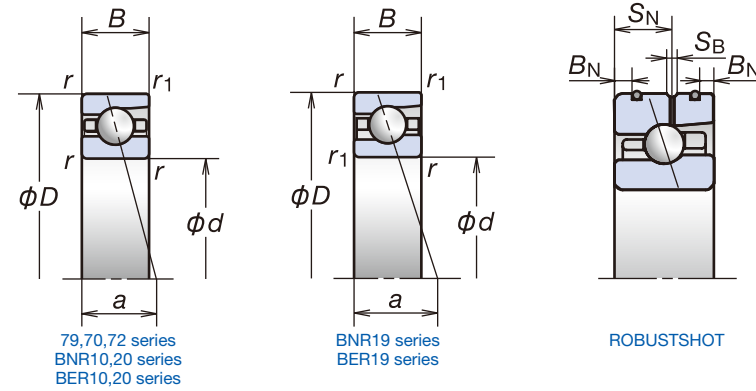

Designation (°)	Boundary Dimensions (°) (mm)						Basic Load Ratings (kN)		Permissible Axial Load (°) (kN)	Contact Angle (°)	Factor fo	Effective Load Center (mm) a	Limiting Speeds (°) (min ⁻¹)			
	d	D	B	BN	SN	SB	r (min.)	r1 (min.)					Cr (Dynamic)	Cor (Static)	Grease	Oil
*7906C	30	47	9	—	—	—	0.3	0.15	10.5	6.25	4.40	15	15.9	9.7	29 900	45 500
*7906CSN24	30	47	9	—	—	—	0.3	0.15	10.3	5.85	5.20	15	15.9	9.7	39 000	59 300
*7906A5	30	47	9	—	—	—	0.3	0.15	9.90	5.95	4.95	25	—	13.5	26 000	39 000
*7906A5SN24	30	47	9	—	—	—	0.3	0.15	9.75	5.55	5.86	25	—	13.5	33 800	50 700
*30BN19BV1V	30	47	9	—	—	—	0.3	0.15	6.35	3.60	5.05	18	10.9	10.8	36 400	—
*30BN19BSN24V1V	30	47	9	—	—	—	0.3	0.15	6.35	3.45	3.30	18	10.9	10.8	46 800	—
*30BA19BV1V	30	47	9	—	—	—	0.3	0.15	6.05	3.45	5.90	25	—	13.5	31 200	—
*30BA19BSN24V1V	30	47	9	—	—	—	0.3	0.15	6.05	3.30	4.00	25	—	13.5	41 600	—
30BNR19S	30	47	9	—	—	—	0.3	0.15	7.90	4.05	5.75	18	10.5	10.8	36 400	52 000
30BNR19H	30	47	9	1.1	5.6	1.4	0.3	0.15	7.90	3.90	3.80	18	10.5	10.8	46 800	72 800
30BNR19X	30	47	9	1.1	5.6	1.4	0.3	0.15	12.6	3.90	3.80	18	10.5	10.8	54 600	85 800
30BER19S	30	47	9	—	—	—	0.3	0.15	7.60	3.90	6.80	25	—	13.5	31 200	44 200
30BER19H	30	47	9	1.1	5.6	1.4	0.3	0.15	7.60	3.75	4.60	25	—	13.5	41 600	65 000
30BER19X	30	47	9	1.1	5.6	1.4	0.3	0.15	12.0	3.75	4.60	25	—	13.5	49 400	78 000
*7006C	30	55	13	—	—	—	1	0.6	19.1	10.3	6.85	15	14.9	12.2	27 100	41 200
*7006CSN24	30	55	13	—	—	—	1	0.6	19.4	10.0	8.12	15	14.9	12.2	35 300	53 700
*7006A5	30	55	13	—	—	—	1	0.6	18.2	9.80	8.05	25	—	16.4	23 600	35 300
*7006A5SN24	30	55	13	—	—	—	1	0.6	18.4	9.55	9.56	25	—	16.4	30 600	45 900
*7006A	30	55	13	—	—	—	1	0.6	17.5	9.45	6.20	30	—	18.8	17 700	23 600
*30BNR10S	30	55	13	—	—	—	1	0.6	10.9	5.75	8.20	18	10.3	13.3	33 000	47 100
*30BNR10H	30	55	13	2.8	7.5	1.4	1	0.6	10.9	5.50	5.35	18	10.3	13.3	42 400	65 900
*30BNR10X	30	55	13	2.8	7.5	1.4	1	0.6	17.3	5.50	5.35	18	10.3	13.3	49 500	77 700
*30BER10S	30	55	13	—	—	—	1	0.6	10.5	5.50	9.65	25	—	16.3	28 300	40 000
*30BER10H	30	55	13	2.8	7.5	1.4	1	0.6	10.5	5.30	6.50	25	—	16.3	37 700	58 900
*30BER10X	30	55	13	2.8	7.5	1.4	1	0.6	16.6	5.30	6.50	25	—	16.3	44 800	70 600
*30BNR20SV1V	30	55	16	—	—	—	1	0.6	10.9	5.75	8.20	18	10.3	14.8	33 000	—
*30BNR20HV1V	30	55	16	—	—	—	1	0.6	10.9	5.50	5.35	18	10.3	14.8	42 400	—
*30BNR20XV1V	30	55	16	—	—	—	1	0.6	17.3	5.50	5.35	18	10.3	14.8	49 500	—
*30BER20SV1V	30	55	16	—	—	—	1	0.6	10.5	5.50	9.65	25	—	17.8	28 300	—
*30BER20HV1V	30	55	16	—	—	—	1	0.6	10.5	5.30	6.50	25	—	17.8	37 700	—
*30BER20XV1V	30	55	16	—	—	—	1	0.6	16.6	5.30	6.50	25	—	17.8	44 800	—
7206C	30	62	16	—	—	—	1	0.6	29.0	14.7	10.3	15	13.9	14.2	25 000	38 100
7206CSN24	30	62	16	—	—	—	1	0.6	29.2	14.2	12.2	15	13.9	14.2	32 700	49 600
7206A5	30	62	16	—	—	—	1	0.6	27.8	14.1	12.0	25	—	18.7	21 800	32 700
7206A5SN24	30	62	16	—	—	—	1	0.6	27.9	13.6	14.2	25	—	18.7	28 300	42 400
7206A	30	62	16	—	—	—	1	0.6	26.9	13.6	9.20	30	—	21.3	16 400	21 800

Abutment and Fillet Dimensions (mm)					Preload (DB and DF Arrangement) (N)				Axial Rigidity (DB and DF Arrangement) (N/μm)				Measured Axial Clearance (μm)				Mass (kg) (approx.)
da (min.)	Da (max.)	Db (max.)	ra (max.)	rb (max.)	EL	L	M	H	EL	L	M	H	EL	L	M	H	
32.5	44.5	45.8	0.3	0.15	25	46	95	204	25	33	45	65	0	-3	-8	-16	0.049
32.5	44.5	45.8	0.3	0.15	25	49	104	230	28	37	51	75	0	-3	-8	-16	0.044
32.5	44.5	45.8	0.3	0.15	39	74	141	285	62	78	99	131	-1	-3	-6	-11	0.050
32.5	44.5	45.8	0.3	0.15	41	81	158	326	70	90	115	154	-1	-3	-6	-11	0.045
32.5	44.5	45.8	0.3	0.15	25	109	218	—	30	53	71	—	0	-8	-15	—	0.050
32.5	44.5	45.8	0.3	0.15	25	121	248	—	34	62	83	—	0	-8	-15	—	0.047
32.5	44.5	45.8	0.3	0.15	25	178	352	—	50	100	131	—	0	-8	-14	—	0.050
32.5	44.5	45.8	0.3	0.15	25	202	405	—	56	117	153	—	0	-8	-14	—	0.047
32.5	44.5	45.8	0.3	0.15	25	101	197	—	28	48	63	—	0	-8	-15	—	0.048
32.5	44.5	45.8	0.3	0.15	25	112	224	—	31	55	73	—	0	-8	-15	—	0.043
32.5	44.5	45.8	0.3	0.15	25	112	224	—	31	55	73	—	0	-8	-15	—	0.043
32.5	44.5	45.8	0.3	0.15	25	164	318	—	47	90	116	—	0	-8	-14	—	0.048
32.5	44.5	45.8	0.3	0.15	25	185	366	—	52	105	136	—	0	-8	-14	—	0.043
32.5	44.5	45.8	0.3	0.15	25	185	366	—	52	105	136	—	0	-8	-14	—	0.043
36	49	50	1	0.5	41	75	195	386	30	38	58	81	1	-3	-13	-24	0.114
36	49	50	1	0.5	41	78	214	434	33	42	66	94	1	-3	-13	-24	0.102
36	49	50	1	0.5	66	129	294	590	73	93	127	169	-1	-4	-10	-18	0.114
36	49	50	1	0.5	68	139	331	676	82	106	148	197	-1	-4	-10	-18	0.102
36	49	50	1	0.5	49	191	390	638	87	138	180	217	0	-5	-10	-15	0.116
36	49	50	1	0.5	49	106	229	—	39	52	71	—	0	-5	-13	—	0.124
36	49	50	1	0.5	49	113	254	—	44	59	82	—	0	-5	-13	—	0.116
36	49	50	1	0.5	49	113	254	—	44	59	82	—	0	-5	-13	—	0.116
36	49	50	1	0.5	49	224	443	—	64	109	141	—	0	-8	-15	—	0.124
36	49	50	1	0.5	49	250	505	—	72	126	165	—	0	-8	-15	—	0.116
36	49	50	1	0.5	49	250	505	—	72	126	165	—	0	-8	-15	—	0.116
36	49	50	1	0.5	49	106	229	—	39	52	71	—	0	-5	-13	—	0.150
36	49	50	1	0.5	49	113	254	—	44	59	82	—	0	-5	-13	—	0.142
36	49	50	1	0.5	49	113	254	—	44	59	82	—	0	-5	-13	—	0.142
36	49	50	1	0.5	49	224	443	—	64	109	141	—	0	-8	-15	—	0.150
36	49	50	1	0.5	49	250	505	—	72	126	165	—	0	-8	-15	—	0.142
36	49	50	1	0.5	49	250	505	—	72	126	165	—	0	-8	-15	—	0.142
36	56	57	1	0.5	57	114	292	591	33	43	66	94	-1	-7	-20	-35	0.194
36	56	57	1	0.5	58	122	326	673	36	49	76	109	-1	-7	-20	-35	0.169
36	56	57	1	0.5	105	202	457	881	85	108	147	192	-3	-7	-15	-25	0.194
36	56	57	1	0.5	113	224	521	1 018	97	124	172	225	-3	-7	-15	-25	0.169
36	56	57	1	0.5	49	384	625	908	86	175	210	243	0	-10	-15	-20	0.197

(°) Bearings denoted by an asterisk (*) are available with seals. Series 20 is comprised exclusively of sealed bearings.
 (°) ROBUSTSHOT bearings are available for designations with values in the BN, SN, and SB columns.
 (°) For details on permissible axial load, refer to Page 199.
 (°) For details on limiting speeds, refer to Page 216. See Page 51 for cage differences and their impact on d_m values.

Calculation of radial rigidity
 Multiply axial rigidity by the appropriate factor in Table A.
Calculation of preload and axial rigidity for combined bearings
 Multiply by the appropriate factor in Table B. For radial rigidity, multiply the value from Table A with the appropriate factor in Table B.

Table A	EL	L	M	H
15°	6.5	6.0	5.0	4.5
18°			4.5	
25°			2.0	
30°			1.4	

Table B	DBD	DBB
Preload factor	1.36	2
Axial rigidity	1.48	2
Radial rigidity	1.54	2

For additional information:
 ● Dynamic Equivalent Load ······P191
 ● Static Equivalent Load ······P198
 ● Spacer Dimensions and Nozzle Position ···P237
 ● Recommended Grease Quantities ···P257

1. Angular Contact Ball Bearings

Bore Diameter **35 mm**

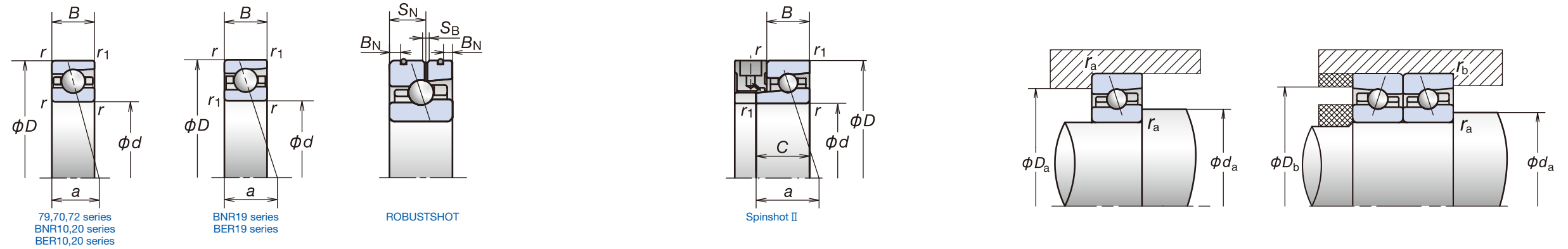

Designation (*)	Boundary Dimensions (°) (mm)									Basic Load Ratings (kN)		Permissible Axial Load (°) (kN)	Contact Angle (°)	Factor f_o	Effective Load Center (mm) a	Limiting Speeds (°) (min ⁻¹)	
	d	D	B	C	B_N	S_N	S_B	r (min.)	r_1 (min.)	C_r (Dynamic)	C_{or} (Static)					Grease	Oil
*7907C	35	55	10	—	—	—	—	0.6	0.3	15.2	9.15	6.60	15	15.7	11.0	25 600	38 900
*7907CSN24	35	55	10	—	—	—	—	0.6	0.3	15.0	8.55	7.82	15	15.7	11.0	33 400	50 700
*7907A5	35	55	10	—	—	—	—	0.6	0.3	14.4	8.70	7.20	25	—	15.5	22 300	33 400
*7907A5SN24	35	55	10	—	—	—	—	0.6	0.3	14.2	8.15	8.52	25	—	15.5	28 900	43 400
*35BN19AV1V	35	55	10	—	—	—	—	0.6	0.3	8.80	5.10	7.20	18	10.8	12.3	31 200	—
*35BN19ASN24V1V	35	55	10	—	—	—	—	0.6	0.3	8.80	4.90	4.75	18	10.8	12.3	40 000	—
*35BA19BV1V	35	55	10	—	—	—	—	0.6	0.3	8.40	4.90	8.50	25	—	15.5	26 700	—
*35BA19BSN24V1V	35	55	10	—	—	—	—	0.6	0.3	8.40	4.70	5.75	25	—	15.5	35 600	—
35BNR19S	35	55	10	—	—	—	—	0.6	0.3	11.6	6.00	8.55	18	10.4	12.3	31 200	44 500
35BNR19H	35	55	10	—	1.6	6.1	1.4	0.6	0.3	11.6	5.70	5.60	18	10.4	12.3	40 000	62 300
35BNR19X	35	55	10	15	1.6	6.1	1.4	0.6	0.3	18.4	5.70	5.60	18	10.4	12.3	46 700	73 400
35BER19S	35	55	10	—	—	—	—	0.6	0.3	11.1	5.75	10.0	25	—	15.5	26 700	37 800
35BER19H	35	55	10	—	1.6	6.1	1.4	0.6	0.3	11.1	5.50	6.80	25	—	15.5	35 600	55 600
35BER19X	35	55	10	15	1.6	6.1	1.4	0.6	0.3	17.6	5.50	6.80	25	—	15.5	42 300	66 700
*7007C	35	62	14	—	—	—	—	1	0.6	24.1	13.7	9.35	15	15.0	13.5	23 800	36 100
*7007CSN24	35	62	14	—	—	—	—	1	0.6	24.0	13.0	11.1	15	15.0	13.5	29 700	45 200
*7007A5	35	62	14	—	—	—	—	1	0.6	22.9	13.0	11.4	25	—	18.3	20 700	31 000
*7007A5SN24	35	62	14	—	—	—	—	1	0.6	22.8	12.4	13.5	25	—	18.3	25 800	38 800
*7007A	35	62	14	—	—	—	—	1	0.6	22.1	12.6	8.75	30	—	21.0	15 500	20 700
*35BNR10S	35	62	14	—	—	—	—	1	0.6	12.8	7.10	10.2	18	10.6	14.8	28 900	41 300
*35BNR10H	35	62	14	—	2.8	8.3	1.4	1	0.6	12.8	6.80	6.70	18	10.6	14.8	37 200	57 800
*35BNR10X	35	62	14	19	2.8	8.3	1.4	1	0.6	20.3	6.80	6.70	18	10.6	14.8	43 300	68 100
*35BER10S	35	62	14	—	—	—	—	1	0.6	12.2	6.85	12.0	25	—	18.2	24 800	35 100
*35BER10H	35	62	14	—	2.8	8.3	1.4	1	0.6	12.2	6.55	8.10	25	—	18.2	33 000	51 600
*35BER10X	35	62	14	19	2.8	8.3	1.4	1	0.6	19.4	6.55	8.10	25	—	18.2	39 200	61 900
*35BNR20SV1V	35	62	17	—	—	—	—	1	0.6	12.8	7.10	10.2	18	10.6	16.3	28 900	—
*35BNR20HV1V	35	62	17	—	—	—	—	1	0.6	12.8	6.80	6.70	18	10.6	16.3	37 200	—
*35BNR20XV1V	35	62	17	—	—	—	—	1	0.6	20.3	6.80	6.70	18	10.6	16.3	43 300	—
*35BER20SV1V	35	62	17	—	—	—	—	1	0.6	12.2	6.85	12.0	25	—	19.7	24 800	—
*35BER20HV1V	35	62	17	—	—	—	—	1	0.6	12.2	6.55	8.10	25	—	19.7	33 000	—
*35BER20XV1V	35	62	17	—	—	—	—	1	0.6	19.4	6.55	8.10	25	—	19.7	39 200	—
7207C	35	72	17	—	—	—	—	1.1	0.6	38.5	19.9	14.4	15	13.9	15.7	21 500	32 800
7207CSN24	35	72	17	—	—	—	—	1.1	0.6	38.0	19.0	17.1	15	13.9	15.7	28 100	42 700
7207A5	35	72	17	—	—	—	—	1.1	0.6	36.5	19.1	16.6	25	—	21.0	18 700	28 100
7207A5SN24	35	72	17	—	—	—	—	1.1	0.6	36.5	18.2	19.7	25	—	21.0	24 300	36 500
7207A	35	72	17	—	—	—	—	1.1	0.6	35.5	18.5	12.7	30	—	23.9	14 100	18 700

Abutment and Fillet Dimensions (mm)					Preload (DB and DF Arrangement) (N)				Axial Rigidity (DB and DF Arrangement) (N/μm)				Measured Axial Clearance (μm)				Mass (kg) (approx.)
d_a (min.)	D_a (max.)	D_b (max.)	r_a (max.)	r_b (max.)	EL	L	M	H	EL	L	M	H	EL	L	M	H	
40	50	52.5	0.6	0.3	33	67	149	297	29	39	55	77	2	-2	-9	-18	0.074
40	50	52.5	0.6	0.3	32	69	162	332	32	43	63	89	2	-2	-9	-18	0.065
40	50	52.5	0.6	0.3	49	110	248	508	70	93	127	169	0	-3	-8	-15	0.075
40	50	52.5	0.6	0.3	49	119	278	580	79	107	147	198	0	-3	-8	-15	0.066
40	50	52.5	0.6	0.3	49	154	324	—	41	64	87	—	0	-8	-17	—	0.080
40	50	52.5	0.6	0.3	49	168	364	—	46	73	101	—	0	-8	-17	—	0.074
40	50	52.5	0.6	0.3	49	235	472	—	67	117	153	—	0	-8	-15	—	0.080
40	50	52.5	0.6	0.3	49	263	538	—	75	135	178	—	0	-8	-15	—	0.074
40	50	52.5	0.6	0.3	49	142	288	—	37	56	74	—	0	-8	-17	—	0.072
40	50	52.5	0.6	0.3	49	155	323	—	42	64	86	—	0	-8	-17	—	0.063
40	50	52.5	0.6	0.3	49	155	323	—	42	64	86	—	0	-8	-17	—	0.063
40	50	52.5	0.6	0.3	49	214	419	—	61	102	132	—	0	-8	-15	—	0.072
40	50	52.5	0.6	0.3	49	238	477	—	68	118	154	—	0	-8	-15	—	0.063
40	50	52.5	0.6	0.3	49	238	477	—	68	118	154	—	0	-8	-15	—	0.063
41	56	57	1	0.5	58	121	251	493	36	49	67	94	-1	-7	-16	-28	0.151
41	56	57	1	0.5	59	130	279	558	40	55	78	109	-1	-7	-16	-28	0.133
41	56	57	1	0.5	68	161	387	779	78	107	150	199	-1	-5	-12	-21	0.151
41	56	57	1	0.5	70	177	439	897	89	124	174	233	-1	-5	-12	-21	0.133
41	56	57	1	0.5	49	203	421	693	93	151	197	237	0	-5	-10	-15	0.153
41	56	57	1	0.5	49	110	222	—	41	55	73	—	0	-5	-12	—	0.164
41	56	57	1	0.5	49	117	247	—	46	63	85	—	0	-5	-12	—	0.154
41	56	57	1	0.5	49	117	247	—	46	63	85	—	0	-5	-12	—	0.154
41	56	57	1	0.5	49	237	474	—	68	118	153	—	0	-8	-15	—	0.164
41	56	57	1	0.5	49	265	541	—	76	136	178	—	0	-8	-15	—	0.154
41	56	57	1	0.5	49	265	541	—	76	136	178	—	0	-8	-15	—	0.154
41	56	57	1	0.5	49	110	222	—	41	55	73	—	0	-5	-12	—	0.197
41	56	57	1	0.5	49	117	247	—	46	63	85	—	0	-5	-12	—	0.187
41	56	57	1	0.5	49	117	247	—	46	63	85	—	0	-5	-12	—	0.187
41	56	57	1	0.5	49	237	474	—	68	118	153	—	0	-8	-15	—	0.197
41	56	57	1	0.5	49	265	541	—	76	136	178	—	0	-8	-15	—	0.187
41	56	57	1	0.5	49	265	541	—	76	136	178	—	0	-8	-15	—	0.187
42	65	67	1	0.6	75	151	385	794	37	50	75	107	-3	-10	-25	-43	0.280
42	65	67	1	0.6	78	164	434	911	42	57	87	125	-3	-10	-25	-43	0.240
42	65	67	1	0.6	131	238	596	1 178	95	118	167	220	-4	-8	-18	-30	0.277
42	65	67	1	0.6	142	266	683	1 366	109	137	196	259	-4	-8	-18	-30	0.237
42	65	67	1	0.6	49	401	654	1 288	90	184	221	286	0	-10	-15	-25	0.284

(*) Bearings denoted by an asterisk (*) are available with seals. Series 20 is comprised exclusively of sealed bearings.
 (°) Spinslot II bearings are available for designations with values in the C column, and ROBUSTSHOT bearings are available for designations with values in the B_N , S_N , and S_B columns.
 (°) For details on permissible axial load, refer to Page 199.
 (°) For details on limiting speeds, refer to Page 216. See Page 51 for cage differences and their impact on $d_{gr}n$ values.

Calculation of radial rigidity
 Multiply axial rigidity by the appropriate factor in Table A.

Table A	EL	L	M	H
15°	6.5	6.0	5.0	4.5
18°			4.5	
25°			2.0	
30°			1.4	

Calculation of preload and axial rigidity for combined bearings
 Multiply by the appropriate factor in Table B. For radial rigidity, multiply the value from Table A with the appropriate factor in Table B.

Table B	DBD	DBB
Preload factor	1.36	2
Axial rigidity	1.48	2
Radial rigidity	1.54	2

For additional information:

- Dynamic Equivalent Load ······P191
- Static Equivalent Load ······P198
- Spacer Dimensions and Nozzle Position ···P237
- Recommended Grease Quantities ···P257

1. Angular Contact Ball Bearings

Bore Diameter **40mm**

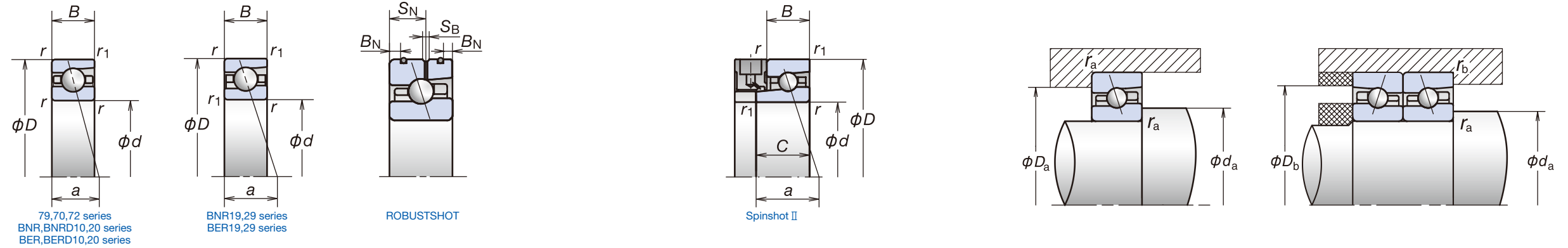

Designation (*)	Boundary Dimensions (°) (mm)							Basic Load Ratings (kN)		Permissible Axial Load (°) (kN)	Contact Angle (°)	Factor f_o	Effective Load Center (mm) a	Limiting Speeds (°) (min ⁻¹)			
	d	D	B	C	B_N	S_N	S_B	r (min.)	r_1 (min.)					C_r (Dynamic)	C_{or} (Static)	Grease	Oil
*7908C	40	62	12	—	—	—	—	0.6	0.3	19.1	11.7	8.40	15	15.7	12.8	29 500	44 800
*7908CSN24	40	62	12	—	—	—	—	0.6	0.3	19.0	11.2	9.97	15	15.7	12.8	29 500	44 800
*7908A5	40	62	12	—	—	—	—	0.6	0.3	18.1	11.2	8.90	25	—	17.9	19 700	29 500
*7908A5SN24	40	62	12	—	—	—	—	0.6	0.3	18.0	10.6	10.5	25	—	17.9	25 500	38 300
*40BNR19S	40	62	12	—	—	—	—	0.6	0.3	14.5	7.65	10.8	18	10.4	14.3	27 500	39 300
*40BNR19H	40	62	12	—	2.2	7.0	1.4	0.6	0.3	14.5	7.30	7.10	18	10.4	14.3	35 300	55 000
*40BNR19X	40	62	12	17	2.2	7.0	1.4	0.6	0.3	22.9	7.30	7.10	18	10.4	14.3	41 200	64 800
*40BER19S	40	62	12	—	—	—	—	0.6	0.3	13.9	7.35	12.8	25	—	17.9	23 600	33 400
*40BER19H	40	62	12	—	2.2	7.0	1.4	0.6	0.3	13.9	7.05	8.65	25	—	17.9	31 400	49 100
*40BER19X	40	62	12	17	2.2	7.0	1.4	0.6	0.3	22.0	7.05	8.65	25	—	17.9	37 300	58 900
*40BNR29SV1V	40	62	14	—	—	—	—	0.6	0.3	14.5	7.65	10.8	18	10.4	15.3	27 500	—
*40BNR29HV1V	40	62	14	—	—	—	—	0.6	0.3	14.5	7.30	7.10	18	10.4	15.3	35 300	—
*40BNR29XV1V	40	62	14	—	—	—	—	0.6	0.3	22.9	7.30	7.10	18	10.4	15.3	41 200	—
*40BER29SV1V	40	62	14	—	—	—	—	0.6	0.3	13.9	7.35	12.8	25	—	18.9	23 600	—
*40BER29HV1V	40	62	14	—	—	—	—	0.6	0.3	13.9	7.05	8.65	25	—	18.9	31 400	—
*40BER29XV1V	40	62	14	—	—	—	—	0.6	0.3	22.0	7.05	8.65	25	—	18.9	37 300	—
*7008C	40	68	15	—	—	—	—	1	0.6	25.9	15.9	10.6	15	15.4	14.7	21 300	32 500
*7008CSN24	40	68	15	—	—	—	—	1	0.6	25.8	15.1	12.5	15	15.4	14.7	27 800	42 300
*7008A5	40	68	15	—	—	—	—	1	0.6	24.6	15.1	12.0	25	—	20.1	18 600	27 800
*7008A5SN24	40	68	15	—	—	—	—	1	0.6	24.4	14.3	14.2	25	—	20.1	24 100	36 200
*7008A	40	68	15	—	—	—	—	1	0.6	23.7	14.6	9.15	30	—	23.1	13 900	18 600
*40BNR10S	40	68	15	—	—	—	—	1	0.6	13.3	7.95	11.5	18	10.7	16.2	26 000	37 100
*40BNR10H	40	68	15	—	2.8	8.8	1.4	1	0.6	13.3	7.60	7.50	18	10.7	16.2	33 400	51 900
*40BNR10X	40	68	15	20	2.8	8.8	1.4	1	0.6	21.2	7.60	7.50	18	10.7	16.2	38 900	61 200
*40BER10S	40	68	15	—	—	—	—	1	0.6	12.8	7.65	13.5	25	—	19.9	22 300	31 500
*40BER10H	40	68	15	—	2.8	8.8	1.4	1	0.6	12.8	7.30	9.10	25	—	19.9	29 700	46 300
*40BER10X	40	68	15	20	2.8	8.8	1.4	1	0.6	20.3	7.30	9.10	25	—	19.9	35 200	55 600
*40BNRD10J	40	68	15	—	2.8	8.8	1.4	1	0.6	22.6	8.00	7.70	18	7.9	16.3	33 400	51 900
*40BNRD10X	40	68	15	20	2.8	8.8	1.4	1	0.6	28.5	8.00	7.70	18	7.9	16.3	38 900	61 200
*40BERD10J	40	68	15	—	2.8	8.8	1.4	1	0.6	21.8	7.70	9.45	25	—	20.1	29 700	46 300
*40BERD10X	40	68	15	20	2.8	8.8	1.4	1	0.6	27.4	7.70	9.45	25	—	20.1	35 200	55 600
*40BNR20SV1V	40	68	18	—	—	—	—	1	0.6	13.3	7.95	11.5	18	10.7	17.7	26 000	—
*40BNR20HV1V	40	68	18	—	—	—	—	1	0.6	13.3	7.60	7.50	18	10.7	17.7	33 400	—
*40BNR20XV1V	40	68	18	—	—	—	—	1	0.6	21.2	7.60	7.50	18	10.7	17.7	38 900	—
*40BER20SV1V	40	68	18	—	—	—	—	1	0.6	12.8	7.65	13.5	25	—	21.4	22 300	—
*40BER20HV1V	40	68	18	—	—	—	—	1	0.6	12.8	7.30	9.10	25	—	21.4	29 700	—
*40BER20XV1V	40	68	18	—	—	—	—	1	0.6	20.3	7.30	9.10	25	—	21.4	35 200	—
7208C	40	80	18	—	—	—	—	1.1	0.6	46.0	25.2	17.6	15	14.1	17.0	19 200	29 200
7208CSN24	40	80	18	—	—	—	—	1.1	0.6	46.0	24.2	20.9	15	14.1	17.0	25 000	38 000
7208A5	40	80	18	—	—	—	—	1.1	0.6	44.0	24.1	20.6	25	—	23.0	16 700	25 000
7208A5SN24	40	80	18	—	—	—	—	1.1	0.6	44.0	23.1	24.4	25	—	23.0	21 700	32 500
7208A	40	80	18	—	—	—	—	1.1	0.6	42.5	23.4	15.8	30	—	26.3	12 500	16 700

Abutment and Fillet Dimensions (mm)					Preload (DB and DF Arrangement) (N)				Axial Rigidity (DB and DF Arrangement) (N/μm)				Measured Axial Clearance (μm)				Mass (kg) (approx.)
d_a (min.)	D_a (max.)	D_b (max.)	r_a (max.)	r_b (max.)	EL	L	M	H	EL	L	M	H	EL	L	M	H	
45	57	59.5	0.6	0.3	41	78	196	384	32	42	63	88	1	—3	—12	—22	0.109
45	57	59.5	0.6	0.3	40	81	215	432	35	47	72	101	1	—3	—12	—22	0.096
45	57	59.5	0.6	0.3	68	113	291	572	81	97	139	182	—1	—3	—9	—16	0.110
45	57	59.5	0.6	0.3	71	121	327	655	92	111	161	213	—1	—3	—9	—16	0.097
45	57	59.5	0.6	0.3	49	145	277	—	38	57	74	—	0	—8	—16	—	0.105
45	57	59.5	0.6	0.3	49	158	310	—	43	66	86	—	0	—8	—16	—	0.092
45	57	59.5	0.6	0.3	49	158	310	—	43	66	86	—	0	—8	—16	—	0.092
45	57	59.5	0.6	0.3	49	221	434	—	63	106	137	—	0	—8	—15	—	0.105
45	57	59.5	0.6	0.3	49	246	494	—	71	123	160	—	0	—8	—15	—	0.092
45	57	59.5	0.6	0.3	49	246	494	—	71	123	160	—	0	—8	—15	—	0.092
45	57	59.5	0.6	0.3	49	145	277	—	38	57	74	—	0	—8	—16	—	0.120
45	57	59.5	0.6	0.3	49	158	310	—	43	66	86	—	0	—8	—16	—	0.107
45	57	59.5	0.6	0.3	49	158	310	—	43	66	86	—	0	—8	—16	—	0.107
45	57	59.5	0.6	0.3	49	221	434	—	63	106	137	—	0	—8	—15	—	0.120
45	57	59.5	0.6	0.3	49	246	494	—	71	123	160	—	0	—8	—15	—	0.107
45	57	59.5	0.6	0.3	49	246	494	—	71	123	160	—	0	—8	—15	—	0.107
46	62	63	1	0.5	58	114	291	594	39	51	77	110	—1	—6	—17	—30	0.189
46	62	63	1	0.5	59	123	325	676	43	58	89	128	—1	—6	—17	—30	0.168
46	62	63	1	0.5	92	203	424	864	95	127	167	223	—2	—6	—12	—21	0.188
46	62	63	1	0.5	98	225	483	998	108	147	195	262	—2	—6	—12	—21	0.167
46	62	63	1	0.5	49	219	463	768	101	168	221	267	0	—5	—10	—15	0.191
46	62	63	1	0.5	49	114	216	—	44	60	77	—	0	—5	—11	—	0.204
46	62	63	1	0.5	49	122	240	—	49	68	89	—	0	—5	—11	—	0.193
46	62	63	1	0.5	49	122	240	—	49	68	89	—	0	—5	—11	—	0.193
46	62	63	1	0.5	49	252	510	—	72	128	167	—	0	—8	—15	—	0.204
46	62	63	1	0.5	49	282	583	—	81	148	195	—	0	—8	—15	—	0.193
46	62	63	1	0.5	49	282	583	—	81	148	195	—	0	—8	—15	—	0.193
46	62	63	1	0.5	49	148	304	—	45	67	88	—	0	—7	—15	—	0.173
46	62	63	1	0.5	49	148	304	—	45	67	88	—	0	—7	—15	—	0.173
46	62	63	1	0.5	49	197	405	—	74	120	156	—	0	—6	—12	—	0.173
46	62	63	1	0.5	49	197	405	—	74	120	156	—	0	—6	—12	—	0.173
46	62	63	1	0.5	49	114	216	—	44	60	77	—	0	—5	—11	—	0.242
46	62	63	1	0.5	49	122	240	—	49	68	89	—	0	—5	—11	—	0.231
46	62	63	1	0.5	49	122	240	—	49	68	89	—	0	—5	—11	—	0.231
46	62	63	1	0.5	49	252	510	—	72	128	167	—	0	—8	—15	—	0.242
46	62	63	1	0.5	49	282	583	—	81	148	195	—	0	—8	—15	—	0.231
46	62	63	1	0.5	49	282	583	—	81	148	195	—	0	—8	—15	—	0.231
47	73	75															

1. Angular Contact Ball Bearings

Bore Diameter **45mm**

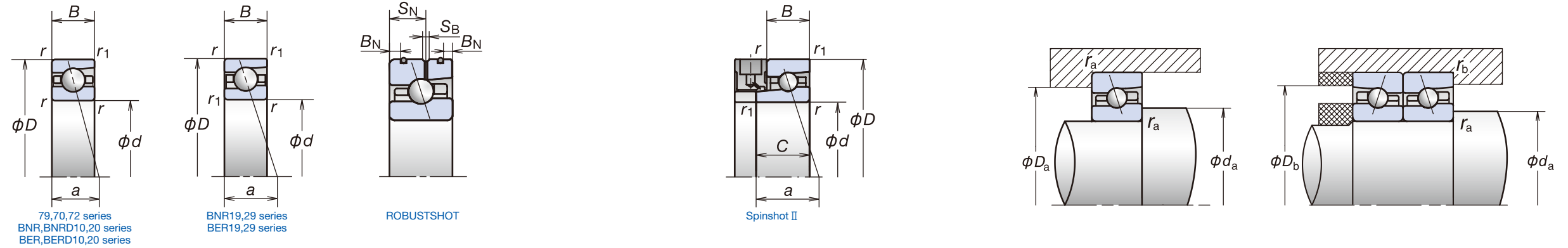

Designation (*)	Boundary Dimensions (°) (mm)							Basic Load Ratings (kN)		Permissible Axial Load (°) (kN)	Contact Angle (°)	Factor f_o	Effective Load Center (mm) a	Limiting Speeds (°) (min ⁻¹)			
	d	D	B	C	B_N	S_N	S_B	r (min.)	r_1 (min.)					C_r (Dynamic)	C_{or} (Static)	Grease	Oil
*7909C	45	68	12	—	—	—	—	0.6	0.3	20.2	13.4	8.55	15	16.0	13.6	20 400	31 000
*7909CSN24	45	68	12	—	—	—	—	0.6	0.3	20.1	12.7	10.1	15	16.0	13.6	26 600	40 400
*7909A5	45	68	12	—	—	—	—	0.6	0.3	19.1	12.7	9.95	25	—	19.2	17 700	26 600
*7909A5SN24	45	68	12	—	—	—	—	0.6	0.3	19.0	12.1	11.8	25	—	19.2	23 100	34 600
*45BNR19S	45	68	12	—	—	—	—	0.6	0.3	15.3	8.70	12.4	18	10.6	15.2	24 800	35 400
*45BNR19H	45	68	12	—	2.2	7.0	1.4	0.6	0.3	15.3	8.30	8.10	18	10.6	15.2	31 900	49 600
*45BNR19X	45	68	12	17	2.2	7.0	1.4	0.6	0.3	24.3	8.30	8.10	18	10.6	15.2	37 200	58 500
*45BER19S	45	68	12	—	—	—	—	0.6	0.3	14.7	8.35	14.6	25	—	19.2	21 300	30 100
*45BER19H	45	68	12	—	2.2	7.0	1.4	0.6	0.3	14.7	8.00	9.85	25	—	19.2	28 400	44 300
*45BER19X	45	68	12	17	2.2	7.0	1.4	0.6	0.3	23.3	8.00	9.85	25	—	19.2	33 700	53 100
*45BNR29SV1V	45	68	14	—	—	—	—	0.6	0.3	15.3	8.70	12.4	18	10.6	16.2	24 800	—
*45BNR29HV1V	45	68	14	—	—	—	—	0.6	0.3	15.3	8.30	8.10	18	10.6	16.2	31 900	—
*45BNR29XV1V	45	68	14	—	—	—	—	0.6	0.3	24.3	8.30	8.10	18	10.6	16.2	37 200	—
*45BER29SV1V	45	68	14	—	—	—	—	0.6	0.3	14.7	8.35	14.6	25	—	20.2	21 300	—
*45BER29HV1V	45	68	14	—	—	—	—	0.6	0.3	14.7	8.00	9.85	25	—	20.2	28 400	—
*45BER29XV1V	45	68	14	—	—	—	—	0.6	0.3	23.3	8.00	9.85	25	—	20.2	33 700	—
*7009C	45	75	16	—	—	—	—	1	0.6	30.5	19.3	12.4	15	15.4	16.0	19 200	29 200
*7009CSN24	45	75	16	—	—	—	—	1	0.6	30.5	18.4	14.7	15	15.4	16.0	25 000	38 000
*7009A5	45	75	16	—	—	—	—	1	0.6	29.1	18.3	14.5	25	—	22.0	16 700	25 000
*7009A5SN24	45	75	16	—	—	—	—	1	0.6	29.1	17.5	17.2	25	—	22.0	21 700	32 500
*7009A	45	75	16	—	—	—	—	1	0.6	28.0	17.7	11.1	30	—	25.3	12 500	16 700
*45BNR10E	45	75	16	—	—	—	—	1	0.6	14.7	9.00	12.7	18	10.6	17.6	25 000	35 700
*45BNR10H	45	75	16	—	3.4	9.3	1.4	1	0.6	14.7	8.60	8.35	18	10.6	17.6	30 000	46 700
*45BNR10X	45	75	16	21	3.4	9.3	1.4	1	0.6	23.4	8.60	8.35	18	10.6	17.6	35 000	55 000
*45BER10E	45	75	16	—	—	—	—	1	0.6	14.1	8.60	15.0	25	—	21.8	21 500	30 400
*45BER10H	45	75	16	—	3.4	9.3	1.4	1	0.6	14.1	8.25	10.1	25	—	21.8	26 700	41 700
*45BER10X	45	75	16	21	3.4	9.3	1.4	1	0.6	22.4	8.25	10.1	25	—	21.8	31 700	50 000
*45BNRD10J	45	75	16	—	3.4	9.3	1.4	1	0.6	26.9	9.75	9.40	18	7.9	17.8	30 000	46 700
*45BNRD10X	45	75	16	21	3.4	9.3	1.4	1	0.6	34.0	9.75	9.40	18	7.9	17.8	35 000	55 000
*45BERD10J	45	75	16	—	3.4	9.3	1.4	1	0.6	25.9	9.35	11.5	25	—	22.0	26 700	41 700
*45BERD10X	45	75	16	21	3.4	9.3	1.4	1	0.6	32.5	9.35	11.5	25	—	22.0	31 700	50 000
*45BNR20EV1V	45	75	19	—	—	—	—	1	0.6	14.7	9.00	12.7	18	10.6	19.1	25 000	—
*45BNR20HV1V	45	75	19	—	—	—	—	1	0.6	14.7	8.60	8.35	18	10.6	19.1	30 000	—
*45BNR20XV1V	45	75	19	—	—	—	—	1	0.6	23.4	8.60	8.35	18	10.6	19.1	35 000	—
*45BER20EV1V	45	75	19	—	—	—	—	1	0.6	14.1	8.60	15.0	25	—	23.3	21 500	—
*45BER20HV1V	45	75	19	—	—	—	—	1	0.6	14.1	8.25	10.1	25	—	23.3	26 700	—
*45BER20XV1V	45	75	19	—	—	—	—	1	0.6	22.4	8.25	10.1	25	—	23.3	31 700	—
7209C	45	85	19	—	—	—	—	1.1	0.6	51.5	28.8	19.6	15	14.2	18.2	17 700	27 000
7209CSN24	45	85	19	—	—	—	—	1.1	0.6	51.5	27.8	23.3	15	14.2	18.2	23 100	35 100
7209A5	45	85	19	—	—	—	—	1.1	0.6	49.0	27.6	23.3	25	—	24.7	15 400	23 100
7209A5SN24	45	85	19	—	—	—	—	1.1	0.6	49.5	26.6	27.7	25	—	24.7	20 000	30 000
7209A	45	85	19	—	—	—	—	1.1	0.6	47.5	26.7	18.0	30	—	28.3	11 600	15 400

Abutment and Fillet Dimensions (mm)					Preload (DB and DF Arrangement) (N)				Axial Rigidity (DB and DF Arrangement) (N/μm)				Measured Axial Clearance (μm)				Mass (kg) (approx.)
d_a (min.)	D_a (max.)	D_b (max.)	r_a (max.)	r_b (max.)	EL	L	M	H	EL	L	M	H	EL	L	M	H	
50	63	65.5	0.6	0.3	49	104	192	391	37	51	66	93	0	-5	-11	-21	0.129
50	63	65.5	0.6	0.3	49	111	211	440	41	57	76	108	0	-5	-11	-21	0.115
50	63	65.5	0.6	0.3	70	146	353	676	88	115	160	208	-1	-4	-10	-17	0.130
50	63	65.5	0.6	0.3	72	159	399	776	99	132	187	243	-1	-4	-10	-17	0.116
50	63	65.5	0.6	0.3	49	153	298	—	41	63	82	—	0	-8	-16	—	0.125
50	63	65.5	0.6	0.3	49	168	335	—	46	72	95	—	0	-8	-16	—	0.111
50	63	65.5	0.6	0.3	49	168	335	—	46	72	95	—	0	-8	-16	—	0.111
50	63	65.5	0.6	0.3	49	237	473	—	68	117	151	—	0	-8	-15	—	0.125
50	63	65.5	0.6	0.3	49	265	539	—	76	136	177	—	0	-8	-15	—	0.111
50	63	65.5	0.6	0.3	49	265	539	—	76	136	177	—	0	-8	-15	—	0.111
50	63	65.5	0.6	0.3	49	153	298	—	41	63	82	—	0	-8	-16	—	0.143
50	63	65.5	0.6	0.3	49	168	335	—	46	72	95	—	0	-8	-16	—	0.128
50	63	65.5	0.6	0.3	49	168	335	—	46	72	95	—	0	-8	-16	—	0.128
50	63	65.5	0.6	0.3	49	237	473	—	68	117	151	—	0	-8	-15	—	0.143
50	63	65.5	0.6	0.3	49	265	539	—	76	136	177	—	0	-8	-15	—	0.128
50	63	65.5	0.6	0.3	49	265	539	—	76	136	177	—	0	-8	-15	—	0.128
51	69	70	1	0.5	80	144	338	695	45	57	84	120	-3	-8	-19	-33	0.238
51	69	70	1	0.5	84	156	380	794	51	66	97	140	-3	-8	-19	-33	0.211
51	69	70	1	0.5	94	210	485	958	99	132	181	238	-2	-6	-13	-22	0.250
51	69	70	1	0.5	99	233	553	1 107	113	153	212	280	-2	-6	-13	-22	0.223
51	69	70	1	0.5	49	227	482	1 178	105	176	231	324	0	-5	-10	-20	0.241
51	69	70	1	0.5	49	114	218	—	44	60	77	—	0	-5	-11	—	0.259
51	69	70	1	0.5	49	123	242	—	50	69	89	—	0	-5	-11	—	0.246
51	69	70	1	0.5	49	123	242	—	50	69	89	—	0	-5	-11	—	0.246
51	69	70	1	0.5	49	255	516	—	73	129	168	—	0	-8	-15	—	0.259
51	69	70	1	0.5	49	285	590	—	82	150	197	—	0	-8	-15	—	0.246
51	69	70	1	0.5	49	285	590	—	82	150	197	—	0	-8	-15	—	0.246
51	69	70	1	0.5	49	169	361	—	46	73	97	—	0	-8	-17	—	0.215
51	69	70	1	0.5	49	169	361	—	46	73	97	—	0	-8	-17	—	0.215
51	69	70	1	0.5	49	235	504	—	77	132	174	—	0	-7	-14	—	0.215
51	69	70	1	0.5	49	235	504	—	77	132	174	—	0	-7	-14	—	0.215
51	69	70	1	0.5	49	114	218	—	44	60	77	—	0	-5	-11	—	0.305
51	69	70	1	0.5	49	123	242	—	50	69	89	—	0	-5	-11	—	0.291
51	69	70	1	0.5	49	123	242	—	50	69	89	—	0	-5	-11	—	0.291
51	69	70	1	0.5	49	255	516	—	73	129	168	—	0	-8	-15	—	0.305
51	69	70	1	0.5	49	285	590	—	82	150	197	—	0	-8	-15	—	0.291
51	69	70	1	0.5	49	285	590	—	82	150	197	—	0	-8	-15	—	0.291
52	78	80	1	0.6	123	254	534	1 067	49	67	94	131	-7</				

1. Angular Contact Ball Bearings

Bore Diameter **50mm**

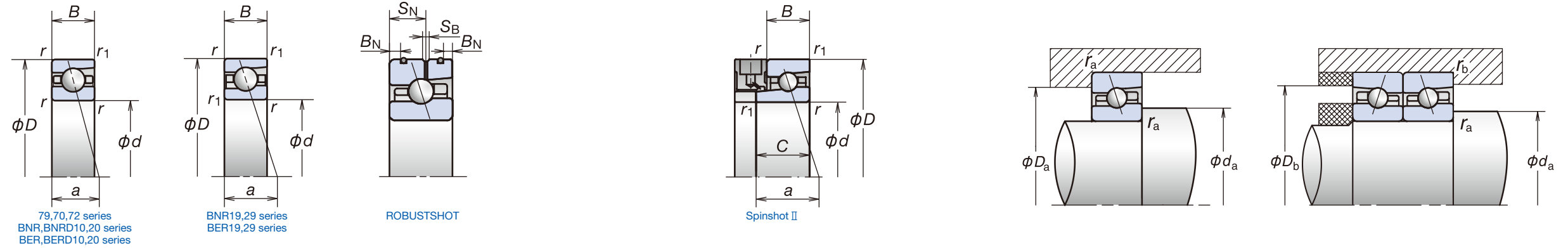

Designation (*)	Boundary Dimensions (°) (mm)							Basic Load Ratings (kN)		Permissible Axial Load (°) (kN)	Contact Angle (°)	Factor <i>f</i> _o	Effective Load Center (mm) <i>a</i>	Limiting Speeds (°) (min ⁻¹)			
	<i>d</i>	<i>D</i>	<i>B</i>	<i>C</i>	<i>B_N</i>	<i>S_N</i>	<i>S_B</i>	<i>r</i> (min.)	<i>r</i> ₁ (min.)					<i>C_r</i> (Dynamic)	<i>C_{or}</i> (Static)	Grease	Oil
*7910C	50	72	12	—	—	—	—	0.6	0.3	21.3	15.0	9.45	15	16.2	14.2	24 600	37 400
*7910CSN24	50	72	12	—	—	—	—	0.6	0.3	21.2	14.3	11.2	15	16.2	14.2	24 600	37 400
*7910A5	50	72	12	—	—	—	—	0.6	0.3	20.1	14.2	11.0	25	—	20.2	16 400	24 600
*7910A5SN24	50	72	12	—	—	—	—	0.6	0.3	20.0	13.5	13.1	25	—	20.2	21 400	32 000
*50BNR19S	50	72	12	—	—	—	—	0.6	0.3	16.1	9.75	13.9	18	10.7	15.9	23 000	32 800
*50BNR19H	50	72	12	—	2.2	7.0	1.4	0.6	0.3	16.1	9.30	9.10	18	10.7	15.9	29 600	46 000
*50BNR19X	50	72	12	17	2.2	7.0	1.4	0.6	0.3	25.6	9.30	9.10	18	10.7	15.9	34 500	54 100
*50BER19S	50	72	12	—	—	—	—	0.6	0.3	15.4	9.35	16.3	25	—	20.2	19 700	27 900
*50BER19H	50	72	12	—	2.2	7.0	1.4	0.6	0.3	15.4	8.95	11.0	25	—	20.2	26 300	41 000
*50BER19X	50	72	12	17	2.2	7.0	1.4	0.6	0.3	24.5	8.95	11.0	25	—	20.2	31 200	49 200
*50BNR29SV1V	50	72	14	—	—	—	—	0.6	0.3	16.1	9.75	13.9	18	10.7	16.9	23 000	—
*50BNR29HV1V	50	72	14	—	—	—	—	0.6	0.3	16.1	9.30	9.10	18	10.7	16.9	29 600	—
*50BNR29XV1V	50	72	14	—	—	—	—	0.6	0.3	25.6	9.30	9.10	18	10.7	16.9	34 500	—
*50BER29SV1V	50	72	14	—	—	—	—	0.6	0.3	15.4	9.35	16.3	25	—	21.2	19 700	—
*50BER29HV1V	50	72	14	—	—	—	—	0.6	0.3	15.4	8.95	11.0	25	—	21.2	26 300	—
*50BER29XV1V	50	72	14	—	—	—	—	0.6	0.3	24.5	8.95	11.0	25	—	21.2	31 200	—
*7010C	50	80	16	—	—	—	—	1	0.6	32.5	21.9	13.9	15	15.7	16.7	17 700	27 000
*7010CSN24	50	80	16	—	—	—	—	1	0.6	32.5	21.0	16.5	15	15.7	16.7	23 100	35 100
*7010A5	50	80	16	—	—	—	—	1	0.6	31.0	20.8	16.2	25	—	23.2	15 400	23 100
*7010A5SN24	50	80	16	—	—	—	—	1	0.6	31.0	19.9	19.3	25	—	23.2	20 000	30 000
*7010A	50	80	16	—	—	—	—	1	0.6	29.8	20.1	12.5	30	—	26.8	11 600	15 400
*50BNR10E	50	80	16	—	—	—	—	1	0.6	15.3	9.90	14.0	18	10.8	18.4	23 100	33 000
*50BNR10H	50	80	16	—	3.4	9.3	1.4	1	0.6	15.3	9.50	9.20	18	10.8	18.4	27 700	43 100
*50BNR10X	50	80	16	21	3.4	9.3	1.4	1	0.6	24.3	9.50	9.20	18	10.8	18.4	32 400	50 800
*50BER10E	50	80	16	—	—	—	—	1	0.6	14.7	9.50	16.5	25	—	23.0	19 900	28 000
*50BER10H	50	80	16	—	3.4	9.3	1.4	1	0.6	14.7	9.10	11.1	25	—	23.0	24 700	38 500
*50BER10X	50	80	16	21	3.4	9.3	1.4	1	0.6	23.3	9.10	11.1	25	—	23.0	29 300	46 200
*50BNRD10J	50	80	16	—	3.4	9.3	1.4	1	0.6	28.7	11.1	10.7	18	8.1	18.6	27 700	43 100
*50BNRD10X	50	80	16	21	3.4	9.3	1.4	1	0.6	36.0	11.1	10.7	18	8.1	18.6	32 400	50 800
*50BERD10J	50	80	16	—	3.4	9.3	1.4	1	0.6	27.6	10.6	13.1	25	—	23.2	24 700	38 500
*50BERD10X	50	80	16	21	3.4	9.3	1.4	1	0.6	35.0	10.6	13.1	25	—	23.2	29 300	46 200
*50BNR20EV1V	50	80	19	—	—	—	—	1	0.6	15.3	9.90	14.0	18	10.8	19.9	23 100	—
*50BNR20HV1V	50	80	19	—	—	—	—	1	0.6	15.3	9.50	9.20	18	10.8	19.9	27 700	—
*50BNR20XV1V	50	80	19	—	—	—	—	1	0.6	24.3	9.50	9.20	18	10.8	19.9	32 400	—
*50BER20EV1V	50	80	19	—	—	—	—	1	0.6	14.7	9.50	16.5	25	—	24.5	19 900	—
*50BER20HV1V	50	80	19	—	—	—	—	1	0.6	14.7	9.10	11.1	25	—	24.5	24 700	—
*50BER20XV1V	50	80	19	—	—	—	—	1	0.6	23.3	9.10	11.1	25	—	24.5	29 300	—
7210C	50	90	20	—	—	—	—	1.1	0.6	54.0	31.5	21.1	15	14.5	19.4	16 500	25 000
7210CSN24	50	90	20	—	—	—	—	1.1	0.6	54.5	30.5	25.0	15	14.5	19.4	20 600	31 300
7210A5	50	90	20	—	—	—	—	1.1	0.6	51.5	30.5	25.2	25	—	26.3	14 300	21 500
7210A5SN24	50	90	20	—	—	—	—	1.1	0.6	52.0	29.3	29.9	25	—	26.3	17 900	26 900
7210A	50	90	20	—	—	—	—	1.1	0.6	49.5	29.3	19.4	30	—	30.2	10 800	14 300

Abutment and Fillet Dimensions (mm)					Preload (DB and DF Arrangement) (N)				Axial Rigidity (DB and DF Arrangement) (N/μm)				Measured Axial Clearance (μm)				Mass (kg) (approx.)
<i>d</i> _a (min.)	<i>D</i> _a (max.)	<i>D</i> _b (max.)	<i>r</i> _a (max.)	<i>r</i> _b (max.)	EL	L	M	H	EL	L	M	H	EL	L	M	H	
55	67	69.5	0.6	0.3	49	95	240	499	40	51	78	111	0	-4	-13	-24	0.130
55	67	69.5	0.6	0.3	49	100	266	565	44	58	89	129	0	-4	-13	-24	0.114
55	67	69.5	0.6	0.3	71	154	379	791	94	124	175	235	-1	-4	-10	-18	0.132
55	67	69.5	0.6	0.3	74	168	430	911	107	143	204	276	-1	-4	-10	-18	0.116
55	67	69.5	0.6	0.3	49	162	319	—	44	68	89	—	0	-8	-16	—	0.127
55	67	69.5	0.6	0.3	49	177	359	—	49	78	103	—	0	-8	-16	—	0.111
55	67	69.5	0.6	0.3	49	177	359	—	49	78	103	—	0	-8	-16	—	0.111
55	67	69.5	0.6	0.3	49	253	511	—	73	128	166	—	0	-8	-15	—	0.127
55	67	69.5	0.6	0.3	49	283	584	—	81	149	194	—	0	-8	-15	—	0.111
55	67	69.5	0.6	0.3	49	283	584	—	81	149	194	—	0	-8	-15	—	0.111
55	67	69.5	0.6	0.3	49	162	319	—	44	68	89	—	0	-8	-16	—	0.144
55	67	69.5	0.6	0.3	49	177	359	—	49	78	103	—	0	-8	-16	—	0.128
55	67	69.5	0.6	0.3	49	177	359	—	49	78	103	—	0	-8	-16	—	0.128
55	67	69.5	0.6	0.3	49	253	511	—	73	128	166	—	0	-8	-15	—	0.144
55	67	69.5	0.6	0.3	49	283	584	—	81	149	194	—	0	-8	-15	—	0.128
55	67	69.5	0.6	0.3	49	283	584	—	81	149	194	—	0	-8	-15	—	0.128
56	74	75	1	0.5	70	152	388	791	46	63	95	135	-2	-8	-20	-34	0.259
56	74	75	1	0.5	73	165	438	906	51	72	110	158	-2	-8	-20	-34	0.228
56	74	75	1	0.5	125	262	580	1 189	118	154	208	278	-3	-7	-14	-24	0.270
56	74	75	1	0.5	136	293	664	1 379	135	179	244	327	-3	-7	-14	-24	0.239
56	74	75	1	0.5	49	243	525	1 299	113	194	256	360	0	-5	-10	-20	0.262
56	74	75	1	0.5	49	119	250	—	47	64	86	—	0	-5	-12	—	0.281
56	74	75	1	0.5	49	128	280	—	52	74	100	—	0	-5	-12	—	0.266
56	74	75	1	0.5	49	128	280	—	52	74	100	—	0	-5	-12	—	0.266
56	74	75	1	0.5	49	270	552	—	78	140	182	—	0	-8	-15	—	0.281
56	74	75	1	0.5	49	303	633	—	87	162	213	—	0	-8	-15	—	0.266
56	74	75	1	0.5	49	303	633	—	87	162	213	—	0	-8	-15	—	0.266
56	74	75	1	0.5	49	200	418	—	50	83	110	—	0	-9	-18	—	0.234
56	74	75	1	0.5	49	200	418	—	50	83	110	—	0	-9	-18	—	0.234
56	74	75	1	0.5	49	290	551	—	83	153	193	—	0	-8	-14	—	0.234
56	74	75	1	0.5	49	290	551	—	83	153	193	—	0	-8	-14	—	0.234
56	74	75	1	0.5	49	119	250	—	47	64	86	—	0	-5	-12	—	0.330
56	74	75	1	0.5	49	128	280	—	52	74	100	—	0	-5	-12	—	0.315
56	74	75	1	0.5	49	128	280	—	52	74	100	—	0	-5	-12	—	0.315
56	74	75	1	0.5	49	270	552	—	78	140	182	—	0	-8	-15	—	0.330
56	74	75	1	0.5	49	303	633	—	87	162	213	—	0	-8	-15	—	0.315
56	74	75	1	0.5	49	303	633	—	87	162	213	—	0	-8	-15	—	0.315
57	83	85															

1. Angular Contact Ball Bearings

Bore Diameter **55mm**

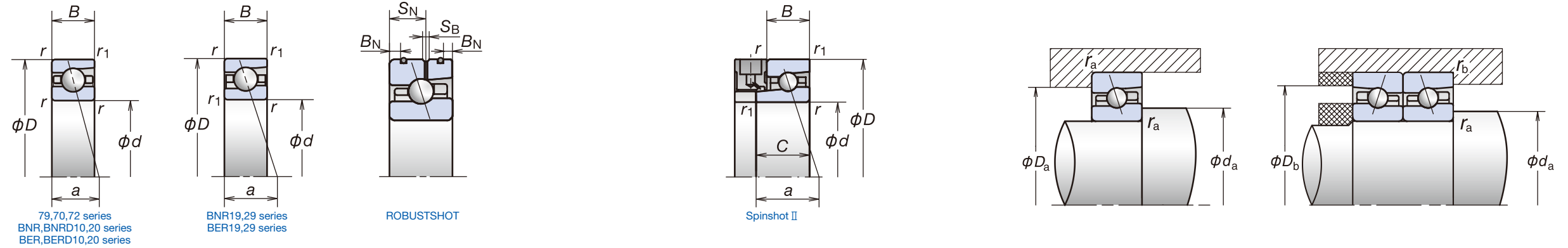

Designation (*)	Boundary Dimensions (*) (mm)								Basic Load Ratings (kN)		Permissible Axial Load (*) (kN)	Contact Angle (°)	Factor f_0	Effective Load Center (mm) a	Limiting Speeds (*) (min ⁻¹)		
	d	D	B	C	B_N	S_N	S_B	r (min.)	r_1 (min.)	C_r (Dynamic)					C_{or} (Static)	Grease	Oil
*7911C	55	80	13	—	—	—	—	1	0.6	24.1	17.7	11.0	15	16.3	15.5	17 100	26 000
*7911CSN24	55	80	13	—	—	—	—	1	0.6	24.5	17.3	13.0	15	16.3	15.5	22 300	33 800
*7911A5	55	80	13	—	—	—	—	1	0.6	22.8	16.8	12.5	25	—	22.2	14 900	22 300
*7911A5SN24	55	80	13	—	—	—	—	1	0.6	23.1	16.4	14.8	25	—	22.2	19 300	28 900
*55BNR19E	55	80	13	—	—	—	—	1	0.6	18.1	11.4	16.2	18	10.7	17.5	22 300	31 800
*55BNR19H	55	80	13	—	2.8	7.5	1.4	1	0.6	18.1	10.9	10.6	18	10.7	17.5	26 700	41 500
*55BNR19X	55	80	13	18	2.8	7.5	1.4	1	0.6	28.8	10.9	10.6	18	10.7	17.5	31 200	48 900
*55BER19E	55	80	13	—	—	—	—	1	0.6	17.3	10.9	16.1	25	—	22.2	19 200	27 000
*55BER19H	55	80	13	—	2.8	7.5	1.4	1	0.6	17.3	10.4	12.9	25	—	22.2	23 800	37 100
*55BER19X	55	80	13	18	2.8	7.5	1.4	1	0.6	27.5	10.4	12.9	25	—	22.2	28 200	44 500
*55BNR29EV1V	55	80	16	—	—	—	—	1	0.6	18.1	11.4	16.2	18	10.7	19.0	22 300	—
*55BNR29HV1V	55	80	16	—	—	—	—	1	0.6	18.1	10.9	10.6	18	10.7	19.0	26 700	—
*55BNR29XV1V	55	80	16	—	—	—	—	1	0.6	28.8	10.9	10.6	18	10.7	19.0	31 200	—
*55BER29EV1V	55	80	16	—	—	—	—	1	0.6	17.3	10.9	16.1	25	—	23.7	19 200	—
*55BER29HV1V	55	80	16	—	—	—	—	1	0.6	17.3	10.4	12.9	25	—	23.7	23 800	—
*55BER29XV1V	55	80	16	—	—	—	—	1	0.6	27.5	10.4	12.9	25	—	23.7	28 200	—
*7011C	55	90	18	—	—	—	—	1.1	0.6	43.0	28.6	18.9	15	15.5	18.7	15 900	24 200
*7011CSN24	55	90	18	—	—	—	—	1.1	0.6	42.5	27.1	22.4	15	15.5	18.7	20 700	31 500
*7011A5	55	90	18	—	—	—	—	1.1	0.6	41.0	27.2	21.8	25	—	25.9	13 800	20 700
*7011A5SN24	55	90	18	—	—	—	—	1.1	0.6	40.5	25.7	25.8	25	—	25.9	18 000	26 900
*7011A	55	90	18	—	—	—	—	1.1	0.6	39.0	26.3	16.6	30	—	29.9	10 400	13 800
*55BNR10E	55	90	18	—	—	—	—	1.1	0.6	19.0	12.5	17.8	18	10.8	20.6	20 700	29 600
*55BNR10H	55	90	18	—	4.3	10.0	1.4	1.1	0.6	19.0	12.0	11.7	18	10.8	20.6	24 900	38 700
*55BNR10X	55	90	18	23	4.3	10.0	1.4	1.1	0.6	30.0	12.0	11.7	18	10.8	20.6	29 000	45 600
*55BER10E	55	90	18	—	—	—	—	1.1	0.6	18.1	12.0	21.0	25	—	25.7	17 800	25 200
*55BER10H	55	90	18	—	4.3	10.0	1.4	1.1	0.6	18.1	11.5	14.1	25	—	25.7	22 100	34 500
*55BER10X	55	90	18	23	4.3	10.0	1.4	1.1	0.6	28.8	11.5	14.1	25	—	25.7	26 300	41 400
*55BNRD10J	55	90	18	—	4.3	10	1.4	1.1	0.6	37.5	14.5	13.9	18	8.0	20.8	24 900	38 700
*55BNRD10X	55	90	18	23	4.3	10	1.4	1.1	0.6	47.5	14.5	13.9	18	8.0	20.8	29 000	45 600
*55BERD10J	55	90	18	—	4.3	10	1.4	1.1	0.6	36.0	13.9	17.1	25	—	25.9	22 100	34 500
*55BERD10X	55	90	18	23	4.3	10	1.4	1.1	0.6	45.5	13.9	17.1	25	—	25.9	26 300	41 400
*55BNR20EV1V	55	90	22	—	—	—	—	1.1	0.6	19.0	12.5	17.8	18	10.8	22.6	20 700	—
*55BNR20HV1V	55	90	22	—	—	—	—	1.1	0.6	19.0	12.0	11.7	18	10.8	22.6	24 900	—
*55BNR20XV1V	55	90	22	—	—	—	—	1.1	0.6	30.0	12.0	11.7	18	10.8	22.6	29 000	—
*55BER20EV1V	55	90	22	—	—	—	—	1.1	0.6	18.1	12.0	21.0	25	—	27.7	17 800	—
*55BER20HV1V	55	90	22	—	—	—	—	1.1	0.6	18.1	11.5	14.1	25	—	27.7	22 100	—
*55BER20XV1V	55	90	22	—	—	—	—	1.1	0.6	28.8	11.5	14.1	25	—	27.7	26 300	—
7211C	55	100	21	—	—	—	—	1.5	1	66.5	40.0	27.6	15	14.5	20.9	14 900	22 600
7211CSN24	55	100	21	—	—	—	—	1.5	1	66.5	38.0	32.8	15	14.5	20.9	19 400	29 500
7211A5	55	100	21	—	—	—	—	1.5	1	63.5	38.0	32.5	25	—	28.6	13 000	19 400
7211A5SN24	55	100	21	—	—	—	—	1.5	1	63.5	36.5	38.6	25	—	28.6	16 800	25 200
7211A	55	100	21	—	—	—	—	1.5	1	61.5	37.0	25.0	30	—	32.9	9 700	13 000

Abutment and Fillet Dimensions (mm)					Preload (DB and DF Arrangement) (N)				Axial Rigidity (DB and DF Arrangement) (N/μm)				Measured Axial Clearance (μm)				Mass (kg) (approx.)
d_a (min.)	D_a (max.)	D_b (max.)	r_a (max.)	r_b (max.)	EL	L	M	H	EL	L	M	H	EL	L	M	H	
61	74	75	1	0.5	60	111	296	593	45	58	90	126	-1	-5	-15	-26	0.182
61	74	75	1	0.5	61	119	331	675	50	66	104	147	-1	-5	-15	-26	0.163
61	74	75	1	0.5	99	196	454	917	113	144	198	264	-2	-5	-11	-19	0.184
61	74	75	1	0.5	106	217	517	1 059	129	167	232	309	-2	-5	-11	-19	0.165
61	74	75	1	0.5	49	167	333	—	46	72	94	—	0	-8	-16	—	0.178
61	74	75	1	0.5	49	184	375	—	51	82	109	—	0	-8	-16	—	0.158
61	74	75	1	0.5	49	184	375	—	51	82	109	—	0	-8	-16	—	0.158
61	74	75	1	0.5	49	184	375	—	51	82	109	—	0	-8	-16	—	0.158
61	74	75	1	0.5	49	264	538	—	76	136	176	—	0	-8	-15	—	0.178
61	74	75	1	0.5	49	264	538	—	76	136	176	—	0	-8	-15	—	0.178
61	74	75	1	0.5	49	296	615	—	85	158	206	—	0	-8	-15	—	0.158
61	74	75	1	0.5	49	296	615	—	85	158	206	—	0	-8	-15	—	0.158
61	74	75	1	0.5	49	296	615	—	85	158	206	—	0	-8	-15	—	0.158
61	74	75	1	0.5	49	167	333	—	46	72	94	—	0	-8	-16	—	0.213
61	74	75	1	0.5	49	184	375	—	51	82	109	—	0	-8	-16	—	0.194
61	74	75	1	0.5	49	184	375	—	51	82	109	—	0	-8	-16	—	0.194
61	74	75	1	0.5	49	184	375	—	51	82	109	—	0	-8	-16	—	0.194
61	74	75	1	0.5	49	264	538	—	76	136	176	—	0	-8	-15	—	0.213
61	74	75	1	0.5	49	264	538	—	76	136	176	—	0	-8	-15	—	0.213
61	74	75	1	0.5	49	296	615	—	85	158	206	—	0	-8	-15	—	0.194
61	74	75	1	0.5	49	296	615	—	85	158	206	—	0	-8	-15	—	0.194
62	83	85	1	0.6	95	200	479	971	51	69	102	144	-4	-11	-24	-40	0.380
62	83	85	1	0.6	100	221	544	1 118	58	80	119	169	-4	-11	-24	-40	0.332
62	83	85	1	0.6	157	345	804	1 552	129	171	236	307	-4	-9	-18	-29	0.383
62	83	85	1	0.6	172	391	928	1 807	148	199	277	362	-4	-9	-18	-29	0.335
62	83	85	1	0.6	49	246	887	1 307	115	196	311	360	0	-5	-15	-20	0.385
62	83	85	1	0.6	49	121	305	—	49	67	95	—	0	-5	-14	—	0.414
62	83	85	1	0.6	49	131	343	—	54	77	111	—	0	-5	-14	—	0.393
62	83	85	1	0.6	49	131	343	—	54	77	111	—	0	-5	-14	—	0.393
62	83	85	1	0.6	49	356	725	—	81	160	208	—	0	-10	-18	—	0.414
62	83	85	1	0.6	49	404	836	—	90	186	244	—	0	-10	-18	—	0.393
62	83	85	1	0.6	49	404	836	—	90	186	244	—	0	-10	-18	—	0.393
62	83	85	1	0.6	49	268	567	—	50	93	124	—	0	-12	-23	—	0.338
62	83	85	1	0.6	49	268	567	—	50	93	124	—	0	-12	-23	—	0.338
62	83	85	1	0.6	49	376	766	—	84	170	219	—	0	-10	-18	—	0.338
62	83	85	1	0.6	49	376	766	—	84	170	219	—	0	-10	-18	—	0.338
62	83	85	1	0.6	49	121	305	—	49	67	95	—	0	-5	-14	—	0.501
62	83	85	1	0.6	49	131	343	—	54	77	111	—	0	-5	-14	—	0.480
62	83	85	1	0.6	49</												

1. Angular Contact Ball Bearings

Bore Diameter **60mm**

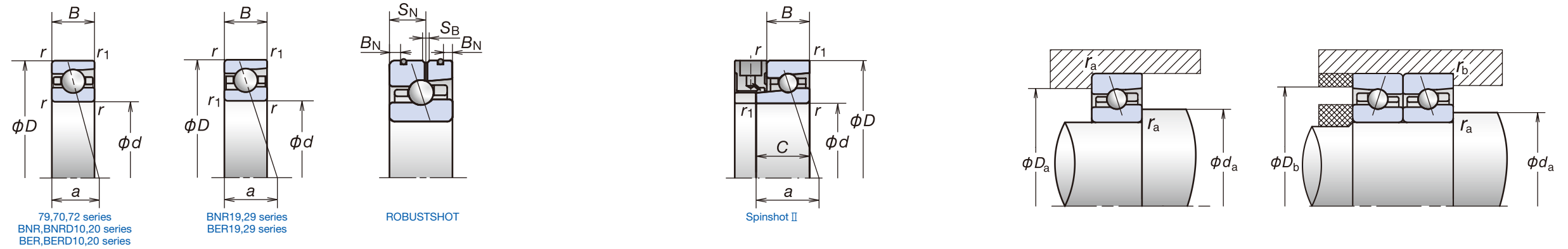

Designation (*)	Boundary Dimensions (*) (mm)								Basic Load Ratings (kN)		Permissible Axial Load (*) (kN)	Contact Angle (°)	Factor f _o	Effective Load Center (mm) a	Limiting Speeds (*) (min ⁻¹)		
	d	D	B	C	B _N	S _N	S _B	r (min.)	r ₁ (min.)	C _r (Dynamic)					C _{or} (Static)	Grease	Oil
*7912C	60	85	13	—	—	—	—	1	0.6	24.5	18.7	11.5	15	16.5	16.2	15 900	24 200
*7912CSN24	60	85	13	—	—	—	—	1	0.6	24.8	18.3	13.6	15	16.5	16.2	20 700	31 500
*7912A5	60	85	13	—	—	—	—	1	0.6	23.1	17.7	13.0	25	—	23.4	13 800	20 700
*7912A5SN24	60	85	13	—	—	—	—	1	0.6	23.4	17.3	15.5	25	—	23.4	18 000	26 900
*60BNR19E	60	85	13	—	—	—	—	1	0.6	18.4	12.0	17.1	18	10.7	18.3	20 700	29 600
*60BNR19H	60	85	13	—	2.8	7.5	1.4	1	0.6	18.4	11.5	11.2	18	10.7	18.3	24 900	38 700
*60BNR19X	60	85	13	18	2.8	7.5	1.4	1	0.6	29.2	11.5	11.2	18	10.7	18.3	29 000	45 600
*60BER19E	60	85	13	—	—	—	—	1	0.6	17.6	11.5	20.1	25	—	23.4	17 800	25 200
*60BER19H	60	85	13	—	2.8	7.5	1.4	1	0.6	17.6	11.0	13.6	25	—	23.4	22 100	34 500
*60BER19X	60	85	13	18	2.8	7.5	1.4	1	0.6	27.9	11.0	13.6	25	—	23.4	26 300	41 400
*60BNR29EV1V	60	85	16	—	—	—	—	1	0.6	18.4	12.0	17.1	18	10.7	19.8	20 700	—
*60BNR29HV1V	60	85	16	—	—	—	—	1	0.6	18.4	11.5	11.2	18	10.7	19.8	24 900	—
*60BNR29XV1V	60	85	16	—	—	—	—	1	0.6	29.2	11.5	11.2	18	10.7	19.8	29 000	—
*60BER29EV1V	60	85	16	—	—	—	—	1	0.6	17.6	11.5	20.1	25	—	24.9	17 800	—
*60BER29HV1V	60	85	16	—	—	—	—	1	0.6	17.6	11.0	13.6	25	—	24.9	22 100	—
*60BER29XV1V	60	85	16	—	—	—	—	1	0.6	27.9	11.0	13.6	25	—	24.9	26 300	—
*7012C	60	95	18	—	—	—	—	1.1	0.6	44.0	30.5	19.9	15	15.7	19.4	14 900	22 600
*7012CSN24	60	95	18	—	—	—	—	1.1	0.6	44.0	29.0	23.6	15	15.7	19.4	19 400	29 500
*7012A5	60	95	18	—	—	—	—	1.1	0.6	42.0	29.1	23.0	25	—	27.1	13 000	19 400
*7012A5SN24	60	95	18	—	—	—	—	1.1	0.6	41.5	27.5	27.3	25	—	27.1	16 800	25 200
*7012A	60	95	18	—	—	—	—	1.1	0.6	40.0	28.1	17.6	30	—	31.4	9 700	13 000
*60BNR10E	60	95	18	—	—	—	—	1.1	0.6	19.7	13.7	19.5	18	10.8	21.5	19 400	27 700
*60BNR10H	60	95	18	—	4.3	10	1.4	1.1	0.6	19.7	13.1	12.8	18	10.8	21.5	23 300	36 200
*60BNR10X	60	95	18	23	4.3	10	1.4	1.1	0.6	31.5	13.1	12.8	18	10.8	21.5	27 100	42 600
*60BER10E	60	95	18	—	—	—	—	1.1	0.6	18.8	13.1	22.9	25	—	26.9	16 700	23 500
*60BER10H	60	95	18	—	4.3	10	1.4	1.1	0.6	18.8	12.5	15.5	25	—	26.9	20 700	32 300
*60BER10X	60	95	18	23	4.3	10	1.4	1.1	0.6	29.9	12.5	15.5	25	—	26.9	24 600	38 800
*60BNRD10J	60	95	18	—	4.3	10	1.4	1.1	0.6	39.0	15.5	14.9	18	8.1	21.6	23 300	36 200
*60BNRD10X	60	95	18	23	4.3	10	1.4	1.1	0.6	49.0	15.5	14.9	18	8.1	21.6	27 100	42 600
*60BERD10J	60	95	18	—	4.3	10	1.4	1.1	0.6	37.5	14.9	18.3	25	—	27.1	20 700	32 300
*60BERD10X	60	95	18	23	4.3	10	1.4	1.1	0.6	47.0	14.9	18.3	25	—	27.1	24 600	38 800
*60BNR20EV1V	60	95	22	—	—	—	—	1.1	0.6	19.7	13.7	19.5	18	10.8	23.5	19 400	—
*60BNR20HV1V	60	95	22	—	—	—	—	1.1	0.6	19.7	13.1	12.8	18	10.8	23.5	23 300	—
*60BNR20XV1V	60	95	22	—	—	—	—	1.1	0.6	31.5	13.1	12.8	18	10.8	23.5	27 100	—
*60BER20EV1V	60	95	22	—	—	—	—	1.1	0.6	18.8	13.1	22.9	25	—	28.9	16 700	—
*60BER20HV1V	60	95	22	—	—	—	—	1.1	0.6	18.8	12.5	15.5	25	—	28.9	20 700	—
*60BER20XV1V	60	95	22	—	—	—	—	1.1	0.6	29.9	12.5	15.5	25	—	28.9	24 600	—
7212C	60	110	22	—	—	—	—	1.5	1	80.5	49.0	34.0	15	14.4	22.4	13 600	20 600
7212CSN24	60	110	22	—	—	—	—	1.5	1	80.0	46.5	40.6	15	14.4	22.4	17 700	26 900
7212A5	60	110	22	—	—	—	—	1.5	1	77.0	47.0	40.0	25	—	30.8	11 800	17 700
7212A5SN24	60	110	22	—	—	—	—	1.5	1	76.5	44.5	47.3	25	—	30.8	15 300	23 000
7212A	60	110	22	—	—	—	—	1.5	1	74.5	45.5	30.5	30	—	35.5	8 900	11 800

Abutment and Fillet Dimensions (mm)					Preload (DB and DF Arrangement) (N)				Axial Rigidity (DB and DF Arrangement) (N/μm)				Measured Axial Clearance (μm)				Mass (kg) (approx.)
d _a (min.)	D _a (max.)	D _b (max.)	r _a (max.)	r _b (max.)	EL	L	M	H	EL	L	M	H	EL	L	M	H	
66	79	80	1	0.5	60	113	305	581	46	60	93	128	-1	-5	-15	-25	0.195
66	79	80	1	0.5	61	122	341	661	52	68	108	149	-1	-5	-15	-25	0.175
66	79	80	1	0.5	101	201	419	884	117	150	198	267	-2	-5	-10	-18	0.198
66	79	80	1	0.5	108	223	477	1 021	133	173	231	313	-2	-5	-10	-18	0.175
66	79	80	1	0.5	49	171	343	—	47	74	97	—	0	-8	-16	—	0.190
66	79	80	1	0.5	49	189	388	—	53	86	113	—	0	-8	-16	—	0.170
66	79	80	1	0.5	49	189	388	—	53	86	113	—	0	-8	-16	—	0.170
66	79	80	1	0.5	49	272	557	—	78	141	183	—	0	-8	-15	—	0.190
66	79	80	1	0.5	49	306	638	—	88	164	215	—	0	-8	-15	—	0.170
66	79	80	1	0.5	49	306	638	—	88	164	215	—	0	-8	-15	—	0.170
66	79	80	1	0.5	49	171	343	—	47	74	97	—	0	-8	-16	—	0.228
66	79	80	1	0.5	49	189	388	—	53	86	113	—	0	-8	-16	—	0.208
66	79	80	1	0.5	49	189	388	—	53	86	113	—	0	-8	-16	—	0.208
66	79	80	1	0.5	49	272	557	—	78	141	183	—	0	-8	-15	—	0.228
66	79	80	1	0.5	49	306	638	—	88	164	215	—	0	-8	-15	—	0.208
66	79	80	1	0.5	49	306	638	—	88	164	215	—	0	-8	-15	—	0.208
67	88	90	1	0.6	96	189	526	1 092	53	70	110	157	-4	-10	-25	-42	0.405
67	88	90	1	0.6	102	208	598	1 259	60	80	128	184	-4	-10	-25	-42	0.354
67	88	90	1	0.6	162	359	780	1 549	134	179	241	317	-4	-9	-17	-28	0.408
67	88	90	1	0.6	178	407	900	1 803	155	209	283	373	-4	-9	-17	-28	0.357
67	88	90	1	0.6	49	255	929	1 371	119	206	328	379	0	-5	-15	-20	0.410
67	88	90	1	0.6	49	126	348	—	51	71	105	—	0	-5	-15	—	0.443
67	88	90	1	0.6	49	136	393	—	57	82	123	—	0	-5	-15	—	0.419
67	88	90	1	0.6	49	136	393	—	57	82	123	—	0	-5	-15	—	0.419
67	88	90	1	0.6	49	378	775	—	85	172	224	—	0	-10	-18	—	0.443
67	88	90	1	0.6	49	429	894	—	95	200	263	—	0	-10	-18	—	0.419
67	88	90	1	0.6	49	429	894	—	95	200	263	—	0	-10	-18	—	0.419
67	88	90	1	0.6	49	278	592	—	52	97	130	—	0	-12	-23	—	0.361
67	88	90	1	0.6	49	278	592	—	52	97	130	—	0	-12	-23	—	0.361
67	88	90	1	0.6	49	391	801	—	87	178	231	—	0	-10	-18	—	0.361
67	88	90	1	0.6	49	391	801	—	87	178	231	—	0	-10	-18	—	0.361
67	88	90	1	0.6	49	126	348	—	51	71	105	—	0	-5	-15	—	0.535
67	88	90	1	0.6	49	136	393	—	57	82	123	—	0	-5	-15	—	0.512
67	88	90	1	0.6	49	136	393	—	57	82	123	—	0	-5	-15	—	0.512
67	88	90	1	0.6	49	378	775	—	85	172	224	—	0	-10	-18	—	0.535
67	88	90	1	0.6	49	429	894	—	95	200	263	—	0	-10	-18	—	0.512
67	88	90	1	0.6	49	429	894	—	95	200	263	—	0	-10	-18	—	0.512
69	101	104	1.5	0.8	190	397	928	1 878	64	86	126	178	-11				

1. Angular Contact Ball Bearings

Bore Diameter **65mm**

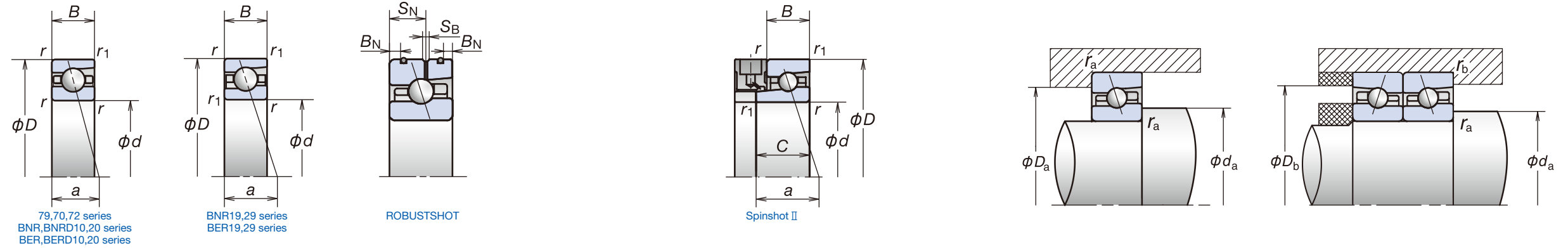

Designation (*)	Boundary Dimensions (*) (mm)								Basic Load Ratings (kN)		Permissible Axial Load (*) (kN)	Contact Angle (°)	Factor f_0	Effective Load Center (mm) a	Limiting Speeds (*) (min ⁻¹)		
	d	D	B	C	B_N	S_N	S_β	r (min.)	r_1 (min.)	C_r (Dynamic)					C_{or} (Static)	Grease	Oil
*7913C	65	90	13	—	—	—	—	1	0.6	25.5	20.5	12.5	15	16.7	16.9	14 900	22 600
*7913CSN24	65	90	13	—	—	—	—	1	0.6	25.9	20.1	14.8	15	16.7	16.9	19 400	29 500
*7913A5	65	90	13	—	—	—	—	1	0.6	24.0	19.4	14.2	25	—	24.6	13 000	19 400
*7913A5SN24	65	90	13	—	—	—	—	1	0.6	24.4	19.0	16.8	25	—	24.6	16 800	25 200
*65BNR19E	65	90	13	—	—	—	—	1	0.6	19.2	13.2	18.7	18	10.8	19.1	19 400	27 700
*65BNR19H	65	90	13	—	2.8	7.5	1.4	1	0.6	19.2	12.6	12.3	18	10.8	19.1	23 300	36 200
*65BNR19X	65	90	13	18	2.8	7.5	1.4	1	0.6	30.5	12.6	12.3	18	10.8	19.1	27 100	42 600
*65BER19E	65	90	13	—	—	—	—	1	0.6	18.3	12.6	22.1	25	—	24.6	16 700	23 500
*65BER19H	65	90	13	—	2.8	7.5	1.4	1	0.6	18.3	12.1	14.9	25	—	24.6	20 700	32 300
*65BER19X	65	90	13	18	2.8	7.5	1.4	1	0.6	29.1	12.1	14.9	25	—	24.6	24 600	38 800
*65BNR29EV1V	65	90	16	—	—	—	—	1	0.6	19.2	13.2	18.7	18	10.8	20.6	19 400	—
*65BNR29HV1V	65	90	16	—	—	—	—	1	0.6	19.2	12.6	12.3	18	10.8	20.6	23 300	—
*65BNR29XV1V	65	90	16	—	—	—	—	1	0.6	30.5	12.6	12.3	18	10.8	20.6	27 100	—
*65BER29EV1V	65	90	16	—	—	—	—	1	0.6	18.3	12.6	22.1	25	—	26.1	16 700	—
*65BER29HV1V	65	90	16	—	—	—	—	1	0.6	18.3	12.1	14.9	25	—	26.1	20 700	—
*65BER29XV1V	65	90	16	—	—	—	—	1	0.6	29.1	12.1	14.9	25	—	26.1	24 600	—
*7013C	65	100	18	—	—	—	—	1.1	0.6	47.0	34.5	22.0	15	15.9	20.0	14 000	21 300
*7013CSN24	65	100	18	—	—	—	—	1.1	0.6	46.5	32.5	26.1	15	15.9	20.0	18 200	27 700
*7013A5	65	100	18	—	—	—	—	1.1	0.6	44.0	32.5	25.4	25	—	28.2	12 200	18 200
*7013A5SN24	65	100	18	—	—	—	—	1.1	0.6	44.0	31.0	30.2	25	—	28.2	15 800	23 700
*7013A	65	100	18	—	—	—	—	1.1	0.6	42.5	31.5	19.5	30	—	32.8	9 100	12 200
*65BNR10E	65	100	18	—	—	—	—	1.1	0.6	20.4	14.8	21.1	18	10.9	22.3	18 200	26 000
*65BNR10H	65	100	18	—	4.0	10.4	1.4	1.1	0.6	20.4	14.2	13.9	18	10.9	22.3	21 900	34 000
*65BNR10X	65	100	18	23	4.0	10.4	1.4	1.1	0.6	32.5	14.2	13.9	18	10.9	22.3	25 500	40 000
*65BER10E	65	100	18	—	—	—	—	1.1	0.6	19.5	14.2	24.9	25	—	28.0	15 700	22 100
*65BER10H	65	100	18	—	4.0	10.4	1.4	1.1	0.6	19.5	13.6	16.8	25	—	28.0	19 400	30 400
*65BER10X	65	100	18	23	4.0	10.4	1.4	1.1	0.6	31.0	13.6	16.8	25	—	28.0	23 100	36 400
*65BNRD10J	65	100	18	—	4.0	10.4	1.4	1.1	0.6	41.0	17.3	16.7	18	8.1	22.4	21 900	34 000
*65BNRD10X	65	100	18	23	4.0	10.4	1.4	1.1	0.6	52.0	17.3	16.7	18	8.1	22.4	25 500	40 000
*65BERD10J	65	100	18	—	4.0	10.4	1.4	1.1	0.6	39.5	16.7	20.5	25	—	28.2	19 400	30 400
*65BERD10X	65	100	18	23	4.0	10.4	1.4	1.1	0.6	50.0	16.7	20.5	25	—	28.2	23 100	36 400
*65BNR20EV1V	65	100	22	—	—	—	—	1.1	0.6	20.4	14.8	21.1	18	10.9	24.3	18 200	—
*65BNR20HV1V	65	100	22	—	—	—	—	1.1	0.6	20.4	14.2	13.9	18	10.9	24.3	21 900	—
*65BNR20XV1V	65	100	22	—	—	—	—	1.1	0.6	32.5	14.2	13.9	18	10.9	24.3	25 500	—
*65BER20EV1V	65	100	22	—	—	—	—	1.1	0.6	19.5	14.2	24.9	25	—	30.0	15 700	—
*65BER20HV1V	65	100	22	—	—	—	—	1.1	0.6	19.5	13.6	16.8	25	—	30.0	19 400	—
*65BER20XV1V	65	100	22	—	—	—	—	1.1	0.6	31.0	13.6	16.8	25	—	30.0	23 100	—
7213C	65	120	23	—	—	—	—	1.5	1	92.0	58.5	40.0	15	14.6	23.9	12 500	19 000
7213CSN24	65	120	23	—	—	—	—	1.5	1	92.0	56.0	47.5	15	14.6	23.9	16 300	24 700
7213A5	65	120	23	—	—	—	—	1.5	1	88.0	56.0	46.5	25	—	33.1	10 900	16 300
7213A5SN24	65	120	23	—	—	—	—	1.5	1	87.5	53.5	55.4	25	—	33.1	14 100	21 100
7213A	65	120	23	—	—	—	—	1.5	1	85.0	54.0	36.0	30	—	38.2	8 200	10 900

Abutment and Fillet Dimensions (mm)					Preload (DB and DF Arrangement) (N)				Axial Rigidity (DB and DF Arrangement) (N/μm)				Measured Axial Clearance (μm)				Mass (kg) (approx.)
d_a (min.)	D_a (max.)	D_b (max.)	r_a (max.)	r_b (max.)	EL	L	M	H	EL	L	M	H	EL	L	M	H	
71	84	85	1	0.5	74	151	348	690	53	71	104	145	-2	-7	-16	-27	0.208
71	84	85	1	0.5	76	164	391	787	59	81	120	169	-2	-7	-16	-27	0.186
71	84	85	1	0.5	104	212	500	948	124	161	223	288	-2	-5	-11	-18	0.211
71	84	85	1	0.5	112	235	572	1 096	142	186	261	338	-2	-5	-11	-18	0.189
71	84	85	1	0.5	49	179	364	—	50	80	105	—	0	-8	-16	—	0.204
71	84	85	1	0.5	49	198	412	—	56	92	122	—	0	-8	-16	—	0.181
71	84	85	1	0.5	49	198	412	—	56	92	122	—	0	-8	-16	—	0.181
71	84	85	1	0.5	49	288	595	—	83	152	198	—	0	-8	-15	—	0.204
71	84	85	1	0.5	49	324	683	—	93	177	232	—	0	-8	-15	—	0.181
71	84	85	1	0.5	49	324	683	—	93	177	232	—	0	-8	-15	—	0.181
71	84	85	1	0.5	49	179	364	—	50	80	105	—	0	-8	-16	—	0.245
71	84	85	1	0.5	49	198	412	—	56	92	122	—	0	-8	-16	—	0.223
71	84	85	1	0.5	49	198	412	—	56	92	122	—	0	-8	-16	—	0.223
71	84	85	1	0.5	49	288	595	—	83	152	198	—	0	-8	-15	—	0.245
71	84	85	1	0.5	49	324	683	—	93	177	232	—	0	-8	-15	—	0.223
71	84	85	1	0.5	49	324	683	—	93	177	232	—	0	-8	-15	—	0.223
72	93	95	1	0.6	130	260	537	1 062	64	85	117	163	-6	-13	-24	-39	0.435
72	93	95	1	0.6	141	290	612	1 224	73	98	136	191	-6	-13	-24	-39	0.379
72	93	95	1	0.6	209	386	915	1 781	157	196	272	356	-5	-9	-18	-29	0.455
72	93	95	1	0.6	232	439	1 059	2 077	182	229	320	420	-5	-9	-18	-29	0.399
72	93	95	1	0.6	49	272	1 012	1 498	127	225	360	418	0	-5	-15	-20	0.441
72	93	95	1	0.6	49	130	367	—	54	76	113	—	0	-5	-15	—	0.472
72	93	95	1	0.6	49	141	415	—	60	87	131	—	0	-5	-15	—	0.447
72	93	95	1	0.6	49	141	415	—	60	87	131	—	0	-5	-15	—	0.447
72	93	95	1	0.6	49	399	824	—	89	184	240	—	0	-10	-18	—	0.472
72	93	95	1	0.6	49	454	952	—	100	215	282	—	0	-10	-18	—	0.447
72	93	95	1	0.6	49	454	952	—	100	215	282	—	0	-10	-18	—	0.447
72	93	95	1	0.6	49	325	642	—	56	110	143	—	0	-13	-23	—	0.386
72	93	95	1	0.6	49	325	642	—	56	110	143	—	0	-13	-23	—	0.386
72	93	95	1	0.6	49	422	872	—	93	195	254	—	0	-10	-18	—	0.386
72	93	95	1	0.6	49	422	872	—	93	195	254	—	0	-10	-18	—	0.386
72	93	95	1	0.6	49	130	367	—	54	76	113	—	0	-5	-15	—	0.570
72	93	95	1	0.6	49	141	415	—	60	87	131	—	0	-5	-15	—	0.545
72	93	95	1	0.6	49	141	415	—	60	87	131	—	0	-5	-15	—	0.545
72	93	95	1	0.6	49	399	824	—	89	184	240	—	0	-10	-18	—	0.570
72	93	95	1	0.6	49	454	952	—	100	215	282	—	0	-10	-18	—	0.545
72	93	95	1	0.6	49	454	952	—	100	215	282	—	0	-10	-18	—	0.545
74	111	114	1.5	0.8	219	448	1 069	2 175	71	9							

1. Angular Contact Ball Bearings

Bore Diameter **70mm**

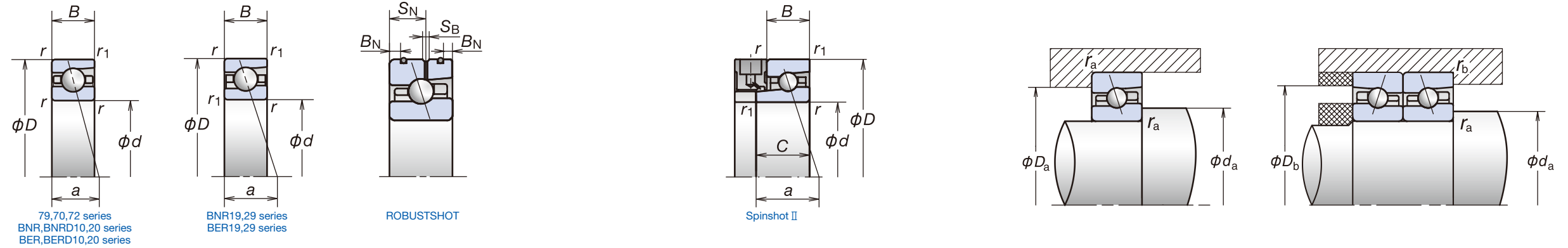

Designation (*)	Boundary Dimensions (*) (mm)								Basic Load Ratings (kN)		Permissible Axial Load (*) (kN)	Contact Angle (°)	Factor f ₀	Effective Load Center (mm) a	Limiting Speeds (*) (min ⁻¹)		
	d	D	B	C	B _N	S _N	S _B	r (min.)	r ₁ (min.)	C _r (Dynamic)					C _{or} (Static)	Grease	Oil
*7914C	70	100	16	—	—	—	—	1	0.6	35.5	27.8	17.3	15	16.4	19.4	13 600	20 600
*7914CSN24	70	100	16	—	—	—	—	1	0.6	35.5	26.6	20.5	15	16.4	19.4	17 700	26 900
*7914A5	70	100	16	—	—	—	—	1	0.6	33.5	26.3	20.3	25	—	27.8	11 800	17 700
*7914A5SN24	70	100	16	—	—	—	—	1	0.6	33.5	25.2	24.1	25	—	27.8	15 300	23 000
*70BNR19E	70	100	16	—	—	—	—	1	0.6	26.8	18.1	26.1	18	10.8	21.8	17 700	25 200
*70BNR19H	70	100	16	—	3.1	9.3	1.4	1	0.6	26.8	17.3	17.1	18	10.8	21.8	21 200	33 000
*70BNR19X	70	100	16	21	3.1	9.3	1.4	1	0.6	42.5	17.3	17.1	18	10.8	21.8	24 800	38 900
*70BER19E	70	100	16	—	—	—	—	1	0.6	25.7	17.3	30.5	25	—	27.8	15 200	21 500
*70BER19H	70	100	16	—	3.1	9.3	1.4	1	0.6	25.7	16.6	20.7	25	—	27.8	18 900	29 500
*70BER19X	70	100	16	21	3.1	9.3	1.4	1	0.6	41.0	16.6	20.7	25	—	27.8	22 400	35 300
*70BNR29EV1V	70	100	19	—	—	—	—	1	0.6	26.8	18.1	26.1	18	10.8	23.3	17 700	—
*70BNR29HV1V	70	100	19	—	—	—	—	1	0.6	26.8	17.3	17.1	18	10.8	23.3	21 200	—
*70BNR29XV1V	70	100	19	—	—	—	—	1	0.6	42.5	17.3	17.1	18	10.8	23.3	24 800	—
*70BER29EV1V	70	100	19	—	—	—	—	1	0.6	25.7	17.3	30.5	25	—	29.3	15 200	—
*70BER29HV1V	70	100	19	—	—	—	—	1	0.6	25.7	16.6	20.7	25	—	29.3	18 900	—
*70BER29XV1V	70	100	19	—	—	—	—	1	0.6	41.0	16.6	20.7	25	—	29.3	22 400	—
*7014C	70	110	20	—	—	—	—	1.1	0.6	59.0	43.0	26.8	15	15.7	22.1	12 800	19 500
*7014CSN24	70	110	20	—	—	—	—	1.1	0.6	59.0	41.5	31.8	15	15.7	22.1	16 700	25 400
*7014A5	70	110	20	—	—	—	—	1.1	0.6	56.0	41.0	32.0	25	—	31.0	11 200	16 700
*7014A5SN24	70	110	20	—	—	—	—	1.1	0.6	56.0	39.0	38.0	25	—	31.0	14 500	21 700
*7014A	70	110	20	—	—	—	—	1.1	0.6	53.5	39.5	24.6	30	—	36.0	8 400	11 200
*70BNR10E	70	110	20	—	—	—	—	1.1	0.6	28.1	19.8	28.6	18	10.9	24.5	16 700	23 800
*70BNR10H	70	110	20	—	4.0	11.6	1.4	1.1	0.6	28.1	18.9	18.8	18	10.9	24.5	20 000	31 200
*70BNR10X	70	110	20	25	4.0	11.6	1.4	1.1	0.6	44.5	18.9	18.8	18	10.9	24.5	23 400	36 700
*70BER10E	70	110	20	—	—	—	—	1.1	0.6	26.9	18.9	33.5	25	—	30.8	14 400	20 300
*70BER10H	70	110	20	—	4.0	11.6	1.4	1.1	0.6	26.9	18.1	22.6	25	—	30.8	17 800	27 800
*70BER10X	70	110	20	25	4.0	11.6	1.4	1.1	0.6	42.5	18.1	22.6	25	—	30.8	21 200	33 400
*70BNRD10J	70	110	20	—	4.0	11.6	1.4	1.1	0.6	52.0	21.8	21.1	18	8.1	24.6	20 000	31 200
*70BNRD10X	70	110	20	25	4.0	11.6	1.4	1.1	0.6	65.5	21.8	21.1	18	8.1	24.6	23 400	36 700
*70BERD10J	70	110	20	—	4.0	11.6	1.4	1.1	0.6	50.0	20.9	25.9	25	—	31.0	17 800	27 800
*70BERD10X	70	110	20	25	4.0	11.6	1.4	1.1	0.6	63.0	20.9	25.9	25	—	31.0	21 200	33 400
*70BNR20EV1V	70	110	24	—	—	—	—	1.1	0.6	28.1	19.8	28.6	18	10.9	26.5	16 700	—
*70BNR20HV1V	70	110	24	—	—	—	—	1.1	0.6	28.1	18.9	18.8	18	10.9	26.5	20 000	—
*70BNR20XV1V	70	110	24	—	—	—	—	1.1	0.6	44.5	18.9	18.8	18	10.9	26.5	23 400	—
*70BER20EV1V	70	110	24	—	—	—	—	1.1	0.6	26.9	18.9	33.5	25	—	32.8	14 400	—
*70BER20HV1V	70	110	24	—	—	—	—	1.1	0.6	26.9	18.1	22.6	25	—	32.8	17 800	—
*70BER20XV1V	70	110	24	—	—	—	—	1.1	0.6	42.5	18.1	22.6	25	—	32.8	21 200	—
7214C	70	125	24	—	—	—	—	1.5	1	100	64.5	43.0	15	14.6	25.1	11 800	18 000
7214CSN24	70	125	24	—	—	—	—	1.5	1	100	61.5	51.3	15	14.6	25.1	15 400	23 400
7214A5	70	125	24	—	—	—	—	1.5	1	95.5	61.5	49.5	25	—	34.7	10 300	15 400
7214A5SN24	70	125	24	—	—	—	—	1.5	1	95.5	59.0	59.0	25	—	34.7	13 400	20 000
7214A	70	125	24	—	—	—	—	1.5	1	92.0	59.5	38.0	30	—	40.1	7 700	10 300

Abutment and Fillet Dimensions (mm)					Preload (DB and DF Arrangement) (N)				Axial Rigidity (DB and DF Arrangement) (N/μm)				Measured Axial Clearance (μm)				Mass (kg) (approx.)
d _a (min.)	D _a (max.)	D _b (max.)	r _a (max.)	r _b (max.)	EL	L	M	H	EL	L	M	H	EL	L	M	H	
76	94	95	1	0.5	101	205	503	1 004	59	79	119	168	-4	-10	-22	-36	0.338
76	94	95	1	0.5	108	227	571	1 155	67	91	138	196	-4	-10	-22	-36	0.301
76	94	95	1	0.5	137	298	676	1 404	138	182	248	334	-3	-7	-14	-24	0.341
76	94	95	1	0.5	150	336	777	1 633	158	212	291	392	-3	-7	-14	-24	0.304
76	94	95	1	0.5	49	181	367	—	51	80	105	—	0	-8	-16	—	0.328
76	94	95	1	0.5	49	200	415	—	57	93	122	—	0	-8	-16	—	0.292
76	94	95	1	0.5	49	200	415	—	57	93	122	—	0	-8	-16	—	0.292
76	94	95	1	0.5	49	292	604	—	84	154	201	—	0	-8	-15	—	0.328
76	94	95	1	0.5	49	329	693	—	94	180	235	—	0	-8	-15	—	0.292
76	94	95	1	0.5	49	329	693	—	94	180	235	—	0	-8	-15	—	0.292
76	94	95	1	0.5	49	181	367	—	51	80	105	—	0	-8	-16	—	0.381
76	94	95	1	0.5	49	200	415	—	57	93	122	—	0	-8	-16	—	0.344
76	94	95	1	0.5	49	200	415	—	57	93	122	—	0	-8	-16	—	0.344
76	94	95	1	0.5	49	292	604	—	84	154	201	—	0	-8	-15	—	0.381
76	94	95	1	0.5	49	329	693	—	94	180	235	—	0	-8	-15	—	0.344
76	94	95	1	0.5	49	329	693	—	94	180	235	—	0	-8	-15	—	0.344
77	103	105	1	0.6	148	285	732	1 460	68	89	135	190	-7	-14	-30	-48	0.606
77	103	105	1	0.6	161	319	839	1 692	78	103	158	222	-7	-14	-30	-48	0.525
77	103	105	1	0.6	255	500	1 080	2 196	172	220	294	391	-6	-11	-20	-33	0.625
77	103	105	1	0.6	285	572	1 252	2 566	200	257	346	461	-6	-11	-20	-33	0.544
77	103	105	1	0.6	49	278	1 038	2 106	130	231	370	482	0	-5	-15	-25	0.613
77	103	105	1	0.6	49	235	509	—	53	93	126	—	0	-10	-20	—	0.645
77	103	105	1	0.6	49	262	582	—	60	108	147	—	0	-10	-20	—	0.605
77	103	105	1	0.6	49	262	582	—	60	108	147	—	0	-10	-20	—	0.605
77	103	105	1	0.6	49	396	815	—	89	181	236	—	0	-10	-18	—	0.645
77	103	105	1	0.6	49	451	942	—	100	212	278	—	0	-10	-18	—	0.605
77	103	105	1	0.6	49	451	942	—	100	212	278	—	0	-10	-18	—	0.605
77	103	105	1	0.6	49	387	840	—	57	118	160	—	0	-15	-28	—	0.534
77	103	105	1	0.6	49	387	840	—	57	118	160	—	0	-15	-28	—	0.534
77	103	105	1	0.6	49	533	1 089	—	94	215	278	—	0	-12	-21	—	0.534
77	103	105	1	0.6	49	533	1 089	—	94	215	278	—	0	-12	-21	—	0.534
77	103	105	1	0.6	49	235	509	—	53	93	126	—	0	-10	-20	—	0.764
77	103	105	1	0.6	49	262	582	—	60	108	147	—	0	-10	-20	—	0.724
77	103	105	1	0.6	49	262	582	—	60	108	147	—	0	-10	-20	—	0.724
77	103	105	1	0.6	49	396	815	—	89	181	236	—	0	-10	-18	—	0.764
77	103	105	1	0.6	49	451	942	—	100	212	278	—	0	-10	-18	—	0.724
77	103	105	1	0.6	49	451	942	—	100	212	278	—	0	-10	-18	—	0.724
79	116	119	1.5	0													

1. Angular Contact Ball Bearings

Bore Diameter **75mm**

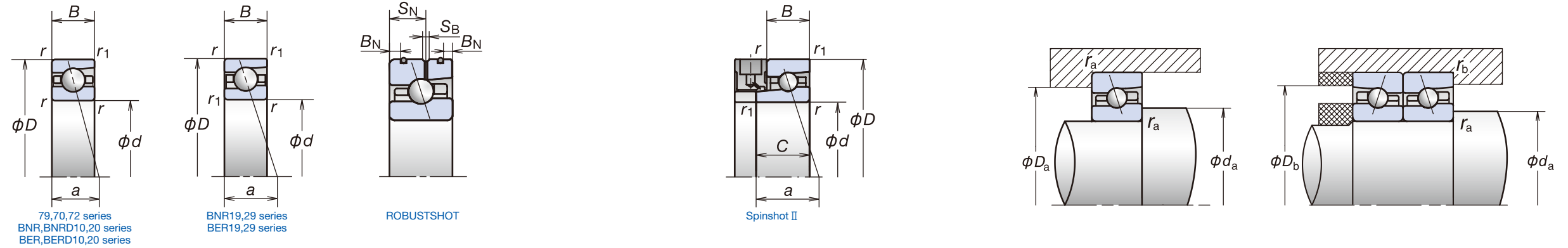

Designation (*)	Boundary Dimensions (*) (mm)								Basic Load Ratings (kN)		Permissible Axial Load (*) (kN)	Contact Angle (°)	Factor f_0	Effective Load Center (mm) a	Limiting Speeds (*) (min ⁻¹)		
	d	D	B	C	B_N	S_N	S_B	r (min.)	r_1 (min.)	C_r (Dynamic)					C_{or} (Static)	Grease	Oil
*7915C	75	105	16	—	—	—	—	1	0.6	36.0	29.3	18.0	15	16.6	20.1	12 800	19 500
*7915CSN24	75	105	16	—	—	—	—	1	0.6	36.0	28.0	21.3	15	16.6	20.1	16 700	25 400
*7915A5	75	105	16	—	—	—	—	1	0.6	34.0	27.7	21.2	25	—	29.0	11 200	16 700
*7915A5SN24	75	105	16	—	—	—	—	1	0.6	34.0	26.5	25.1	25	—	29.0	14 500	21 700
*75BNR19E	75	105	16	—	—	—	—	1	0.6	27.3	19.0	27.5	18	10.9	22.6	16 700	23 800
*75BNR19H	75	105	16	—	3.1	9.3	1.4	1	0.6	27.3	18.2	18.0	18	10.9	22.6	20 000	31 200
*75BNR19X	75	105	16	21	3.1	9.3	1.4	1	0.6	43.5	18.2	18.0	18	10.9	22.6	23 400	36 700
*75BER19E	75	105	16	—	—	—	—	1	0.6	26.1	18.2	32.5	25	—	29.0	14 400	20 300
*75BER19H	75	105	16	—	3.1	9.3	1.4	1	0.6	26.1	17.4	21.7	25	—	29.0	17 800	27 800
*75BER19X	75	105	16	21	3.1	9.3	1.4	1	0.6	41.5	17.4	21.7	25	—	29.0	21 200	33 400
*75BNR29EV1V	75	105	19	—	—	—	—	1	0.6	27.3	19.0	27.5	18	10.9	24.1	16 700	—
*75BNR29HV1V	75	105	19	—	—	—	—	1	0.6	27.3	18.2	18.0	18	10.9	24.1	20 000	—
*75BNR29XV1V	75	105	19	—	—	—	—	1	0.6	43.5	18.2	18.0	18	10.9	24.1	23 400	—
*75BER29EV1V	75	105	19	—	—	—	—	1	0.6	26.1	18.2	32.5	25	—	30.5	14 400	—
*75BER29HV1V	75	105	19	—	—	—	—	1	0.6	26.1	17.4	21.7	25	—	30.5	17 800	—
*75BER29XV1V	75	105	19	—	—	—	—	1	0.6	41.5	17.4	21.7	25	—	30.5	21 200	—
*7015C	75	115	20	—	—	—	—	1.1	0.6	60.5	45.5	28.1	15	15.9	22.7	12 200	18 500
*7015CSN24	75	115	20	—	—	—	—	1.1	0.6	60.5	44.0	33.3	15	15.9	22.7	15 800	24 000
*7015A5	75	115	20	—	—	—	—	1.1	0.6	57.0	43.5	33.5	25	—	32.1	10 600	15 800
*7015A5SN24	75	115	20	—	—	—	—	1.1	0.6	57.5	41.5	40.0	25	—	32.1	13 700	20 600
*7015A	75	115	20	—	—	—	—	1.1	0.6	55.0	41.5	25.9	30	—	37.4	7 900	10 600
*75BNR10E	75	115	20	—	—	—	—	1.1	0.6	28.5	20.7	30.0	18	11.0	25.3	15 800	22 600
*75BNR10H	75	115	20	—	4.0	11.6	1.4	1.1	0.6	28.5	19.8	19.7	18	11.0	25.3	19 000	29 500
*75BNR10X	75	115	20	27	4.0	11.6	1.4	1.1	0.6	45.0	19.8	19.7	18	11.0	25.3	22 200	34 800
*75BER10E	75	115	20	—	—	—	—	1.1	0.6	27.2	19.8	35.0	25	—	31.9	13 600	19 200
*75BER10H	75	115	20	—	4.0	11.6	1.4	1.1	0.6	27.2	19.0	23.7	25	—	31.9	16 900	26 400
*75BER10X	75	115	20	27	4.0	11.6	1.4	1.1	0.6	43.0	19.0	23.7	25	—	31.9	20 000	31 600
*75BNRD10J	75	115	20	—	4.0	11.6	1.4	1.1	0.6	53.5	23.1	22.4	18	8.2	25.4	19 000	29 500
*75BNRD10X	75	115	20	27	4.0	11.6	1.4	1.1	0.6	67.0	23.1	22.4	18	8.2	25.4	22 200	34 800
*75BERD10J	75	115	20	—	4.0	11.6	1.4	1.1	0.6	51.5	22.2	27.4	25	—	32.2	16 900	26 400
*75BERD10X	75	115	20	27	4.0	11.6	1.4	1.1	0.6	64.5	22.2	27.4	25	—	32.2	20 000	31 600
*75BNR20EV1V	75	115	24	—	—	—	—	1.1	0.6	28.5	20.7	30.0	18	11.0	27.3	15 800	—
*75BNR20HV1V	75	115	24	—	—	—	—	1.1	0.6	28.5	19.8	19.7	18	11.0	27.3	19 000	—
*75BNR20XV1V	75	115	24	—	—	—	—	1.1	0.6	45.0	19.8	19.7	18	11.0	27.3	22 200	—
*75BER20EV1V	75	115	24	—	—	—	—	1.1	0.6	27.2	19.8	35.0	25	—	33.9	13 600	—
*75BER20HV1V	75	115	24	—	—	—	—	1.1	0.6	27.2	19.0	23.7	25	—	33.9	16 900	—
*75BER20XV1V	75	115	24	—	—	—	—	1.1	0.6	43.0	19.0	23.7	25	—	33.9	20 000	—
7215C	75	130	25	—	—	—	—	1.5	1	104	70.0	46.0	15	14.8	26.2	11 300	17 100
7215CSN24	75	130	25	—	—	—	—	1.5	1	104	67.0	54.9	15	14.8	26.2	14 700	22 300
7215A5	75	130	25	—	—	—	—	1.5	1	99.5	66.5	53.0	25	—	36.4	9 800	14 700
7215A5SN24	75	130	25	—	—	—	—	1.5	1	99.5	63.5	62.7	25	—	36.4	12 700	19 100
7215A	75	130	25	—	—	—	—	1.5	1	95.5	64.5	40.5	30	—	42.1	7 400	9 800

Abutment and Fillet Dimensions (mm)					Preload (DB and DF Arrangement) (N)				Axial Rigidity (DB and DF Arrangement) (N/μm)				Measured Axial Clearance (μm)				Mass (kg) (approx.)
d_a (min.)	D_a (max.)	D_b (max.)	r_a (max.)	r_b (max.)	EL	L	M	H	EL	L	M	H	EL	L	M	H	
81	99	100	1	0.5	103	190	489	997	61	79	120	171	-4	-9	-21	-35	0.358
81	99	100	1	0.5	109	210	555	1 147	70	91	140	199	-4	-9	-21	-35	0.319
81	99	100	1	0.5	140	307	765	1 458	142	189	268	347	-3	-7	-15	-24	0.355
81	99	100	1	0.5	153	346	882	1 696	164	220	314	409	-3	-7	-15	-24	0.316
81	99	100	1	0.5	49	185	464	—	52	83	118	—	0	-8	-19	—	0.348
81	99	100	1	0.5	49	205	528	—	58	96	138	—	0	-8	-19	—	0.310
81	99	100	1	0.5	49	205	528	—	58	96	138	—	0	-8	-19	—	0.310
81	99	100	1	0.5	49	301	625	—	87	160	209	—	0	-8	-15	—	0.348
81	99	100	1	0.5	49	339	718	—	97	187	245	—	0	-8	-15	—	0.310
81	99	100	1	0.5	49	339	718	—	97	187	245	—	0	-8	-15	—	0.310
81	99	100	1	0.5	49	185	464	—	52	83	118	—	0	-8	-19	—	0.403
81	99	100	1	0.5	49	205	528	—	58	96	138	—	0	-8	-19	—	0.365
81	99	100	1	0.5	49	205	528	—	58	96	138	—	0	-8	-19	—	0.365
81	99	100	1	0.5	49	301	625	—	87	160	209	—	0	-8	-15	—	0.403
81	99	100	1	0.5	49	339	718	—	97	187	245	—	0	-8	-15	—	0.365
81	99	100	1	0.5	49	339	718	—	97	187	245	—	0	-8	-15	—	0.365
82	108	110	1	0.6	151	294	796	1 573	70	92	144	202	-7	-14	-31	-49	0.643
82	108	110	1	0.6	165	330	915	1 824	81	107	168	236	-7	-14	-31	-49	0.557
82	108	110	1	0.6	263	519	1 204	2 399	179	230	316	418	-6	-11	-21	-34	0.652
82	108	110	1	0.6	295	594	1 398	2 806	209	269	372	493	-6	-11	-21	-34	0.566
82	108	110	1	0.6	49	288	1 083	2 202	135	241	387	506	0	-5	-15	-25	0.650
82	108	110	1	0.6	49	240	525	—	55	96	131	—	0	-10	-20	—	0.679
82	108	110	1	0.6	49	269	600	—	61	112	153	—	0	-10	-20	—	0.638
82	108	110	1	0.6	49	269	600	—	61	112	153	—	0	-10	-20	—	0.638
82	108	110	1	0.6	49	506	1 034	—	91	203	265	—	0	-12	-21	—	0.679
82	108	110	1	0.6	49	579	1 199	—	103	238	311	—	0	-12	-21	—	0.638
82	108	110	1	0.6	49	579	1 199	—	103	238	311	—	0	-12	-21	—	0.638
82	108	110	1	0.6	49	432	875	—	58	127	167	—	0	-16	-28	—	0.557
82	108	110	1	0.6	49	432	875	—	58	127	167	—	0	-16	-28	—	0.557
82	108	110	1	0.6	49	554	1 137	—	97	225	291	—	0	-12	-21	—	0.557
82	108	110	1	0.6	49	554	1 137	—	97	225	291	—	0	-12	-21	—	0.557
82	108	110	1	0.6	49	240	525	—	55	96	131	—	0	-10	-20	—	0.806
82	108	110	1	0.6	49	269	600	—	61	112	153	—	0	-10	-20	—	0.764
82	108	110	1	0.6	49	269	600	—	61	112	153	—	0	-10	-20	—	0.764
82	108	110	1	0.6	49	506	1 034	—	91	203	265	—	0	-12	-21	—	0.806
82	108	110	1	0.6	49	579	1 199	—	103	238	311	—	0	-12	-21	—	0.764
82	108	110	1	0.6	49	579	1 199	—	103	238	311	—	0	-12	-21	—	0.764
84	121	124	1.5														

1. Angular Contact Ball Bearings

Bore Diameter **80mm**

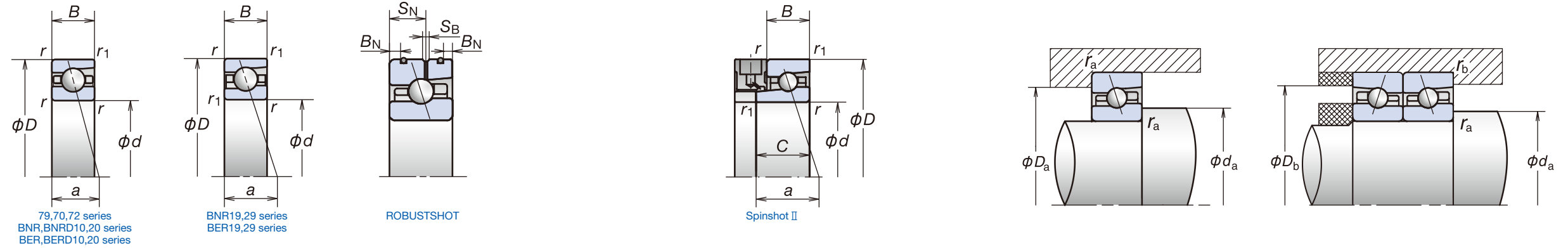

Designation (*)	Boundary Dimensions (*) (mm)							Basic Load Ratings (kN)		Permissible Axial Load (*) (kN)	Contact Angle (°)	Factor f _o	Effective Load Center (mm) a	Limiting Speeds (*) (min ⁻¹)			
	d	D	B	C	B _N	S _N	S _B	r (min.)	r ₁ (min.)					C _r (Dynamic)	C _{or} (Static)	Grease	Oil
*7916C	80	110	16	—	—	—	—	1	0.6	36.5	30.5	18.7	15	16.7	20.7	12 200	18 500
*7916CSN24	80	110	16	—	—	—	—	1	0.6	36.5	29.4	22.2	15	16.7	20.7	15 800	24 000
*7916A5	80	110	16	—	—	—	—	1	0.6	34.5	29.0	22.1	25	—	30.2	10 600	15 800
*7916A5SN24	80	110	16	—	—	—	—	1	0.6	34.5	27.8	26.2	25	—	30.2	13 700	20 600
*80BNR19E	80	110	16	—	—	—	—	1	0.6	27.7	19.9	28.9	18	11.0	23.4	15 800	22 600
*80BNR19H	80	110	16	—	3.1	9.3	1.4	1	0.6	27.7	19.1	18.9	18	11.0	23.4	19 000	29 500
*80BNR19X	80	110	16	21	3.1	9.3	1.4	1	0.6	44.0	19.1	18.9	18	11.0	23.4	22 200	34 800
*80BER19E	80	110	16	—	—	—	—	1	0.6	26.5	19.1	34.0	25	—	30.2	13 600	19 200
*80BER19H	80	110	16	—	3.1	9.3	1.4	1	0.6	26.5	18.3	22.8	25	—	30.2	16 900	26 400
*80BER19X	80	110	16	21	3.1	9.3	1.4	1	0.6	42.0	18.3	22.8	25	—	30.2	20 000	31 600
*80BNR29EV1V	80	110	19	—	—	—	—	1	0.6	27.7	19.9	28.9	18	11.0	24.9	15 800	—
*80BNR29HV1V	80	110	19	—	—	—	—	1	0.6	27.7	19.1	18.9	18	11.0	24.9	19 000	—
*80BNR29XV1V	80	110	19	—	—	—	—	1	0.6	44.0	19.1	18.9	18	11.0	24.9	22 200	—
*80BER29EV1V	80	110	19	—	—	—	—	1	0.6	26.5	19.1	34.0	25	—	31.7	13 600	—
*80BER29HV1V	80	110	19	—	—	—	—	1	0.6	26.5	18.3	22.8	25	—	31.7	16 900	—
*80BER29XV1V	80	110	19	—	—	—	—	1	0.6	42.0	18.3	22.8	25	—	31.7	20 000	—
*7016C	80	125	22	—	—	—	—	1.1	0.6	74.0	55.5	34.5	15	15.7	24.7	11 300	17 100
*7016CSN24	80	125	22	—	—	—	—	1.1	0.6	73.5	52.5	40.9	15	15.7	24.7	14 700	22 300
*7016A5	80	125	22	—	—	—	—	1.1	0.6	70.0	52.5	41.0	25	—	34.9	9 800	14 700
*7016A5SN24	80	125	22	—	—	—	—	1.1	0.6	69.5	50.0	48.3	25	—	34.9	12 700	19 100
*7016A	80	125	22	—	—	—	—	1.1	0.6	67.5	50.5	31.5	30	—	40.6	7 400	9 800
*80BNR10E	80	125	22	—	—	—	—	1.1	0.6	33.5	24.5	35.5	18	10.9	27.5	14 700	20 900
*80BNR10H	80	125	22	—	4.7	12.2	2.2	1.1	0.6	33.5	23.5	23.4	18	10.9	27.5	17 600	27 400
*80BNR10X	80	125	22	27	4.7	12.2	2.2	1.1	0.6	53.0	23.5	23.4	18	10.9	27.5	20 500	32 200
*80BER10E	80	125	22	—	—	—	—	1.1	0.6	32.0	23.5	42.0	25	—	34.6	12 600	17 800
*80BER10H	80	125	22	—	4.7	12.2	2.2	1.1	0.6	32.0	22.5	28.2	25	—	34.6	15 700	24 400
*80BER10X	80	125	22	27	4.7	12.2	2.2	1.1	0.6	50.5	22.5	28.2	25	—	34.6	18 600	29 300
*80BNRD10J	80	125	22	—	4.7	12.2	2.2	1.1	0.6	65.0	28.0	27.3	18	8.1	27.7	17 600	27 400
*80BNRD10X	80	125	22	27	4.7	12.2	2.2	1.1	0.6	82.0	28.0	27.3	18	8.1	27.7	20 500	32 200
*80BERD10J	80	125	22	—	4.7	12.2	2.2	1.1	0.6	62.5	27.0	33.5	25	—	34.9	15 700	24 400
*80BERD10X	80	125	22	27	4.7	12.2	2.2	1.1	0.6	79.0	27.0	33.5	25	—	34.9	18 600	29 300
*80BNR20EV1V	80	125	27	—	—	—	—	1.1	0.6	33.5	24.5	35.5	18	10.9	30.0	14 700	—
*80BNR20HV1V	80	125	27	—	—	—	—	1.1	0.6	33.5	23.5	23.4	18	10.9	30.0	17 600	—
*80BNR20XV1V	80	125	27	—	—	—	—	1.1	0.6	53.0	23.5	23.4	18	10.9	30.0	20 500	—
*80BER20EV1V	80	125	27	—	—	—	—	1.1	0.6	32.0	23.5	42.0	25	—	37.1	12 600	—
*80BER20HV1V	80	125	27	—	—	—	—	1.1	0.6	32.0	22.5	28.2	25	—	37.1	15 700	—
*80BER20XV1V	80	125	27	—	—	—	—	1.1	0.6	50.5	22.5	28.2	25	—	37.1	18 600	—
7216C	80	140	26	—	—	—	—	2	1	117	77.5	54.5	15	14.7	27.7	10 500	16 000
7216CSN24	80	140	26	—	—	—	—	2	1	117	73.5	64.5	15	14.7	27.7	13 700	20 800
7216A5	80	140	26	—	—	—	—	2	1	111	74.0	62.0	25	—	38.6	9 100	13 700
7216A5SN24	80	140	26	—	—	—	—	2	1	111	70.5	73.5	25	—	38.6	11 900	17 800
7216A	80	140	26	—	—	—	—	2	1	107	71.5	47.5	30	—	44.8	6 900	9 100

Abutment and Fillet Dimensions (mm)					Preload (DB and DF Arrangement) (N)				Axial Rigidity (DB and DF Arrangement) (N/μm)				Measured Axial Clearance (μm)				Mass (kg) (approx.)
d _a (min.)	D _a (max.)	D _b (max.)	r _a (max.)	r _b (max.)	EL	L	M	H	EL	L	M	H	EL	L	M	H	
86	104	105	1	0.5	104	195	503	986	63	81	125	173	-4	-9	-21	-34	0.377
86	104	105	1	0.5	111	215	573	1 136	72	94	145	202	-4	-9	-21	-34	0.337
86	104	105	1	0.5	182	366	792	1 603	160	207	278	370	-4	-8	-15	-25	0.381
86	104	105	1	0.5	201	415	913	1 867	186	242	326	436	-4	-8	-15	-25	0.341
86	104	105	1	0.5	49	190	478	—	53	86	123	—	0	-8	-19	—	0.366
86	104	105	1	0.5	49	210	545	—	60	99	143	—	0	-8	-19	—	0.326
86	104	105	1	0.5	49	210	545	—	60	99	143	—	0	-8	-19	—	0.326
86	104	105	1	0.5	49	309	646	—	89	166	217	—	0	-8	-15	—	0.366
86	104	105	1	0.5	49	349	743	—	100	194	254	—	0	-8	-15	—	0.326
86	104	105	1	0.5	49	349	743	—	100	194	254	—	0	-8	-15	—	0.326
86	104	105	1	0.5	49	190	478	—	53	86	123	—	0	-8	-19	—	0.425
86	104	105	1	0.5	49	210	545	—	60	99	143	—	0	-8	-19	—	0.385
86	104	105	1	0.5	49	210	545	—	60	99	143	—	0	-8	-19	—	0.385
86	104	105	1	0.5	49	309	646	—	89	166	217	—	0	-8	-15	—	0.425
86	104	105	1	0.5	49	349	743	—	100	194	254	—	0	-8	-15	—	0.385
86	104	105	1	0.5	49	349	743	—	100	194	254	—	0	-8	-15	—	0.385
87	118	120	1	0.6	202	382	921	1 880	78	102	151	215	-6	-14	-31	-52	0.855
87	118	120	1	0.6	215	422	1 045	2 162	89	118	176	251	-6	-14	-31	-52	0.736
87	118	120	1	0.6	345	624	1 513	2 903	198	246	345	448	-6	-11	-23	-37	0.880
87	118	120	1	0.6	381	704	1 744	3 377	229	286	404	528	-6	-11	-23	-37	0.761
87	118	120	1	0.6	98	752	1 762	3 060	170	340	464	573	0	-10	-20	-30	0.864
87	118	120	1	0.6	98	327	611	—	72	111	141	—	0	-10	-19	—	0.921
87	118	120	1	0.6	98	359	688	—	80	127	164	—	0	-10	-19	—	0.867
87	118	120	1	0.6	98	359	688	—	80	127	164	—	0	-10	-19	—	0.867
87	118	120	1	0.6	98	623	1 272	—	118	225	292	—	0	-12	-22	—	0.921
87	118	120	1	0.6	98	704	1 461	—	133	262	343	—	0	-12	-22	—	0.867
87	118	120	1	0.6	98	704	1 461	—	133	262	343	—	0	-12	-22	—	0.867
87	118	120	1	0.6	98	499	1 051	—	75	135	180	—	0	-15	-29	—	0.748
87	118	120	1	0.6	98	499	1 051	—	75	135	180	—	0	-15	-29	—	0.748
87	118	120	1	0.6	98	663	1 437	—	125	242	319	—	0	-12	-23	—	0.748
87	118	120	1	0.6	98	663	1 437	—	125	242	319	—	0	-12	-23	—	0.748
87	118	120	1	0.6	98	327	611	—	72	111	141	—	0	-10	-19	—	1.12
87	118	120	1	0.6	98	359	688	—	80	127	164	—	0	-10	-19	—	1.06
87	118	120	1	0.6	98	359	688	—	80	127	164	—	0	-10	-19	—	1.06
87	118	120	1	0.6	98	623	1 272	—	118	225	292	—	0	-12	-22	—	1.12
87	118	120	1	0.6	98	704	1 461	—	133	262	343	—	0	-12	-22	—	1.06
87	118	120	1	0.6	98	704	1 461	—	133	262	343	—	0	-12	-22	—	1.06
90	130	134	2</														

1. Angular Contact Ball Bearings

Bore Diameter **85mm**

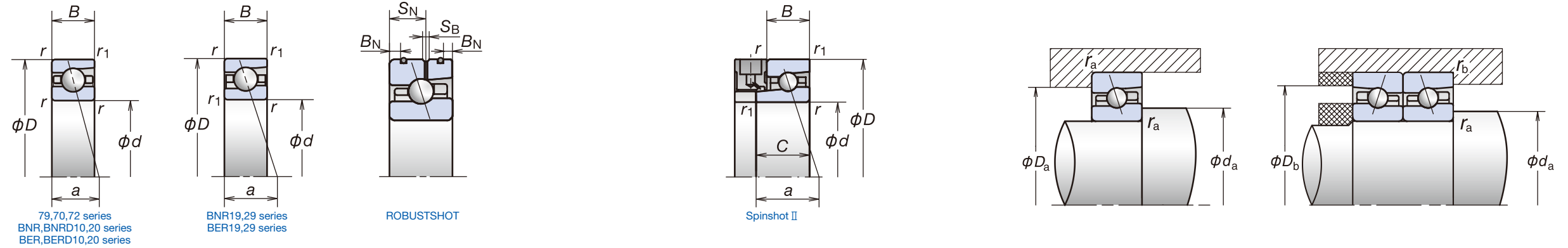

Designation (1)	Boundary Dimensions (2) (mm)							Basic Load Ratings (kN)		Permissible Axial Load (3) (kN)	Contact Angle (4) (°)	Factor f ₀	Effective Load Center (mm) a	Limiting Speeds (5) (min ⁻¹)			
	d	D	B	C	B _N	S _N	S _B	C _r (Dynamic)	C _{or} (Static)					Grease	Oil		
*7917C	85	120	18	—	—	—	—	1.1	0.6	49.0	40.5	25.9	15	16.5	22.7	11 300	17 100
*7917CSN24	85	120	18	—	—	—	—	1.1	0.6	48.5	38.5	30.7	15	16.5	22.7	14 700	22 300
*7917A5	85	120	18	—	—	—	—	1.1	0.6	46.0	38.5	30.0	25	—	32.9	9 800	14 700
*7917A5SN24	85	120	18	—	—	—	—	1.1	0.6	46.0	36.5	35.6	25	—	32.9	12 700	19 100
*85BNR19E	85	120	18	—	—	—	—	1.1	0.6	37.0	26.3	38.0	18	10.8	25.7	14 700	20 900
*85BNR19H	85	120	18	—	4.0	10.4	2.2	1.1	0.6	37.0	25.1	24.8	18	10.8	25.7	17 600	27 400
*85BNR19X	85	120	18	23	4.0	10.4	2.2	1.1	0.6	59.0	25.1	24.8	18	10.8	25.7	20 500	32 200
*85BER19E	85	120	18	—	—	—	—	1.1	0.6	35.5	25.2	35.5	25	—	32.9	12 600	17 800
*85BER19H	85	120	18	—	4.0	10.4	2.2	1.1	0.6	35.5	24.1	30.0	25	—	32.9	15 700	24 400
*85BER19X	85	120	18	23	4.0	10.4	2.2	1.1	0.6	56.0	24.1	30.0	25	—	32.9	18 600	29 300
*85BNR29EV1V	85	120	22	—	—	—	—	1.1	0.6	37.0	26.3	38.0	18	10.8	27.7	14 700	—
*85BNR29HV1V	85	120	22	—	—	—	—	1.1	0.6	37.0	25.1	24.8	18	10.8	27.7	17 600	—
*85BNR29XV1V	85	120	22	—	—	—	—	1.1	0.6	59.0	25.1	24.8	18	10.8	27.7	20 500	—
*85BER29EV1V	85	120	22	—	—	—	—	1.1	0.6	35.5	25.2	35.5	25	—	34.9	12 600	—
*85BER29HV1V	85	120	22	—	—	—	—	1.1	0.6	35.5	24.1	30.0	25	—	34.9	15 700	—
*85BER29XV1V	85	120	22	—	—	—	—	1.1	0.6	56.0	24.1	30.0	25	—	34.9	18 600	—
*7017C	85	130	22	—	—	—	—	1.1	0.6	76.0	58.5	38.0	15	15.9	25.4	10 700	16 300
*7017CSN24	85	130	22	—	—	—	—	1.1	0.6	75.5	55.5	45.0	15	15.9	25.4	14 000	21 300
*7017A5	85	130	22	—	—	—	—	1.1	0.6	71.5	55.5	43.0	25	—	36.1	9 400	14 000
*7017A5SN24	85	130	22	—	—	—	—	1.1	0.6	71.5	53.0	50.9	25	—	36.1	12 100	18 200
*7017A	85	130	22	—	—	—	—	1.1	0.6	69.0	53.5	33.0	30	—	42.0	7 000	9 400
*85BNR10E	85	130	22	—	—	—	—	1.1	0.6	34.0	25.7	37.5	18	11.0	28.5	14 000	20 000
*85BNR10H	85	130	22	—	4.7	12.2	2.2	1.1	0.6	34.0	24.6	24.5	18	11.0	28.5	16 800	26 100
*85BNR10X	85	130	22	27	4.7	12.2	2.2	1.1	0.6	53.5	24.6	24.5	18	11.0	28.5	19 600	30 700
*85BER10E	85	130	22	—	—	—	—	1.1	0.6	32.5	24.6	43.5	25	—	36.1	12 000	17 000
*85BER10H	85	130	22	—	4.7	12.2	2.2	1.1	0.6	32.5	23.6	29.5	25	—	36.1	14 900	23 300
*85BER10X	85	130	22	27	4.7	12.2	2.2	1.1	0.6	51.0	23.6	29.5	25	—	36.1	17 700	28 000
*85BNRD10J	85	130	22	—	4.7	12.2	2.2	1.1	0.6	67.0	29.7	28.9	18	8.2	28.5	16 800	26 100
*85BNRD10X	85	130	22	27	4.7	12.2	2.2	1.1	0.6	84.5	29.7	28.9	18	8.2	28.5	19 600	30 700
*85BERD10J	85	130	22	—	4.7	12.2	2.2	1.1	0.6	64.5	28.5	35.5	25	—	36.1	14 900	23 300
*85BERD10X	85	130	22	27	4.7	12.2	2.2	1.1	0.6	81.0	28.5	35.5	25	—	36.1	17 700	28 000
*85BNR20EV1V	85	130	27	—	—	—	—	1.1	0.6	34.0	25.7	37.5	18	11.0	31.0	14 000	—
*85BNR20HV1V	85	130	27	—	—	—	—	1.1	0.6	34.0	24.6	24.5	18	11.0	31.0	16 800	—
*85BNR20XV1V	85	130	27	—	—	—	—	1.1	0.6	53.5	24.6	24.5	18	11.0	31.0	19 600	—
*85BER20EV1V	85	130	27	—	—	—	—	1.1	0.6	32.5	24.6	43.5	25	—	38.6	12 000	—
*85BER20HV1V	85	130	27	—	—	—	—	1.1	0.6	32.5	23.6	29.5	25	—	38.6	14 900	—
*85BER20XV1V	85	130	27	—	—	—	—	1.1	0.6	51.0	23.6	29.5	25	—	38.6	17 700	—
7217C	85	150	28	—	—	—	—	2	1	135	90.5	60.5	15	14.7	29.7	9 800	14 900
7217CSN24	85	150	28	—	—	—	—	2	1	135	87.0	71.9	15	14.7	29.7	12 800	19 500
7217A5	85	150	28	—	—	—	—	2	1	129	86.5	70.0	25	—	41.4	8 600	12 800
7217A5SN24	85	150	28	—	—	—	—	2	1	129	83.0	83.1	25	—	41.4	11 100	16 600
7217A	85	150	28	—	—	—	—	2	1	124	83.5	53.5	30	—	47.9	6 400	8 600

Abutment and Fillet Dimensions (mm)					Preload (DB and DF Arrangement) (N)				Axial Rigidity (DB and DF Arrangement) (N/μm)				Measured Axial Clearance (μm)				Mass (kg) (approx.)
d _a (min.)	D _a (max.)	D _b (max.)	r _a (max.)	r _b (max.)	EL	L	M	H	EL	L	M	H	EL	L	M	H	
92	113	115	1	0.6	138	307	629	1 281	71	98	135	191	-6	-14	-25	-41	0.534
92	113	115	1	0.6	150	345	719	1 481	81	114	158	224	-6	-14	-25	-41	0.470
92	113	115	1	0.6	227	427	950	1 909	176	222	300	396	-5	-9	-17	-28	0.541
92	113	115	1	0.6	253	486	1 099	2 228	205	259	352	467	-5	-9	-17	-28	0.477
92	113	115	1	0.6	49	193	652	—	55	88	140	—	0	-8	-24	—	0.527
92	113	115	1	0.6	49	214	749	—	61	102	164	—	0	-8	-24	—	0.456
92	113	115	1	0.6	49	214	749	—	61	102	164	—	0	-8	-24	—	0.456
92	113	115	1	0.6	49	317	898	—	91	171	248	—	0	-8	-19	—	0.527
92	113	115	1	0.6	49	358	1 039	—	102	199	292	—	0	-8	-19	—	0.456
92	113	115	1	0.6	49	358	1 039	—	102	199	292	—	0	-8	-19	—	0.456
92	113	115	1	0.6	49	193	652	—	55	88	140	—	0	-8	-24	—	0.617
92	113	115	1	0.6	49	214	749	—	61	102	164	—	0	-8	-24	—	0.554
92	113	115	1	0.6	49	214	749	—	61	102	164	—	0	-8	-24	—	0.554
92	113	115	1	0.6	49	317	898	—	91	171	248	—	0	-8	-19	—	0.617
92	113	115	1	0.6	49	358	1 039	—	102	199	292	—	0	-8	-19	—	0.554
92	113	115	1	0.6	49	358	1 039	—	102	199	292	—	0	-8	-19	—	0.554
92	123	125	1	0.6	205	393	995	1 956	81	106	161	224	-6	-14	-32	-52	0.898
92	123	125	1	0.6	219	434	1 130	2 252	93	122	187	262	-6	-14	-32	-52	0.773
92	123	125	1	0.6	305	646	1 487	2 915	196	257	353	462	-5	-11	-22	-36	0.904
92	123	125	1	0.6	334	729	1 713	3 390	226	299	413	544	-5	-11	-22	-36	0.779
92	123	125	1	0.6	98	780	1 837	3 196	176	355	486	600	0	-10	-20	-30	0.907
92	123	125	1	0.6	98	334	627	—	73	114	146	—	0	-10	-19	—	0.962
92	123	125	1	0.6	98	367	707	—	82	132	170	—	0	-10	-19	—	0.906
92	123	125	1	0.6	98	367	707	—	82	132	170	—	0	-10	-19	—	0.906
92	123	125	1	0.6	98	640	1 311	—	122	232	303	—	0	-12	-22	—	0.962
92	123	125	1	0.6	98	723	1 508	—	136	271	355	—	0	-12	-22	—	0.906
92	123	125	1	0.6	98	723	1 508	—	136	271	355	—	0	-12	-22	—	0.906
92	123	125	1	0.6	98	550	1 092	—	77	144	188	—	0	-16	-29	—	0.778
92	123	125	1	0.6	98	550	1 092	—	77	144	188	—	0	-16	-29	—	0.778
92	123	125	1	0.6	98	750	1 496	—	129	261	334	—	0	-13	-23	—	0.778
92	123	125	1	0.6	98	750	1 496	—	129	261	334	—	0	-13	-23	—	0.778
92	123	125	1	0.6	98	334	627	—	73	114	146	—	0	-10	-19	—	1.16
92	123	125	1	0.6	98	367	707	—	82	132	170	—	0	-10	-19	—	1.11
92	123	125	1	0.6	98	367	707	—	82	132	170	—	0	-10	-19	—	1.11
92	123	125	1	0.6	98	640	1 311	—	122	232	303	—	0	-12	-22	—	1.16
92	123	125	1	0.6	98	723	1 508	—	136	271	355	—	0	-12	-22	—	1.11
92	123	125	1	0.6	98	723	1 508	—	136	271	355	—	0	-12	-22	—	1.11

1. Angular Contact Ball Bearings

Bore Diameter **90 mm**

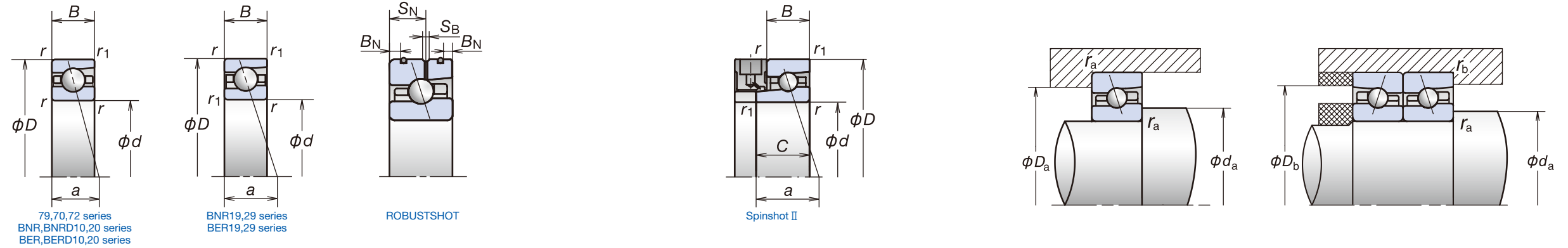

Designation (*)	Boundary Dimensions (*) (mm)							Basic Load Ratings (kN)		Permissible Axial Load (*) (kN)	Contact Angle (°)	Factor f_0	Effective Load Center (mm) a	Limiting Speeds (*) (min ⁻¹)			
	d	D	B	C	B_N	S_N	S_B	r (min.)	r_1 (min.)					C_r (Dynamic)	C_{or} (Static)	Grease	Oil
*7918C	90	125	18	—	—	—	—	1.1	0.6	52.5	46.0	29.1	15	16.6	23.4	10 700	16 300
*7918CSN24	90	125	18	—	—	—	—	1.1	0.6	52.0	43.5	34.6	15	16.6	23.4	14 000	21 300
*7918A5	90	125	18	—	—	—	—	1.1	0.6	49.5	43.5	33.5	25	—	34.1	9 400	14 000
*7918A5SN24	90	125	18	—	—	—	—	1.1	0.6	49.0	41.0	40.0	25	—	34.1	12 100	18 200
*90BNR19E	90	125	18	—	—	—	—	1.1	0.6	39.5	29.7	43.0	18	10.9	26.5	14 000	20 000
*90BNR19H	90	125	18	—	4.0	10.4	2.2	1.1	0.6	39.5	28.5	28.1	18	10.9	26.5	16 800	26 100
*90BNR19X	90	125	18	23	4.0	10.4	2.2	1.1	0.6	63.0	28.5	28.1	18	10.9	26.5	19 600	30 700
*90BER19E	90	125	18	—	—	—	—	1.1	0.6	38.0	28.5	50.5	25	—	34.1	12 000	17 000
*90BER19H	90	125	18	—	4.0	10.4	2.2	1.1	0.6	38.0	27.3	34.0	25	—	34.1	14 900	23 300
*90BER19X	90	125	18	23	4.0	10.4	2.2	1.1	0.6	60.0	27.3	34.0	25	—	34.1	17 700	28 000
*90BNR29EV1V	90	125	22	—	—	—	—	1.1	0.6	39.5	29.7	43.0	18	10.9	28.5	14 000	—
*90BNR29HV1V	90	125	22	—	—	—	—	1.1	0.6	39.5	28.5	28.1	18	10.9	28.5	16 800	—
*90BNR29XV1V	90	125	22	—	—	—	—	1.1	0.6	63.0	28.5	28.1	18	10.9	28.5	19 600	—
*90BER29EV1V	90	125	22	—	—	—	—	1.1	0.6	38.0	28.5	50.5	25	—	36.1	12 000	—
*90BER29HV1V	90	125	22	—	—	—	—	1.1	0.6	38.0	27.3	34.0	25	—	36.1	14 900	—
*90BER29XV1V	90	125	22	—	—	—	—	1.1	0.6	60.0	27.3	34.0	25	—	36.1	17 700	—
*7018C	90	140	24	—	—	—	—	1.5	1	90.5	69.0	44.5	15	15.7	27.4	10 000	15 300
*7018CSN24	90	140	24	—	—	—	—	1.5	1	90.5	66.5	53.2	15	15.7	27.4	13 100	19 900
*7018A5	90	140	24	—	—	—	—	1.5	1	85.5	65.5	52.0	25	—	38.8	8 700	13 100
*7018A5SN24	90	140	24	—	—	—	—	1.5	1	85.5	63.0	62.1	25	—	38.8	11 400	17 000
*7018A	90	140	24	—	—	—	—	1.5	1	82.0	63.5	40.5	30	—	45.2	6 600	8 700
*90BNR10E	90	140	24	—	—	—	—	1.5	1	44.0	33.0	48.0	18	10.9	30.7	13 100	18 700
*90BNR10H	90	140	24	—	5.5	14.5	2.2	1.5	1	44.0	31.5	31.5	18	10.9	30.7	15 700	24 400
*90BNR10X	90	140	24	29	5.5	14.5	2.2	1.5	1	70.0	31.5	31.5	18	10.9	30.7	18 300	28 700
*90BER10E	90	140	24	—	—	—	—	1.5	1	42.0	31.5	56.0	25	—	38.8	11 300	15 900
*90BER10H	90	140	24	—	5.5	14.5	2.2	1.5	1	42.0	30.5	38.0	25	—	38.8	14 000	21 800
*90BER10X	90	140	24	29	5.5	14.5	2.2	1.5	1	67.0	30.5	38.0	25	—	38.8	16 600	26 100
*90BNRD10J	90	140	24	—	5.5	14.5	2.2	1.5	1	79.5	35.0	34.0	18	8.1	30.7	15 700	24 400
*90BNRD10X	90	140	24	29	5.5	14.5	2.2	1.5	1	100	35.0	34.0	18	8.1	30.7	18 300	28 700
*90BERD10J	90	140	24	—	5.5	14.5	2.2	1.5	1	76.5	33.5	41.5	25	—	38.8	14 000	21 800
*90BERD10X	90	140	24	29	5.5	14.5	2.2	1.5	1	96.5	33.5	41.5	25	—	38.8	16 600	26 100
*90BNR20EV1V	90	140	30	—	—	—	—	1.5	1	44.0	33.0	48.0	18	10.9	33.7	13 100	—
*90BNR20HV1V	90	140	30	—	—	—	—	1.5	1	44.0	31.5	31.5	18	10.9	33.7	15 700	—
*90BNR20XV1V	90	140	30	—	—	—	—	1.5	1	70.0	31.5	31.5	18	10.9	33.7	18 300	—
*90BER20EV1V	90	140	30	—	—	—	—	1.5	1	42.0	31.5	56.0	25	—	41.8	11 300	—
*90BER20HV1V	90	140	30	—	—	—	—	1.5	1	42.0	30.5	38.0	25	—	41.8	14 000	—
*90BER20XV1V	90	140	30	—	—	—	—	1.5	1	67.0	30.5	38.0	25	—	41.8	16 600	—
7218C	90	160	30	—	—	—	—	2	1	155	105	72.0	15	14.6	31.7	9 200	14 000
7218CSN24	90	160	30	—	—	—	—	2	1	154	100	85.5	15	14.6	31.7	12 000	18 300
7218A5	90	160	30	—	—	—	—	2	1	147	100	83.5	25	—	44.1	8 000	12 000
7218A5SN24	90	160	30	—	—	—	—	2	1	147	95.5	99.2	25	—	44.1	10 400	15 600
7218A	90	160	30	—	—	—	—	2	1	142	96.5	64.5	30	—	51.1	6 000	8 000

Abutment and Fillet Dimensions (mm)					Preload (DB and DF Arrangement) (N)				Axial Rigidity (DB and DF Arrangement) (N/μm)				Measured Axial Clearance (μm)				Mass (kg) (approx.)
d_a (min.)	D_a (max.)	D_b (max.)	r_a (max.)	r_b (max.)	EL	L	M	H	EL	L	M	H	EL	L	M	H	
97	118	120	1	0.6	153	289	740	1 488	79	102	156	219	-3	-9	-23	-39	0.568
97	118	120	1	0.6	159	314	834	1 703	89	117	180	255	-3	-9	-23	-39	0.496
97	118	120	1	0.6	272	500	1 096	2 184	203	253	341	449	-4	-8	-16	-27	0.560
97	118	120	1	0.6	296	560	1 255	2 531	233	294	399	528	-4	-8	-16	-27	0.488
97	118	120	1	0.6	98	282	711	—	75	109	156	—	0	-8	-21	—	0.552
97	118	120	1	0.6	98	308	804	—	84	125	181	—	0	-8	-21	—	0.480
97	118	120	1	0.6	98	308	804	—	84	125	181	—	0	-8	-21	—	0.480
97	118	120	1	0.6	98	432	977	—	124	206	276	—	0	-8	-17	—	0.552
97	118	120	1	0.6	98	482	1 117	—	139	239	323	—	0	-8	-17	—	0.480
97	118	120	1	0.6	98	482	1 117	—	139	239	323	—	0	-8	-17	—	0.480
97	118	120	1	0.6	98	282	711	—	75	109	156	—	0	-8	-21	—	0.653
97	118	120	1	0.6	98	308	804	—	84	125	181	—	0	-8	-21	—	0.582
97	118	120	1	0.6	98	308	804	—	84	125	181	—	0	-8	-21	—	0.582
97	118	120	1	0.6	98	432	977	—	124	206	276	—	0	-8	-17	—	0.653
97	118	120	1	0.6	98	482	1 117	—	139	239	323	—	0	-8	-17	—	0.582
97	118	120	1	0.6	98	482	1 117	—	139	239	323	—	0	-8	-17	—	0.582
99	131	134	1.5	0.8	247	502	1 187	2 373	87	117	172	241	-8	-18	-37	-60	1.16
99	131	134	1.5	0.8	266	560	1 355	2 741	99	135	200	282	-8	-18	-37	-60	0.994
99	131	134	1.5	0.8	409	779	1 758	3 498	218	275	374	494	-7	-13	-25	-41	1.17
99	131	134	1.5	0.8	454	886	2 031	4 079	252	321	440	582	-7	-13	-25	-41	1.00
99	131	134	1.5	0.8	98	782	2 483	3 977	176	356	543	650	0	-10	-25	-35	1.18
99	131	134	1.5	0.8	98	338	830	—	75	116	164	—	0	-10	-24	—	1.24
99	131	134	1.5	0.8	98	372	943	—	83	134	191	—	0	-10	-24	—	1.16
99	131	134	1.5	0.8	98	372	943	—	83	134	191	—	0	-10	-24	—	1.16
99	131	134	1.5	0.8	98	653	1 339	—	124	238	309	—	0	-12	-22	—	1.24
99	131	134	1.5	0.8	98	739	1 541	—	139	277	362	—	0	-12	-22	—	1.16
99	131	134	1.5	0.8	98	739	1 541	—	139	277	362	—	0	-12	-22	—	1.16
99	131	134	1.5	0.8	98	621	1 325	—	77	150	201	—	0	-18	-34	—	1.01
99	131	134	1.5	0.8	98	621	1 325	—	77	150	201	—	0	-18	-34	—	1.01
99	131	134	1.5	0.8	98	883	1 748	—	129	275	352	—	0	-15	-26	—	1.01
99	131	134	1.5	0.8	98	883	1 748	—	129	275	352	—	0	-15	-26	—	1.01
99	131	134	1.5	0.8	98	338	830	—	75	116	164	—	0	-10	-24	—	1.52
99	131	134	1.5	0.8	98	372	943	—	83	134	191	—	0	-10	-24	—	1.44
99	131	134	1.5	0.8	98	372	943	—	83	134	191	—	0	-10	-24	—	1.44
99	131	134	1.5	0.8	98	653	1 339	—	124	238	309	—	0	-12	-22	—	1.52
99	131	134	1.5	0.8	98	739	1 541	—	139	277	362	—	0	-12	-22	—	1.44
99	131	134	1.5	0.8	98	739	1 541	—	139	277	362	—	0	-12			

1. Angular Contact Ball Bearings

Bore Diameter **95 mm**

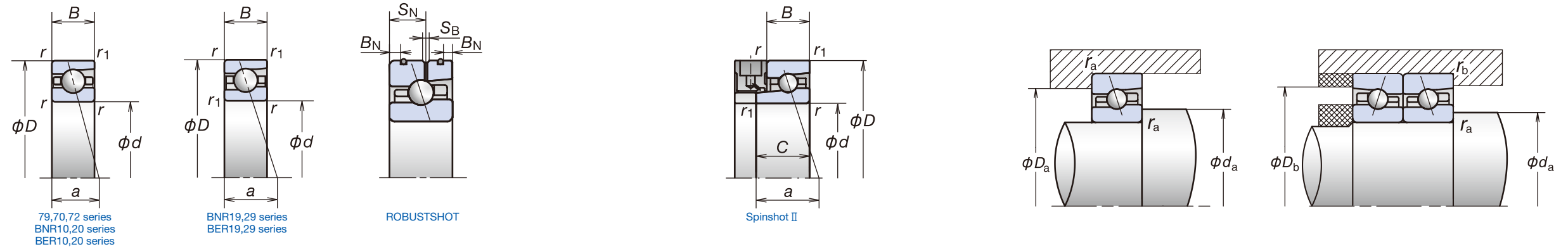

Designation (*)	Boundary Dimensions (°) (mm)								Basic Load Ratings (kN)		Permissible Axial Load (°) (kN)	Contact Angle (°)	Factor f_0	Effective Load Center (mm) a	Limiting Speeds (°) (min ⁻¹)		
	d	D	B	C	B_N	S_N	S_B	r (min.)	r_1 (min.)	C_r (Dynamic)					C_{or} (Static)	Grease	Oil
*7919C	95	130	18	—	—	—	—	1.1	0.6	53.0	48.0	30.0	15	16.7	24.1	10 300	15 600
*7919CSN24	95	130	18	—	—	—	—	1.1	0.6	53.0	45.5	35.8	15	16.7	24.1	13 400	20 300
*7919A5	95	130	18	—	—	—	—	1.1	0.6	50.0	45.5	35.0	25	—	35.2	8 900	13 400
*7919A5SN24	95	130	18	—	—	—	—	1.1	0.6	50.0	43.0	41.5	25	—	35.2	11 600	17 400
95BNR19E	95	130	18	—	—	—	—	1.1	0.6	40.0	31.0	50.0	18	10.9	27.3	13 400	19 100
95BNR19H	95	130	18	—	4.0	10.4	2.2	1.1	0.6	40.0	29.7	32.5	18	10.9	27.3	16 000	24 900
95BNR19X	95	130	18	23	4.0	10.4	2.2	1.1	0.6	64.0	29.7	32.5	18	10.9	27.3	18 700	29 400
95BER19E	95	130	18	—	—	—	—	1.1	0.6	38.5	29.7	58.5	25	—	35.2	11 500	16 200
95BER19H	95	130	18	—	4.0	10.4	2.2	1.1	0.6	38.5	28.5	39.5	25	—	35.2	14 300	22 300
95BER19X	95	130	18	23	4.0	10.4	2.2	1.1	0.6	61.0	28.5	39.5	25	—	35.2	16 900	26 700
7019C	95	145	24	—	—	—	—	1.5	1	92.5	73.0	47.0	15	15.9	28.1	9 600	14 600
7019CSN24	95	145	24	—	—	—	—	1.5	1	93.0	70.5	55.8	15	15.9	28.1	12 500	19 000
7019A5	95	145	24	—	—	—	—	1.5	1	87.5	69.5	52.5	25	—	40.0	8 400	12 500
7019A5SN24	95	145	24	—	—	—	—	1.5	1	88.0	66.5	62.7	25	—	40.0	10 900	16 300
7019A	95	145	24	—	—	—	—	1.5	1	84.0	67.0	40.5	30	—	46.6	6 300	8 400
95BNR10E	95	145	24	—	—	—	—	1.5	1	45.0	34.5	50.0	18	10.8	31.3	12 500	17 900
95BNR10H	95	145	24	—	5.5	14.5	2.2	1.5	1	45.0	33.0	32.5	18	10.8	31.3	15 000	23 400
95BNR10X	95	145	24	29	5.5	14.5	2.2	1.5	1	71.5	33.0	32.5	18	10.8	31.3	17 500	27 500
95BER10E	95	145	24	—	—	—	—	1.5	1	43.0	33.0	58.5	25	—	39.7	10 800	15 200
95BER10H	95	145	24	—	5.5	14.5	2.2	1.5	1	43.0	31.5	39.5	25	—	39.7	13 400	20 900
95BER10X	95	145	24	29	5.5	14.5	2.2	1.5	1	68.0	31.5	39.5	25	—	39.7	15 900	25 000
7219C	95	170	32	—	—	—	—	2.1	1.1	167	112	76.0	15	14.6	33.7	8 700	13 300
7219CSN24	95	170	32	—	—	—	—	2.1	1.1	168	107	90.0	15	14.6	33.7	11 400	17 300
7219A5	95	170	32	—	—	—	—	2.1	1.1	159	107	87.0	25	—	46.9	7 600	11 400
7219A5SN24	95	170	32	—	—	—	—	2.1	1.1	160	103	103	25	—	46.9	9 900	14 800
7219A	95	170	32	—	—	—	—	2.1	1.1	154	103	67.0	30	—	54.2	5 700	7 600

Abutment and Fillet Dimensions (mm)					Preload (DB and DF Arrangement) (N)				Axial Rigidity (DB and DF Arrangement) (N/μm)				Measured Axial Clearance (μm)				Mass (kg) (approx.)
d_a (min.)	D_a (max.)	D_b (max.)	r_a (max.)	r_b (max.)	EL	L	M	H	EL	L	M	H	EL	L	M	H	
102	123	125	1	0.6	154	294	800	1 588	81	105	164	230	-3	-9	-24	-40	0.597
102	123	125	1	0.6	161	320	903	1 819	91	121	191	268	-3	-9	-24	-40	0.522
102	123	125	1	0.6	226	512	1 218	2 371	195	261	363	475	-3	-8	-17	-28	0.603
102	123	125	1	0.6	244	574	1 397	2 751	223	304	425	558	-3	-8	-17	-28	0.528
102	123	125	1	0.6	98	288	775	—	77	112	164	—	0	-8	-22	—	0.571
102	123	125	1	0.6	98	314	878	—	86	129	191	—	0	-8	-22	—	0.497
102	123	125	1	0.6	98	314	878	—	86	129	191	—	0	-8	-22	—	0.497
102	123	125	1	0.6	98	442	1 005	—	127	212	286	—	0	-8	-17	—	0.571
102	123	125	1	0.6	98	493	1 150	—	143	247	334	—	0	-8	-17	—	0.497
102	123	125	1	0.6	98	493	1 150	—	143	247	334	—	0	-8	-17	—	0.497
104	136	139	1.5	0.8	275	549	1 188	2 348	94	125	176	246	-9	-19	-36	-58	1.21
104	136	139	1.5	0.8	299	614	1 357	2 712	107	144	205	288	-9	-19	-36	-58	1.04
104	136	139	1.5	0.8	421	808	1 832	3 786	227	287	392	525	-7	-13	-25	-42	1.21
104	136	139	1.5	0.8	469	919	2 119	4 417	263	336	460	619	-7	-13	-25	-42	1.04
104	136	139	1.5	0.8	98	811	2 592	4 157	182	372	569	682	0	-10	-25	-35	1.23
104	136	139	1.5	0.8	98	345	854	—	77	120	170	—	0	-10	-24	—	1.30
104	136	139	1.5	0.8	98	380	971	—	86	138	198	—	0	-10	-24	—	1.21
104	136	139	1.5	0.8	98	380	971	—	86	138	198	—	0	-10	-24	—	1.21
104	136	139	1.5	0.8	98	671	1 381	—	127	246	320	—	0	-12	-22	—	1.30
104	136	139	1.5	0.8	98	760	1 590	—	143	287	375	—	0	-12	-22	—	1.21
104	136	139	1.5	0.8	98	760	1 590	—	143	287	375	—	0	-12	-22	—	1.21
107	158	163	2	1	448	876	2 081	4 153	98	130	192	270	-18	-33	-63	-99	2.64
107	158	163	2	1	498	995	2 404	4 834	114	151	225	317	-18	-33	-63	-99	2.18
107	158	163	2	1	703	1 390	3 124	6 301	240	308	419	557	-13	-23	-42	-68	2.63
107	158	163	2	1	796	1 601	3 639	7 386	280	361	494	657	-13	-23	-42	-68	2.17
107	158	163	2	1	356	1 633	4 191	6 644	248	422	596	711	-5	-20	-40	-55	2.67

(*) Bearings denoted by an asterisk (*) are available with seals. Series 20 and 29 are comprised exclusively of sealed bearings.
 (°) Spinslot II bearings are available for designations with values in the C column, and ROBUSTSHOT bearings are available for designations with values in the B_N , S_N , and S_B columns.
 (°) For details on permissible axial load, refer to Page 199.
 (°) For details on limiting speeds, refer to Page 216. See Page 51 for cage differences and their impact on d_{in} values.

Calculation of radial rigidity
 Multiply axial rigidity by the appropriate factor in Table A.
Calculation of preload and axial rigidity for combined bearings
 Multiply by the appropriate factor in Table B. For radial rigidity, multiply the value from Table A with the appropriate factor in Table B.

Table A	EL	L	M	H
15°	6.5	6.0	5.0	4.5
18°		4.5		
25°		2.0		
30°		1.4		

Table B	DBD	DBB
Preload factor	1.36	2
Axial rigidity	1.48	2
Radial rigidity	1.54	2

For additional information:
 ● Dynamic Equivalent Load ······ P191
 ● Static Equivalent Load ········ P198
 ● Spacer Dimensions and Nozzle Position ··· P237
 ● Recommended Grease Quantities ··· P257

1. Angular Contact Ball Bearings

Bore Diameter **100mm**

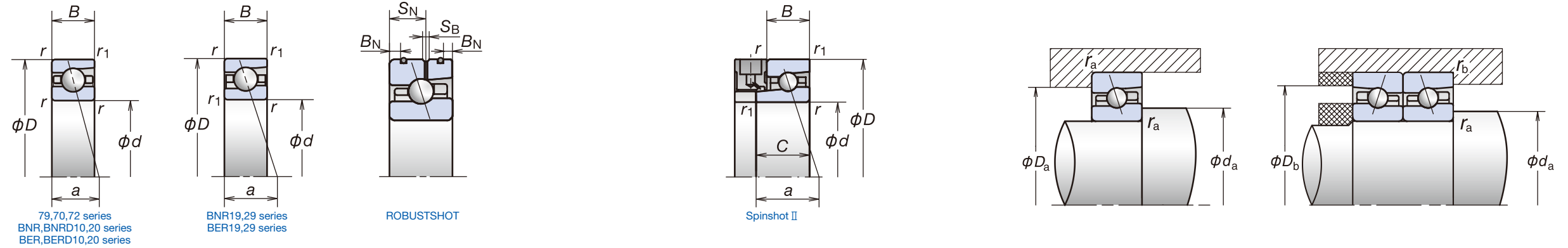

Designation (*)	Boundary Dimensions (*) (mm)								Basic Load Ratings (kN)		Permissible Axial Load (*) (kN)	Contact Angle (°)	Factor f_0	Effective Load Center (mm) a	Limiting Speeds (*) (min ⁻¹)		
	d	D	B	C	B_N	S_N	S_B	r (min.)	r_1 (min.)	C_r (Dynamic)					C_{or} (Static)	Grease	Oil
*7920C	100	140	20	—	—	—	—	1.1	0.6	63.0	54.0	33.0	15	16.5	26.1	9 600	14 600
*7920CSN24	100	140	20	—	—	—	—	1.1	0.6	63.5	52.0	39.2	15	16.5	26.1	12 500	19 000
*7920A5	100	140	20	—	—	—	—	1.1	0.6	59.5	51.5	39.5	25	—	38.0	8 400	12 500
*7920A5SN24	100	140	20	—	—	—	—	1.1	0.6	60.0	49.5	46.8	25	—	38.0	10 900	16 300
*100BNR19E	100	140	20	—	—	—	—	1.1	0.6	47.5	35.0	50.5	18	10.8	29.5	12 500	17 900
*100BNR19H	100	140	20	—	4.0	12.0	2.2	1.1	0.6	47.5	33.5	33.0	18	10.8	29.5	15 000	23 400
*100BNR19X	100	140	20	25	4.0	12.0	2.2	1.1	0.6	75.5	33.5	33.0	18	10.8	29.5	17 500	27 500
*100BER19E	100	140	20	—	—	—	—	1.1	0.6	45.5	33.5	59.5	25	—	38.0	10 800	15 200
*100BER19H	100	140	20	—	4.0	12.0	2.2	1.1	0.6	45.5	32.0	40.0	25	—	38.0	13 400	20 900
*100BER19X	100	140	20	25	4.0	12.0	2.2	1.1	0.6	72.5	32.0	40.0	25	—	38.0	15 900	25 000
*100BNR29EV1V	100	140	24	—	—	—	—	1.1	0.6	47.5	35.0	50.5	18	10.8	31.5	12 500	—
*100BNR29HV1V	100	140	24	—	—	—	—	1.1	0.6	47.5	33.5	33.0	18	10.8	31.5	15 000	—
*100BNR29XV1V	100	140	24	—	—	—	—	1.1	0.6	75.5	33.5	33.0	18	10.8	31.5	17 500	—
*100BER29EV1V	100	140	24	—	—	—	—	1.1	0.6	45.5	33.5	59.5	25	—	40.0	10 800	—
*100BER29HV1V	100	140	24	—	—	—	—	1.1	0.6	45.5	32.0	40.0	25	—	40.0	13 400	—
*100BER29XV1V	100	140	24	—	—	—	—	1.1	0.6	72.5	32.0	40.0	25	—	40.0	15 900	—
*7020C	100	150	24	—	—	—	—	1.5	1	95.0	77.0	49.0	15	16.0	28.7	9 200	14 000
*7020CSN24	100	150	24	—	—	—	—	1.5	1	95.0	74.0	58.4	15	16.0	28.7	12 000	18 300
*7020A5	100	150	24	—	—	—	—	1.5	1	89.5	73.5	57.5	25	—	41.1	8 000	12 000
*7020A5SN24	100	150	24	—	—	—	—	1.5	1	90.0	70.5	68.3	25	—	41.1	10 400	15 600
*7020A	100	150	24	—	—	—	—	1.5	1	86.0	70.5	44.5	30	—	48.1	6 000	8 000
*100BNR10E	100	150	24	—	—	—	—	1.5	1	45.5	36.0	52.0	18	10.9	32.3	12 000	17 200
*100BNR10H	100	150	24	—	5.5	14.5	2.2	1.5	1	45.5	34.5	34.0	18	10.9	32.3	14 400	22 400
*100BNR10X	100	150	24	29	5.5	14.5	2.2	1.5	1	72.0	34.5	34.0	18	10.9	32.3	16 800	26 400
*100BER10E	100	150	24	—	—	—	—	1.5	1	43.5	34.5	61.0	25	—	41.2	10 400	14 600
*100BER10H	100	150	24	—	5.5	14.5	2.2	1.5	1	43.5	33.0	41.0	25	—	41.2	12 800	20 000
*100BER10X	100	150	24	29	5.5	14.5	2.2	1.5	1	69.0	33.0	41.0	25	—	41.2	15 200	24 000
*100BNRD10J	100	150	24	—	5.5	14.5	2.2	1.5	1	84.0	39.0	38.0	18	8.2	32.3	14 400	22 400
*100BNRD10X	100	150	24	29	5.5	14.5	2.2	1.5	1	106	39.0	38.0	18	8.2	32.3	16 800	26 400
*100BERD10J	100	150	24	—	5.5	14.5	2.2	1.5	1	80.5	37.5	46.5	25	—	41.1	12 800	20 000
*100BERD10X	100	150	24	29	5.5	14.5	2.2	1.5	1	102	37.5	46.5	25	—	41.1	15 200	24 000
*100BNR20EV1V	100	150	30	—	—	—	—	1.5	1	45.5	36.0	52.0	18	10.9	35.3	12 000	—
*100BNR20HV1V	100	150	30	—	—	—	—	1.5	1	45.5	34.5	34.0	18	10.9	35.3	14 400	—
*100BNR20XV1V	100	150	30	—	—	—	—	1.5	1	72.0	34.5	34.0	18	10.9	35.3	16 800	—
*100BER20EV1V	100	150	30	—	—	—	—	1.5	1	43.5	34.5	61.0	25	—	44.2	10 400	—
*100BER20HV1V	100	150	30	—	—	—	—	1.5	1	43.5	33.0	41.0	25	—	44.2	12 800	—
*100BER20XV1V	100	150	30	—	—	—	—	1.5	1	69.0	33.0	41.0	25	—	44.2	15 200	—
7220C	100	180	34	—	—	—	—	2.1	1.1	188	127	88.5	15	14.5	35.7	8 300	12 500
7220A5	100	180	34	—	—	—	—	2.1	1.1	179	121	103	25	—	49.6	7 200	10 800
7220A	100	180	34	—	—	—	—	2.1	1.1	173	117	79.5	30	—	57.4	5 400	7 200

Abutment and Fillet Dimensions (mm)					Preload (DB and DF Arrangement) (N)				Axial Rigidity (DB and DF Arrangement) (N/μm)				Measured Axial Clearance (μm)				Mass (kg) (approx.)
d_a (min.)	D_a (max.)	D_b (max.)	r_a (max.)	r_b (max.)	EL	L	M	H	EL	L	M	H	EL	L	M	H	
107	133	135	1	0.6	191	387	905	1 790	84	112	164	230	— 5	— 13	— 28	— 46	0.800
107	133	135	1	0.6	203	427	1 026	2 057	95	129	191	268	— 5	— 13	— 28	— 46	0.702
107	133	135	1	0.6	318	615	1 229	2 546	209	266	346	463	— 5	— 10	— 18	— 31	0.808
107	133	135	1	0.6	348	694	1 410	2 956	241	310	405	545	— 5	— 10	— 18	— 31	0.710
107	133	135	1	0.6	98	329	879	—	72	111	162	—	0	— 10	— 26	—	0.770
107	133	135	1	0.6	98	362	1 000	—	81	128	189	—	0	— 10	— 26	—	0.673
107	133	135	1	0.6	98	362	1 000	—	81	128	189	—	0	— 10	— 26	—	0.673
107	133	135	1	0.6	98	522	1 142	—	120	213	282	—	0	— 10	— 20	—	0.770
107	133	135	1	0.6	98	585	1 311	—	135	247	330	—	0	— 10	— 20	—	0.673
107	133	135	1	0.6	98	585	1 311	—	135	247	330	—	0	— 10	— 20	—	0.673
107	133	135	1	0.6	98	329	879	—	72	111	162	—	0	— 10	— 26	—	0.902
107	133	135	1	0.6	98	362	1 000	—	81	128	189	—	0	— 10	— 26	—	0.805
107	133	135	1	0.6	98	362	1 000	—	81	128	189	—	0	— 10	— 26	—	0.805
107	133	135	1	0.6	98	522	1 142	—	120	213	282	—	0	— 10	— 20	—	0.902
107	133	135	1	0.6	98	585	1 311	—	135	247	330	—	0	— 10	— 20	—	0.805
107	133	135	1	0.6	98	585	1 311	—	135	247	330	—	0	— 10	— 20	—	0.805
109	141	144	1.5	0.8	282	534	1 278	2 572	97	126	187	264	— 9	— 18	— 37	— 60	1.27
109	141	144	1.5	0.8	306	596	1 462	2 974	111	146	218	309	— 9	— 18	— 37	— 60	1.09
109	141	144	1.5	0.8	434	837	2 009	3 948	236	300	418	549	— 7	— 13	— 26	— 42	1.45
109	141	144	1.5	0.8	483	953	2 327	4 609	274	350	491	647	— 7	— 13	— 26	— 42	1.27
109	141	144	1.5	0.8	98	840	2 701	4 338	188	388	595	713	0	— 10	— 25	— 35	1.28
109	141	144	1.5	0.8	98	352	877	—	78	123	175	—	0	— 10	— 24	—	1.34
109	141	144	1.5	0.8	98	389	999	—	88	142	205	—	0	— 10	— 24	—	1.25
109	141	144	1.5	0.8	98	389	999	—	88	142	205	—	0	— 10	— 24	—	1.25
109	141	144	1.5	0.8	98	689	1 423	—	130	254	331	—	0	— 12	— 22	—	1.34
109	141	144	1.5	0.8	98	780	1 639	—	146	296	388	—	0	— 12	— 22	—	1.25
109	141	144	1.5	0.8	98	780	1 639	—	146	296	388	—	0	— 12	— 22	—	1.25
109	141	144	1.5	0.8	98	706	1 488	—	82	167	223	—	0	— 19	— 35	—	1.10
109	141	144	1.5	0.8	98	706	1 488	—	82	167	223	—	0	— 19	— 35	—	1.10
109	141	144	1.5	0.8	98	950	1 993	—	137	300	392	—	0	— 15	— 27	—	1.10
109	141	144	1.5	0.8	98	950	1 993	—	137	300	392	—	0	— 15	— 27	—	1.10
109	141	144	1.5	0.8	98	352	877	—	78	123	175	—	0	— 10	— 24	—	1.65
109	141	144	1.5	0.8	98	389	999	—	88	142	205	—	0	— 10	— 24	—	1.56
109	141	144	1.5	0.8	98	389	999	—	88	142	205	—	0	— 10	— 24	—	1.56
109	141	144	1.5	0.8	98	689	1 423	—	130	254	331	—	0	— 12	— 22	—	1.65
109	141	144	1.5	0.8	98	780	1 639	—	146	296	388	—	0	— 12	— 22	—	1.56
109	141	144	1.5	0.8	98	780	1 639	—	146	296							

1. Angular Contact Ball Bearings

Bore Diameter **105mm**

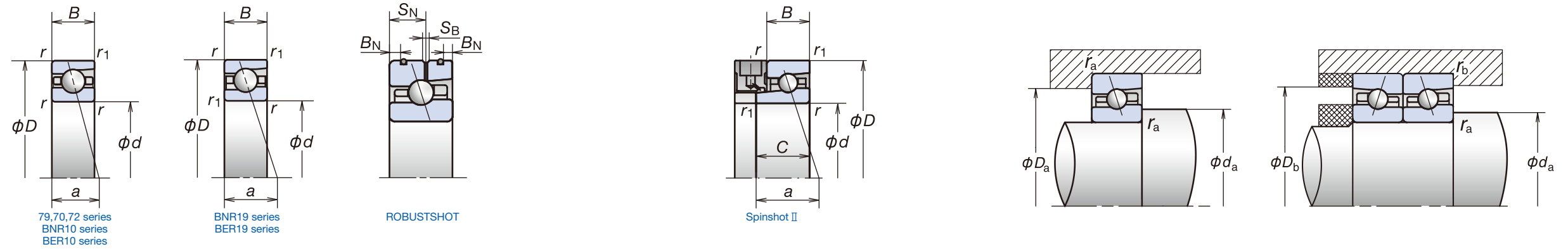

Designation (*)	Boundary Dimensions (°) (mm)								Basic Load Ratings (kN)		Permissible Axial Load (°) (kN)	Contact Angle (°)	Factor f_0	Effective Load Center (mm) a	Limiting Speeds (°) (min ⁻¹)		
	d	D	B	C	B_N	S_N	S_B	r (min.)	r_1 (min.)	C_r (Dynamic)					C_{or} (Static)	Grease	Oil
7921C	105	145	20	—	—	—	—	1.1	0.6	64.5	57.0	34.5	15	16.6	26.7	9 200	14 000
7921CSN24	105	145	20	—	—	—	—	1.1	0.6	64.5	54.5	40.8	15	16.6	26.7	12 000	18 300
7921A5	105	145	20	—	—	—	—	1.1	0.6	60.5	54.0	41.0	25	—	39.2	8 000	12 000
7921A5SN24	105	145	20	—	—	—	—	1.1	0.6	61.0	51.5	48.7	25	—	39.2	10 400	15 600
105BNR19E	105	145	20	—	—	—	—	1.1	0.6	48.5	36.5	53.0	18	10.8	30.3	12 000	17 200
105BNR19H	105	145	20	—	—	—	—	1.1	0.6	48.5	35.0	39.0	18	10.8	30.3	14 400	22 400
105BNR19X	105	145	20	25	—	—	—	1.1	0.6	77.0	35.0	39.0	18	10.8	30.3	16 800	26 400
105BER19E	105	145	20	—	—	—	—	1.1	0.6	46.5	35.0	62.0	25	—	39.2	10 400	14 600
105BER19H	105	145	20	—	—	—	—	1.1	0.6	46.5	33.5	42.0	25	—	39.2	12 800	20 000
105BER19X	105	145	20	25	—	—	—	1.1	0.6	73.5	33.5	42.0	25	—	39.2	15 200	24 000
7021C	105	160	26	—	—	—	—	2	1	111	89.5	57.0	15	15.9	30.7	8 700	13 300
7021CSN24	105	160	26	—	—	—	—	2	1	111	85.5	68.1	15	15.9	30.7	11 400	17 300
7021A5	105	160	26	—	—	—	—	2	1	105	85.0	66.5	25	—	43.9	7 600	11 400
7021A5SN24	105	160	26	—	—	—	—	2	1	105	81.0	79.0	25	—	43.9	9 900	14 800
7021A	105	160	26	—	—	—	—	2	1	101	81.5	51.0	30	—	51.2	5 700	7 600
105BNR10E	105	160	26	—	—	—	—	2	1	51.5	41.0	59.5	18	10.9	34.5	11 400	16 200
105BNR10H	105	160	26	—	6.0	15.2	2.2	2	1	51.5	39.5	39.0	18	10.9	34.5	13 600	21 200
105BNR10X	105	160	26	31	6.0	15.2	2.2	2	1	82.0	39.5	39.0	18	10.9	34.5	15 900	25 000
105BER10E	105	160	26	—	—	—	—	2	1	49.5	39.5	70.0	25	—	43.9	9 800	13 800
105BER10H	105	160	26	—	6.0	15.2	2.2	2	1	49.5	38.0	47.5	25	—	43.9	12 100	18 900
105BER10X	105	160	26	31	6.0	15.2	2.2	2	1	78.5	38.0	47.5	25	—	43.9	14 400	22 700
7221C	105	190	36	—	—	—	—	2.1	1.1	205	143	97.5	15	14.5	37.7	7 800	11 900
7221A5	105	190	36	—	—	—	—	2.1	1.1	195	137	111	25	—	52.4	6 800	10 200
7221A	105	190	36	—	—	—	—	2.1	1.1	188	132	85.0	30	—	60.6	5 100	6 800

Abutment and Fillet Dimensions (mm)					Preload (DB and DF Arrangement) (N)				Axial Rigidity (DB and DF Arrangement) (N/μm)				Measured Axial Clearance (μm)				Mass (kg) (approx.)
d_a (min.)	D_a (max.)	D_b (max.)	r_a (max.)	r_b (max.)	EL	L	M	H	EL	L	M	H	EL	L	M	H	
112	138	140	1	0.6	194	396	890	1 791	86	116	167	235	-5	-13	-27	-45	0.831
112	138	140	1	0.6	206	437	1 009	2 058	98	133	193	274	-5	-13	-27	-45	0.729
112	138	140	1	0.6	272	565	1 361	2 760	203	265	369	491	-4	-9	-19	-32	0.820
112	138	140	1	0.6	296	636	1 565	3 208	234	308	432	577	-4	-9	-19	-32	0.718
112	138	140	1	0.6	98	336	906	—	74	115	168	—	0	-10	-26	—	0.795
112	138	140	1	0.6	98	370	1 032	—	83	133	196	—	0	-10	-26	—	0.693
112	138	140	1	0.6	98	370	1 032	—	83	133	196	—	0	-10	-26	—	0.693
112	138	140	1	0.6	98	536	1 180	—	124	220	293	—	0	-10	-20	—	0.795
112	138	140	1	0.6	98	602	1 355	—	139	256	343	—	0	-10	-20	—	0.693
112	138	140	1	0.6	98	602	1 355	—	139	256	343	—	0	-10	-20	—	0.693
115	150	154	2	1	330	625	1 494	2 973	103	134	197	276	-11	-21	-42	-67	1.58
115	150	154	2	1	362	703	1 715	3 446	118	155	230	324	-11	-21	-42	-67	1.34
115	150	154	2	1	493	989	2 211	4 473	247	318	431	572	-8	-15	-28	-46	1.82
115	150	154	2	1	553	1 131	2 564	5 228	287	372	507	674	-8	-15	-28	-46	1.58
115	150	154	2	1	98	840	2 693	4 318	188	388	591	707	0	-10	-25	-35	1.60
115	150	154	2	1	98	424	1 034	—	80	135	190	—	0	-12	-27	—	1.70
115	150	154	2	1	98	471	1 182	—	89	156	222	—	0	-12	-27	—	1.59
115	150	154	2	1	98	471	1 182	—	89	156	222	—	0	-12	-27	—	1.59
115	150	154	2	1	98	911	1 815	—	133	286	369	—	0	-15	-26	—	1.70
115	150	154	2	1	98	1 039	2 100	—	149	335	434	—	0	-15	-26	—	1.59
115	150	154	2	1	98	1 039	2 100	—	149	335	434	—	0	-15	-26	—	1.59
117	178	183	2	1	540	1 077	2 651	5 311	108	144	216	304	-21	-38	-73	-114	3.78
117	178	183	2	1	862	1 790	3 950	7 929	268	348	471	625	-15	-27	-48	-77	3.77
117	178	183	2	1	368	2 298	5 208	8 924	260	493	666	818	-5	-25	-45	-65	3.82

(*) Bearings denoted by an asterisk (*) are available with seals. Series 20 and 29 are comprised exclusively of sealed bearings.
 (°) Spinshot II bearings are available for designations with values in the C column, and ROBUSTSHOT bearings are available for designations with values in the B_N , S_N , and S_B columns.
 (°) For details on permissible axial load, refer to Page 199.
 (°) For details on limiting speeds, refer to Page 216. See Page 51 for cage differences and their impact on d_{mr} values.

Calculation of radial rigidity
 Multiply axial rigidity by the appropriate factor in Table A.

Table A	EL	L	M	H
15°	6.5	6.0	5.0	4.5
18°	4.5			
25°	2.0			
30°	1.4			

Calculation of preload and axial rigidity for combined bearings
 Multiply by the appropriate factor in Table B. For radial rigidity, multiply the value from Table A with the appropriate factor in Table B.

Table B	DBD	DBB
Preload factor	1.36	2
Axial rigidity	1.48	2
Radial rigidity	1.54	2

For additional information:

- Dynamic Equivalent Load ······ P191
- Static Equivalent Load ······ P198
- Spacer Dimensions and Nozzle Position ··· P237
- Recommended Grease Quantities ··· P257

1. Angular Contact Ball Bearings

Bore Diameter **110mm**

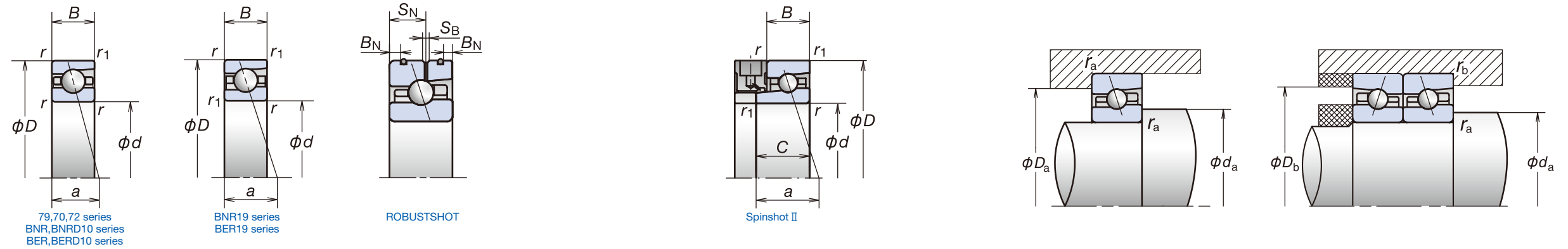

Designation (*)	Boundary Dimensions (°) (mm)								Basic Load Ratings (kN)		Permissible Axial Load (°) (kN)	Contact Angle (°)	Factor f_0	Effective Load Center (mm) a	Limiting Speeds (°) (min ⁻¹)		
	d	D	B	C	B_N	S_N	S_B	r (min.)	r_1 (min.)	C_r (Dynamic)					C_{or} (Static)	Grease	Oil
7922C	110	150	20	—	—	—	—	1.1	0.6	65.5	59.5	35.5	15	16.7	27.4	8 900	13 500
7922CSN24	110	150	20	—	—	—	—	1.1	0.6	65.5	57.0	42.4	15	16.7	27.4	11 600	17 600
7922A5	110	150	20	—	—	—	—	1.1	0.6	62.0	56.0	43.0	25	—	40.3	7 700	11 600
7922A5SN24	110	150	20	—	—	—	—	1.1	0.6	62.0	54.0	50.7	25	—	40.3	10 000	15 000
* 110BNR19E	110	150	20	—	—	—	—	1.1	0.6	49.5	38.0	55.5	18	10.9	31.1	11 600	16 500
* 110BNR19H	110	150	20	—	4.0	12.0	2.2	1.1	0.6	49.5	36.5	36.5	18	10.9	31.1	13 900	21 600
* 110BNR19X	110	150	20	25	4.0	12.0	2.2	1.1	0.6	78.5	36.5	36.5	18	10.9	31.1	16 200	25 400
* 110BER19E	110	150	20	—	—	—	—	1.1	0.6	47.0	36.5	65.0	25	—	40.3	10 000	14 000
* 110BER19H	110	150	20	—	4.0	12.0	2.2	1.1	0.6	47.0	35.0	44.0	25	—	40.3	12 400	19 300
* 110BER19X	110	150	20	25	4.0	12.0	2.2	1.1	0.6	75.0	35.0	44.0	25	—	40.3	14 700	23 100
7022C	110	170	28	—	—	—	—	2	1	134	104	68.5	15	15.6	32.7	8 300	12 500
7022CSN24	110	170	28	—	—	—	—	2	1	133	99.0	81.0	15	15.6	32.7	10 800	16 300
7022A5	110	170	28	—	—	—	—	2	1	127	99.0	79.5	25	—	46.6	7 200	10 800
7022A5SN24	110	170	28	—	—	—	—	2	1	126	94.0	94.1	25	—	46.6	9 300	14 000
7022A	110	170	28	—	—	—	—	2	1	122	95.5	61.0	30	—	54.4	5 400	7 200
110BNR10E	110	170	28	—	—	—	—	2	1	58.0	47.0	68.0	18	10.9	36.7	10 800	15 300
110BNR10H	110	170	28	—	6.0	16.2	2.2	2	1	58.0	45.0	44.5	18	10.9	36.7	12 900	20 000
110BNR10X	110	170	28	33	6.0	16.2	2.2	2	1	92.0	45.0	44.5	18	10.9	36.7	15 000	23 600
110BER10E	110	170	28	—	—	—	—	2	1	55.5	45.0	79.5	25	—	46.7	9 300	13 000
110BER10H	110	170	28	—	6.0	16.2	2.2	2	1	55.5	43.0	54.0	25	—	46.7	11 500	17 900
110BER10X	110	170	28	33	6.0	16.2	2.2	2	1	88.0	43.0	54.0	25	—	46.7	13 600	21 500
110BNRD10J	110	170	28	—	—	—	—	2	1	118	53.0	51.0	18	8.1	36.7	12 900	20 000
110BNRD10X	110	170	28	—	6.0	16.2	2.2	2	1	148	53.0	51.0	18	8.1	36.7	15 000	23 600
110BERD10J	110	170	28	—	—	—	—	2	1	113	51.0	63.0	25	—	46.6	11 500	17 900
110BERD10X	110	170	28	—	6.0	16.2	2.2	2	1	142	51.0	63.0	25	—	46.6	13 600	21 500
7222C	110	200	38	—	—	—	—	2.1	1.1	222	160	108	15	14.5	39.8	7 500	11 300
7222A5	110	200	38	—	—	—	—	2.1	1.1	211	153	126	25	—	55.1	6 500	9 700
7222A	110	200	38	—	—	—	—	2.1	1.1	204	148	97.0	30	—	63.7	4 900	6 500

Abutment and Fillet Dimensions (mm)					Preload (DB and DF Arrangement) (N)				Axial Rigidity (DB and DF Arrangement) (N/μm)				Measured Axial Clearance (μm)				Mass (kg) (approx.)
d_a (min.)	D_a (max.)	D_b (max.)	r_a (max.)	r_b (max.)	EL	L	M	H	EL	L	M	H	EL	L	M	H	
117	143	145	1	0.6	196	405	916	1 849	89	120	173	243	-5	-13	-27	-45	0.867
117	143	145	1	0.6	209	447	1 039	2 126	101	138	200	284	-5	-13	-27	-45	0.761
117	143	145	1	0.6	332	651	1 502	2 985	224	286	393	519	-5	-10	-20	-33	0.877
117	143	145	1	0.6	365	735	1 731	3 474	258	333	461	610	-5	-10	-20	-33	0.771
117	143	145	1	0.6	98	405	933	—	76	126	174	—	0	-12	-26	—	0.838
117	143	145	1	0.6	98	450	1 064	—	85	146	204	—	0	-12	-26	—	0.733
117	143	145	1	0.6	98	450	1 064	—	85	146	204	—	0	-12	-26	—	0.733
117	143	145	1	0.6	98	550	1 218	—	127	228	304	—	0	-10	-20	—	0.838
117	143	145	1	0.6	98	619	1 400	—	142	266	356	—	0	-10	-20	—	0.733
117	143	145	1	0.6	98	619	1 400	—	142	266	356	—	0	-10	-20	—	0.733
120	160	164	2	1	371	733	1 752	3 516	104	137	203	285	-13	-25	-49	-78	1.97
120	160	164	2	1	409	829	2 018	4 085	120	160	237	334	-13	-25	-49	-78	1.65
120	160	164	2	1	604	1 194	2 657	5 250	258	330	447	588	-10	-18	-33	-53	1.97
120	160	164	2	1	682	1 371	3 090	6 146	300	387	527	694	-10	-18	-33	-53	1.65
120	160	164	2	1	98	1 325	3 331	5 949	183	443	620	774	0	-15	-30	-45	1.97
120	160	164	2	1	98	539	1 154	—	82	150	201	—	0	-15	-29	—	2.13
120	160	164	2	1	98	605	1 323	—	91	174	235	—	0	-15	-29	—	2.00
120	160	164	2	1	98	605	1 323	—	91	174	235	—	0	-15	-29	—	2.00
120	160	164	2	1	98	932	1 860	—	136	294	379	—	0	-15	-26	—	2.13
120	160	164	2	1	98	1 065	2 153	—	153	344	445	—	0	-15	-26	—	2.00
120	160	164	2	1	98	1 065	2 153	—	153	344	445	—	0	-15	-26	—	2.00
120	160	164	2	1	98	986	1 996	—	81	183	241	—	0	-26	-45	—	1.65
120	160	164	2	1	98	986	1 996	—	81	183	241	—	0	-26	-45	—	1.65
120	160	164	2	1	98	1 312	2 735	—	134	328	428	—	0	-20	-35	—	1.65
120	160	164	2	1	98	1 312	2 735	—	134	328	428	—	0	-20	-35	—	1.65
122	188	193	2	1	632	1 281	2 962	5 901	117	156	228	320	-24	-43	-78	-121	4.45
122	188	193	2	1	948	2 009	4 400	9 396	281	369	497	676	-16	-29	-51	-85	4.45
122	188	193	2	1	374	2 350	6 201	10 187	266	505	721	872	-5	-25	-50	-70	4.49

(*) Bearings denoted by an asterisk (*) are available with seals. Series 20 and 29 are comprised exclusively of sealed bearings.
 (°) Spinshot II bearings are available for designations with values in the C column, and ROBUSTSHOT bearings are available for designations with values in the B_N , S_N , and S_B columns.
 (°) For details on permissible axial load, refer to Page 199.
 (°) For details on limiting speeds, refer to Page 216. See Page 51 for cage differences and their impact on d_{in}/r values.

Calculation of radial rigidity
 Multiply axial rigidity by the appropriate factor in Table A.

Table A	EL	L	M	H
15°	6.5	6.0	5.0	4.5
18°	4.5			
25°	2.0			
30°	1.4			

Calculation of preload and axial rigidity for combined bearings
 Multiply by the appropriate factor in Table B. For radial rigidity, multiply the value from Table A with the appropriate factor in Table B.

Table B	DBD	DBB
Preload factor	1.36	2
Axial rigidity	1.48	2
Radial rigidity	1.54	2

For additional information:
 ● Dynamic Equivalent Load ······P191
 ● Static Equivalent Load ······P198
 ● Spacer Dimensions and Nozzle Position ···P237
 ● Recommended Grease Quantities ···P257

1. Angular Contact Ball Bearings

Bore Diameter **120mm**

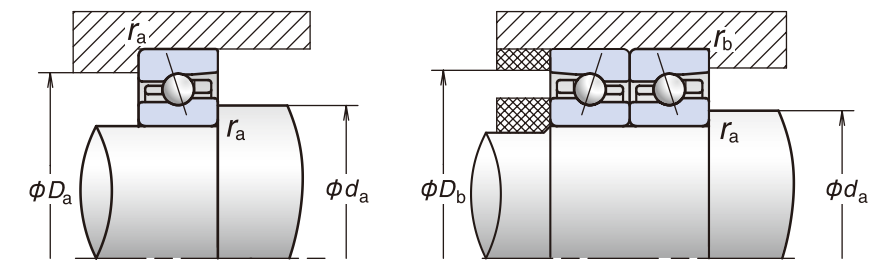
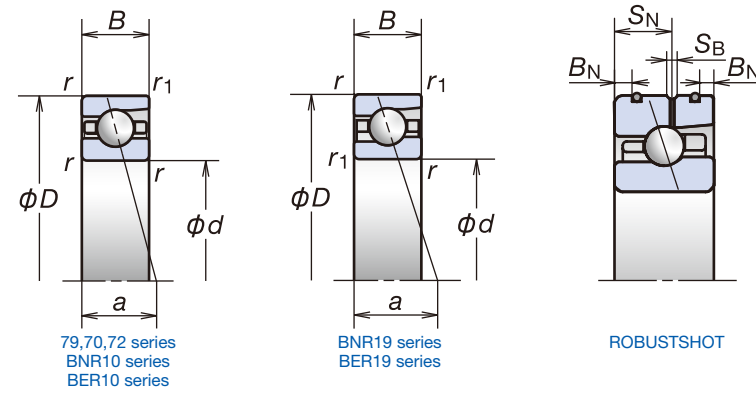

Designation (*)	Boundary Dimensions (°) (mm)								Basic Load Ratings (kN)		Permissible Axial Load (°) (kN)	Contact Angle (°)	Factor fo	Effective Load Center (mm) a	Limiting Speeds (°) (min ⁻¹)	
	d	D	B	BN	SN	SB	r (min.)	r1 (min.)	Cr (Dynamic)	Cor (Static)					Grease	Oil
7924C	120	165	22	—	—	—	1.1	0.6	90.5	81.0	50.5	15	16.5	30.1	8 100	12 300
7924CSN24	120	165	22	—	—	—	1.1	0.6	90.5	77.5	59.8	15	16.5	30.1	10 600	16 000
7924A5	120	165	22	—	—	—	1.1	0.6	85.5	77.0	59.5	25	—	44.2	7 100	10 600
7924A5SN24	120	165	22	—	—	—	1.1	0.6	85.5	73.5	70.8	25	—	44.2	9 200	13 700
120BNR19S	120	165	22	—	—	—	1.1	0.6	68.0	52.0	75.0	18	10.8	34.2	9 900	14 100
120BNR19H	120	165	22	—	—	—	1.1	0.6	68.0	50.0	49.0	18	10.8	34.2	12 700	19 700
120BNR19X	120	165	22	—	—	—	1.1	0.6	108	50.0	49.0	18	10.8	34.2	14 800	23 200
120BER19S	120	165	22	—	—	—	1.1	0.6	65.0	50.0	88.0	25	—	44.2	8 500	12 000
120BER19H	120	165	22	—	—	—	1.1	0.6	65.0	48.0	59.5	25	—	44.2	11 300	17 600
120BER19X	120	165	22	—	—	—	1.1	0.6	103	48.0	59.5	25	—	44.2	13 400	21 100
7024C	120	180	28	—	—	—	2	1	141	117	75.5	15	15.8	34.1	7 700	11 700
7024CSN24	120	180	28	—	—	—	2	1	141	111	89.4	15	15.8	34.1	10 000	15 200
7024A5	120	180	28	—	—	—	2	1	134	111	87.5	25	—	49.0	6 700	10 000
7024A5SN24	120	180	28	—	—	—	2	1	133	105	104	25	—	49.0	8 700	13 000
7024A	120	180	28	—	—	—	2	1	128	107	67.5	30	—	57.3	5 000	6 700
*120BNR10E	120	180	28	—	—	—	2	1	60.0	50.5	73.5	18	11.0	38.4	9 400	13 400
*120BNR10H	120	180	28	6.0	16.2	2.2	2	1	60.0	48.5	48.0	18	11.0	38.4	12 000	18 700
*120BNR10X	120	180	28	6.0	16.2	2.2	2	1	95.0	48.5	48.0	18	11.0	38.4	14 000	22 000
*120BER10E	120	180	28	—	—	—	2	1	57.0	48.5	86.0	25	—	49.0	8 000	11 400
*120BER10H	120	180	28	6.0	16.2	2.2	2	1	57.0	46.5	58.0	25	—	49.0	10 700	16 700
*120BER10X	120	180	28	6.0	16.2	2.2	2	1	90.5	46.5	58.0	25	—	49.0	12 700	20 000
7224C	120	215	40	—	—	—	2.1	1.1	250	192	132	15	14.6	42.4	6 900	10 500
7224A5	120	215	40	—	—	—	2.1	1.1	238	184	150	25	—	59.1	6 000	9 000
7224A	120	215	40	—	—	—	2.1	1.1	230	177	116	30	—	68.3	4 500	6 000

(*) Bearings denoted by an asterisk (*) are available with seals.
 (°) ROBUSTSHOT bearings are available for designations with values in the BN, SN, and SB columns.
 (°) For details on permissible axial load, refer to Page 199.
 (°) For details on limiting speeds, refer to Page 216. See Page 51 for cage differences and their impact on d_nn values.

Abutment and Fillet Dimensions (mm)					Preload (DB and DF Arrangement) (N)				Axial Rigidity (DB and DF Arrangement) (N/μm)				Measured Axial Clearance (μm)				Mass (kg) (approx.)
d _a (min.)	D _a (max.)	D _b (max.)	r _a (max.)	r _b (max.)	EL	L	M	H	EL	L	M	H	EL	L	M	H	
127	158	160	1	0.6	270	536	1 288	2 539	102	135	199	278	-8	-17	-35	-56	1.16
127	158	160	1	0.6	293	600	1 474	2 935	116	156	232	325	-8	-17	-35	-56	0.983
127	158	160	1	0.6	461	902	1 964	3 884	257	328	441	580	-7	-13	-24	-39	1.15
127	158	160	1	0.6	515	1 029	2 275	4 533	299	384	518	684	-7	-13	-24	-39	0.973
127	158	160	1	0.6	98	414	1 287	—	78	130	200	—	0	-12	-33	—	1.12
127	158	160	1	0.6	98	460	1 477	—	88	150	234	—	0	-12	-33	—	0.949
127	158	160	1	0.6	98	460	1 477	—	88	150	234	—	0	-12	-33	—	0.949
127	158	160	1	0.6	98	689	1 761	—	131	253	355	—	0	-12	-26	—	1.12
127	158	160	1	0.6	98	781	2 037	—	147	296	417	—	0	-12	-26	—	0.949
127	158	160	1	0.6	98	781	2 037	—	147	296	417	—	0	-12	-26	—	0.949
130	170	174	2	1	422	825	1 959	3 918	116	153	225	316	-14	-26	-50	-79	2.09
130	170	174	2	1	468	936	2 260	4 557	134	178	264	371	-14	-26	-50	-79	1.74
130	170	174	2	1	648	1 295	2 903	5 921	282	363	492	656	-10	-18	-33	-54	2.43
130	170	174	2	1	733	1 489	3 380	6 939	329	425	580	774	-10	-18	-33	-54	2.08
130	170	174	2	1	98	1 439	3 645	6 531	196	487	683	853	0	-15	-30	-45	2.12
130	170	174	2	1	98	565	1 220	—	85	159	214	—	0	-15	-29	—	2.29
130	170	174	2	1	98	634	1 399	—	96	185	251	—	0	-15	-29	—	2.14
130	170	174	2	1	98	634	1 399	—	96	185	251	—	0	-15	-29	—	2.14
130	170	174	2	1	98	983	1 973	—	143	313	404	—	0	-15	-26	—	2.29
130	170	174	2	1	98	1 125	2 286	—	160	367	475	—	0	-15	-26	—	2.14
130	170	174	2	1	98	1 125	2 286	—	160	367	475	—	0	-15	-26	—	2.14
132	203	208	2	1	690	1 395	3 212	6371	127	170	246	343	-19	-38	-73	-116	5.42
132	203	208	2	1	1 137	2 327	5 259	1 0296	318	412	562	736	-15	-28	-52	-83	5.42
132	203	208	2	1	542	2 817	8 158	1 1550	321	570	844	964	-5	-25	-55	-70	5.45

Calculation of radial rigidity
 Multiply axial rigidity by the appropriate factor in Table A.

Table A	EL	L	M	H
15°	6.5	6.0	5.0	4.5
18°	4.5			
25°	2.0			
30°	1.4			

Calculation of preload and axial rigidity for combined bearings
 Multiply by the appropriate factor in Table B. For radial rigidity, multiply the value from Table A with the appropriate factor in Table B.

Table B	DBD	DBB
Preload factor	1.36	2
Axial rigidity	1.48	2
Radial rigidity	1.54	2

Table A

EL	L	M	H	
15°	6.5	6.0	5.0	4.5
18°	4.5			
25°	2.0			
30°	1.4			

Table B

DBD	DBB	
Preload factor	1.36	2
Axial rigidity	1.48	2
Radial rigidity	1.54	2

For additional information:

- Dynamic Equivalent Load ······P191
- Static Equivalent Load ······P198
- Spacer Dimensions and Nozzle Position ···P237
- Recommended Grease Quantities ···P257

1. Angular Contact Ball Bearings

Bore Diameter **130mm**

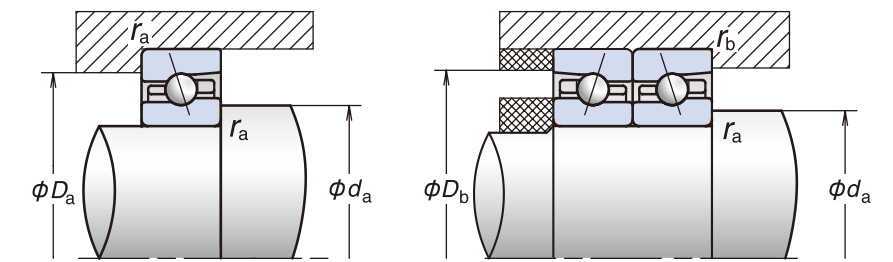
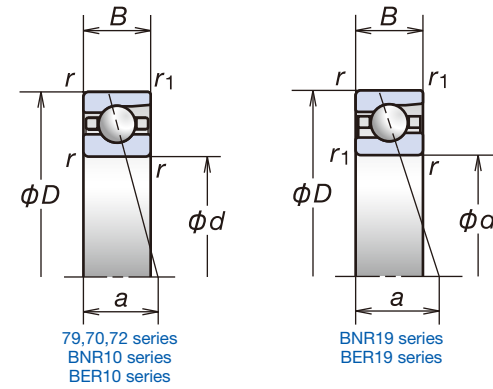

Designation	Boundary Dimensions (mm)					Basic Load Ratings (kN)		Permissible Axial Load (1) (kN)	Contact Angle (°)	Factor f ₀	Effective Load Center (mm) a	Limiting Speeds (2) (min ⁻¹)	
	d	D	B	r (min.)	r ₁ (min.)	C _r (Dynamic)	C _{0r} (Static)					Grease	Oil
7926C	130	180	24	1.5	1	99.0	91.0	55.0	15	16.5	32.8	7 500	11 300
7926CSN24	130	180	24	1.5	1	99.0	87.0	65.6	15	16.5	32.8	9 700	14 800
7926A5	130	180	24	1.5	1	93.5	86.0	63.5	25	—	48.1	6 500	9 700
7926A5SN24	130	180	24	1.5	1	93.5	82.5	75.6	25	—	48.1	8 400	12 600
130BNR19E	130	180	24	1.5	1	75.0	58.5	85.0	18	10.9	37.2	9 700	13 900
130BNR19H	130	180	24	1.5	1	75.0	56.0	56.0	18	10.9	37.2	11 700	18 100
130BER19E	130	180	24	1.5	1	71.5	56.5	100	25	—	48.1	8 400	11 800
130BER19H	130	180	24	1.5	1	71.5	54.0	67.5	25	—	48.1	10 400	16 200
7026C	130	200	33	2	1	163	137	86.0	15	15.9	38.6	7 000	10 700
7026CSN24	130	200	33	2	1	163	132	102	15	15.9	38.6	9 100	13 900
7026A5	130	200	33	2	1	154	130	99.5	25	—	55.0	6 100	9 100
7026A5SN24	130	200	33	2	1	154	125	118	25	—	55.0	7 900	11 900
7026A	130	200	33	2	1	148	125	76.5	30	—	64.1	4 600	6 100
130BNR10E	130	200	33	2	1	75.5	61.5	89.5	18	11.0	43.0	9 100	13 000
130BNR10H	130	200	33	2	1	75.5	59.0	58.5	18	11.0	43.0	11 000	17 000
130BER10E	130	200	33	2	1	72.5	59.0	105	25	—	55.0	7 900	11 100
130BER10H	130	200	33	2	1	72.5	56.5	70.5	25	—	55.0	9 700	15 200
7226C	130	230	40	3	1.1	260	209	144	15	14.9	44.1	6 400	9 800
7226A5	130	230	40	3	1.1	248	199	163	25	—	62.0	5 600	8 400
7226A	130	230	40	3	1.1	239	193	127	30	—	72.0	4 200	5 600

(1) For details on permissible axial load, refer to Page 199.

(2) For details on limiting speeds, refer to Page 216. See Page 51 for cage differences and their impact on $d_{m1}n$ values.

Abutment and Fillet Dimensions (mm)					Preload (DB and DF Arrangement) (N)				Axial Rigidity (DB and DF Arrangement) (N/μm)				Measured Axial Clearance (μm)				Mass (kg) (approx.)
d _a (min.)	D _a (max.)	D _b (max.)	r _a (max.)	r _b (max.)	EL	L	M	H	EL	L	M	H	EL	L	M	H	
139	171	174	1.5	0.8	327	652	1 466	2 943	111	148	213	301	- 10	- 20	- 38	- 61	1.50
139	171	174	1.5	0.8	358	734	1 682	3 410	128	172	249	352	- 10	- 20	- 38	- 61	1.29
139	171	174	1.5	0.8	470	1 008	2 126	4 280	264	348	462	612	- 7	- 14	- 25	- 41	1.54
139	171	174	1.5	0.8	525	1 153	2 465	5 001	307	408	543	722	- 7	- 14	- 25	- 41	1.33
139	171	174	1.5	0.8	98	718	1 420	—	80	162	212	—	0	- 20	- 35	—	1.48
139	171	174	1.5	0.8	98	813	1 635	—	89	189	248	—	0	- 20	- 35	—	1.27
139	171	174	1.5	0.8	98	982	1 899	—	134	293	372	—	0	- 16	- 27	—	1.48
139	171	174	1.5	0.8	98	1 123	2 199	—	150	343	437	—	0	- 16	- 27	—	1.27
140	190	194	2	1	493	970	2 252	4 518	126	167	244	343	- 16	- 29	- 54	- 85	3.22
140	190	194	2	1	551	1 105	2 605	5 265	146	195	285	403	- 16	- 29	- 54	- 85	2.77
140	190	194	2	1	821	1 535	3 407	6 842	316	396	537	710	- 12	- 20	- 36	- 58	3.66
140	190	194	2	1	935	1 772	3 974	8 025	369	466	632	839	- 12	- 20	- 36	- 58	3.21
140	190	194	2	1	98	1 494	4 721	7 942	202	508	772	943	0	- 15	- 35	- 50	3.26
140	190	194	2	1	98	739	1 522	—	82	168	223	—	0	- 20	- 36	—	3.41
140	190	194	2	1	98	837	1 754	—	92	196	261	—	0	- 20	- 36	—	3.19
140	190	194	2	1	98	1 013	1 964	—	137	304	386	—	0	- 16	- 27	—	3.41
140	190	194	2	1	98	1 159	2 276	—	154	356	454	—	0	- 16	- 27	—	3.19
144	216	223	2.5	1	749	1 506	3 386	6 740	136	182	261	364	- 20	- 39	- 73	- 116	6.23
144	216	223	2.5	1	1 189	2 452	5 569	10 929	337	438	597	783	- 15	- 28	- 52	- 83	6.22
144	216	223	2.5	1	559	3 764	9 804	13 576	339	660	942	1 068	- 5	- 30	- 60	- 75	6.28

Calculation of radial rigidity
Multiply axial rigidity by the appropriate factor in Table A.

Calculation of preload and axial rigidity for combined bearings
Multiply by the appropriate factor in Table B. For radial rigidity, multiply the value from Table A with the appropriate factor in Table B.

	EL	L	M	H
15°	6.5	6.0	5.0	4.5
18°		4.5		
25°		2.0		
30°		1.4		

	DBD	DBB
Preload factor	1.36	2
Axial rigidity	1.48	2
Radial rigidity	1.54	2

For additional information:

- Dynamic Equivalent Load ······P191
- Static Equivalent Load ······P198
- Spacer Dimensions and Nozzle Position ···P237
- Recommended Grease Quantities ···P257

1. Angular Contact Ball Bearings

Bore Diameter 140-150mm

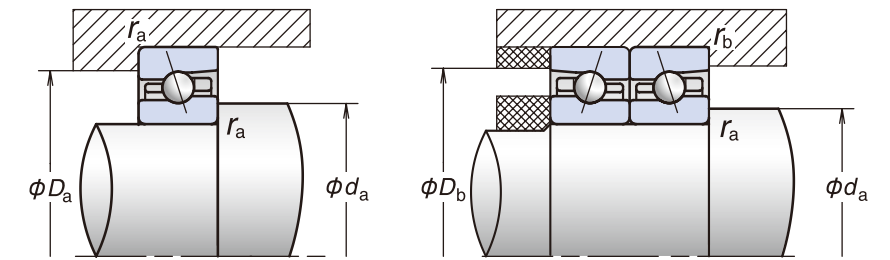
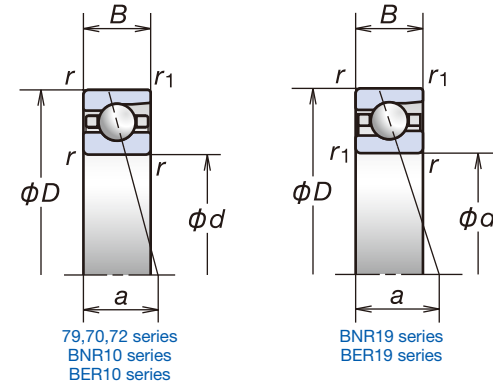

Designation	Boundary Dimensions (mm)					Basic Load Ratings (kN)		Permissible Axial Load (kN)	Contact Angle (°)	Factor f ₀	Effective Load Center (mm) a	Limiting Speeds (r/min)	
	d	D	B	r (min.)	r ₁ (min.)	C _r (Dynamic)	C _{0r} (Static)					Grease	Oil
7928C	140	190	24	1.5	1	100	95.5	58.0	15	16.7	34.1	7 000	10 700
7928CSN24	140	190	24	1.5	1	100	91.5	69.1	15	16.7	34.1	9 100	13 900
7928A5	140	190	24	1.5	1	94.5	90.0	68.0	25	—	50.5	6 100	9 100
7928A5SN24	140	190	24	1.5	1	94.5	86.5	80.7	25	—	50.5	7 900	11 900
140BNR19E	140	190	24	1.5	1	75.5	61.5	89.5	18	11.0	38.8	9 100	13 000
140BNR19H	140	190	24	1.5	1	75.5	59.0	58.5	18	11.0	38.8	11 000	17 000
140BER19E	140	190	24	1.5	1	72.5	59.0	105	25	—	50.5	7 900	11 100
140BER19H	140	190	24	1.5	1	72.5	56.5	70.5	25	—	50.5	9 700	15 200
7028C	140	210	33	2	1	166	145	90.0	15	16.0	39.9	6 600	10 000
7028CSN24	140	210	33	2	1	167	139	107	15	16.0	39.9	8 600	13 100
7028A5	140	210	33	2	1	157	138	104	25	—	57.3	5 800	8 600
7028A5SN24	140	210	33	2	1	157	132	124	25	—	57.3	7 500	11 200
7028A	140	210	33	2	1	151	133	80.5	30	—	67.0	4 300	5 800
140BNR10E	140	210	33	2	1	82.0	71.5	97.0	18	11.0	44.9	8 600	12 300
140BNR10H	140	210	33	2	1	82.0	68.5	63.5	18	11.0	44.9	10 300	16 000
140BER10E	140	210	33	2	1	78.5	68.5	113	25	—	57.3	7 400	10 400
140BER10H	140	210	33	2	1	78.5	65.5	76.5	25	—	57.3	9 200	14 300
7228C	140	250	42	3	1.1	300	254	172	15	14.8	47.1	5 900	9 000
7228A5	140	250	42	3	1.1	285	242	194	25	—	66.5	5 200	7 700
7228A	140	250	42	3	1.1	275	234	150	30	—	77.3	3 900	5 200
7930C	150	210	28	2	1	129	122	74.0	15	16.6	38.1	6 400	9 800
7930CSN24	150	210	28	2	1	129	117	87.9	15	16.6	38.1	8 400	12 700
7930A5	150	210	28	2	1	121	115	84.5	25	—	56.0	5 600	8 400
7930A5SN24	150	210	28	2	1	121	110	103	25	—	56.0	7 300	10 900
150BNR19S	150	210	28	2	1	97.0	78.5	114	18	10.8	43.2	7 800	11 200
150BNR19H	150	210	28	2	1	97.0	75.0	75.0	18	10.8	43.2	10 000	15 600
150BER19S	150	210	28	2	1	93.0	75.5	134	25	—	55.9	6 700	9 500
150BER19H	150	210	28	2	1	93.0	72.0	90.5	25	—	55.9	8 900	13 900
7030C	150	225	35	2.1	1.1	190	168	105	15	16.0	42.6	6 200	9 400
7030CSN24	150	225	35	2.1	1.1	190	161	125	15	16.0	42.6	8 000	12 200
7030A5	150	225	35	2.1	1.1	180	160	123	25	—	61.2	5 400	8 000
7030A5SN24	150	225	35	2.1	1.1	179	152	146	25	—	61.2	7 000	10 400
7030A	150	225	35	2.1	1.1	172	154	95.0	30	—	71.6	4 000	5 400
150BNR10S	150	225	35	2.1	1.1	96.5	84.0	114	18	11.0	48.0	7 500	10 700
150BNR10H	150	225	35	2.1	1.1	96.5	80.5	74.5	18	11.0	48.0	9 600	15 000
150BER10S	150	225	35	2.1	1.1	92.5	80.5	143	25	—	61.2	6 400	9 100
150BER10H	150	225	35	2.1	1.1	92.5	77.0	96.5	25	—	61.2	8 600	13 400
7230C	150	270	45	3	1.1	340	305	205	15	14.7	50.6	5 500	8 400
7230A5	150	270	45	3	1.1	325	290	231	25	—	71.5	4 800	7 200
7230A	150	270	45	3	1.1	315	280	179	30	—	83.1	3 600	4 800

(1) For details on permissible axial load, refer to Page 199.

(2) For details on limiting speeds, refer to Page 216. See Page 51 for cage differences and their impact on d_{mr}n values.

Abutment and Fillet Dimensions (mm)					Preload (DB and DF Arrangement) (N)				Axial Rigidity (DB and DF Arrangement) (N/μm)				Measured Axial Clearance (μm)				Mass (kg) (approx.)
d _a (min.)	D _a (max.)	D _b (max.)	r _a (max.)	r _b (max.)	EL	L	M	H	EL	L	M	H	EL	L	M	H	
149	181	184	1.5	0.8	334	632	1 459	2 967	115	150	217	308	-10	-19	-37	-60	1.63
149	181	184	1.5	0.8	366	711	1 673	3 438	132	174	254	361	-10	-19	-37	-60	1.41
149	181	184	1.5	0.8	482	950	2 200	4 436	273	349	480	636	-7	-13	-25	-41	1.63
149	181	184	1.5	0.8	539	1 086	2 552	5 185	317	409	564	749	-7	-13	-25	-41	1.41
149	181	184	1.5	0.8	98	739	1 522	—	82	168	223	—	0	-20	-36	—	1.57
149	181	184	1.5	0.8	98	837	1 754	—	92	196	261	—	0	-20	-36	—	1.35
149	181	184	1.5	0.8	98	1 013	1 964	—	137	304	386	—	0	-16	-27	—	1.57
149	181	184	1.5	0.8	98	1 159	2 276	—	154	356	454	—	0	-16	-27	—	1.35
150	200	204	2	1	503	998	2 332	4 785	131	174	254	361	-11	-24	-49	-81	3.41
150	200	204	2	1	543	1 113	2 662	5 527	150	201	296	422	-11	-24	-49	-81	2.94
150	200	204	2	1	787	1 516	3 444	6 817	320	406	554	729	-9	-17	-33	-54	3.87
150	200	204	2	1	873	1 721	3 979	7 947	371	474	651	859	-9	-17	-33	-54	3.40
150	200	204	2	1	196	1 782	5 273	8 717	262	557	829	1 006	0	-15	-35	-50	3.44
150	200	204	2	1	196	766	1 642	—	114	186	250	—	0	-15	-31	—	3.65
150	200	204	2	1	196	848	1 865	—	128	215	292	—	0	-15	-31	—	3.42
150	200	204	2	1	196	1 075	2 257	—	190	340	445	—	0	-13	-25	—	3.65
150	200	204	2	1	196	1 208	2 589	—	213	396	521	—	0	-13	-25	—	3.42
154	236	243	2.5	1	910	1 832	4 081	8 296	150	200	286	404	-24	-45	-82	-131	7.91
154	236	243	2.5	1	1 499	3 010	6 731	13 407	376	484	657	867	-18	-32	-58	-93	7.91
154	236	243	2.5	1	573	4 992	11 447	15 522	352	751	1 022	1 149	-5	-36	-65	-80	7.97
160	200	204	2	1	387	825	1 969	3 990	123	168	248	351	-7	-19	-41	-68	2.96
160	200	204	2	1	411	912	2 238	4 593	140	193	288	410	-7	-19	-41	-68	2.64
160	200	204	2	1	651	1 269	2 914	5 914	310	395	541	720	-7	-14	-28	-47	2.97
160	200	204	2	1	715	1 433	3 355	6 881	358	460	634	847	-7	-14	-28	-47	2.65
160	200	204	2	1	196	937	1 910	—	106	186	245	—	0	-20	-38	—	2.46
160	200	204	2	1	196	1 046	2 179	—	119	216	286	—	0	-20	-38	—	2.14
160	200	204	2	1	196	1 321	2 580	—	177	340	433	—	0	-17	-30	—	2.46
160	200	204	2	1	196	1 494	2 967	—	198	396	508	—	0	-17	-30	—	2.14
162	213	218	2	1	577	1 149	2 764	5 487	140	186	276	386	-13	-27	-55	-88	4.15
162	213	218	2	1	629	1 288	3 167	6 352	161	215	322	452	-13	-27	-55	-88	3.56
162	213	218	2	1	973	1 877	4 118	8 340	353	448	603	802	-11	-20	-37	-61	4.69
162	213	218	2	1	1089	2 142	4 771	9 741	410	524	709	945	-11	-20	-37	-61	4.10
162	213	218	2	1	196	1 828	5 852	11 679	268	574	877	1 145	0	-15	-37	-60	4.19
162	213	218	2	1	196	916	1 908	—	115	200	266	—	0	-18	-35	—	4.41
162	213	218	2	1	196	1 021	2 177	—	129	232	310	—	0	-18	-35	—	4.13
162	213	218	2	1	196	1 262	2 624	—	192	363	473	—	0	-15	-28	—	4.41
162	213	218	2	1	196	1 425	3 019	—	215	423	554	—	0	-15	-28	—	4.13
164	256	263	2.5	1	1 093	2 203	4 952	9 979	165	220	316	444	-28	-51	-92	-145	11.10
164	256	263	2.5	1	1 854	3 642	8 044	16 467	417	533	720	961	-21	-36	-64	-104	11.10
164	256	263	2.5	1	587	5 000	11 917	16 154	366	772	1 063	1 194	-5	-35	-65	-80	11.20

Calculation of radial rigidity
Multiply axial rigidity by the appropriate factor in Table A.

Calculation of preload and axial rigidity for combined bearings
Multiply by the appropriate factor in Table B. For radial rigidity, multiply the value from Table A with the appropriate factor in Table B.

Table A	EL	L	M	H
15°	6.5	6.0	5.0	4.5
18°		4.5		
25°		2.0		
30°		1.4		

Table B	DBD	DBB
---------	-----	-----

1. Angular Contact Ball Bearings

Bore Diameter **160-180mm**

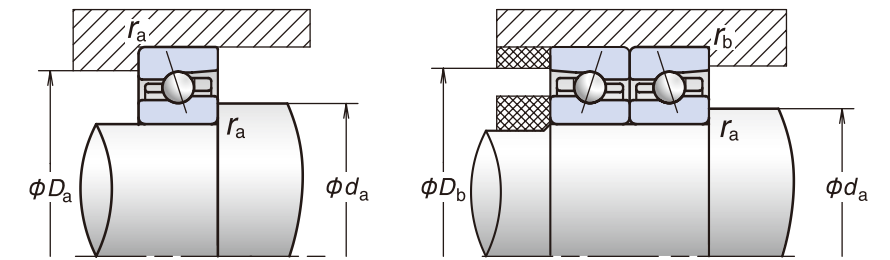
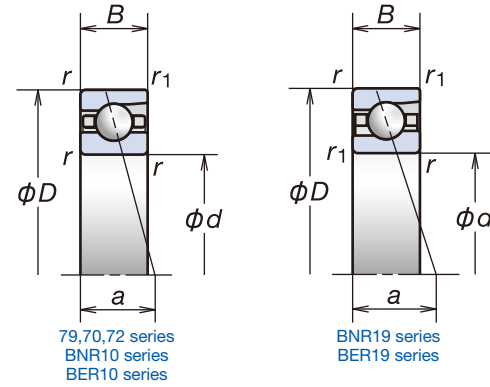

Designation	Boundary Dimensions (mm)					Basic Load Ratings (kN)		Permissible Axial Load (kN)	Contact Angle (°)	Factor f_0	Effective Load Center (mm)	Limiting Speeds (min ⁻¹)	
	d	D	B	r (min.)	r_1 (min.)	C_r (Dynamic)	C_{or} (Static)					Grease	Oil
7932C	160	220	28	2	1	134	133	80.0	15	16.7	39.4	5 600	8 700
7932CSN24	160	220	28	2	1	134	127	94.8	15	16.7	39.4	7 400	11 500
7932A5	160	220	28	2	1	126	125	93.5	25	—	58.3	4 800	7 400
7932A5SN24	160	220	28	2	1	126	120	111	25	—	58.3	6 400	9 800
160BNR19S	160	220	28	2	1	101	85.5	124	18	10.9	44.9	6 900	10 000
160BNR19H	160	220	28	2	1	101	81.5	81.5	18	10.9	44.9	9 000	14 300
160BER19S	160	220	28	2	1	96.5	82.0	146	25	—	58.3	5 800	8 500
160BER19H	160	220	28	2	1	96.5	78.5	98.5	25	—	58.3	7 900	12 700
7032C	160	240	38	2.1	1.1	215	193	118	15	16.0	45.8	5 300	8 300
7032CSN24	160	240	38	2.1	1.1	216	185	140	15	16.0	45.8	7 000	10 900
7032A5	160	240	38	2.1	1.1	204	183	138	25	—	65.6	4 500	7 000
7032A5SN24	160	240	38	2.1	1.1	204	176	168	25	—	65.6	6 000	9 300
7032A	160	240	38	2.1	1.1	195	176	106	30	—	76.7	3 300	4 500
160BNR10S	160	240	38	2.1	1.1	105	92.5	134	18	11.0	51.5	6 500	9 500
160BNR10H	160	240	38	2.1	1.1	105	88.5	88.0	18	11.0	51.5	8 500	13 500
160BER10S	160	240	38	2.1	1.1	100	88.5	158	25	—	65.6	5 500	8 000
160BER10H	160	240	38	2.1	1.1	100	84.5	106	25	—	65.6	7 500	12 000
7232A	160	290	48	3	1.1	330	305	195	30	—	89	2 900	4 000
7934C	170	230	28	2	1	142	148	88.5	15	16.8	40.8	5 300	8 300
7934CSN24	170	230	28	2	1	142	142	105	15	16.8	40.8	7 000	10 900
7934A5	170	230	28	2	1	134	140	103	25	—	60.6	4 500	7 000
7934A5SN24	170	230	28	2	1	134	134	124	25	—	60.6	6 000	9 300
170BNR19S	170	230	28	2	1	107	95.5	104	18	11.0	46.5	6 500	9 500
170BNR19H	170	230	28	2	1	107	91.5	91.0	18	11.0	46.5	8 500	13 500
170BER19S	170	230	28	2	1	102	91.5	163	25	—	60.6	5 500	8 000
170BER19H	170	230	28	2	1	102	87.5	110	25	—	60.6	7 500	12 000
7034C	170	260	42	2.1	1.1	258	234	149	15	15.9	49.8	4 900	7 700
7034A5	170	260	42	2.1	1.1	244	223	168	25	—	71.1	4 200	6 600
7034A	170	260	42	2.1	1.1	234	214	129	30	—	83.1	3 100	4 200
7234C	170	310	52	4	1.5	405	390	265	15	14.7	58.2	4 400	6 900
7234A	170	310	52	4	1.5	370	360	231	30	—	95.3	2 800	3 800
7936C	180	250	33	2	1	183	184	111	15	16.6	45.3	4 900	7 700
7936CSN24	180	250	33	2	1	183	177	132	15	16.6	45.3	6 600	10 200
7936A5	180	250	33	2	1	172	174	128	25	—	66.6	4 200	6 600
7936A5SN24	180	250	33	2	1	173	167	152	25	—	66.6	5 600	8 700
180BNR19S	180	250	33	2	1	138	119	173	18	10.9	51.4	6 100	8 900
180BNR19H	180	250	33	2	1	138	114	114	18	10.9	51.4	8 000	12 600
180BER19S	180	250	33	2	1	132	114	203	25	—	66.6	5 200	7 500
180BER19H	180	250	33	2	1	132	109	137	25	—	66.6	7 000	11 200
7036C	180	280	46	2.1	1.1	287	276	175	15	15.8	53.8	4 600	7 200
7036A5	180	280	46	2.1	1.1	272	262	195	25	—	76.6	4 000	6 100
7036A	180	280	46	2.1	1.1	261	252	151	30	—	89.4	2 900	4 000
7236A	180	320	52	4	1.5	385	385	246	30	—	98.2	2 600	3 600

(1) For details on permissible axial load, refer to Page 199.

(2) For details on limiting speeds, refer to Page 216. See Page 51 for cage differences and their impact on $d_{gr}n$ values.

Abutment and Fillet Dimensions (mm)					Preload (DB and DF Arrangement) (N)				Axial Rigidity (DB and DF Arrangement) (N/μm)				Measured Axial Clearance (μm)				Mass (kg) (approx.)
d_a (min.)	D_a (max.)	D_b (max.)	r_a (max.)	r_b (max.)	EL	L	M	H	EL	L	M	H	EL	L	M	H	
170	210	214	2	1	431	863	1 954	3 882	134	179	258	360	- 8	- 19	- 39	- 64	3.10
170	210	214	2	1	461	956	2 222	4 469	153	206	299	420	- 8	- 19	- 39	- 64	2.75
170	210	214	2	1	678	1 340	3 252	6 333	330	423	592	774	- 7	- 14	- 29	- 47	3.12
170	210	214	2	1	747	1 516	3 753	7 375	382	493	695	912	- 7	- 14	- 29	- 47	2.77
170	210	214	2	1	196	1 035	2 093	—	112	203	266	—	0	- 21	- 39	—	2.65
170	210	214	2	1	196	1 159	2 392	—	125	235	311	—	0	- 21	- 39	—	2.31
170	210	214	2	1	196	1 396	2 747	—	186	364	465	—	0	- 17	- 30	—	2.65
170	210	214	2	1	196	1 581	3 163	—	208	425	546	—	0	- 17	- 30	—	2.31
172	228	233	2	1	623	1 270	2 968	5 798	147	197	288	399	- 14	- 29	- 57	- 90	5.11
172	228	233	2	1	681	1 429	3 407	6 718	169	229	336	468	- 14	- 29	- 57	- 90	4.29
172	228	233	2	1	1 090	2 168	4 725	9 446	376	483	649	858	- 12	- 22	- 40	- 65	5.71
172	228	233	2	1	1 225	2 484	5 485	11 045	438	566	764	1 012	- 12	- 22	- 40	- 65	4.99
172	228	233	2	1	196	1 883	5 601	12 072	276	594	882	1 183	0	- 15	- 35	- 60	5.16
172	228	233	2	1	196	1 085	2 284	—	117	216	288	—	0	- 21	- 40	—	5.50
172	228	233	2	1	196	1 217	2 616	—	131	251	337	—	0	- 21	- 40	—	5.20
172	228	233	2	1	196	1 470	3 039	—	195	388	505	—	0	- 17	- 31	—	5.50
172	228	233	2	1	196	1 668	3 506	—	218	453	593	—	0	- 17	- 31	—	5.20
174	276	283	2.5	1	1 120	4 154	15 301	23 729	464	733	1 185	1 405	- 10	- 30	- 76	- 102	14.1
180	220	224	2	1	486	968	2 186	4 334	150	200	287	400	- 9	- 20	- 40	- 65	3.36
180	220	224	2	1	524	1 079	2 492	4 998	172	231	334	468	- 9	- 20	- 40	- 65	2.97
180	220	224	2	1	812	1 564	3 553	7 173	377	478	653	867	- 8	- 15	- 29	- 48	3.36
180	220	224	2	1	902	1 777	4 106	8 365	437	558	767	1 021	- 8	- 15	- 29	- 48	2.97
180	220	224	2	1	196	1 166	2 346	—	120	226	297	—	0	- 22	- 40	—	2.86
180	220	224	2	1	196	1 311	2 689	—	134	263	346	—	0	- 22	- 40	—	2.47
180	220	224	2	1	196	1 507	3 126	—	199	400	521	—	0	- 17	- 31	—	2.86
180	220	224	2	1	196	1 712	3 609	—	223	468	612	—	0	- 17	- 31	—	2.47
182	248	253	2	1	777	1 572	3 598	7 104	160	214	309	431	- 18	- 35	- 66	- 104	6.88
182	248	253	2	1	1 292	2 555	5 927	11 666	401	514	708	930	- 14	- 25	- 47	- 75	7.83
182	248	253	2	1	196	2 697	6 086	12 116	278	678	910	1 181	0	- 20	- 37	- 60	6.94
188	292	301	3	1.5	1 493	3 005	6 205	12 460	192	256	354	496	- 36	- 63	- 105	- 164	19.4
188	292	301	3	1.5	1 394	6 746	17 921	28 082	512	890	1 278	1 522	- 12	- 42	- 83	- 112	17.3
190	240	244	2	1	591	1 138	2 659	5 370	158	206	301	423	- 12	- 24	- 48	- 78	4.90
190	240	244	2	1	645	1 276	3 047	6 217	181	239	351	496	- 12	- 24	- 48	- 78	4.33
190	240	244	2	1	990	2 017	4 440	8 876	397	514	694	917	- 10	- 19	- 35	- 57	4.94
190	240	244	2	1	1 108	2 307	5 150	10 373	461	602	816	1 081	- 10	- 19	- 35	- 57	4.37
190	240	244	2	1	196	1 427	2 958	—	118	239	317	—	0	- 27	- 49	—	4.17
190	240	244	2	1	196	1 617	3 408	—	132	278	371	—	0	- 27	- 49	—	3.60
190	240	244	2	1	196	1 887	3 847	—	196	426	551	—	0	- 21	- 37	—	4.17
190	240	244	2	1	196	2 156	4 456	—	220	498	648	—	0	- 21	- 37	—	3.60
192	268	273	2	1	938	1 880	4 201	8 277	179	239	342	475	- 21	- 39	- 71	- 111	10.4

1. Angular Contact Ball Bearings

Bore Diameter **190-260mm**

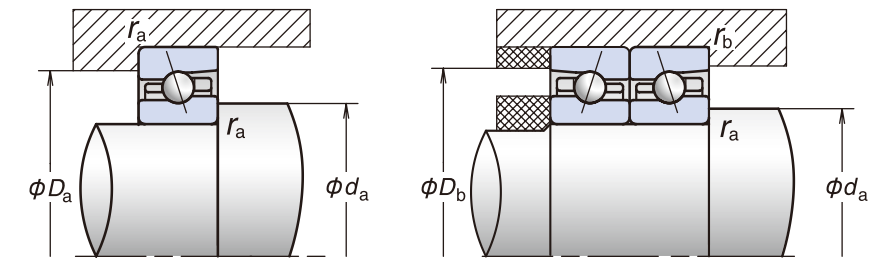
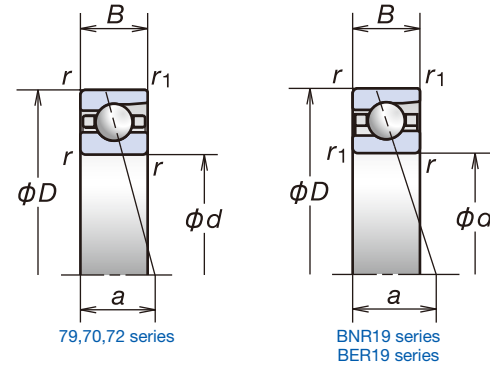

Designation	Boundary Dimensions (mm)					Basic Load Ratings (kN)		Permissible Axial Load (kN)	Contact Angle (°)	Factor f_0	Effective Load Center (mm) a	Limiting Speeds (min ⁻¹)	
	d	D	B	r (min.)	r_1 (min.)	C_r (Dynamic)	C_{or} (Static)					Grease	Oil
7938C	190	260	33	2	1	185	192	115	15	16.7	46.6	4 700	7 400
7938CSN24	190	260	33	2	1	186	184	137	15	16.7	46.6	6 300	9 700
7938A5	190	260	33	2	1	175	182	131	25	—	69.0	4 000	6 300
7938A5SN24	190	260	33	2	1	175	174	158	25	—	69.0	5 400	8 300
190BNR19S	190	260	33	2	1	140	124	181	18	10.9	53.1	5 800	8 500
190BNR19H	190	260	33	2	1	140	119	119	18	10.9	53.1	7 600	12 000
190BER19S	190	260	33	2	1	134	119	212	25	—	69.0	4 900	7 200
190BER19H	190	260	33	2	1	134	114	143	25	—	69.0	6 700	10 700
7038C	190	290	46	2.1	1.1	310	305	192	15	15.9	55.2	4 400	6 900
7038A5	190	290	46	2.1	1.1	294	291	222	25	—	79.0	3 800	5 900
7038A	190	290	46	2.1	1.1	282	280	172	30	—	92.3	2 800	3 800
7238C	190	340	55	4	1.5	435	450	293	15	15.2	63.0	4 000	6 300
7238A	190	340	55	4	1.5	395	410	261	30	—	104.0	2 500	3 400
7940C	200	280	38	2.1	1.1	238	244	144	15	16.5	51.2	4 400	6 900
7940CSN24	200	280	38	2.1	1.1	239	234	171	15	16.5	51.2	5 900	9 100
7940A5	200	280	38	2.1	1.1	225	231	170	25	—	75.0	3 800	5 900
7940A5SN24	200	280	38	2.1	1.1	225	222	202	25	—	75.0	5 000	7 800
200BNR19S	200	280	38	2.1	1.1	179	157	229	18	10.8	58.0	5 500	8 000
200BNR19H	200	280	38	2.1	1.1	179	150	150	18	10.8	58.0	7 100	11 300
200BER19S	200	280	38	2.1	1.1	172	151	269	25	—	75.0	4 600	6 700
200BER19H	200	280	38	2.1	1.1	172	144	181	25	—	75.0	6 300	10 000
7040C	200	310	51	2.1	1.1	335	340	213	15	15.9	59.7	4 200	6 500
7040A5	200	310	51	2.1	1.1	315	325	245	25	—	85.0	3 600	5 500
7040A	200	310	51	2.1	1.1	305	310	190	30	—	99.1	2 600	3 600
7240C	200	360	58	4	1.5	465	490	320	15	15.1	66.5	3 800	5 900
7240A	200	360	58	4	1.5	425	450	281	30	—	109.8	2 400	3 300
7944C	220	300	38	2.1	1.1	240	256	150	15	16.7	53.8	4 100	6 400
7944CSN24	220	300	38	2.1	1.1	240	246	178	15	16.7	53.8	5 400	8 400
7944A5	220	300	38	2.1	1.1	226	242	176	25	—	79.6	3 500	5 400
7944A5SN24	220	300	38	2.1	1.1	226	232	117	25	—	79.6	4 700	7 200
7044C	220	340	56	3	1.1	390	430	266	15	15.9	65.5	3 800	5 900
7044A	220	340	56	3	1.1	355	395	235	30	—	108.8	2 400	3 300
7244A	220	400	65	4	1.5	515	585	385	30	—	122.0	2 100	3 000
7948C	240	320	38	2.1	1.1	252	286	166	15	16.8	56.5	3 800	5 900
7948CSN24	240	320	38	2.1	1.1	253	274	197	15	16.8	56.5	5 000	7 800
7948A5	240	320	38	2.1	1.1	238	270	195	25	—	84.3	3 300	5 000
7948A5SN24	240	320	38	2.1	1.1	238	259	231	25	—	84.3	4 300	6 700
7048C	240	360	56	3	1.1	415	475	292	15	15.9	68.2	3 500	5 500
7048A	240	360	56	3	1.1	380	430	265	30	—	114.6	2 200	3 000
7952C	260	360	46	2.1	1.1	320	365	350	15	16.6	64.5	3 400	5 400
7952A5	260	360	46	2.1	1.1	305	345	255	25	—	95.3	3 000	4 600
7052A5	260	400	65	4	1.5	455	545	420	25	—	109.4	2 800	4 300
7052A	260	400	65	4	1.5	435	525	325	30	—	127.8	2 000	2 800
7252A	260	480	80	5	2	600	750	475	30	—	146.8	1 800	2 500

(1) For details on permissible axial load, refer to Page 199.

(2) For details on limiting speeds, refer to Page 216. See Page 51 for cage differences and their impact on $d_{gr}n$ values.

Abutment and Fillet Dimensions (mm)					Preload (DB and DF Arrangement) (N)				Axial Rigidity (DB and DF Arrangement) (N/μm)				Measured Axial Clearance (μm)				Mass (kg) (approx.)
d_a (min.)	D_a (max.)	D_b (max.)	r_a (max.)	r_b (max.)	EL	L	M	H	EL	L	M	H	EL	L	M	H	
200	250	254	2	1	602	1 219	2 815	5 649	163	217	315	442	-12	-25	-49	-79	4.98
200	250	254	2	1	657	1 370	3 228	6 543	187	252	368	518	-12	-25	-49	-79	4.38
200	250	254	2	1	1 013	2 075	4 582	9 175	410	531	718	950	-10	-19	-35	-57	5.12
200	250	254	2	1	1 136	2 375	5 318	10 726	476	622	845	1 120	-10	-19	-35	-57	4.52
200	250	254	2	1	196	1 466	3 049	—	120	247	328	—	0	-27	-49	—	4.38
200	250	254	2	1	196	1 661	3 512	—	135	288	384	—	0	-27	-49	—	3.78
200	250	254	2	1	196	2 052	4 112	—	201	449	578	—	0	-22	-38	—	4.38
200	250	254	2	1	196	2 349	4 768	—	226	526	679	—	0	-22	-38	—	3.78
202	278	283	2	1	1 042	2 087	4 682	9 306	189	251	360	502	-23	-42	-76	-119	11.2
202	278	283	2	1	1 723	3 640	7 610	15 239	472	619	820	1 084	-17	-31	-53	-85	11.2
202	278	283	2	1	196	3 890	8 161	16 183	287	819	1 073	1 390	0	-25	-43	-69	11.3
208	322	331	3	1.5	1 680	3 382	6 984	14 023	216	288	398	558	-37	-64	-106	-165	22.2
208	322	331	3	1.5	1 520	7 758	20 405	31 456	570	1 009	1 445	1 710	-12	-43	-84	-112	22.4
212	268	273	2	1	784	1 584	3 592	7 168	183	244	351	492	-16	-31	-58	-92	5.95
212	268	273	2	1	867	1 794	4 138	8 330	211	284	411	577	-16	-31	-58	-92	5.07
212	268	273	2	1	1 256	2 554	5 855	11 667	451	584	800	1 056	-12	-22	-41	-66	5.95
212	268	273	2	1	1 418	2 938	6 817	13 669	526	685	942	1 247	-12	-22	-41	-66	5.07
212	268	273	2	1	196	1 888	3 887	—	123	275	364	—	0	-33	-58	—	5.95
212	268	273	2	1	196	2 156	4 499	—	138	321	427	—	0	-33	-58	—	5.07
212	268	273	2	1	196	2 581	5 136	—	206	496	636	—	0	-26	-44	—	5.95
212	268	273	2	1	196	2 970	5 974	—	230	582	749	—	0	-26	-44	—	5.07
212	298	303	2	1	1 153	2 310	5 202	10 293	198	264	379	527	-25	-45	-81	-126	13.6
212	298	303	2	1	1 876	3 710	8 392	16 917	493	632	861	1 141	-18	-31	-56	-90	13.7
212	298	303	2	1	196	5 065	13 451	26 693	302	913	1 310	1 711	0	-30	-60	-95	13.7
218	342	351	3	1.5	1 811	3 665	7 583	15 074	219	292	404	564	-40	-69	-114	-176	26.3
218	342	351	3	1.5	1 641	8 371	22 145	34 607	577	1 023	1 467	1 746	-13	-46	-90	-121	26.5
232	288	293	2	1	848	1 690	3 793	7 530	193	256	367	513	-17	-32	-59	-93	7.50
232	288	293	2	1	941	1 918	4 374	8 755	222	297	430	603	-17	-32	-59	-93	6.58
232	288	293	2	1	1 288	2 631	6 047	12 067	465	604	828	1 094	-12	-22	-41	-66	7.50
232	288	293	2	1	1 456	3 028	7 044	14 142	544	709	976	1 292	-12	-22	-41	-66	6.58
234	326	333	2.5	1	1 443	2 907	6 509	13 026	228	304	435	609	-29	-51	-90	-140	18.5
234	326	333	2.5	1	1 402	7 065	18 373	29 052	618	1 091	1 555	1 858	-10	-36	-70	-95	18.5
238	382	391	3	1.5	2 187	11 037	28 837	44 290	661	1 167	1 666	1 967	—	—	—	—	36.5
252	308	313	2	1	902	1 822	4 129	8 237	210	280	403	565	-17	-32	-59	-93	8.30
252	308	313	2	1	1 004	2 072	4 769	9 589	243	326	473	664	-17	-32	-59	-93	7.29
252	308	313	2	1	1 385	2 860	6 622	13 265	511	664	913	1 208	-12	-22	-41	-66	8.30
252	308	313	2	1	1 569	3 296	7 721	15 556	596	780	1 076	1 426	-12	-22	-41	-66	7.29
254	346	353	2.5	1	1 699	3 337	7 134	14 212	244	324	455	636	-33	-56	-95	-147	19.3
254	346	353	2.5	1	1 584	7 755	20 305	31 460	653	1 141	1 631	1 934	-11	-38	-74	-99	19.3
272	348	353	2	1	1 187	2 376	5 327	1									

1. Angular Contact Ball Bearings

Bore Diameter **280-420mm**

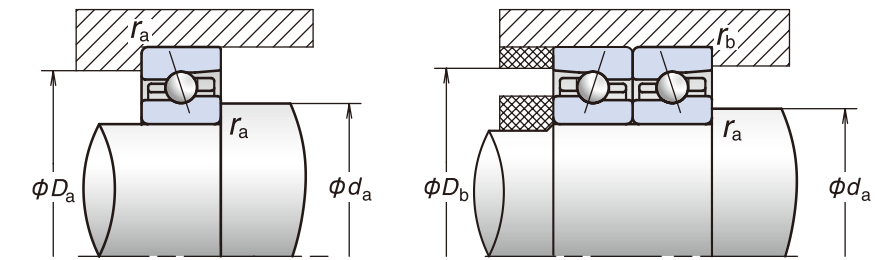
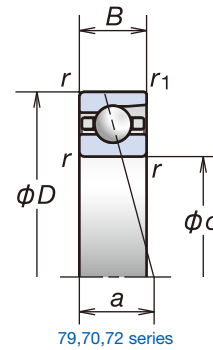

Designation	Boundary Dimensions (mm)					Basic Load Ratings (kN)		Permissible Axial Load (kN)	Contact Angle (°)	Factor f_0	Effective Load Center (mm) a	Limiting Speeds (min ⁻¹)	
	d	D	B	r (min.)	r_1 (min.)	C_r (Dynamic)	C_{or} (Static)					Grease	Oil
7956C	280	380	46	2.1	1.1	340	410	390	15	16.7	67.2	3 200	5 000
7956A5	280	380	46	2.1	1.1	325	390	286	25	—	99.9	2 800	4 300
7056A	280	420	65	4	1.5	430	530	325	30	—	133.5	1 900	2 600
7960C	300	420	56	3	1.1	435	550	530	15	16.4	76.2	3 000	4 600
7960A5	300	420	56	3	1.1	410	520	395	25	—	111.9	2 500	3 900
7960A	300	420	56	3	1.1	395	500	300	30	—	131.9	1 900	2 500
7060C	300	460	74	4	1.5	535	660	415	15	15.9	87.9	2 800	4 400
7060A	300	460	74	4	1.5	485	605	365	30	—	146.7	1 800	2 400
7964C	320	440	56	3	1.5	440	575	350	15	16.6	78.9	2 800	4 400
7964A5	320	440	56	3	1.5	415	545	405	25	—	116.6	2 400	3 700
7964A	320	440	56	3	1.5	400	525	310	30	—	137.7	1 800	2 400
7064A	320	480	74	4	1.5	585	795	500	30	—	152.5	1 700	2 300
7264A	320	580	92	5	2	795	1 120	655	30	—	175.9	1 500	2 000
7968C	340	460	56	3	1.1	460	625	375	15	16.7	81.6	2 700	4 200
7968A5	340	460	56	3	1.1	430	590	435	25	—	121.3	2 300	3 500
7968A	340	460	56	3	1.1	415	565	335	30	—	143.5	1 700	2 300
7068A	340	520	82	5	2	655	905	560	30	—	165.1	1 600	2 100
7268A	340	620	92	6	3	850	1 260	780	30	—	184.6	1 400	1 900
7972A5	360	480	56	3	1.1	435	615	450	25	—	125.9	2 200	3 400
7072A5	360	540	82	5	2	700	995	750	25	—	145.9	2 000	3 200
7072A	360	540	82	5	2	670	960	575	30	—	170.9	1 500	2 000
7976A	380	520	65	4	1.5	490	725	430	30	—	157.9	1 500	2 000
7980A	400	540	65	4	1.5	495	750	445	30	—	168.2	1 400	2 000
7080A	400	600	90	5	2	700	1 010	612	30	—	189.3	1 300	1 800
7984C	420	560	65	4	1.5	570	890	525	15	16.9	98.1	2 200	3 400
7984A	420	560	65	4	1.5	515	805	475	30	—	174.0	1 400	1 900
7084A	420	620	90	5	2	770	1 190	725	30	—	195.1	1 300	1 800

(¹) For details on permissible axial load, refer to Page 199.
 (²) For details on limiting speeds, refer to Page 216.

Abutment and Fillet Dimensions (mm)					Preload (DB and DF Arrangement) (N)				Axial Rigidity (DB and DF Arrangement) (N/μm)				Measured Axial Clearance (μm)				Mass (kg) (approx.)
d_a (min.)	D_a (max.)	D_b (max.)	r_a (max.)	r_b (max.)	EL	L	M	H	EL	L	M	H	EL	L	M	H	
292	368	373	2	1	1 334	2 668	5 977	12 032	241	321	459	645	—	—	—	—	15.0
292	368	373	2	1	2 147	4 379	9 870	18 954	589	766	1 046	1 372	—	—	—	—	15.0
298	402	411	3	1.5	1 834	9 136	19 408	38 390	693	1 217	1 603	2 089	—	—	—	—	31.2
314	406	413	2.5	1	1 931	3 880	7 832	15 388	278	371	507	703	—	—	—	—	24.4
314	406	413	2.5	1	2 821	5 674	12 747	25 563	669	859	1 164	1 538	—	—	—	—	24.4
314	406	413	2.5	1	1 670	8 238	16 993	35 209	721	1 262	1 646	2 178	—	—	—	—	24.4
318	442	451	3	1.5	2 320	4 610	9 591	19 107	262	348	482	673	—	—	—	—	44.9
318	442	451	3	1.5	2 039	10 839	21 816	44 468	685	1 231	1 593	2 096	—	—	—	—	44.9
334	426	431	2.5	1.5	1 863	3 839	8 134	16 349	280	377	527	739	—	—	—	—	25.7
334	426	431	2.5	1.5	3 281	6 117	12 940	24 591	717	899	1 194	1 543	—	—	—	—	25.9
334	426	431	2.5	1.5	1 735	8 555	17 647	36 566	749	1 310	1 709	2 262	—	—	—	—	25.9
338	462	471	3	1.5	2 832	14 291	37 339	57 347	856	1 511	2 157	2 547	—	—	—	—	47.2
342	558	570	4	2	3 839	20 397	53 741	83 944	893	1 604	2 298	2 733	—	—	—	—	110
354	446	453	2.5	1	2 002	4 123	8 736	17 561	301	405	566	793	—	—	—	—	27.2
354	446	453	2.5	1	3 147	5 631	13 580	26 414	739	912	1 271	1 657	—	—	—	—	27.2
354	446	453	2.5	1	1 863	9 190	18 955	39 276	804	1 407	1 836	2 429	—	—	—	—	27.2
362	498	510	4	2	3 163	16 035	42 344	66 484	869	1 536	2 201	2 622	—	—	—	—	60.5
368	592	606	5	2.5	4 293	22 810	61 387	95 407	998	1 793	2 590	3 075	—	—	—	—	128
374	466	473	2.5	1	3 256	6 797	14 379	27 326	765	999	1 326	1 714	—	—	—	—	27.9
382	518	530	4	2	5 851	11 710	23 743	46 950	851	1 095	1 431	1 878	—	—	—	—	62.4
382	518	530	4	2	3 321	15 254	43 314	68 443	913	1 556	2 288	2 732	—	—	—	—	62.4
398	502	511	3	1.5	2 419	12 046	25 063	50 619	914	1 605	2 101	2 754	—	—	—	—	39.8
418	522	531	3	1.5	2 502	12 461	25 928	52 366	946	1 661	2 174	2 850	—	—	—	—	42.1
422	578	590	4	2	3 649	18 229	36 022	74 336	883	1 553	1 995	2 637	—	—	—	—	85.9
438	542	551	3	1.5	1 102	2 153	12 382	24 643	262	337	707	987	—	—	—	—	44.0
438	542	551	3	1.5	2 669	10 733	27 658	55 859	1 009	1 640	2 319	3 040	—	—	—	—	44.0
442	598	610	4	2	4 003	21 269	42 028	86 731	1 008	1 812	2 328	3 077	—	—	—	—	90.3

Calculation of radial rigidity
 Multiply axial rigidity by the appropriate factor in Table A.

Calculation of preload and axial rigidity for combined bearings
 Multiply by the appropriate factor in Table B. For radial rigidity, multiply the value from Table A with the appropriate factor in Table B.

	EL	L	M	H
15°	6.5	6.0	5.0	4.5
25°	2.0			
30°	1.4			

	DBD	DBE
Preload factor	1.36	2
Axial rigidity	1.48	2
Radial rigidity	1.54	2

For additional information:

- Dynamic Equivalent Load ······P191
- Static Equivalent Load ······P198
- Spacer Dimensions and Nozzle Position ···P237
- Recommended Grease Quantities ···P257



Single-Row Cylindrical Roller Bearings

Standard Series



Ultra High-Speed Single-Row Cylindrical Roller Bearings
NSKROBUST™ Series

BASIC Series

Low Heat Generation Series



Double-Row Cylindrical Roller Bearings

High Rigidity Series

Low Heat Generation Series

Cylindrical Roller Bearings

Cylindrical Roller Bearings110-127

Features

Numbering System

Bearing Tables

- Single-Row Cylindrical Roller Bearings (Standard Series)
- Ultra High-Speed Single-Row Cylindrical Roller Bearings (NSKROBUST Series)
- Double-Row Cylindrical Roller Bearings

Cylindrical Roller Bearings

Features

Cylindrical roller bearings (CRBs) feature higher radial rigidity and can take higher radial loads than ball bearings; this makes them especially suitable for applications that require high rigidity such as lathe spindles, and for use as rear end bearings subjected to large belt loads.

The optimized internal design and cage shape of NSK cylindrical roller bearings achieve low heat generation and stable operation in high-speed applications.

Double-row cylindrical roller bearings are also available with the "E44" oil lubrication specification providing lubrication holes and an oil groove in the center of the outer ring.

Type Differences

NN-type cylindrical roller bearings feature ribs on the inner rings, while the ribs of NNU-type bearings are on the outer ring. NN-type bearings are used widely for their versatility; under grease lubrication, they provide a short run-in period, while under oil lubrication, their design prevents oil from overaccumulating within.

Type	Dimension Series	Series	Cage	Bore diameter																															
				25	30	35	40	45	50	55	60	65	70	75	80	85	90	95	100	105	110	120	130	140	150	160	170	180	190	200	220	240	260	280	
N	10	—	MR																																
		RS, RX	TP																																
NN	30	—	MB																																
			TB																																
		39	MB																																
	49	—	MB																																
NNU	49	—	MB																																

For details on NSKHPS and APTSURF bearings, see p. 29

Bore Specifications and Lubrication Holes

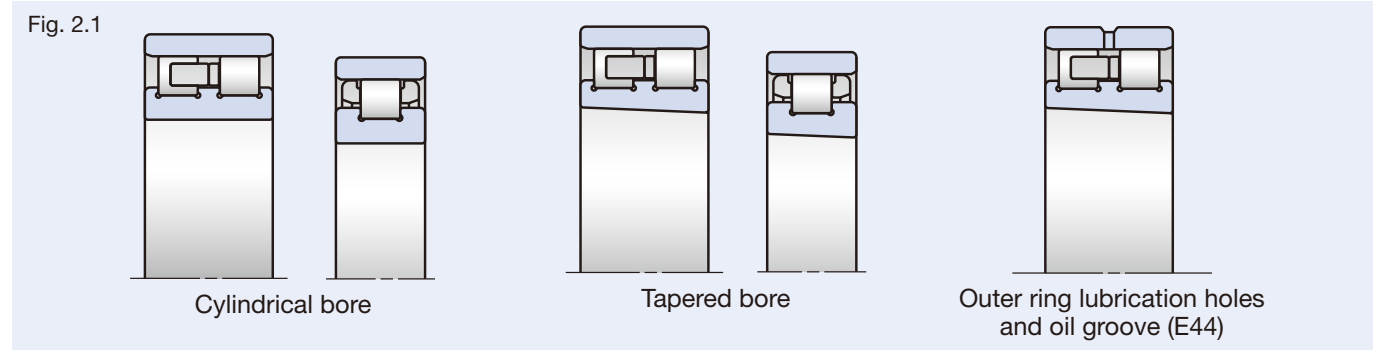

Both cylindrical bore and tapered bores are available. NSK recommends tapered bores as they help to prevent clearance variation by allowing for adjustments of radial internal clearance after mounting.

Bearing Types and Dimension Series

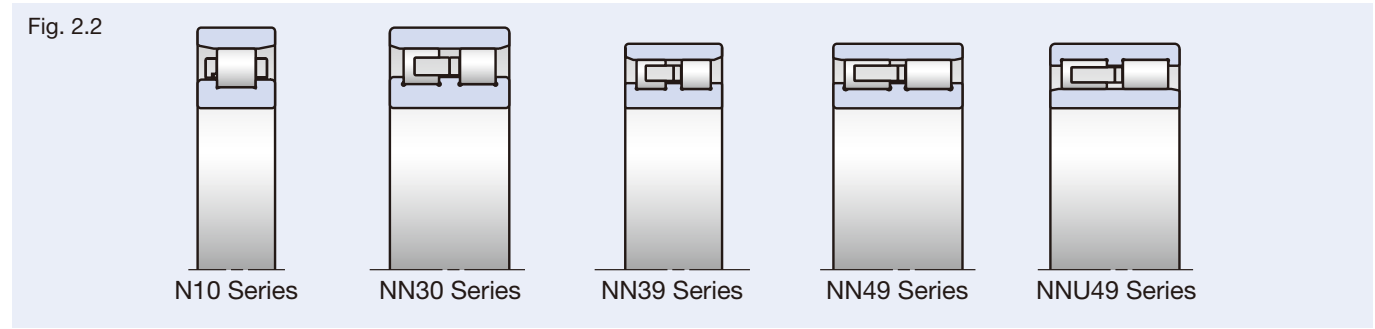

Numbering System for Single-Row Cylindrical Roller Bearings (Standard Series and NSKROBUST Series)

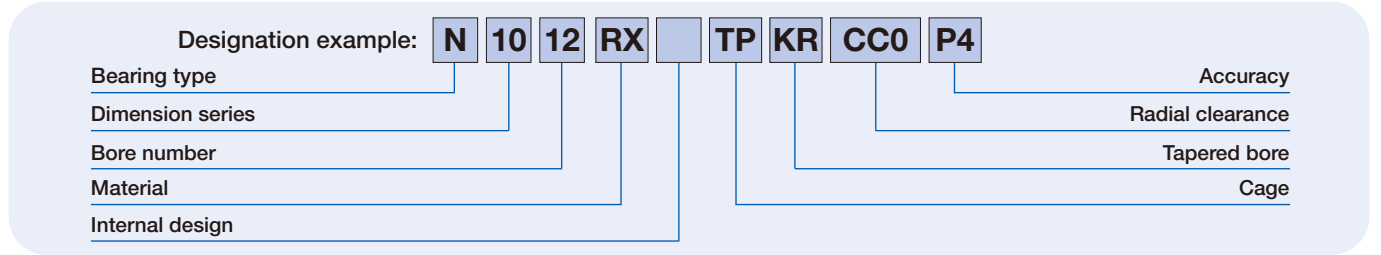

Code	Property	Description	Reference pages	
N	Bearing type	N: Single-row CRB (inner ring rib type)	46-47, 110	
10	Dimension series	10: 10 Series	46-47, 110	
12	Bore number	Bearing bore = Bore number × 5 (mm)	112-115	
RX	Material	No code: Standard CRB (material of inner and outer ring and rollers: SUJ2 bearing steel) RS, RX: Ultra high-speed single-row CRB (NSKROBUST Series)	14-15 28-29	
		Type		Material
		RS		Bearing steel (SUJ2)
	RX	Heat resistant steel for highspeed operation (SHX)	Heat resistant steel for highspeed operation (SHX)	
Z	Internal design	No code: Standard type Z: Low heat generation type	112-115	
TP	Cage	TP: Outer ring guided PEEK cage No code: Rib guided brass cage	19, 28-29	
		MR: Roller guided brass cage		
KR	Tapered bore	No code: Cylindrical bore KR (K): 1/12 Tapered bore	226-227	
CC0	Radial clearance	CC1: Standard clearance for cylindrical bore (Non-interchangeable)	46-47 112-115	
		CC0: Standard clearance for tapered bore (Non-interchangeable)		
		CCG: Special radial clearance		
P4	Accuracy	P2: ISO Class 2, P4: ISO Class 4, P5: ISO Class 5	222-225	
		P4Y: Special class (bore diameter and outside diameter are exclusive to NSK, all others are ISO Class 4)		

Numbering System for Double-Row Cylindrical Roller Bearings

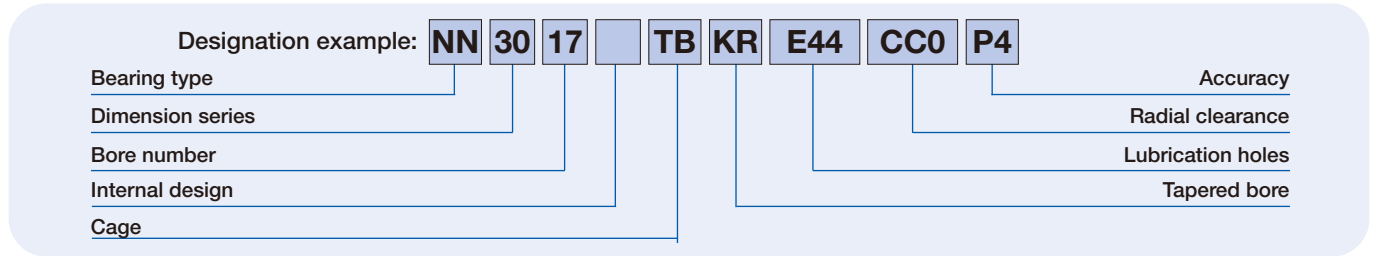

Code	Property	Description	Reference pages
NN	Bearing type	NN: Double-row CRB (inner ring rib type) NNU: Double-row CRB (outer ring rib type)	46-47, 110
30	Dimension series	30: 30 Series 39: 39 Series 49: 49 Series	46-47, 110
17	Bore number	Bearing bore = Bore number × 5 (mm)	116-127
Z	Internal design	No code: Standard type Z: Low heat generation type	116-127
TB	Cage	TB: Roller guided PPS cage No code: Rib guided brass cage	19, 24-25
		MB: Roller guided brass cage	
KR	Tapered bore	No code: Cylindrical bore KR (K): 1/12 Tapered bore	226-227
E44	Lubrication holes	No code: No lubrication holes E44: Outer ring with oil groove and lubrication holes	116-127
CC0	Radial clearance	CC1: Standard clearance for cylindrical bore (Non-interchangeable)	46-47 116-127
		CC0: Standard clearance for tapered bore (Non-interchangeable)	
		CCG: Special radial clearance	
P4	Accuracy	P2: ISO Class 2, P4: ISO Class 4, P5: ISO Class 5	222-225
		P4Y: Special class (bore diameter and outside diameter are exclusive to NSK, all others are ISO Class 4)	

2. Cylindrical Roller Bearings

Bore Diameter **30-70mm**

Single-Row Cylindrical Roller Bearings

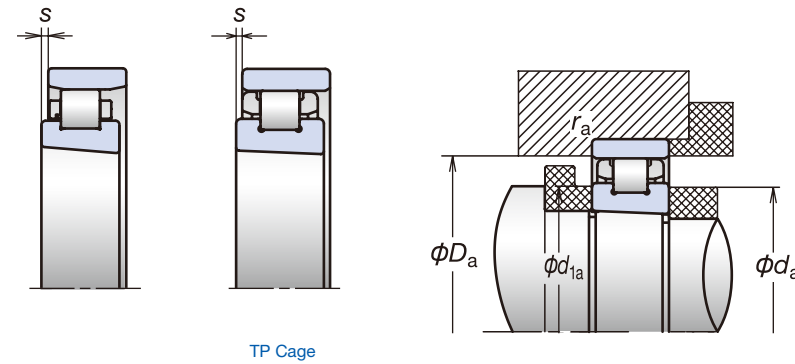
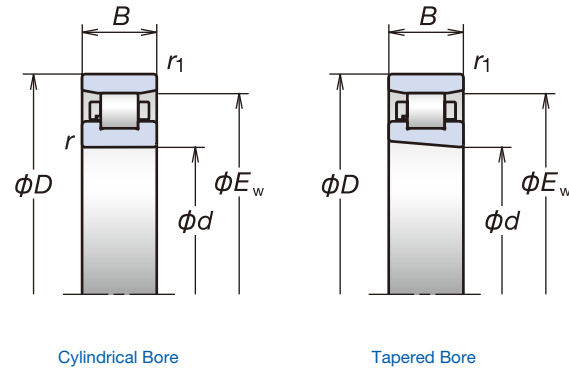

Designation ⁽¹⁾ (²)	Boundary Dimensions (mm)					Basic Load Ratings (kN)		E_w (mm) (reference)	Mass (kg) (approx.)	Limiting Speeds ⁽³⁾ (min ⁻¹)	
	d	D	B	r (min.)	r_1 (min.)	C_r (Dynamic)	C_{or} (Static)			Grease	Oil
*N1006MR1KR	30	55	13	1	0.6	19.7	19.6	48.5	0.135	19 000	31 000
*N1007MRKR	35	62	14	1	0.6	26.0	23.2	55	0.172	17 000	27 000
*N1008MRKR	40	68	15	1	0.6	31.5	29.0	61	0.213	15 000	25 000
*N1009MRKR	45	75	16	1	0.6	37.5	35.5	67.5	0.279	14 000	22 000
*N1009RSTPKR	45	75	16	1	0.6	26.9	29.4	67.5	0.243	16 000	23 000
*N1009RSTPKR	45	75	16	1	0.6	26.9	29.4	67.5	0.243	21 000	30 000
*N1009RSZTPKR	45	75	16	1	0.6	16.0	14.7	67.5	0.224	16 000	23 000
*N1009RSZTPKR	45	75	16	1	0.6	16.0	14.7	67.5	0.224	21 000	30 000
*N1010MRKR	50	80	16	1	0.6	37.0	36.0	72.5	0.286	13 000	20 000
*N1010RSTPKR	50	80	16	1	0.6	28.8	33.0	72.5	0.265	15 000	21 000
*N1010RSTPKR	50	80	16	1	0.6	28.8	33.0	72.5	0.265	20 000	27 000
*N1010RSZTPKR	50	80	16	1	0.6	17.1	16.5	72.5	0.244	15 000	21 000
*N1010RSZTPKR	50	80	16	1	0.6	17.1	16.5	72.5	0.244	20 000	27 000
*N1011BMR1KR	55	90	18	1.1	1	43.5	44.0	81	0.425	12 000	18 000
*N1011RSTPKR	55	90	18	1.1	1	35.0	39.5	81	0.383	13 000	19 000
*N1011RSTPKR	55	90	18	1.1	1	35.0	39.5	81	0.383	18 000	25 000
*N1011RSZTPKR	55	90	18	1.1	1	20.7	19.7	81	0.355	13 000	19 000
*N1011RSZTPKR	55	90	18	1.1	1	20.7	19.7	81	0.355	18 000	25 000
*N1012BMR1KR	60	95	18	1.1	1	46.0	48.5	86.1	0.454	11 000	17 000
*N1012RSTPKR	60	95	18	1.1	1	37.5	44.0	86.1	0.411	12 000	18 000
*N1012RSTPKR	60	95	18	1.1	1	37.5	44.0	86.1	0.411	17 000	23 000
*N1012RSZTPKR	60	95	18	1.1	1	22.2	22.1	86.1	0.380	12 000	18 000
*N1012RSZTPKR	60	95	18	1.1	1	22.2	22.1	86.1	0.380	17 000	23 000
*N1013BMR1KR	65	100	18	1.1	1	47.0	51.0	91	0.483	10 000	16 000
*N1013RSTPKR	65	100	18	1.1	1	39.5	49.0	91	0.440	11 000	17 000
*N1013RSTPKR	65	100	18	1.1	1	39.5	49.0	91	0.440	16 000	22 000
*N1013RSZTPKR	65	100	18	1.1	1	23.6	24.5	91	0.406	11 000	17 000
*N1013RSZTPKR	65	100	18	1.1	1	23.6	24.5	91	0.406	16 000	22 000
*N1014BMR1KR	70	110	20	1.1	1	57.5	63.0	100	0.668	9 000	15 000
*N1014RSTPKR	70	110	20	1.1	1	46.5	57.0	100	0.607	10 000	16 000
*N1014RSTPKR	70	110	20	1.1	1	46.5	57.0	100	0.607	15 000	20 000
*N1014RSZTPKR	70	110	20	1.1	1	27.8	28.5	100	0.563	10 000	16 000
*N1014RSZTPKR	70	110	20	1.1	1	27.8	28.5	100	0.563	15 000	20 000

⁽⁴⁾ Axial Displacement (mm)	Abutment and Fillet Dimensions (mm)					Clearances in Bearings with Tapered Bores (μm)						Clearances in Bearings with Cylindrical Bores (μm)	
	d_a (min.)	d_{1a} (min.)	D_a		r_a (max.)	CC9 ⁽⁵⁾		CC0		CC1		CC1	
			(max.)	(min.)		min.	max.	min.	max.	min.	max.		
1.1	35	36	51	49	0.5	5	10	8	15	10	25	5	15
1.5	40	41	58	56	0.5	5	12	8	15	12	25	5	15
1.7	45	46	64	62	0.6	5	12	8	15	12	25	5	15
2.0	50	51	71	68	0.6	5	15	10	20	15	30	5	18
1.1	50	51	71	68	0.6	5	15	10	20	15	30	5	18
1.1	50	51	71	68	0.6	5	15	10	20	15	30	5	18
1.1	50	51	71	68	0.6	5	15	10	20	15	30	5	18
1.1	50	51	71	68	0.6	5	15	10	20	15	30	5	18
2.0	55	56	76	73	0.6	5	15	10	20	15	30	5	18
1.1	55	56	76	73	0.6	5	15	10	20	15	30	5	18
1.1	55	56	76	73	0.6	5	15	10	20	15	30	5	18
1.1	55	56	76	73	0.6	5	15	10	20	15	30	5	18
1.1	55	56	76	73	0.6	5	15	10	20	15	30	5	18
2.7	61.5	63	85	82	1	5	15	10	20	15	35	5	20
1.1	61.5	63	85	82	1	5	15	10	20	15	35	5	20
1.1	61.5	63	85	82	1	5	15	10	20	15	35	5	20
1.1	61.5	63	85	82	1	5	15	10	20	15	35	5	20
1.1	61.5	63	85	82	1	5	15	10	20	15	35	5	20
2.7	66.5	68	90	87	1	5	15	10	20	15	35	5	20
1.1	66.5	68	90	87	1	5	15	10	20	15	35	5	20
1.1	66.5	68	90	87	1	5	15	10	20	15	35	5	20
1.1	66.5	68	90	87	1	5	15	10	20	15	35	5	20
1.1	66.5	68	90	87	1	5	15	10	20	15	35	5	20
2.7	71.5	73	95	92	1	5	15	10	20	15	35	5	20
1.1	71.5	73	95	92	1	5	15	10	20	15	35	5	20
1.1	71.5	73	95	92	1	5	15	10	20	15	35	5	20
1.1	71.5	73	95	92	1	5	15	10	20	15	35	5	20
1.1	71.5	73	95	92	1	5	15	10	20	15	35	5	20
3.2	76.5	78	105	101	1	10	20	15	30	20	40	10	25
1.3	76.5	78	105	101	1	10	20	15	30	20	40	10	25
1.3	76.5	78	105	101	1	10	20	15	30	20	40	10	25
1.3	76.5	78	105	101	1	10	20	15	30	20	40	10	25
1.3	76.5	78	105	101	1	10	20	15	30	20	40	10	25

(¹) Designations listed here are suffixed with "K" or "KR" to indicate tapered bores (1:12). For cylindrical bores, omit this code.
 (²) GN gauges are available for bearing designations with asterisk (*). For details, refer to Page 180.
 (³) For details on limiting speeds, refer to Page 216.
 (⁴) Axial displacement refers the allowable amount that the outer and inner rings may move from their normal positions in the axial direction.
 (⁵) Clearance CC9 is applicable to cylindrical roller bearings with tapered bores in ISO Tolerance Classes 5 and 4.

For additional information:
 ● Dynamic Equivalent Load ······P191
 ● Static Equivalent Load ······P198
 ● Nozzle Position ······P240
 ● Recommended Grease Quantities ······P257

2. Cylindrical Roller Bearings

Bore Diameter **75-400 mm**

Single-Row Cylindrical Roller Bearings

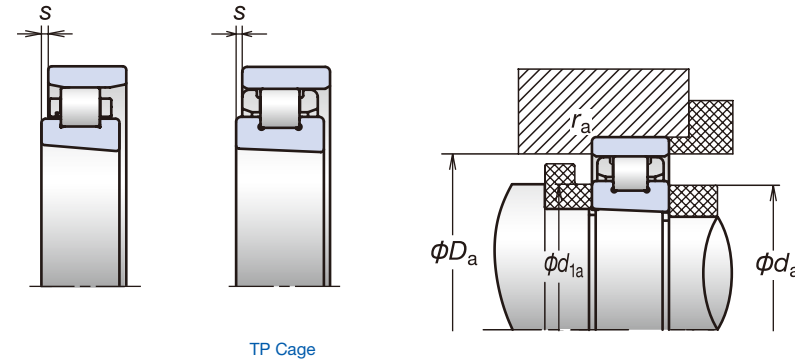
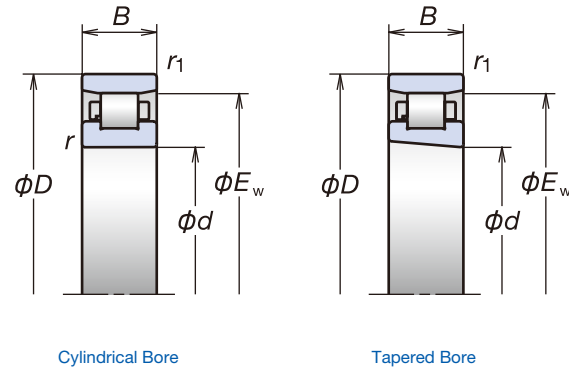

Designation ⁽¹⁾ (²)	Boundary Dimensions (mm)					Basic Load Ratings (kN)		E_w (mm) (reference)	Mass (kg) (approx.)	Limiting Speeds ⁽³⁾ (min ⁻¹)	
	d	D	B	r (min.)	r_1 (min.)	C_r (Dynamic)	C_{or} (Static)			Grease	Oil
*N1015MRKR	75	115	20	1.1	1	69.0	74.5	105	0.700	8 500	13 700
*N1015RSTPKR	75	115	20	1.1	1	49.5	63.0	105	0.645	9 900	15 000
*N1015RXTPKR	75	115	20	1.1	1	49.5	63.0	105	0.645	14 000	19 000
*N1015RSZTPKR	75	115	20	1.1	1	29.6	31.5	105	0.596	9 900	15 000
*N1015RXZTPKR	75	115	20	1.1	1	29.6	31.5	105	0.596	14 000	19 000
*N1016BMR1KR	80	125	22	1.1	1	73.0	82.0	113	0.957	7 900	12 700
*N1016RSTPKR	80	125	22	1.1	1	61.5	78.5	113	0.872	9 200	14 000
*N1016RXTPKR	80	125	22	1.1	1	61.5	78.5	113	0.872	13 000	17 000
*N1016RSZTPKR	80	125	22	1.1	1	36.5	39.5	113	0.805	9 200	14 000
*N1016RXZTPKR	80	125	22	1.1	1	36.5	39.5	113	0.805	13 000	17 000
*N1017BMR1KR	85	130	22	1.1	1	75.0	86.0	118	1.067	7 500	10 300
*N1017RSTPKR	85	130	22	1.1	1	65.0	86.0	118	0.933	8 800	13 000
*N1017RXTPKR	85	130	22	1.1	1	65.0	86.0	118	0.933	12 000	17 000
*N1017RSZTPKR	85	130	22	1.1	1	38.5	43.0	118	0.859	8 800	13 000
*N1017RXZTPKR	85	130	22	1.1	1	38.5	43.0	118	0.859	12 000	17 000
*N1018MRKR	90	140	24	1.5	1.1	101	114	127	1.27	7 000	9 600
*N1019BMR1KR	95	145	24	1.5	1.1	95.0	114	132	1.37	6 700	9 200
*N1020MRKR	100	150	24	1.5	1.1	107	126	137	1.46	6 400	8 800
*N1021BMR1KR	105	160	26	2	1.1	129	155	146	1.79	6 100	8 300
*N1022BMR1KR	110	170	28	2	1.1	144	173	155	2.22	5 800	7 900
*N1024MRKR	120	180	28	2	1.1	159	191	165	2.34	5 400	7 300
*N1026MRKR	130	200	33	2	1.1	198	238	182	3.55	4 900	6 700
*N1028BMR1KR	140	210	33	2	1.1	189	240	192	3.78	4 600	6 300
*N1030BMRKR	150	225	35	2.1	1.5	233	294	206	4.56	4 300	5 100
*N1032BMRKR	160	240	38	2.1	1.5	330	340	219	5.59	4 000	4 800
N1034MRKR	170	260	42	2.1	2.1	330	415	237	7.85	3 600	4 400
N1036MRKR	180	280	46	2.1	2.1	405	510	255	9.76	3 400	4 100
N1038KR	190	290	46	2.1	2.1	415	535	265	10.4	3 200	4 000
N1040MRKR	200	310	51	2.1	2.1	450	580	281	13.5	3 000	3 700
N1044MRKR	220	340	56	3	3	575	750	310	17.4	2 500	3 000
N1048KR	240	360	56	3	3	605	820	330	18.6	2 300	2 800
N1052KR	260	400	65	4	4	645	1 000	364	27.6	2 100	2 600
N1060KR	300	460	74	4	4	885	1 400	420	42.2	1 800	2 200
N1064KR	320	480	74	4	4	905	1 470	440	43.8	1 800	2 100
N1068KR	340	520	82	5	5	1 080	1 740	475	59.8	1 600	2 000
N1072KR	360	540	82	5	5	1 110	1 830	495	61.6	1 600	1 900
N1080KR	400	600	90	5	5	1 360	2 280	550	84.1	1 400	1 700

⁽⁴⁾ Axial Displacement (mm)	Abutment and Fillet Dimensions (mm)					Clearances in Bearings with Tapered Bores (μm)						Clearances in Bearings with Cylindrical Bores (μm)	
	d_a (min.)	d_{1a} (min.)	D_a		r_a (max.)	CC9 ⁽⁵⁾		CC0		CC1		CC1	
			(max.)	(min.)		min.	max.	min.	max.	min.	max.		
2.7	81.5	83	110	106	1	10	20	15	30	20	40	10	25
1.3	81.5	83	110	106	1	10	20	15	30	20	40	10	25
1.3	81.5	83	110	106	1	10	20	15	30	20	40	10	25
1.3	81.5	83	110	106	1	10	20	15	30	20	40	10	25
1.3	81.5	83	110	106	1	10	20	15	30	20	40	10	25
2.2	86.5	88	120	115	1	10	20	15	30	20	40	10	25
1.8	86.5	88	120	115	1	10	20	15	30	20	40	10	25
1.8	86.5	88	120	115	1	10	20	15	30	20	40	10	25
1.8	86.5	88	120	115	1	10	20	15	30	20	40	10	25
1.8	86.5	88	120	115	1	10	20	15	30	20	40	10	25
3.7	91.5	93	125	120	1	10	25	20	35	25	45	10	30
1.8	91.5	93	125	120	1	10	25	20	35	25	45	10	30
1.8	91.5	93	125	120	1	10	25	20	35	25	45	10	30
1.8	91.5	93	125	120	1	10	25	20	35	25	45	10	30
1.8	91.5	93	125	120	1	10	25	20	35	25	45	10	30
1.1	98	100	133.5	129	1	10	25	20	35	25	45	10	30
1.6	103	105	138.5	134	1	10	25	20	35	25	45	10	30
1.1	108	110	143.5	139	1	10	25	20	35	25	45	10	30
1.6	114	116	153.5	148	1	10	25	20	35	25	50	10	30
2.1	119	121	163.5	157	1	10	25	20	35	25	50	10	30
1.8	129	131	173.5	167	1	10	25	20	35	25	50	10	30
3.3	139	142	193.5	184	1	15	30	25	40	30	60	10	35
3.8	149	152	203.5	194	1	15	30	25	40	30	60	10	35
3.8	161	164	217	208	1.5	15	35	30	50	35	65	10	35
1.9	171	174	232	221	1.5	15	35	30	50	35	65	10	35
2.9	181	185	249	239	2	15	35	30	50	35	75	10	40
1.5	191	195	269	258	2	15	35	30	50	35	75	10	40
1.5	201	205	279	268	2	20	40	30	50	40	80	15	45
3.0	211	215	299	284	2	20	40	30	50	40	80	15	45
3.5	233	238	327	313	2.5	20	45	35	60	45	90	15	50
3.5	253	258	347	333	2.5	25	50	40	65	50	100	15	50
3.8	276	281	384	367	3	25	55	40	70	55	110	20	55
5.3	316	322	444	424	3	30	60	45	75	60	120	20	60
5.3	336	342	464	444	3	30	65	45	80	65	135	20	65
4.3	360	367	500	479	4	30	65	45	80	65	135	20	65
4.3	380	387	520	499	4	35	75	50	90	75	150	25	75
5.8	420	428	580	554.5	4	35	75	50	90	75	150	25	75

(¹) Designations listed here are suffixed with "K" or "KR" to indicate tapered bores (1:12). For cylindrical bores, omit this code.
 (²) GN gauges are available for bearing designations with asterisk (*). For details, refer to Page 180.
 (³) For details on limiting speeds, refer to Page 216.
 (⁴) Axial displacement refers the allowable amount that the outer and inner rings may move from their normal positions in the axial direction.
 (⁵) Clearance CC9 is applicable to cylindrical roller bearings with tapered bores in ISO Tolerance Classes 5 and 4.

For additional information:
 ● Dynamic Equivalent Load ······P191
 ● Static Equivalent Load ······P198
 ● Nozzle Position ······P240
 ● Recommended Grease Quantities ······P257

2. Cylindrical Roller Bearings

Bore Diameter **25-65mm**

Double-Row Cylindrical Roller Bearings

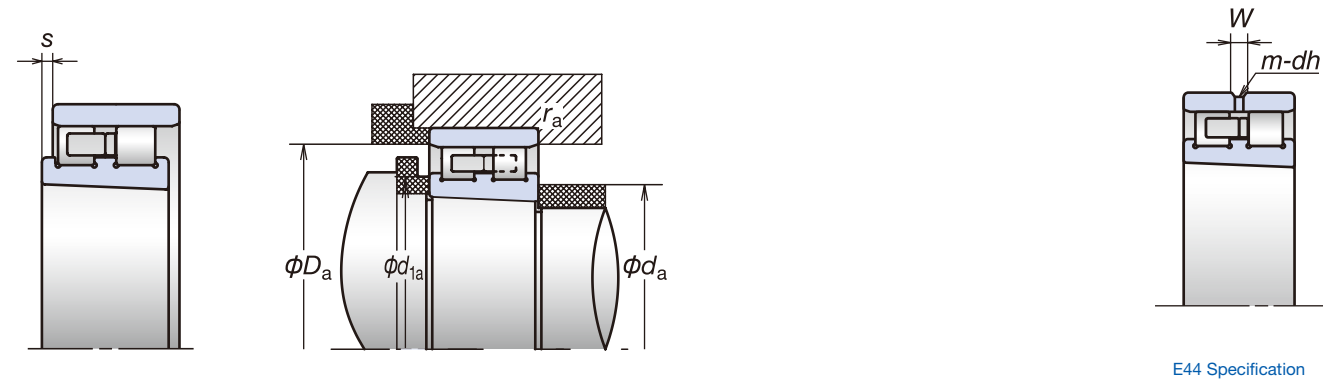
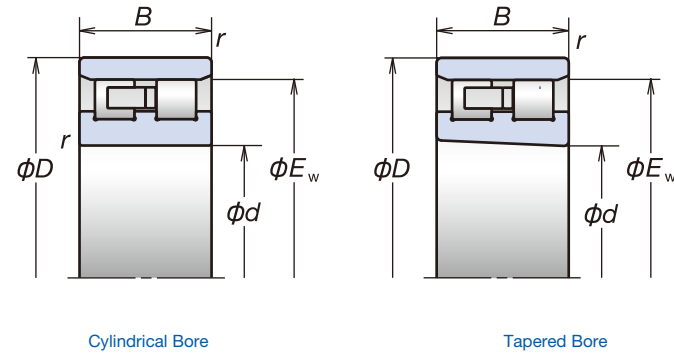

Designation ⁽¹⁾ (²)	Boundary Dimensions (mm)				Basic Load Ratings (kN)		E_w (mm) (reference)	Mass (kg) (approx.)	Limiting Speeds ⁽³⁾ (min ⁻¹)	
	d	D	B	r (min.)	C_r (Dynamic)	C_{or} (Static)			Grease	Oil
* NN3005MBKR	25	47	16	0.6	25.8	30.0	41.3	0.121	20 900	25 000
* NN3006MBKR	30	55	19	1	31.0	37.0	48.5	0.186	17 700	21 200
* NN3006TBKR	30	55	19	1	31.0	37.0	48.5	0.171	20 000	23 600
* NN3006ZTBKR	30	55	19	1	18.3	18.6	48.5	0.152	21 000	27 900
* NN3007MBKR	35	62	20	1	39.5	50.0	55	0.297	15 500	18 600
* NN3007TBKR	35	62	20	1	39.5	50.0	55	0.227	17 600	20 700
* NN3007ZTBKR	35	62	20	1	23.3	25.0	55	0.198	18 400	24 500
* NN3008MBKR	40	68	21	1	50.0	55.5	61	0.356	13 900	16 700
* NN3008TBKR	40	68	21	1	50.0	55.5	61	0.269	15 800	18 600
* NN3008ZTBKR	40	68	21	1	29.6	27.7	61	0.234	16 600	22 000
* NN3009MBKR	45	75	23	1	59.5	68.5	67.5	0.471	12 500	15 000
* NN3009TBKR	45	75	23	1	57.5	65.5	67.5	0.348	14 200	16 700
* NN3009ZTBKR	45	75	23	1	34.0	32.5	67.5	0.302	14 900	19 800
* NN3010MBKR	50	80	23	1	61.0	72.5	72.5	0.502	11 600	13 900
* NN3010TBKR	50	80	23	1	61.0	72.5	72.5	0.378	13 100	15 400
* NN3010ZTBKR	50	80	23	1	36.5	36.5	72.5	0.328	13 800	18 300
* NN3011MBKR	55	90	26	1.1	79.5	96.5	81	0.748	10 400	12 500
* NN3011TBKR	55	90	26	1.1	79.5	96.5	81	0.562	11 800	13 800
* NN3011ZTBKR	55	90	26	1.1	47.5	48.5	81	0.488	12 400	16 400
* NN3012MBKR	60	95	26	1.1	84.5	106	86.1	0.804	9 700	11 700
* NN3012TBKR	60	95	26	1.1	84.5	106	86.1	0.602	11 000	13 000
* NN3012ZTBKR	60	95	26	1.1	50.0	53.0	86.1	0.522	11 600	15 400
* NN3013MBKR	65	100	26	1.1	88.5	116	91	0.862	9 100	11 000
* NN3013TBKR	65	100	26	1.1	88.5	116	91	0.644	10 400	12 200
* NN3013ZTBKR	65	100	26	1.1	52.5	58.0	91	0.557	10 900	14 500

⁽⁴⁾ Axial Displacement (mm)	Abutment and Fillet Dimensions (mm)					Clearances in Bearings with Tapered Bores (μm)						Clearances in Bearings with Cylindrical Bores (μm)			E44 Specification Lubrication Holes Dimensions (mm)		
	s	d_a (min.)	d_{1a} (min.)	D_a (max.)	r_a (min.)	CC9 ⁽⁵⁾		CC0		CC1		CC1		Hole Dia. dh	Oil Groove Width W	Number of Holes m	
0.8	29	29	43	42	0.6	5	10	8	15	10	25	5	15	2	3.5	4	
1.3	35	36	50	50	1	5	10	8	15	10	25	5	15	2	3.5	4	
1.3	35	36	50	50	1	5	10	8	15	10	25	5	15	2	3.5	4	
1.3	35	36	50	50	1	5	10	8	15	10	25	5	15	2	3.5	4	
1.3	40	41	57	56	1	5	12	8	15	12	25	5	15	2	3.5	4	
1.3	40	41	57	56	1	5	12	8	15	12	25	5	15	2	3.5	4	
1.3	40	41	57	56	1	5	12	8	15	12	25	5	15	2	3.5	4	
1.4	45	46	63	62	1	5	12	8	15	12	25	5	15	2	3.5	4	
1.4	45	46	63	62	1	5	12	8	15	12	25	5	15	2	3.5	4	
1.4	45	46	63	62	1	5	12	8	15	12	25	5	15	2	3.5	4	
1.2	50	51	70	69	1	5	15	10	20	15	30	5	18	2	3.5	4	
1.2	50	51	70	69	1	5	15	10	20	15	30	5	18	2	3.5	4	
1.2	50	51	70	69	1	5	15	10	20	15	30	5	18	2	3.5	4	
1.2	55	56	75	74	1	5	15	10	20	15	30	5	18	2	3.5	4	
1.2	55	56	75	74	1	5	15	10	20	15	30	5	18	2	3.5	4	
1.2	55	56	75	74	1	5	15	10	20	15	30	5	18	2	3.5	4	
1.4	61.5	62	83.5	83	1	5	15	10	20	15	35	5	20	2	3.5	4	
1.4	61.5	62	83.5	83	1	5	15	10	20	15	35	5	20	2	3.5	4	
1.4	61.5	62	83.5	83	1	5	15	10	20	15	35	5	20	2	3.5	4	
1.4	66.5	67	88.5	88	1	5	15	10	20	15	35	5	20	2	3.5	4	
1.4	66.5	67	88.5	88	1	5	15	10	20	15	35	5	20	2	3.5	4	
1.4	66.5	67	88.5	88	1	5	15	10	20	15	35	5	20	2	3.5	4	
1.4	71.5	72	93.5	93	1	5	15	10	20	15	35	5	20	2	3.5	4	
1.4	71.5	72	93.5	93	1	5	15	10	20	15	35	5	20	2	3.5	4	
1.4	71.5	72	93.5	93	1	5	15	10	20	15	35	5	20	2	3.5	4	

(¹) Designations listed here are suffixed with "K" or "KR" to indicate tapered bores (1:12). For cylindrical bores, omit this code.
(²) GN gauges are available for bearing designations with asterisk (*). For details, refer to Page 180.
(³) For details on limiting speeds, refer to Page 216.
(⁴) Axial displacement refers the allowable amount that the outer and inner rings may move from their normal positions in the axial direction.
(⁵) Clearance CC9 is applicable to cylindrical roller bearings with tapered bores in ISO Tolerance Classes 5 and 4.

For additional information:
● Dynamic Equivalent Load ······P191
● Static Equivalent Load ······P198
● Nozzle Position ······P240
● Recommended Grease Quantities ···P257

Cylindrical Roller Bearings Double Row

2. Cylindrical Roller Bearings

Bore Diameter **70-105 mm**

Double-Row Cylindrical Roller Bearings

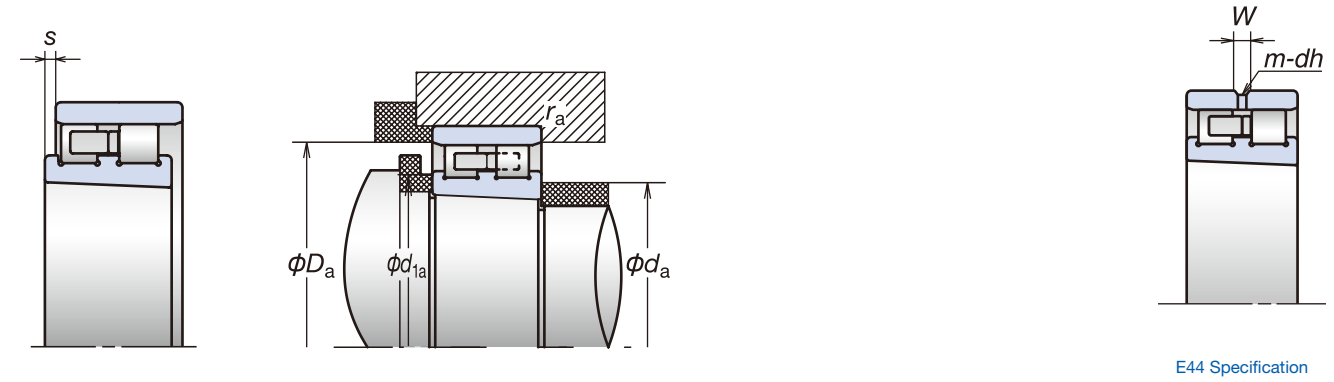
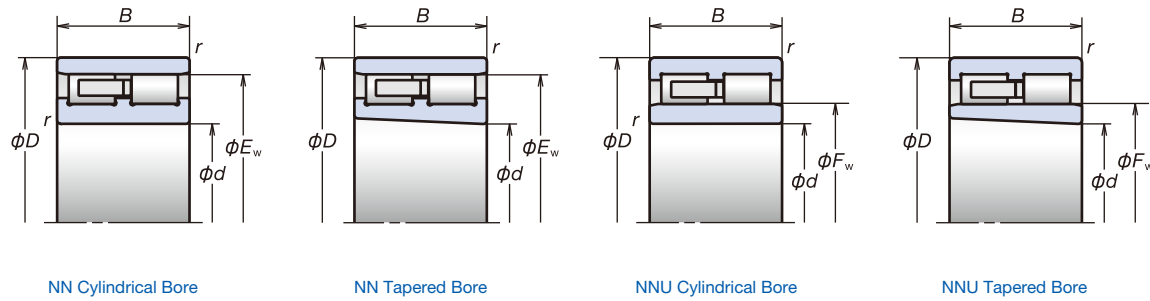

Designation ⁽¹⁾ (²)	Boundary Dimensions (mm)				Basic Load Ratings (kN)		E_w (F_w in case of NNU type) (mm) (reference)	Mass (kg) (approx.)	Limiting Speeds ⁽³⁾ (min ⁻¹)	
	d	D	B	r (min.)	C_r (Dynamic)	C_{or} (Static)			Grease	Oil
*NN3014MBKR	70	110	30	1.1	112	148	100	1.23	8 000	10 000
*NN3014TBKR	70	110	30	1.1	112	148	100	0.925	9 500	11 200
*NN3014ZTBKR	70	110	30	1.1	66.5	74.0	100	0.809	9 900	13 200
*NN3015MBKR	75	115	30	1.1	111	149	105	1.28	7 900	9 500
*NN3015TBKR	75	115	30	1.1	111	149	105	0.964	9 000	10 600
*NN3015ZTBKR	75	115	30	1.1	66.0	74.5	105	0.848	9 400	12 500
*NN3016MBKR	80	125	34	1.1	137	186	113	1.77	7 400	8 800
*NN3016TBKR	80	125	34	1.1	137	186	113	1.35	8 300	9 800
*NN3016ZTBKR	80	125	34	1.1	81.5	93.0	113	1.19	8 800	11 700
*NN3017MBKR	85	130	34	1.1	144	201	118	1.87	7 000	8 400
*NN3017TBKR	85	130	34	1.1	144	201	118	1.42	8 000	9 400
*NN3017ZTBKR	85	130	34	1.1	85.5	101	118	1.25	8 400	11 100
*NN3018MBKR	90	140	37	1.5	164	228	127	2.38	6 600	7 900
*NN3018TBKR	90	140	37	1.5	164	228	127	1.82	7 400	8 700
*NN3018ZTBKR	90	140	37	1.5	97.5	114	127	1.61	7 800	10 300
*NN3019MBKR	95	145	37	1.5	173	246	132	2.51	6 300	7 500
*NN3019TBKR	95	145	37	1.5	173	246	132	1.91	7 100	8 400
*NN3019ZTBKR	95	145	37	1.5	103	123	132	1.68	7 500	9 900
NN3920MBKR	100	140	30	1.1	122	182	130	1.32	6 300	7 500
NN4920MBKR	100	140	40	1.1	178	295	130	1.76	6 300	7 500
NNU4920MBKR	100	140	40	1.1	178	295	112	1.75	6 300	7 500
*NN3020MBKR	100	150	37	1.5	180	265	137	2.63	6 000	7 200
*NN3020TBKR	100	150	37	1.5	180	265	137	2.00	6 800	8 000
*NN3020ZTBKR	100	150	37	1.5	107	133	137	1.76	7 200	9 500
NN4921MBKR	105	145	40	1.1	185	315	135	1.91	6 000	7 200
NNU4921MBKR	105	145	40	1.1	185	315	117	1.83	6 000	7 200
*NN3021MBKR	105	160	41	2	228	320	146	3.40	5 700	6 800
*NN3021TBKR	105	160	41	2	228	320	146	2.52	6 500	7 600
*NN3021ZTBKR	105	160	41	2	135	161	146	2.17	6 800	9 000

⁽⁴⁾ Axial Displacement (mm)	Abutment and Fillet Dimensions (mm)					Clearances in Bearings with Tapered Bores (μm)						Clearances in Bearings with Cylindrical Bores (μm)		E44 Specification Lubrication Holes Dimensions (mm)			
	s	d_a (min.)	d_{1a} (min.)	D_a		r_a (max.)	CC9 ⁽⁵⁾		CC0		CC1		CC1		Hole Dia. dh	Oil Groove Width W	Number of Holes m
				(max.)	(min.)		min.	max.	min.	max.	min.	max.					
1.2	76.5	77	103.5	102	1	10	20	15	30	20	40	10	25	2	3.5	4	
1.2	76.5	77	103.5	102	1	10	20	15	30	20	40	10	25	2	3.5	4	
1.2	76.5	77	103.5	102	1	10	20	15	30	20	40	10	25	2	3.5	4	
1.2	81.5	82	108.5	107	1	10	20	15	30	20	40	10	25	2	3.5	4	
1.2	81.5	82	108.5	107	1	10	20	15	30	20	40	10	25	2	3.5	4	
1.2	81.5	82	108.5	107	1	10	20	15	30	20	40	10	25	2	3.5	4	
1.7	86.5	87	118.5	115	1	10	20	15	30	20	40	10	25	2.5	5	4	
1.7	86.5	87	118.5	115	1	10	20	15	30	20	40	10	25	2.5	5	4	
1.7	86.5	87	118.5	115	1	10	20	15	30	20	40	10	25	2.5	5	4	
2.2	91.5	92	123.5	120	1	10	25	20	35	25	45	10	30	2.5	5	4	
2.2	91.5	92	123.5	120	1	10	25	20	35	25	45	10	30	2.5	5	4	
2.2	91.5	92	123.5	120	1	10	25	20	35	25	45	10	30	2.5	5	4	
1.4	98	99	132	129	1.5	10	25	20	35	25	45	10	30	2.5	5	4	
1.4	98	99	132	129	1.5	10	25	20	35	25	45	10	30	2.5	5	4	
1.4	98	99	132	129	1.5	10	25	20	35	25	45	10	30	2.5	5	4	
1.4	103	104	137	134	1.5	10	25	20	35	25	45	10	30	2.5	5	4	
1.4	103	104	137	134	1.5	10	25	20	35	25	45	10	30	2.5	5	4	
1.4	103	104	137	134	1.5	10	25	20	35	25	45	10	30	2.5	5	4	
1.2	106.5	108	133.5	132	1	10	25	20	35	25	45	10	30	2	3.5	4	
1.2	106.5	108	133.5	132	1	10	25	20	35	25	45	10	30	2.5	5	4	
1.2	106.5	108	133.5	—	1	10	25	20	35	25	45	10	30	2.5	5	4	
1.4	108	109	142	139	1.5	10	25	20	35	25	45	10	30	2.5	5	4	
1.4	108	109	142	139	1.5	10	25	20	35	25	45	10	30	2.5	5	4	
1.4	108	109	142	139	1.5	10	25	20	35	25	45	10	30	2.5	5	4	
1.2	111.5	113	138.5	137	1	10	25	20	35	25	50	10	30	2.5	5	4	
1.2	111.5	113	138.5	—	1	10	25	20	35	25	50	10	30	2.5	5	4	
2.7	114	115	151	148	2	10	25	20	35	25	50	10	30	3	6	4	
2.7	114	115	151	148	2	10	25	20	35	25	50	10	30	3	6	4	
2.7	114	115	151	148	2	10	25	20	35	25	50	10	30	3	6	4	

(¹) Designations listed here are suffixed with "K" or "KR" to indicate tapered bores (1:12). For cylindrical bores, omit this code.
(²) GN gauges are available for bearing designations with asterisk (*). For details, refer to Page 180.
(³) For details on limiting speeds, refer to Page 216.
(⁴) Axial displacement refers the allowable amount that the outer and inner rings may move from their normal positions in the axial direction.
(⁵) Clearance CC9 is applicable to cylindrical roller bearings with tapered bores in ISO Tolerance Classes 5 and 4.

For additional information:
● Dynamic Equivalent Load ······P191
● Static Equivalent Load ······P198
● Nozzle Position ······P240
● Recommended Grease Quantities ······P257

Cylindrical Roller Bearings Double Row

2. Cylindrical Roller Bearings

Bore Diameter **110-160mm**

Double-Row Cylindrical Roller Bearings

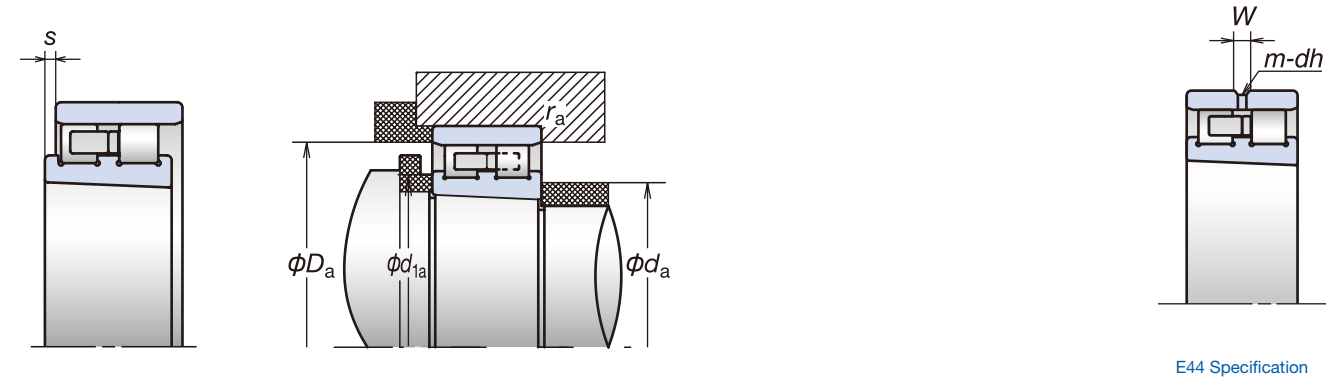
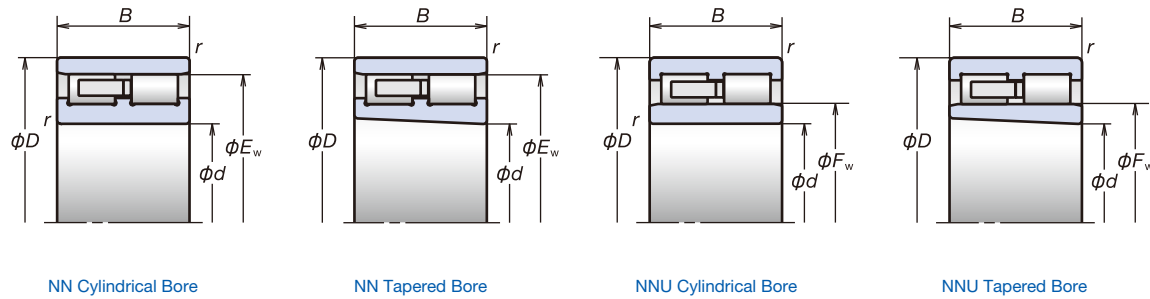

Designation ⁽¹⁾ (²)	Boundary Dimensions (mm)				Basic Load Ratings (kN)		E_w (F_w in case of NNU type) (mm) (reference)	Mass (kg) (approx.)	Limiting Speeds ⁽³⁾ (min ⁻¹)	
	d	D	B	r (min.)	C_r (Dynamic)	C_{or} (Static)			Grease	Oil
NN3922MBKR	110	150	30	1.1	131	207	140	1.44	5 800	7 000
NN4922MBKR	110	150	40	1.1	192	335	140	1.92	5 800	7 000
NNU4922MBKR	110	150	40	1.1	192	335	122	1.90	5 800	7 000
*NN3022MBKR	110	170	45	2	263	375	155	4.35	5 400	6 500
*NN3022TBKR	110	170	45	2	263	375	155	3.21	6 100	7 200
*NN3022ZTBKR	110	170	45	2	156	188	155	2.78	6 400	8 500
NN3924MBKR	120	165	34	1.1	158	251	153.5	2.02	5 300	6 400
NN4924MBKR	120	165	45	1.1	211	360	153.5	2.62	5 300	6 400
NNU4924MBKR	120	165	45	1.1	211	360	133.5	2.59	5 300	6 400
*NN3024MBKR	120	180	46	2	275	405	165	4.72	5 000	6 000
*NN3024TBKR	120	180	46	2	275	405	165	3.50	5 700	6 700
*NN3024ZTBKR	120	180	46	2	164	203	165	3.03	6 000	7 900
NN3926MBKR	130	180	37	1.5	199	325	167	2.64	4 900	5 900
NN4926MBKR	130	180	50	1.5	315	545	168	3.51	4 900	5 900
NNU4926MBKR	130	180	50	1.5	315	545	144	3.48	4 900	5 900
*NN3026MBKR	130	200	52	2	325	475	182	5.53	4 600	5 500
*NN3026TBKR	130	200	52	2	325	475	182	5.10	5 200	6 100
*NN3026ZTBKR	130	200	52	2	195	238	182	4.46	5 500	7 200
NN3928MBKR	140	190	37	1.5	232	375	178	2.79	4 600	5 500
NN4928MBKR	140	190	50	1.5	325	585	178	3.73	4 600	5 500
NNU4928MBKR	140	190	50	1.5	325	585	154	3.70	4 600	5 500
*NN3028MBKR	140	210	53	2	345	515	192	5.95	4 300	5 200
*NN3028TBKR	140	210	53	2	345	515	192	5.51	4 900	5 700
*NN3028ZTBKR	140	210	53	2	204	258	192	4.81	5 200	6 800
NN3930MBKR	150	210	45	2	300	490	195	4.47	4 200	5 000
NN4930MBKR	150	210	60	2	405	715	195	5.79	4 200	5 000
NNU4930MBKR	150	210	60	2	405	715	167	5.85	4 200	5 000
*NN3030MBKR	150	225	56	2.1	385	585	206	7.29	4 000	4 800
*NN3030TBKR	150	225	56	2.1	385	585	206	6.70	4 500	5 300
*NN3030ZTBKR	150	225	56	2.1	229	294	206	5.87	4 800	6 300
NN3932MBKR	160	220	45	2	310	520	205	4.72	4 000	4 800
NN4932MBKR	160	220	60	2	420	760	205	6.19	4 000	4 800
NNU4932MBKR	160	220	60	2	420	760	177	6.18	4 000	4 800
*NN3032MBKR	160	240	60	2.1	430	660	219	8.83	3 800	4 500
*NN3032TBKR	160	240	60	2.1	430	660	219	8.18	4 300	5 000
*NN3032ZTBKR	160	240	60	2.1	255	330	219	7.20	4 500	6 000

⁽⁴⁾ Axial Displacement (mm)	Abutment and Fillet Dimensions (mm)					Clearances in Bearings with Tapered Bores (μm)						Clearances in Bearings with Cylindrical Bores (μm)		E44 Specification Lubrication Holes Dimensions (mm)			
	s	d_a (min.)	d_{1a} (min.)	D_a		r_a (max.)	CC9 ⁽⁵⁾		CC0		CC1		CC1		Hole Dia. dh	Oil Groove Width W	Number of Holes m
				(max.)	(min.)		min.	max.	min.	max.	min.	max.					
1.2	116.5	118	143.5	142	1	10	25	20	35	25	50	10	30	2	3.5	4	
1.2	116.5	118	143.5	142	1	10	25	20	35	25	50	10	30	2.5	5	4	
1.2	116.5	118	143.5	—	1	10	25	20	35	25	50	10	30	2.5	5	4	
1.4	119	121	161	157	2	10	25	20	35	25	50	10	30	3	6	4	
1.4	119	121	161	157	2	10	25	20	35	25	50	10	30	3	6	4	
1.4	119	121	161	157	2	10	25	20	35	25	50	10	30	3	6	4	
1.7	126.5	128	158.5	156	1	10	25	20	35	25	50	10	30	2.5	5	4	
2.7	126.5	128	158.5	156	1	10	25	20	35	25	50	10	30	3	6	4	
2.1	126.5	128	158.5	—	1	10	25	20	35	25	50	10	30	3	6	4	
1.4	129	131	171	167	2	10	25	20	35	25	50	10	30	3	6	4	
1.4	129	131	171	167	2	10	25	20	35	25	50	10	30	3	6	4	
1.4	129	131	171	167	2	10	25	20	35	25	50	10	30	3	6	4	
1.4	138	140	172	169	1.5	15	30	25	40	30	60	10	35	2.5	5	4	
1.2	138	140	172	170	1.5	15	30	25	40	30	60	10	35	3	6	4	
1.2	138	140	172	—	1.5	15	30	25	40	30	60	10	35	3	6	4	
2.4	139	141	191	185	2	15	30	25	40	30	60	10	35	4	8	4	
2.4	139	141	191	185	2	15	30	25	40	30	60	10	35	4	8	4	
2.4	139	141	191	185	2	15	30	25	40	30	60	10	35	4	8	4	
1.2	148	150	182	180	1.5	15	30	25	40	30	60	10	35	2.5	5	4	
1.7	148	150	182	180	1.5	15	30	25	40	30	60	10	35	3	6	4	
1.7	148	150	182	—	1.5	15	30	25	40	30	60	10	35	3	6	4	
1.3	149	151	201	195	2	15	30	25	40	30	60	10	35	4	8	4	
1.3	149	151	201	195	2	15	30	25	40	30	60	10	35	4	8	4	
1.3	149	151	201	195	2	15	30	25	40	30	60	10	35	4	8	4	
1.4	159	162	201	197	2	15	35	30	50	35	65	10	35	3	6	4	
1.3	159	162	201	197	2	15	35	30	50	35	65	10	35	4	8	4	
1.3	159	162	201	—	2	15	35	30	50	35	65	10	35	4	8	4	
2.4	161	162	214	209	2	15	35	30	50	35	65	10	35	4	8	4	
2.4	161	162	214	209	2	15	35	30	50	35	65	10	35	4	8	4	
2.4	161	162	214	209	2	15	35	30	50	35	65	10	35	4	8	4	
1.4	169	172	211	207	2	15	35	30	50	35	65	10	35	3	6	4	
1.3	169	172	211	207	2	15	35	30	50	35	65	10	35	4	8	4	
1.3	169	172	211	—	2	15	35	30	50	35	65	10	35	4	8	4	
2.3	171	172	229	222	2	15	35	30	50	35	65	10	35	4	8	4	
2.3	171	172	229	222	2	15	35	30	50	35	65	10	35	4	8	4	
2.3	171	172	229	222	2	15	35	30	50	35	65	10	35	4	8	4	

⁽¹⁾ Designations listed here are suffixed with "K" or "KR" to indicate tapered bores (1:12). For cylindrical bores, omit this code.
⁽²⁾ GN gauges are available for bearing designations with asterisk (*). For details, refer to Page 180.
⁽³⁾ For details on limiting speeds, refer to Page 216.
⁽⁴⁾ Axial displacement refers the allowable amount that the outer and inner rings may move from their normal positions in the axial direction.
⁽⁵⁾ Clearance CC9 is applicable to cylindrical roller bearings with tapered bores in ISO Tolerance Classes 5 and 4.

For additional information:
 ● Dynamic Equivalent Load ······P191
 ● Static Equivalent Load ······P198
 ● Nozzle Position ······P240
 ● Recommended Grease Quantities ······P257

Cylindrical Roller Bearings Double Row

2. Cylindrical Roller Bearings

Bore Diameter **170-260mm**

Double-Row Cylindrical Roller Bearings

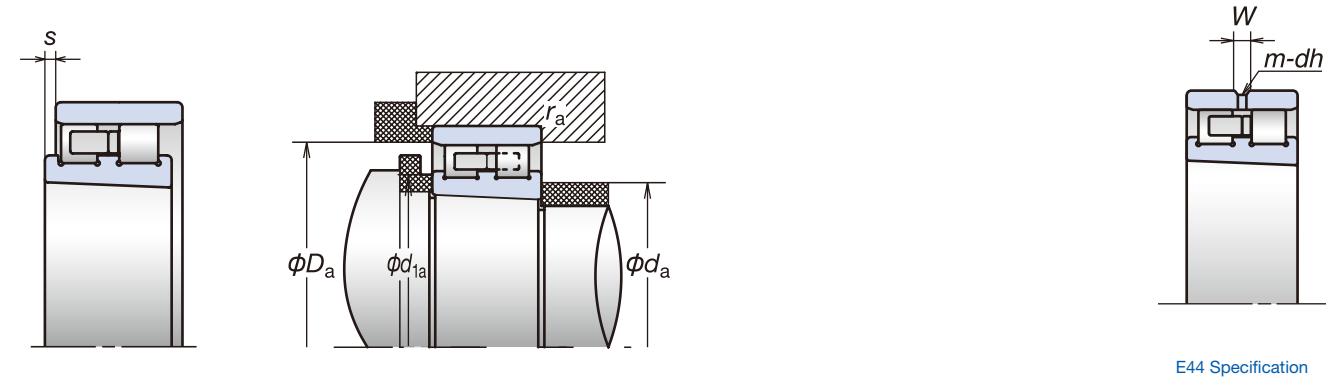
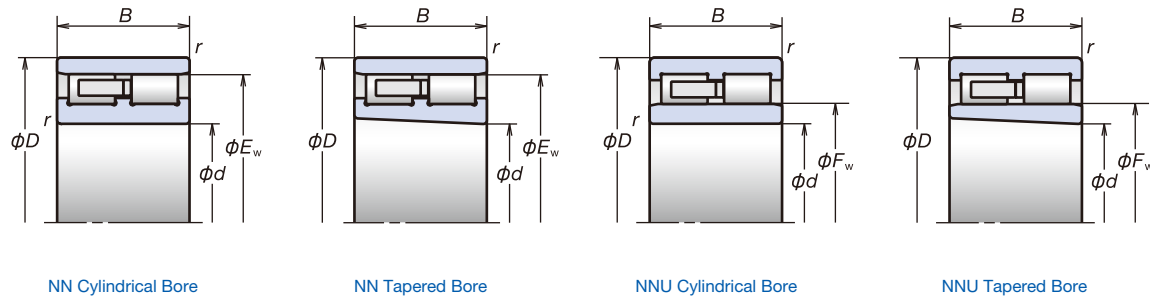

Designation (1)	Boundary Dimensions (mm)				Basic Load Ratings (kN)		E _w (F _w in case of NNU type) (mm) (reference)	Mass (kg) (approx.)	Limiting Speeds (2) (min ⁻¹)	
	d	D	B	r (min.)	C _r (Dynamic)	C _{or} (Static)			Grease	Oil
NN3934MBKR	170	230	45	2	320	550	215	5.01	3 800	4 500
NN4934MBKR	170	230	60	2	435	805	215	6.42	3 800	4 500
NNU4934MBKR	170	230	60	2	435	805	187	6.50	3 800	4 500
NN3034MBKR	170	260	67	2.1	520	805	236	12.1	3 500	4 200
NN3936MBKR	180	250	52	2	390	655	232	7.20	3 500	4 200
NN4936MBKR	180	250	69	2	550	1 020	232	9.47	3 500	4 200
NNU4936MBKR	180	250	69	2	550	1 020	200	9.55	3 500	4 200
NN3036MBKR	180	280	74	2.1	650	995	255	15.7	3 300	4 000
NN3938MBKR	190	260	52	2	395	680	243.5	7.57	3 400	4 000
NN4938MBKR	190	260	69	2	555	1 060	243.5	9.72	3 400	4 000
NNU4938MBKR	190	260	69	2	555	1 060	211.5	9.91	3 400	4 000
NN3038MBKR	190	290	75	2.1	685	1 080	265	16.7	3 200	3 800
NN3940MBKR	200	280	60	2.1	480	815	259	10.6	3 200	3 800
NN4940MBKR	200	280	80	2.1	655	1 220	259	14.0	3 200	3 800
NNU4940MBKR	200	280	80	2.1	655	1 220	223	14.0	3 200	3 800
NN3040MBKR	200	310	82	2.1	750	1 170	282	21.3	3 000	3 600
NN3944MBKR	220	300	60	2.1	505	895	279	11.5	2 500	3 100
NN4944MBKR	220	300	80	2.1	690	1 330	279	15.1	2 500	3 100
NNU4944MBKR	220	300	80	2.1	690	1 330	243	15.2	2 500	3 100
NN3044MBKR	220	340	90	3	940	1 480	310	27.7	2 400	2 900
NN3948MBKR	240	320	60	2.1	525	975	300	12.3	2 400	2 900
NN4948MBKR	240	320	80	2.1	720	1 450	300	17.8	2 400	2 900
NNU4948MBKR	240	320	80	2.1	720	1 450	263	16.2	2 400	2 900
NN3048MBKR	240	360	92	3	980	1 600	330	30.4	2 200	2 700
NN3952MBKR	260	360	75	2.1	775	1 380	335	21.4	2 100	2 600
NN4952MBKR	260	360	100	2.1	1 070	2 100	335	28.4	2 100	2 600
NNU4952MBKR	260	360	100	2.1	1 070	2 100	289	28.3	2 100	2 600
NN3052KR	260	400	104	4	1 030	1 920	364	44.7	2 000	2 500

(3) Axial Displacement (mm)	Abutment and Fillet Dimensions (mm)					Clearances in Bearings with Tapered Bores (μm)						Clearances in Bearings with Cylindrical Bores (μm)			E44 Specification Lubrication Holes Dimensions (mm)		
	s	d _a (min.)	d _{1a} (min.)	D _a (max.) (min.)		r _a (max.)	CC9 (4)		CC0		CC1		CC1		Hole Dia. dh	Oil Groove Width W	Number of Holes m
1.4	179	182	221	217	2	15	35	30	50	35	75	10	40	3	6	4	
1.3	179	182	221	217	2	15	35	30	50	35	75	10	40	4	8	4	
1.3	179	182	221	—	2	15	35	30	50	35	75	10	40	4	8	4	
2.4	181	183	249	239	2	15	35	30	50	35	75	10	40	5	9	4	
1.5	189	193	241	234	2	15	35	30	50	35	75	10	40	4	8	4	
1.3	189	193	241	234	2	15	35	30	50	35	75	10	40	5	9	4	
1.3	189	193	241	—	2	15	35	30	50	35	75	10	40	5	9	4	
2.9	191	193	269	258	2	15	35	30	50	35	75	10	40	5	9	4	
2.4	199	203	251	246	2	20	40	30	50	40	80	15	45	4	8	4	
1.3	199	203	251	246	2	20	40	30	50	40	80	15	45	5	9	4	
1.3	199	203	251	—	2	20	40	30	50	40	80	15	45	5	9	4	
1.1	201	203	279	268	2	20	40	30	50	40	80	15	45	5	9	4	
2.3	211	214	269	261	2	20	40	30	50	40	80	15	45	4	8	4	
3.3	211	214	269	261	2	20	40	30	50	40	80	15	45	5	9	4	
3.3	211	214	269	—	2	20	40	30	50	40	80	15	45	5	9	4	
2.5	211	214	299	285	2	20	40	30	50	40	80	15	45	6	12	4	
2.3	231	234	289	281	2	20	45	35	60	45	90	15	50	4	8	4	
3.3	231	234	289	281	2	20	45	35	60	45	90	15	50	5	9	4	
3.3	231	234	289	—	2	20	45	35	60	45	90	15	50	5	9	4	
3.2	233	236	327	313	2.5	20	45	35	60	45	90	15	50	6	12	4	
2.3	251	254	309	302	2	25	50	40	65	50	100	15	50	4	8	4	
1.8	251	254	309	302	2	25	50	40	65	50	100	15	50	5	9	4	
3.3	251	254	309	—	2	25	50	40	65	50	100	15	50	5	9	4	
3.5	253	256	347	334	2.5	25	50	40	65	50	100	15	50	6	12	4	
1.1	271	275	349	338	2	25	55	40	70	55	110	20	55	5	9	4	
2.4	271	275	349	338	2	25	55	40	70	55	110	20	55	6	12	4	
2.4	271	275	349	—	2	25	55	40	70	55	110	20	55	6	12	4	
3.8	276	278	384	368	3	25	55	40	70	55	110	20	55	6	12	4	

(1) Designations listed here are suffixed with "K" or "KR" to indicate tapered bores (1:12). For cylindrical bores, omit this code.
 (2) For details on limiting speeds, refer to Page 216.
 (3) Axial displacement refers the allowable amount that the outer and inner rings may move from their normal positions in the axial direction.
 (4) Clearance CC9 is applicable to cylindrical roller bearings with tapered bores in ISO Tolerance Classes 5 and 4.

For additional information:
 ● Dynamic Equivalent Load ······ P191
 ● Static Equivalent Load ······ P198
 ● Nozzle Position ······ P240
 ● Recommended Grease Quantities · P257

Cylindrical Roller Bearings Double Row

2. Cylindrical Roller Bearings

Bore Diameter **280-420mm**

Double-Row Cylindrical Roller Bearings

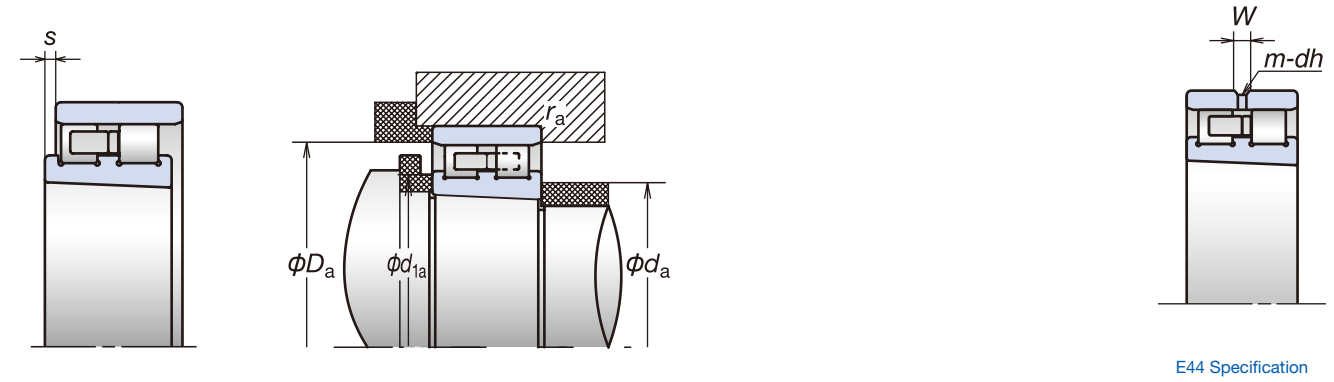
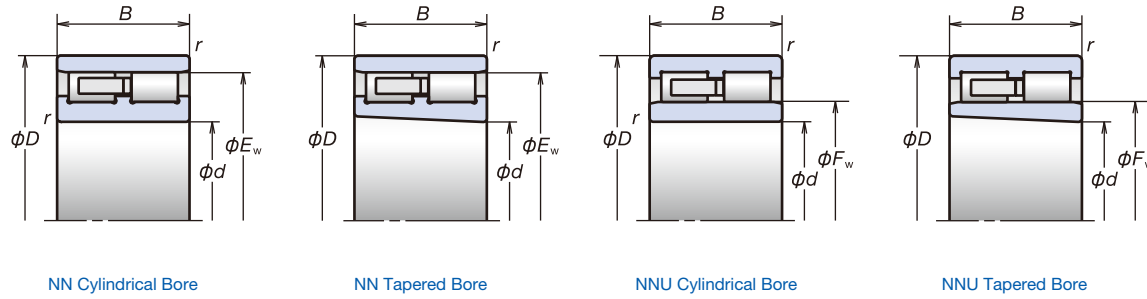

Designation (1)	Boundary Dimensions (mm)				Basic Load Ratings (kN)		E _w (F _w in case of NNU type) (mm) (reference)	Mass (kg) (approx.)	Limiting Speeds (2) (min ⁻¹)	
	d	D	B	r (min.)	C _r (Dynamic)	C _{or} (Static)			Grease	Oil
NN3956MBKR	280	380	75	2.1	695	1 460	355	22.8	2 000	2 500
NN4956KR	280	380	100	2.1	960	2 230	355	30.1	2 000	2 500
NNU4956KR	280	380	100	2.1	960	2 230	309	33.1	2 000	2 500
NN3056KR	280	420	106	4	1 080	2 080	384	47.7	1 900	2 300
NN3960KR	300	420	90	3	855	1 800	388	36.2	1 800	2 300
NN4960KR	300	420	118	3	1 230	2 870	388	47.6	1 800	2 300
NNU4960KR	300	420	118	3	1 230	2 870	336	47.6	1 800	2 300
NN3060KR	300	460	118	4	1 290	2 460	418	66.5	1 800	2 100
NN3964KR	320	440	90	3	880	1 910	408	38.2	1 800	2 100
NN4964KR	320	440	118	3	1 260	3 050	408	50.3	1 800	2 100
NNU4964KR	320	440	118	3	1 260	3 050	356	50.3	1 800	2 100
NN3064KR	320	480	121	4	1 350	2 670	438	71.8	1 700	2 000
NN4968KR	340	460	118	3	1 350	3 400	428	52.6	1 700	2 000
NNU4968KR	340	460	118	3	1 350	3 400	376	52.9	1 700	2 000
NN3068KR	340	520	133	5	1 670	3 300	473	95.6	1 600	1 900
NN3972KR	360	480	90	3	930	2 130	448	42.1	1 600	1 900
NN4972KR	360	480	118	3	1 390	3 550	448	55.1	1 600	1 900
NNU4972KR	360	480	118	3	1 390	3 550	396	55.2	1 600	1 900
NN3072KR	360	540	134	5	1 700	3 450	493	99.7	1 500	1 800
NN3976KR	380	520	106	4	1 250	2 730	484	63.5	1 500	1 800
NN4976KR	380	520	140	4	1 880	4 600	485	81.3	1 500	1 800
NNU4976KR	380	520	140	4	1 880	4 600	421	88.8	1 500	1 800
NN3076KR	380	560	135	5	1 770	3 700	513	113	1 400	1 700
NN4980KR	400	540	140	4	1 940	4 900	505	84.1	1 400	1 700
NNU4980KR	400	540	140	4	1 940	4 900	441	85.1	1 400	1 700
NN3080KR	400	600	148	5	2 090	4 300	548	138	1 300	1 600
NN4984K	420	560	140	4	2 000	5 150	525	87.9	1 200	1 500
NNU4984K	420	560	140	4	2 000	5 150	461	88.4	1 200	1 500
NN3084K	420	620	150	5	2 130	4 450	568	145	1 100	1 400

(3) Axial Displacement (mm)	Abutment and Fillet Dimensions (mm)					Clearances in Bearings with Tapered Bores (μm)						Clearances in Bearings with Cylindrical Bores (μm)		E44 Specification Lubrication Holes Dimensions (mm)		
	s	d _a (min.)	d _{1a} (min.)	D _a (max.) (min.)		r _a (max.)	CC9 (4)		CC0		CC1		CC1		Hole Dia. dh	Oil Groove Width W
1.1	291	295	369	358	2	25	55	40	70	55	110	20	55	5	9	4
2.4	291	295	369	358	2	25	55	40	70	55	110	20	55	6	12	4
2.4	291	295	369	—	2	25	55	40	70	55	110	20	55	6	12	4
3.5	296	298	404	388	3	25	55	40	70	55	110	20	55	6	12	4
2.2	313	318	407	391	2.5	30	60	45	75	60	120	20	60	6	12	4
2.5	313	318	407	391	2.5	30	60	45	75	60	120	20	60	6	12	4
2.5	313	318	407	—	2.5	30	60	45	75	60	120	20	60	6	12	4
4.8	316	319	444	422	3	30	60	45	75	60	120	20	60	6	12	4
2.2	333	338	427	411	2.5	30	65	45	80	65	135	20	65	6	12	4
3.5	333	338	427	411	2.5	30	65	45	80	65	135	20	65	6	12	4
2.5	333	338	427	—	2.5	30	65	45	80	65	135	20	65	6	12	4
5.3	336	340	464	442	3	30	65	45	80	65	135	20	65	8	15	4
3.0	353	363	447	431	2.5	30	65	45	80	65	135	20	65	6	12	4
3.0	353	363	447	—	2.5	30	65	45	80	65	135	20	65	6	12	4
6.8	360	365	500	477	4	30	65	45	80	65	135	20	65	8	15	4
2.2	373	381	467	451	2.5	35	75	50	90	75	150	25	75	6	12	4
3.0	373	383	467	451	2.5	35	75	50	90	75	150	25	75	6	12	4
3.0	373	383	467	—	2.5	35	75	50	90	75	150	25	75	6	12	4
7.0	380	385	520	497	4	35	75	50	90	75	150	25	75	8	15	4
3.5	396	405	504	487	3	35	75	50	90	75	150	25	75	6	12	4
3.8	396	408	504	488	3	35	75	50	90	75	150	25	75	8	15	4
3.8	396	408	504	—	3	35	75	50	90	75	150	25	75	8	15	4
7.3	400	411	540	518	4	35	75	50	90	75	150	25	75	8	15	4
3.5	416	428	524	508	3	35	75	50	90	75	150	25	75	8	15	4
3.5	416	428	524	—	3	35	75	50	90	75	150	25	75	8	15	4
2.3	420	432	580	553	4	35	75	50	90	75	150	25	75	8	15	4
4.0	436	448	544	528	3	40	85	60	105	85	170	25	85	8	15	4
3.5	436	448	544	—	3	40	85	60	105	85	170	25	85	8	15	4
2.8	440	453	600	573	4	40	85	60	105	85	170	25	85	8	15	4

(1) Designations listed here are suffixed with "K" or "KR" to indicate tapered bores (1:12). For cylindrical bores, omit this code.
 (2) For details on limiting speeds, refer to Page 216.
 (3) Axial displacement refers the allowable amount that the outer and inner rings may move from their normal positions in the axial direction.
 (4) Clearance CC9 is applicable to cylindrical roller bearings with tapered bores in ISO Tolerance Classes 5 and 4.

For additional information:
 ● Dynamic Equivalent Load ······P191
 ● Static Equivalent Load ······P198
 ● Nozzle Position ······P240
 ● Recommended Grease Quantities ······P257

Cylindrical Roller Bearings Double Row

2. Cylindrical Roller Bearings

Bore Diameter **440-800mm**

Double-Row Cylindrical Roller Bearings

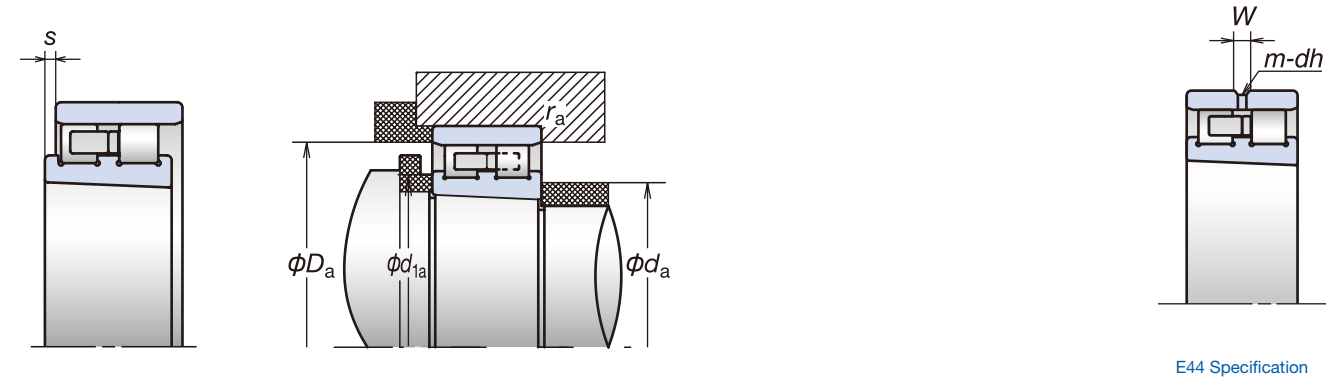
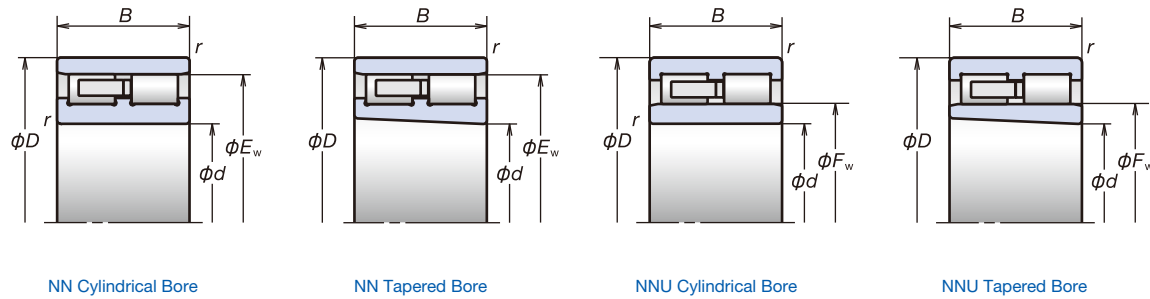

Designation (1)	Boundary Dimensions (mm)				Basic Load Ratings (kN)		E_w (F_w in case of NNU type) (mm) (reference)	Mass (kg) (approx.)	Limiting Speeds (2) (min^{-1})	
	d	D	B	r (min.)	C_r (Dynamic)	C_{or} (Static)			Grease	Oil
NN4988K	440	600	160	4	2 370	6 000	559	123	1 100	1 400
NNU4988K	440	600	160	4	2 370	6 000	487	123	1 100	1 400
NN3088K	440	650	157	6	2 360	4 900	596	166	1 100	1 300
NN3992K	460	620	118	4	1 610	3 700	578	94.5	1 100	1 300
NN4992K	460	620	160	4	2 400	6 200	579	127	1 100	1 300
NNU4992K	460	620	160	4	2 400	6 200	507	128	1 100	1 300
NN3092K	460	680	163	6	2 550	5 350	623	189	1 000	1 300
NN4996K	480	650	170	5	2 690	7 000	607	151	1 000	1 300
NNU4996K	480	650	170	5	2 690	7 000	531	150	1 000	1 300
NN3096K	480	700	165	6	2 600	5 550	643	211	1 000	1 200
NN49/500K	500	670	170	5	2 720	7 200	627	155	1 000	1 200
NNU49/500K	500	670	170	5	2 720	7 200	551	157	1 000	1 200
NN30/500K	500	720	167	6	2 580	5 600	663	205	900	1 200
NN39/530K	530	710	136	5	2 040	4 900	663	139	900	1 200
NN49/530K	530	710	180	5	3 050	8 150	664	185	900	1 200
NNU49/530K	530	710	180	5	3 050	8 150	584	186	900	1 200
NN30/530K	530	780	185	6	3 200	6 900	715	280	900	1 100
NN49/560K	560	750	190	5	3 250	8 700	701	218	900	1 100
NNU49/560K	560	750	190	5	3 250	8 700	617	230	900	1 100
NN49/600K	600	800	200	5	3 850	10 500	749	273	800	1 000
NNU49/600K	600	800	200	5	3 850	10 500	659	284	800	1 000
NN49/630K	630	850	218	6	4 200	11 400	793	328	800	1 000
NNU49/630K	630	850	218	6	4 200	11 400	697	328	800	1 000
NN49/670K	670	900	230	6	4 150	11 500	838	419	700	900
NNU49/670K	670	900	230	6	4 150	11 500	742	381	700	900
NNU49/710BK	710	950	243	6	4 450	12 600	775	472	700	900
NNU49/750K	750	1 000	250	6	5 500	15 900	826	530	700	800
NNU49/800K	800	1 060	258	6	5 700	16 500	879	573	600	800

(3) Axial Displacement (mm)	Abutment and Fillet Dimensions (mm)					Clearances in Bearings with Tapered Bores (μm)						Clearances in Bearings with Cylindrical Bores (μm)			E44 Specification Lubrication Holes Dimensions (mm)		
	s	d_a (min.)	d_{1a} (min.)	D_a (max.) (min.)		r_a (max.)	CC9 (4)		CC0		CC1		CC1		Hole Dia.	Oil Groove Width	Number of Holes
						min.	max.	min.	max.	min.	max.	min.	max.	dh	W	m	
3.3	456	469	584	562	3	40	85	60	105	85	170	25	85	8	15	4	
3.3	456	469	584	—	3	40	85	60	105	85	170	25	85	8	15	4	
3.0	466	479	624	601	5	40	85	60	105	85	170	25	85	8	15	4	
3.8	476	486	604	581	3	45	95	70	120	95	190	25	95	6	12	4	
3.3	476	489	604	582	3	45	95	70	120	95	190	25	95	8	15	4	
3.3	476	489	604	—	3	45	95	70	120	95	190	25	95	8	15	4	
3.5	486	500	654	628	5	45	95	70	120	95	190	25	95	10	18	4	
2.0	500	514	630	610	4	45	95	70	120	95	190	25	95	10	18	4	
2.0	500	514	630	—	4	45	95	70	120	95	190	25	95	10	18	4	
4.3	506	520	674	648	5	45	95	70	120	95	190	25	95	10	18	4	
3.8	520	534	650	630	4	45	95	70	120	95	190	25	95	10	18	4	
3.8	520	534	650	—	4	45	95	70	120	95	190	25	95	10	18	4	
5.5	526	540	694	668	5	45	95	70	120	95	190	25	95	10	18	4	
4.0	550	561	690	668	4	50	105	80	135	105	210	30	105	8	15	4	
3.0	550	565	690	667	4	50	105	80	135	105	210	30	105	10	18	4	
3.0	550	565	690	—	4	50	105	80	135	105	210	30	105	10	18	4	
4.2	556	571	754	720	5	50	105	80	135	105	210	30	105	10	18	4	
2.3	580	596	730	704	4	50	105	80	135	105	210	30	105	10	18	4	
2.2	580	596	730	—	4	50	105	80	135	105	210	30	105	10	18	4	
3.3	620	637	780	752	4	55	115	85	145	115	230	30	115	10	18	4	
3.3	620	637	780	—	4	55	115	85	145	115	230	30	115	10	18	4	
2.8	656	674	824	796	5	55	115	85	145	115	230	30	115	12	20	4	
2.7	656	674	824	—	5	55	115	85	145	115	230	30	115	12	20	4	
6.3	696	715	874	841	5	60	130	90	160	130	260	30	130	12	20	4	
6.2	696	715	874	—	5	60	130	90	160	130	260	30	130	12	20	4	
11.4	736	756	924	—	5	60	130	90	160	130	260	30	130	12	20	4	
7.1	776	797	974	—	5	70	150	110	190	145	290	35	145	12	20	4	
8.9	826	848	1 034	—	5	70	150	110	190	145	290	35	145	12	20	4	

(1) Designations listed here are suffixed with "K" or "KR" to indicate tapered bores (1:12). For cylindrical bores, omit this code.
 (2) For details on limiting speeds, refer to Page 216.
 (3) Axial displacement refers the allowable amount that the outer and inner rings may move from their normal positions in the axial direction.
 (4) Clearance CC9 is applicable to cylindrical roller bearings with tapered bores in ISO Tolerance Classes 5 and 4.

For additional information:
 ● Dynamic Equivalent Load ······ P191
 ● Static Equivalent Load ······ P198
 ● Nozzle Position ······ P240
 ● Recommended Grease Quantities ··· P257

Cylindrical Roller Bearings Double Row



High-Speed Angular Contact Thrust Ball Bearings
NSKROBUST™ Series

BASIC Series



Angular Contact Thrust Ball Bearings

NSKTAC F Series



Double-Direction Angular Contact Thrust Ball Bearings

NSKTAC D Series

Angular Contact Thrust Ball Bearings

Angular Contact Thrust Ball Bearings130-141

Features

Numbering System

Bearing Tables

High-Speed Angular Contact Thrust Ball Bearings (NSKROBUST Series)

Angular Contact Thrust Ball Bearings (NSKTAC F Series)

Double-Direction Angular Contact Thrust Ball Bearings (NSKTAC D Series)

Angular Contact Thrust Ball Bearings

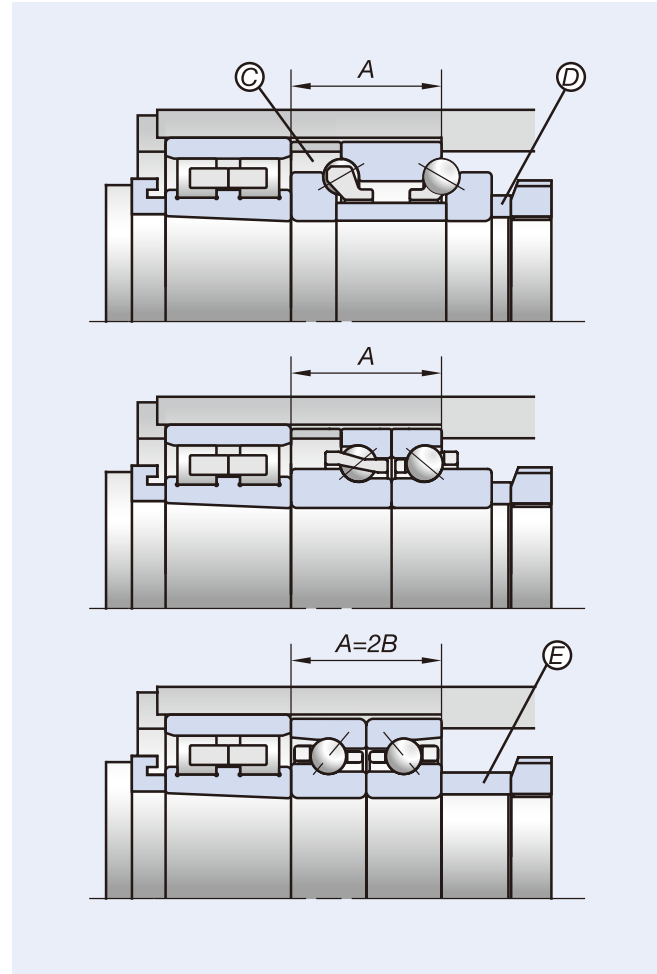

Features

Superior high-speed capability and high rigidity are required of ball bearings used for sustaining axial loads in machine tool spindles. For such application requirements, NSK offers three types of bearings for customers to choose from depending on the structure and the characteristics of the machine.

All of these bearings are designed for use in combination with cylindrical roller bearings. They are manufactured with special outer ring outside diameter tolerances in order to provide clearance between the outside diameter of the bearing and the inner diameter of the housing when mounted, so that any radial load is supported by the cylindrical roller bearings only.

The high-speed angular contact thrust ball bearings of the NSKROBUST series are capable of high-speed performance while maintaining high rigidity. Contact angles of 40° (BTR) and 30° (BAR) result in superior high-speed performance and low heat generation.

Interchangeability

The BAR and BTR Series have special width dimensions to enable customers to easily replace their angular contact thrust ball bearings of the 20 Series with the BAR and BTR type without having to modify the shaft or housing. As shown in the figure on the left, remove spacer (C) and replace spacer (D) with spacer (E).

For the replacement of 29 Series bearings with BAR and BTR type bearings, please contact NSK.

Numbering System of High-Speed Angular Contact Thrust Ball Bearings (NSKROBUST Series)

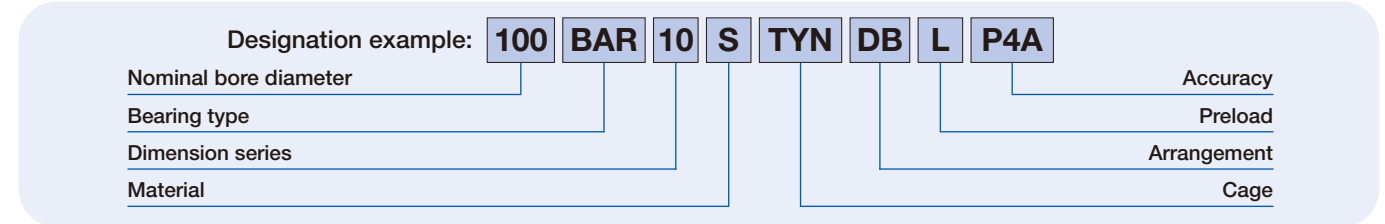

			Reference pages	
100	Nominal bore diameter	Bore diameter (mm)	132-137	
BAR	Bearing type	BAR: 30° contact angle BTR: 40° contact angle	26, 44-45	
10	Dimension series	10: 10 Series bore and outside diameter, special width	132-137	
S	Material	Type	14-17, 26	
		Material		
		S		Bearing steel (SUJ2) Bearing steel (SUJ2)
		E		Bearing steel (SUJ2) Ultra long life bearing rolling elements (EQTF)
H	Bearing steel (SUJ2) Ceramics (Si ₃ N ₄)			
TYN	Cage	TYN: Rolling element guided polyamide cage; limiting speed $d_m n = 1.2$ million (grease), 1.4 million (oil) MY: Rolling element guided machined brass cage No code: Outer ring guided machined brass cage TYN cage is available up to 160mm bore diameter bearings	18	
DB	Arrangement	DB: Back-to-back arrangement	200-205	
L	Preload	L: Light preload (standard for this series) EL: Extra light preload	132-137, 210	
P4A	Accuracy	P2A: Outside diameter tolerances are NSK-specific, all others are ISO Class 2 P4A: Outside diameter tolerances are NSK-specific, all others are ISO Class 4	228	

Numbering System of Angular Contact Thrust Ball Bearings (NSKTAC F Series)

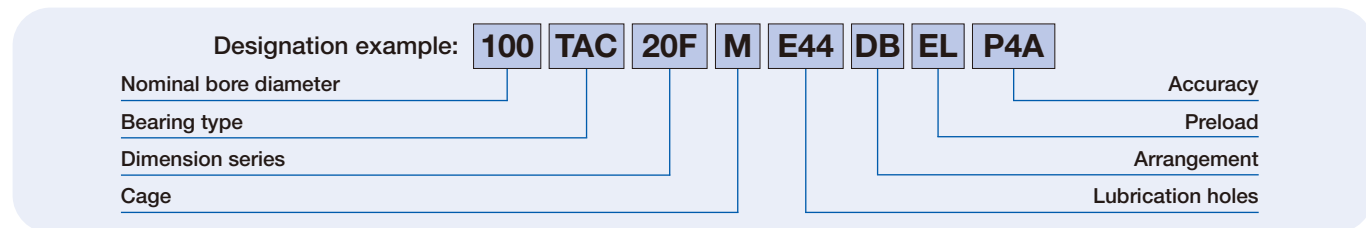

			Reference pages
100	Nominal bore diameter	Bore diameter (mm) (50-130mm)	138-139
TAC	Bearing type	TAC: Angular contact thrust ball bearing	26
20F	Dimension series	20F: For combination with NN30 series 29F: For combination with NN39 and NN49 series	138-139
M	Cage	M: Machined brass cage	—
E44	Lubrication holes	No code: No lubrication holes E44: Lubrication groove and lubrication holes on outer ring	138-139
DB	Arrangement	DB: Back-to-back arrangement	200-205
EL	Preload	L: Light preload (standard for this series) EL: Extra light preload	210
P4A	Preload	P4A: Outside diameter tolerances are NSK-specific, all others are ISO Class 4 P5A: Outside diameter tolerances are NSK-specific, all others are ISO Class 5	228

Numbering System of Double-Direction Angular Contact Thrust Ball Bearings (NSKTAC D Series)

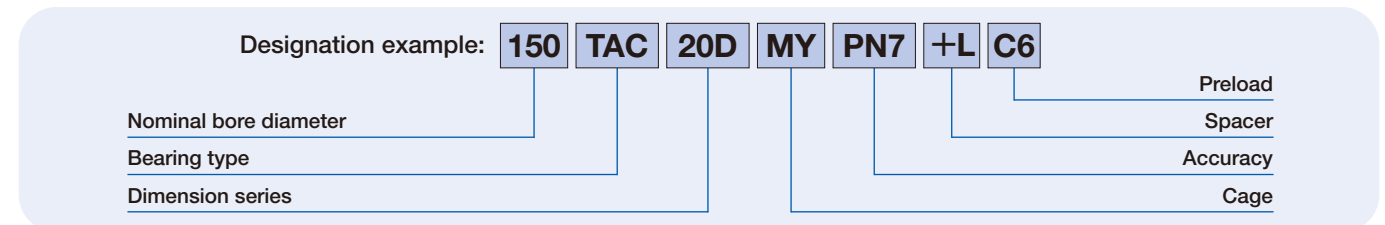

			Reference pages
150	Nominal bore diameter	Bore diameter (mm) (140-320mm)	140-141
TAC	Bearing type	TAC: Angular contact thrust ball bearing	26
20D	Dimension series	20D, 20X: For combination with NN30 series 29D: For combination with NN39 and NN49 series	140-141
MY	Cage	MY: Machined brass cage	—
PN7	Accuracy	PN7: Special precision accuracy	228
+L	Spacer	Inner ring spacer	—
C6	Preload	C6: Extra light preload C7: Light preload (standard for this series) C8: Medium preload	140-141

3. Angular Contact Thrust Ball Bearings

Bore Diameter **50-85mm**

High-Speed Angular Contact Thrust Ball Bearings
(NSK ROBUST Series)

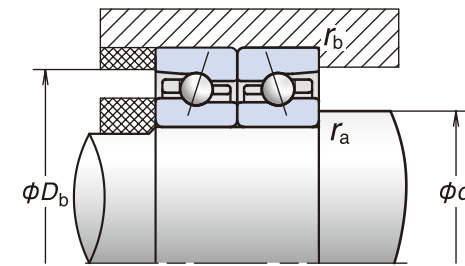
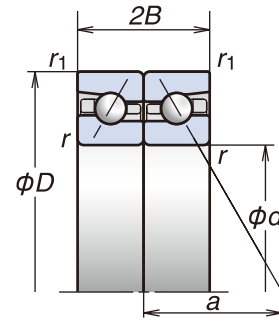

Designation	Boundary Dimensions (mm)					Basic Load Ratings (kN)		Permissible Axial Load (kN)	Contact Angle (°)	Effective Load Center (mm) a	Mass (kg/row) (Reference)	Limiting Speeds (°) (min ⁻¹)	
	d	D	2B	r (min.)	r ₁ (min.)	C _a (Dynamic)	C _{0a} (Static)					Grease	Oil
50BAR10E	50	80	28.5	1	0.6	18.5	27.7	18.4	30	25.6	0.272	12 400	15 700
50BAR10H	50	80	28.5	1	0.6	18.5	26.5	12.6	30	25.6	0.257	13 100	16 200
50BTR10E	50	80	28.5	1	0.6	22.0	31.5	19.3	40	34.1	0.272	10 800	14 000
50BTR10H	50	80	28.5	1	0.6	22.0	30.0	15.5	40	34.1	0.257	11 600	14 700
55BAR10E	55	90	33	1.1	0.6	22.9	35.0	23.4	30	28.9	0.390	11 100	14 100
55BAR10H	55	90	33	1.1	0.6	22.9	33.5	16.0	30	28.9	0.369	11 800	14 500
55BTR10E	55	90	33	1.1	0.6	27.2	40.0	23.6	40	38.3	0.390	9 700	12 600
55BTR10H	55	90	33	1.1	0.6	27.2	38.0	19.7	40	38.3	0.369	10 400	13 200
60BAR10E	60	95	33	1.1	0.6	23.8	38.0	25.5	30	30.4	0.420	10 400	13 200
60BAR10H	60	95	33	1.1	0.6	23.8	36.5	17.5	30	30.4	0.397	11 000	13 600
60BTR10E	60	95	33	1.1	0.6	28.2	43.5	25.8	40	40.4	0.420	9 100	11 800
60BTR10H	60	95	33	1.1	0.6	28.2	41.5	21.5	40	40.4	0.397	9 700	12 300
65BAR10E	65	100	33	1.1	0.6	24.6	41.5	27.7	30	31.8	0.450	9 700	12 400
65BAR10H	65	100	33	1.1	0.6	24.6	39.5	19.0	30	31.8	0.425	10 400	12 800
65BTR10E	65	100	33	1.1	0.6	29.2	47.0	27.3	40	42.5	0.450	8 500	11 100
65BTR10H	65	100	33	1.1	0.6	29.2	45.0	23.3	40	42.5	0.425	9 100	11 600
70BAR10E	70	110	36	1.1	0.6	34.0	55.0	37.5	30	34.7	0.601	8 900	11 400
70BAR10H	70	110	36	1.1	0.6	34.0	53.0	25.5	30	34.7	0.561	9 500	11 700
70BTR10E	70	110	36	1.1	0.6	40.5	63.0	35.0	40	46.3	0.601	7 800	10 200
70BTR10H	70	110	36	1.1	0.6	40.5	60.0	31.5	40	46.3	0.561	8 400	10 600
75BAR10E	75	115	36	1.1	0.6	34.5	57.5	39.0	30	36.1	0.634	8 500	10 800
75BAR10H	75	115	36	1.1	0.6	34.5	55.5	26.7	30	36.1	0.592	9 000	11 100
75BTR10E	75	115	36	1.1	0.6	41.0	65.5	36.5	40	48.4	0.634	7 400	9 600
75BTR10H	75	115	36	1.1	0.6	41.0	63.0	33.0	40	48.4	0.592	7 900	10 000
80BAR10E	80	125	40.5	1.1	0.6	40.0	68.5	46.5	30	39.4	0.830	7 900	10 000
80BAR10H	80	125	40.5	1.1	0.6	40.0	65.5	32.0	30	39.4	0.776	8 300	10 300
80BTR10E	80	125	40.5	1.1	0.6	48.0	78.0	43.0	40	52.7	0.830	6 900	8 900
80BTR10H	80	125	40.5	1.1	0.6	48.0	74.5	39.0	40	52.7	0.776	7 400	9 300
85BAR10E	85	130	40.5	1.1	0.6	40.5	71.5	48.5	30	41.1	0.983	7 500	9 500
85BAR10H	85	130	40.5	1.1	0.6	40.5	68.5	33.0	30	41.1	0.926	8 000	9 800
85BTR10E	85	130	40.5	1.1	0.6	48.5	81.5	43.5	40	55.2	0.983	6 600	8 500
85BTR10H	85	130	40.5	1.1	0.6	48.5	78.0	41.0	40	55.2	0.926	7 000	8 900

Abutment and Fillet Dimensions (mm)				Preload (DB and DF Arrangement) (N)		Axial Rigidity (DB and DF Arrangement) (N/μm)		Measured Axial Clearance (μm)	
d _a (min.)	D _b (max.)	r _a (max.)	r _b (max.)	EL	L	EL	L	EL	L
56	75	1	0.6	221	464	169	220	- 5	- 10
56	75	1	0.6	246	531	196	257	- 5	- 10
56	75	1	0.6	335	761	292	387	- 5	- 10
56	75	1	0.6	379	879	341	455	- 5	- 10
62	85	1	0.6	229	606	177	250	- 5	- 12
62	85	1	0.6	256	696	206	293	- 5	- 12
62	85	1	0.6	349	800	307	409	- 5	- 10
62	85	1	0.6	396	924	359	480	- 5	- 10
67	90	1	0.6	241	646	190	270	- 5	- 12
67	90	1	0.6	270	743	221	316	- 5	- 12
67	90	1	0.6	371	855	331	441	- 5	- 10
67	90	1	0.6	421	990	387	518	- 5	- 10
72	95	1	0.6	253	687	203	289	- 5	- 12
72	95	1	0.6	284	791	236	339	- 5	- 12
72	95	1	0.6	392	912	354	473	- 5	- 10
72	95	1	0.6	446	1 056	414	556	- 5	- 10
77	105	1	0.6	252	908	202	317	- 5	- 15
77	105	1	0.6	282	1 051	235	373	- 5	- 15
77	105	1	0.6	390	1 556	352	566	- 5	- 15
77	105	1	0.6	444	1 815	412	668	- 5	- 15
82	110	1	0.6	258	939	209	329	- 5	- 15
82	110	1	0.6	290	1 088	243	387	- 5	- 15
82	110	1	0.6	402	1 612	365	588	- 5	- 15
82	110	1	0.6	458	1 881	427	694	- 5	- 15
87	120	1	0.6	346	1 095	237	356	- 5	- 15
87	120	1	0.6	382	1 256	275	417	- 5	- 15
87	120	1	0.6	507	1 819	406	630	- 5	- 15
87	120	1	0.6	569	2 107	473	741	- 5	- 15
92	125	1	0.6	354	1 129	245	369	- 5	- 15
92	125	1	0.6	391	1 295	284	432	- 5	- 15
92	125	1	0.6	520	1 879	420	653	- 5	- 15
92	125	1	0.6	584	2 177	489	768	- 5	- 15

(¹) For details on permissible axial load, refer to Page 199.

(²) For details on limiting speeds, refer to Page 216. Limiting speeds listed on this page are based on a DB arrangement with extra light preload (EL).

Adjust the limiting speed to 85% of the figure shown when a light preload (L) has been selected.

For additional information:

- Dynamic Equivalent Load ······P191
- Static Equivalent Load ······P198
- Spacer Dimensions and Nozzle Position ···P237
- Recommended Grease Quantities ···P257

Angular Contact Thrust Ball Bearings

NSK ROBUST

3. Angular Contact Thrust Ball Bearings

Bore Diameter **90-140**mm

High-Speed Angular Contact Thrust Ball Bearings
(NSK ROBUST Series)

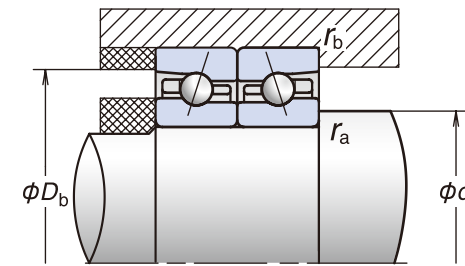
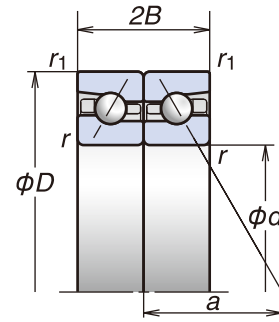

Designation	Boundary Dimensions (mm)					Basic Load Ratings (kN)		Permissible Axial Load (kN)	Contact Angle (°)	Effective Load Center (mm) a	Mass (kg/row) (Reference)	Limiting Speeds (°) (min ⁻¹)	
	d	D	2B	r (min.)	r1 (min.)	Ca (Dynamic)	Coa (Static)					Grease	Oil
90BAR10E	90	140	45	1.5	1	53.0	92.5	62.5	30	44.4	1.21	7 000	8 900
90BAR10H	90	140	45	1.5	1	53.0	88.5	43.0	30	44.4	1.12	7 400	9 200
90BTR10E	90	140	45	1.5	1	63.0	105	58.0	40	59.5	1.21	6 100	8 000
90BTR10H	90	140	45	1.5	1	63.0	101	52.5	40	59.5	1.12	6 600	8 300
95BAR10E	95	145	45	1.5	1	54.0	96.5	65.0	30	45.5	1.25	6 700	8 500
95BAR10H	95	145	45	1.5	1	54.0	92.0	44.5	30	45.5	1.16	7 100	8 800
95BTR10E	95	145	45	1.5	1	64.5	110	61.0	40	61.0	1.25	5 900	7 600
95BTR10H	95	145	45	1.5	1	64.5	105	55.0	40	61.0	1.16	6 300	8 000
100BAR10E	100	150	45	1.5	1	55.0	100	68.0	30	47.3	1.31	6 400	8 200
100BAR10H	100	150	45	1.5	1	55.0	96.0	46.5	30	47.3	1.22	6 800	8 400
100BTR10E	100	150	45	1.5	1	65.0	114	73.0	40	63.7	1.31	5 600	7 300
100BTR10H	100	150	45	1.5	1	65.0	109	57.0	40	63.7	1.22	6 000	7 600
105BAR10E	105	160	49.5	2	1	62.0	115	78.0	30	50.6	1.74	6 100	7 700
105BAR10H	105	160	49.5	2	1	62.0	110	53.5	30	50.6	1.62	6 500	8 000
105BTR10E	105	160	49.5	2	1	74.0	131	74.5	40	68.0	1.74	5 300	6 900
105BTR10H	105	160	49.5	2	1	74.0	125	65.5	40	68.0	1.62	5 700	7 200
110BAR10E	110	170	54	2	1	70.0	131	89.0	30	53.9	1.97	5 800	7 300
110BAR10H	110	170	54	2	1	70.0	125	60.5	30	53.9	1.83	6 100	7 500
110BTR10E	110	170	54	2	1	83.0	148	82.5	40	72.2	1.97	5 000	6 500
110BTR10H	110	170	54	2	1	83.0	142	74.5	40	72.2	1.83	5 400	6 800
120BAR10E	120	180	54	2	1	72.0	141	96.0	30	56.8	2.29	5 400	6 800
120BAR10H	120	180	54	2	1	72.0	135	65.5	30	56.8	2.14	5 700	7 000
120BTR10E	120	180	54	2	1	85.5	160	88.5	40	76.4	2.29	4 700	6 100
120BTR10H	120	180	54	2	1	85.5	153	80.5	40	76.4	2.14	5 000	6 400
130BAR10E	130	200	63	2	1	91.0	172	117	30	63.3	3.20	4 900	6 200
130BAR10H	130	200	63	2	1	91.0	164	79.5	30	63.3	2.98	5 200	6 400
130BTR10E	130	200	63	2	1	108	195	106	40	85.0	3.20	4 300	5 600
130BTR10H	130	200	63	2	1	108	187	98.0	40	85.0	2.98	4 600	5 800
140BAR10E	140	210	63	2	1	99.0	200	135	30	66.2	3.56	4 600	5 900
140BAR10H	140	210	63	2	1	99.0	191	92.5	30	66.2	3.30	4 900	6 000
140BTR10E	140	210	63	2	1	117	227	84.0	40	89.2	3.56	4 000	5 200
140BTR10H	140	210	63	2	1	117	217	100	40	89.2	3.30	4 300	5 500

Abutment and Fillet Dimensions (mm)				Preload (DB and DF Arrangement) (N)		Axial Rigidity (DB and DF Arrangement) (N/μm)		Measured Axial Clearance (μm)	
da (min.)	Db (max.)	ra (max.)	rb (max.)	EL	L	EL	L	EL	L
99	134	1.5	0.8	360	1 662	252	431	- 5	- 20
99	134	1.5	0.8	398	1 922	292	506	- 5	- 20
99	134	1.5	0.8	532	2 834	433	768	- 5	- 20
99	134	1.5	0.8	598	3 303	504	906	- 5	- 20
104	139	1.5	0.8	368	1 717	260	447	- 5	- 20
104	139	1.5	0.8	408	1 986	301	525	- 5	- 20
104	139	1.5	0.8	546	2 931	448	797	- 5	- 20
104	139	1.5	0.8	614	3 417	521	940	- 5	- 20
109	144	1.5	0.8	376	1 770	268	462	- 5	- 20
109	144	1.5	0.8	417	2 049	311	543	- 5	- 20
109	144	1.5	0.8	559	3 029	462	825	- 5	- 20
109	144	1.5	0.8	630	3 531	539	973	- 5	- 20
115	154	2	1	384	1 820	276	476	- 5	- 20
115	154	2	1	426	2 107	320	560	- 5	- 20
115	154	2	1	573	3 121	477	852	- 5	- 20
115	154	2	1	645	3 640	556	1 005	- 5	- 20
120	164	2	1	391	1 868	284	489	- 5	- 20
120	164	2	1	434	2 164	329	576	- 5	- 20
120	164	2	1	586	3 210	490	877	- 5	- 20
120	164	2	1	661	3 746	572	1 035	- 5	- 20
130	174	2	1	408	1 982	301	523	- 5	- 20
130	174	2	1	454	2 298	350	615	- 5	- 20
130	174	2	1	615	3 417	522	938	- 5	- 20
130	174	2	1	694	3 989	609	1 107	- 5	- 20
140	194	2	1	394	2 532	286	547	- 5	- 25
140	194	2	1	437	2 945	332	644	- 5	- 25
140	194	2	1	591	4 411	496	985	- 5	- 25
140	194	2	1	667	5 163	578	1 163	- 5	- 25
150	204	2	1	580	3 154	359	649	- 5	- 25
150	204	2	1	634	3 642	414	762	- 5	- 25
150	204	2	1	823	5 365	610	1 157	- 5	- 25
150	204	2	1	916	6 248	708	1 364	- 5	- 25

(¹) For details on permissible axial load, refer to Page 199.

(²) For details on limiting speeds, refer to Page 216. Limiting speeds listed on this page are based on a DB arrangement with extra light preload (EL).
Adjust the limiting speed to 85% of the figure shown when a light preload (L) has been selected.

For additional information:

- Dynamic Equivalent Load ······P191
- Static Equivalent Load ······P198
- Spacer Dimensions and Nozzle Position ···P237
- Recommended Grease Quantities ···P257

Angular Contact Thrust Ball Bearings

NSK ROBUST

3. Angular Contact Thrust Ball Bearings

Bore Diameter **150-380mm**

High-Speed Angular Contact Thrust Ball Bearings
(NSK ROBUST Series)

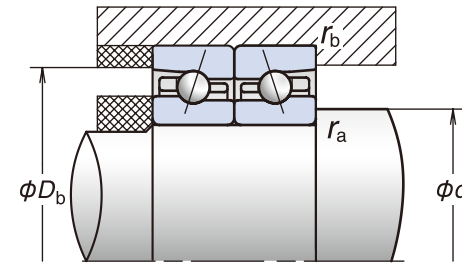
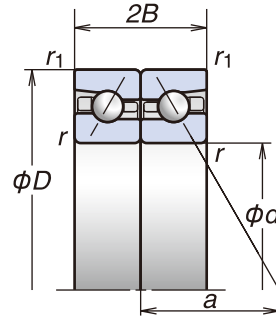

Designation	Boundary Dimensions (mm)					Basic Load Ratings (kN)		Permissible Axial Load (kN)	Contact Angle (°)	Effective Load Center (mm) a	Mass (kg/row) (Reference)	Limiting Speeds (min ⁻¹)	
	d	D	2B	r (min.)	r1 (min.)	Ca (Dynamic)	Coa (Static)					Grease	Oil
150BAR10S	150	225	67.5	2.1	1.1	117	234	160	30	71.0	4.35	4 000	5 100
150BAR10H	150	225	67.5	2.1	1.1	117	224	109	30	71.0	4.03	4 600	5 600
150BTR10S	150	225	67.5	2.1	1.1	138	267	104	40	95.5	4.35	3 500	4 600
150BTR10H	150	225	67.5	2.1	1.1	138	255	123	40	95.5	4.03	4 000	5 100
160BAR10S	160	240	72	2.1	1.1	126	257	175	30	75.7	5.33	3 800	4 800
160BAR10H	160	240	72	2.1	1.1	126	246	120	30	75.7	4.95	4 300	5 300
160BTR10S	160	240	72	2.1	1.1	150	293	184	40	101.9	5.33	3 300	4 300
160BTR10H	160	240	72	2.1	1.1	150	280	147	40	101.9	4.95	3 800	4 800
170BAR10S	170	260	81	2.1	1.1	148	305	207	30	82.3	7.95	3 500	4 500
170BTR10S	170	260	81	2.1	1.1	175	345	204	40	110.5	7.95	3 100	4 000
180BAR10S	180	280	90	2.1	1.1	190	385	262	30	88.8	10.2	3 300	4 200
180BTR10S	180	280	90	2.1	1.1	226	440	271	40	118.9	10.2	2 900	3 700
190BAR10S	190	290	90	2.1	1.1	188	385	263	30	91.8	11.0	3 200	4 000
190BTR10S	190	290	90	2.1	1.1	224	440	255	40	123.2	11.0	2 800	3 600
200BAR10S	200	310	99	2.1	1.1	213	440	300	30	98.3	14.2	3 000	3 800
200BTR10S	200	310	99	2.1	1.1	253	505	292	40	131.7	14.2	2 600	3 400
220BAR10S	220	340	108	3	1.1	238	505	340	30	107.8	18.5	2 400	3 100
220BTR10S	220	340	108	3	1.1	282	575	305	40	144.5	18.5	2 000	2 700
240BAR10S	240	360	108	3	1.1	245	545	370	30	113.5	19.9	2 200	2 900
240BTR10S	240	360	108	3	1.1	291	620	362	40	152.9	19.9	1 900	2 500
260BAR10S	260	400	123	4	1.5	320	765	520	30	125.9	29.0	2 000	2 600
260BTR10S	260	400	123	4	1.5	375	870	463	40	169.2	29.0	1 700	2 300
300BAR10S	300	460	142.5	4	1.5	390	1 020	696	30	145.3	44.9	1 800	2 300
300BTR10S	300	460	142.5	4	1.5	465	1 160	675	40	195.1	44.9	1 500	2 000
360BAR10S	360	540	159	5	2	455	1 320	815	30	169.7	67.6	1 500	1 900
360BTR10S	360	540	159	5	2	540	1 500	870	40	228.5	67.6	1 300	1 700
380BAR10S	380	560	159	5	2	470	1 410	965	30	175.4	69.8	1 400	1 900
380BTR10S	380	560	159	5	2	555	1 600	930	40	236.9	69.8	1 200	1 600

Abutment and Fillet Dimensions (mm)				Preload (DB and DF Arrangement) (N)		Axial Rigidity (DB and DF Arrangement) (N/μm)		Measured Axial Clearance (μm)	
da (min.)	Db (max.)	ra (max.)	rb (max.)	EL	L	EL	L	EL	L
162	218	2	1	584	3 694	364	691	- 5	- 28
162	218	2	1	639	4 278	419	813	- 5	- 28
162	218	2	1	831	5 435	618	1 172	- 5	- 25
162	218	2	1	925	6 330	717	1 382	- 5	- 25
172	233	2	1	591	4 121	370	728	- 5	- 30
172	233	2	1	647	4 780	427	857	- 5	- 30
172	233	2	1	843	5 545	630	1 198	- 5	- 25
172	233	2	1	939	6 458	732	1 412	- 5	- 25
182	253	2	1	604	4 258	383	754	- 5	- 30
182	253	2	1	865	7 366	653	1 355	- 5	- 30
192	273	2	1	606	5 259	385	814	- 5	- 35
192	273	2	1	869	9 183	658	1 467	- 5	- 35
202	283	2	1	606	5 259	385	814	- 5	- 35
202	283	2	1	869	9 184	658	1 467	- 5	- 35
212	303	2	1	617	6 055	396	873	- 5	- 38
212	303	2	1	888	10 629	678	1 577	- 5	- 38
234	333	2.5	1	626	7 839	406	973	- 5	- 45
234	333	2.5	1	905	8 208	695	1 468	- 5	- 31
254	353	2.5	1	651	9 162	431	1 077	- 5	- 48
254	353	2.5	1	947	12 542	740	1 781	- 5	- 40
278	391	3	1.5	1 076	2 325	540	702	-	-
278	391	3	1.5	2 012	10 091	1 008	1 742	-	-
318	451	3	1.5	2 505	5 838	756	1 011	-	-
318	451	3	1.5	4 678	10 874	1 408	1 876	-	-
382	530	4	2	2 801	6 524	845	1 129	-	-
382	530	4	2	5 231	12 157	1 575	2 096	-	-
402	550	4	2	2 982	6 945	899	1 201	-	-
402	550	4	2	5 569	12 942	1 676	2 231	-	-

(¹) For details on permissible axial load, refer to Page 199.
 (²) For details on limiting speeds, refer to Page 216. Limiting speeds listed on this page are based on a DB arrangement with extra light preload (EL).
 Adjust the limiting speed to 85% of the figure shown when a light preload (L) has been selected.

For additional information:
 ● Dynamic Equivalent Load ······P191
 ● Static Equivalent Load ······P198
 ● Spacer Dimensions and Nozzle Position ···P237
 ● Recommended Grease Quantities ···P257

Angular Contact Thrust Ball Bearings

NSK ROBUST

3. Angular Contact Thrust Ball Bearings

Bore Diameter **80-130**mm

Angular Contact Thrust Ball Bearings
(NSKTAC F Series)

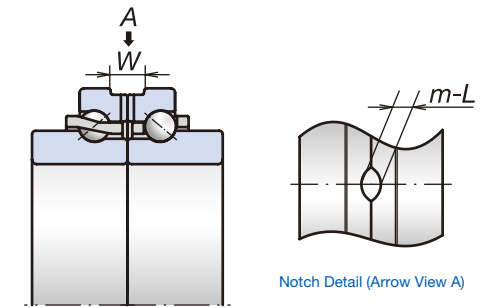
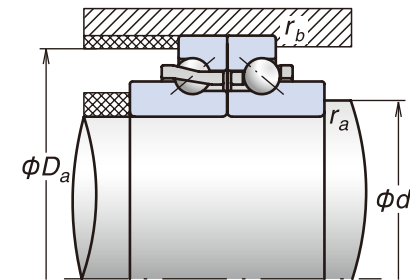
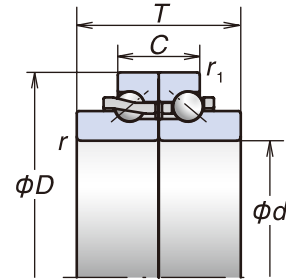

E44 Specification

Designation	Boundary Dimensions (mm)						Basic Load Ratings (kN)		Permissible Axial Load (1) (kN)	Contact Angle (°)	Mass (kg/row) (Reference)	Limiting Speeds (2) (min ⁻¹)	
	d	D	T	C	r (min.)	r1 (min.)	Ca (Dynamic)	Coa (Static)				Grease	Oil
50TAC20F	50	80	38	19	1	0.6	32.0	64.0	10.5	50	0.285	6 900	7 700
55TAC20F	55	90	44	22	1.1	0.6	39.5	81.0	13.3	50	0.442	6 200	6 900
60TAC20F	60	95	44	22	1.1	0.6	41.0	88.5	14.4	50	0.474	5 800	6 500
65TAC20F	65	100	44	22	1.1	0.6	42.5	96.0	15.5	50	0.506	5 500	6 100
70TAC20F	70	110	48	24	1.1	0.6	58.0	127	20.2	50	0.678	5 000	5 600
75TAC20F	75	115	48	24	1.1	0.6	59.0	132	21.0	50	0.717	4 700	5 300
80TAC20F	80	125	54	27	1.1	0.6	69.0	157	25.1	50	1.01	4 400	4 900
85TAC20F	85	130	54	27	1.1	0.6	70.0	164	26.0	50	1.04	4 200	4 700
90TAC20F	90	140	60	30	1.5	1	92.0	213	34.5	50	1.39	3 900	4 300
95TAC20F	95	145	60	30	1.5	1	93.0	222	36.0	50	1.45	3 800	4 200
100TAC29F	100	140	48	24	1.1	0.6	64.5	171	26.8	50	0.917	3 800	4 200
100TAC20F	100	150	60	30	1.5	1	94.5	231	37.0	50	1.47	3 600	4 000
105TAC20F	105	160	66	33	2	1	107	265	42.5	50	1.96	3 400	3 800
110TAC29F	110	150	48	24	1.1	0.6	67.0	187	29.2	50	0.996	3 500	3 800
110TAC20F	110	170	72	36	2	1	121	300	46.0	50	2.45	3 200	3 600
120TAC29F	120	165	54	27	2	1	78.5	223	35.0	50	1.39	3 200	3 500
120TAC20F	120	180	72	36	2	1	124	325	49.0	50	2.63	3 000	3 300
130TAC29F	130	180	60	30	1.5	1	93.5	276	43.5	50	1.89	2 900	3 200
130TAC20F	130	200	84	42	2	1	157	395	61.5	50	3.96	2 700	3 000

(1) For details on permissible axial load, refer to Page 199.

(2) For details on limiting speeds, refer to Page 216. Limiting speeds listed on this page are based on a DB arrangement with extra light preload (EL). Adjust the limiting speed to 85% of the figure shown when a light preload (L) has been selected.

Abutment and Fillet Dimensions (mm)				Preload (N)		Axial rigidity (N/μm)		Measured Axial Clearance (μm)		E44 Specification Lubrication Holes Dimensions (mm)		
da	Da	ra (max.)	rb (max.)	EL	L	EL	L	EL	L	Oil Groove Width W	Notch Width L	Number of Holes m
62	75	1	0.6	549	2 335	530	876	- 5	- 15	8	3	4
69	84	1	0.6	580	2 485	565	934	- 5	- 15	8	3	4
74	89	1	0.6	619	2 677	609	1 010	- 5	- 15	8	3	4
79	94	1	0.6	658	2 868	652	1 086	- 5	- 15	8	3	4
87	104	1	0.6	648	2 814	641	1 062	- 5	- 15	10	4	4
92	109	1	0.6	670	2 920	665	1 104	- 5	- 15	10	4	4
99	117	1	0.6	806	3 236	733	1 181	- 5	- 15	12	5	4
104	122	1	0.6	829	3 348	758	1 225	- 5	- 15	12	5	4
110	131	1.5	1	847	3 428	778	1 254	- 5	- 15	12	5	4
115	136	1.5	1	872	3 548	805	1 301	- 5	- 15	12	5	4
117	134	1	0.6	931	3 839	871	1 418	- 5	- 15	10	4	4
120	141	1.5	1	897	3 667	833	1 348	- 5	- 15	12	5	4
127	150	2	1	925	3 802	864	1 400	- 5	- 15	12	6	4
127	144	1	0.6	996	4 157	944	1 543	- 5	- 15	10	4	4
134	158	2	1	952	3 933	894	1 451	- 5	- 15	14	6	4
139	157	2	1	1 036	4 351	989	1 619	- 5	- 15	10	5	4
144	168	2	1	1 005	4 189	954	1 551	- 5	- 15	14	6	4
150	170	1.5	1	1 102	4 666	1 062	1 741	- 5	- 15	10	5	4
160	187	2	1	956	3 946	898	1 453	- 5	- 15	14	6	4

For additional information:

- Dynamic Equivalent Load ······P191
- Static Equivalent Load ······P198
- Recommended Grease Quantities ···P257

Standard Angular Contact Thrust Ball Bearings

3. Angular Contact Thrust Ball Bearings

Bore Diameter **140-320mm**

Double-Direction Angular Contact Thrust Ball Bearings
(NSKTAC D Series)

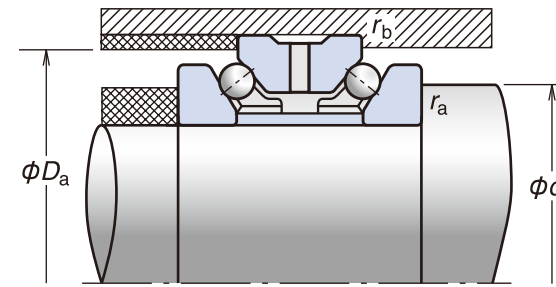
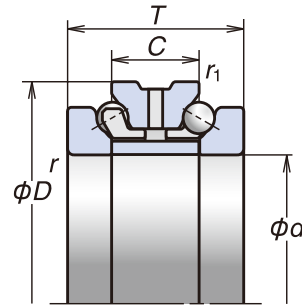

Designation	Boundary Dimensions (mm)						Basic Load Ratings (kN)		Permissible Axial Load ⁽¹⁾ (kN)	Contact Angle (°)	Mass (kg) (Reference)	Limiting Speeds ⁽²⁾ (min ⁻¹)	
	d	D ⁽¹⁾	T	C	r (min.)	r1 (min.)	Ca (Dynamic)	Coa (Static)				Grease	Oil
140TAC20X+L	140	210	84	42	2	1	183	525	325	60	8.67	2 600	2 900
150TAC29D+L	150	210	72	36	2	1	146	465	290	60	6.18	2 500	2 800
150TAC20X+L	150	225	90	45	2.1	1.1	216	620	382	60	10.6	2 400	2 700
160TAC29D+L	160	220	72	36	2	1	149	490	307	60	6.45	2 400	2 700
160TAC20X+L	160	240	96	48	2.1	1.1	233	685	424	60	12.9	2 300	2 500
170TAC29D+L	170	230	72	36	2	1	152	520	324	60	7.35	2 300	2 500
170TAC20X+L	170	260	108	54	2.1	1.1	274	810	497	60	17.6	2 100	2 400
180TAC29D+L	180	250	84	42	2	1	199	655	405	60	9.99	2 100	2 400
180TAC20X+L	180	280	120	60	2.1	1.1	355	1 020	634	60	23.1	2 000	2 200
190TAC29D+L	190	260	84	42	2	1	203	695	428	60	11.0	2 000	2 300
190TAC20D+L	190	290	120	60	2.1	1.1	360	1 060	659	60	24.4	1 900	2 100
200TAC29D+L	200	280	96	48	2.1	1.1	257	855	531	60	15.7	1 900	2 100
200TAC20D+L	200	310	132	66	2.1	1.1	395	1 180	736	60	29.6	1 800	2 000
220TAC29D+L	220	300	96	48	2.1	1.1	265	930	577	60	17.0	1 800	2 000
220TAC20D+L	220	340	144	72	2.1	1.1	455	1 390	856	60	39.1	1 600	1 800
240TAC29D+L	240	320	96	48	2.1	1.1	268	980	608	60	17.0	1 700	1 800
240TAC20D+L	240	360	144	72	3	1.1	455	1 450	893	60	42.2	1 500	1 700
260TAC29D+L	260	360	120	60	2.1	1.1	395	1 390	858	60	30.3	1 500	1 700
260TAC20D+L	260	400	164	82	4	1.5	550	1 890	1 170	60	64.5	1 400	1 600
280TAC29D+L	280	380	120	60	2.1	1.1	400	1 470	909	60	31.3	1 400	1 600
300TAC29D+L	300	420	144	72	3	1.1	500	1 810	1 120	60	50.4	1 200	1 400
320TAC29D+L	320	440	144	72	3	1.1	510	1 920	1 180	60	53.2	1 100	1 300

⁽¹⁾ Outside diameter tolerance is f6.

⁽²⁾ For details on permissible axial load, refer to Page 199.

⁽³⁾ For details on limiting speeds, refer to Page 216. Limiting speeds listed on this page are based on an extra light preload (C6).

Adjust the limiting speed to 85% of the figure shown when a light preload (C7) has been selected and 70% when a medium preload (C8) has been selected.

Abutment and Fillet Dimensions (mm)				Preload (N)			Axial rigidity (N/μm)			Measured Axial Clearance (μm)		
da	Da	ra (max.)	rb (max.)	C6	C7	C8	C6	C7	C8	C6	C7	C8
167	198	2	1	925	3 675	9 343	1 194	1 898	2 603	- 3	- 10	- 20
172	200	2	1	196	4 116	7 085	775	2 152	2 587	0	- 10	- 15
178	213	2	1	934	4 725	9 467	1 210	2 086	2 639	- 3	- 12	- 20
182	210	2	1	196	4 309	7 432	803	2 263	2 722	0	- 10	- 15
191	228	2	1	1 277	4 837	11 088	1 368	2 140	2 833	- 4	- 12	- 22
192	219	2	1	196	4 502	7 780	830	2 374	2 857	0	- 10	- 15
206	245	2	1	2 078	6 745	13 736	1 650	2 451	3 119	- 6	- 15	- 25
207	238	2	1	1 063	4 409	9 795	1 439	2 319	3 038	- 3	- 10	- 18
220	264	2	1	2 982	6 811	15 473	1 876	2 476	3 268	- 8	- 15	- 27
217	247	2	1	1 102	4 617	10 284	1 508	2 439	3 198	- 3	- 10	- 18
230	274	2	1	3 074	7 039	18 620	1 941	2 565	3 564	- 8	- 15	- 30
230	267	2	1	1 098	4 597	11 866	1 502	2 427	3 344	- 3	- 10	- 20
245	291	2	1	3 083	7 714	18 677	1 947	2 650	3 575	- 8	- 16	- 30
250	287	2	1	1 160	4 933	12 790	1 613	2 621	3 616	- 3	- 10	- 20
272	320	2	1	3 247	4 331	19 791	2 063	2 273	3 794	- 8	- 10	- 30
270	307	2	1	1 202	5 156	13 405	1 688	2 750	3 798	- 3	- 10	- 20
290	341	2.5	1	3 345	9 161	20 465	2 133	2 993	3 927	- 8	- 17	- 30
300	344	2	1	1 193	8 859	13 254	1 671	3 274	3 750	- 3	- 15	- 20
316	375	3	1.5	4 232	8 420	22 437	2 461	3 101	4 315	-	-	-
320	364	2	1	1 239	9 313	13 947	1 754	3 451	3 954	- 3	- 15	- 20
348	399	2.5	1	1 717	9 403	16 124	1 970	3 485	4 179	-	-	-
368	419	2.5	1	1 789	9 885	20 384	2 071	3 673	46 89	-	-	-

For additional information:

- Dynamic Equivalent Load ······ P191
- Static Equivalent Load ······ P198
- Recommended Grease Quantities · P257

Double-Direction Angular Contact Thrust Ball Bearings



For High-Rigidity Applications

NSKTAC C Series



For High-Load Drive Applications

NSKTAC 03 Series



Double-Row Bearings

BSBD Series



Units

Units for Ball Screw Support

Ball Screw Support Bearings

NSKHPS Angular Contact Thrust Ball Bearings for Ball Screw Support ... 144-149

- Features
- Numbering System
- Bearing Tables
- For High-Rigidity Applications
 - NSKTAC C Series
- For High-Load Drive Applications
 - NSKTAC 03 Series

NSKHPS Angular Contact Thrust Ball Bearings for Ball Screw Support (Double-Row) 150-153

- Features
- Numbering System
- Bearing Tables
- Double-Row Bearings
 - BSBD Series

Units for Ball Screw Support 154-155

- Features
- Numbering System
- Support Unit Tables

B/S Support

NSKHPS Angular Contact Thrust Ball Bearings for Ball Screw Support

Features

NSKHPS bearings improve reliability by focusing on material cleanliness, which has the biggest impact on bearing life, by employing NSK's proprietary material evaluation technologies to improve dynamic load ratings by 5% compared with conventional bearings.

The NSKTAC C Series features high axial rigidity suitable for machine tool feed mechanisms, while the NSKTAC 03 Series with its high axial load capacity is well-suited for the support of large ball screws in high-load drive applications such as electric injection molding machines. With these series, users can achieve much lower torque and higher accuracy than with roller bearings.

NSKTAC C Angular Contact Thrust Ball Bearings for Ball Screw Support in High-Rigidity Applications

A larger number of balls and a 60° contact angle provide high axial rigidity that makes NSKTAC C bearings ideally suited for machine tool feeding mechanisms.

The DDG seals used for the sealed bearings of this series are light-contact seals for high speeds; a strong sealing effect is achieved by a labyrinth between the seal lip and the seal groove of the inner ring. This ensures that no foreign particles can get into the bearing and no grease can leak out, thus helping to keep the surrounding area clean. Some bearings from this series are also available as non-contact sealed bearings for even lower torque and lower heat generation.

For ease of handling and increased efficiency, NSKTAC C bearings come prepacked with WPH grease that resists high temperatures and is less likely to soften and leak.

NSKTAC 03 Angular Contact Thrust Ball Bearings for Ball Screw Support in High-Load Drive Applications

An optimized internal design provides NSKTAC 03 bearings with higher limiting axial loads, allowing for fewer bearing rows and smaller equipment. We also offer bearings with special bore diameters. That way, bearings with higher load capacity may be employed without any need to modify the shaft diameter, allowing for more compact screw shaft ends.

Please consult with NSK to confirm the suitability of NSKTAC 03 bearings for applications outside of injection molding machines and machine tools.

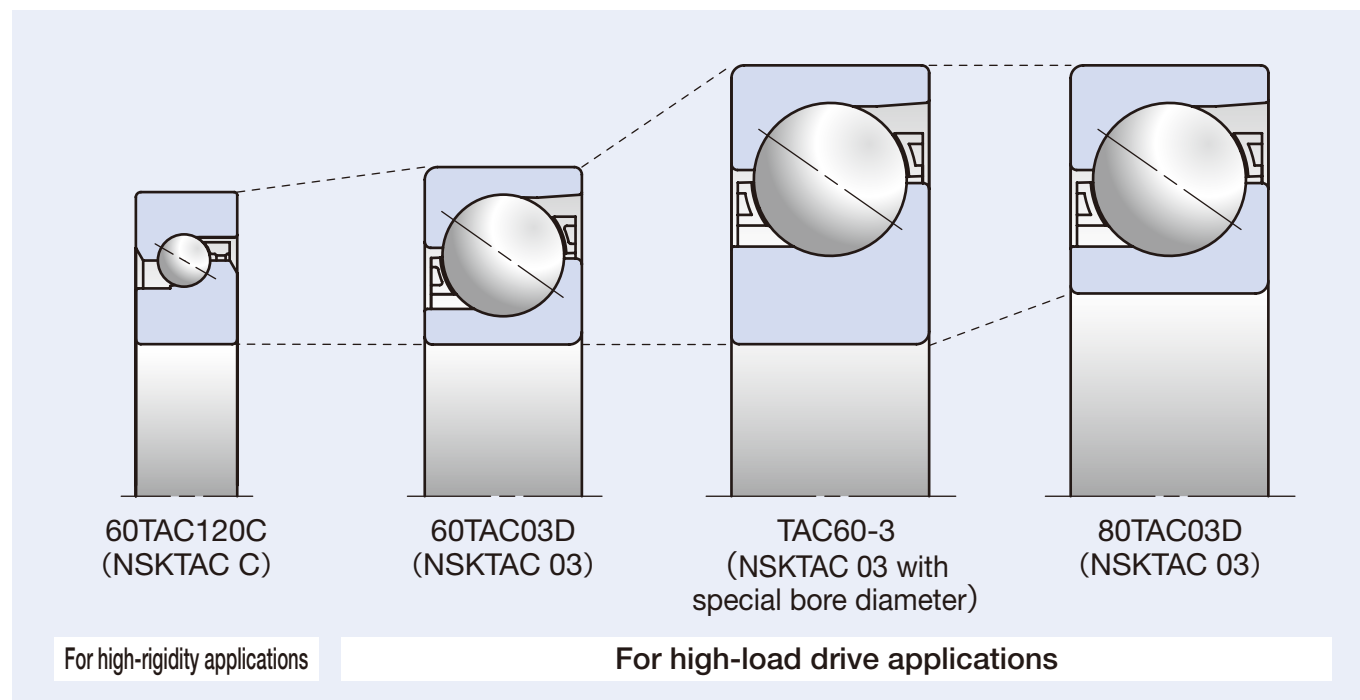

Numbering System for NSKTAC C Angular Contact Thrust Ball Bearings for Ball Screw Support (for High-Rigidity Applications)

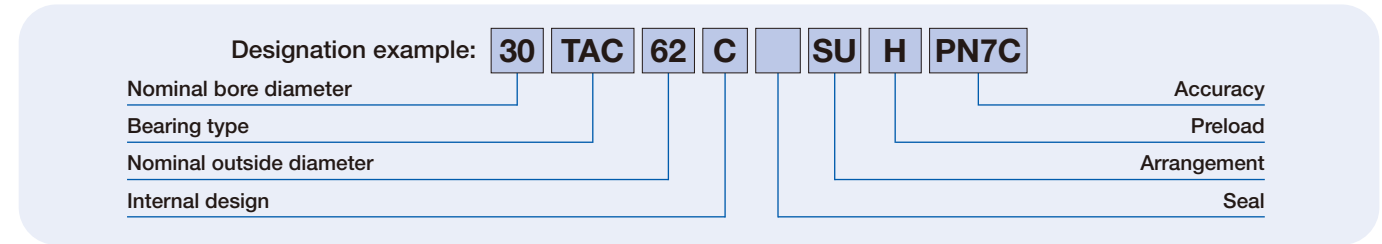

Code	Property	Description	Reference pages
30	Nominal bore diameter	Bore diameter (mm)	146-147
TAC	Bearing type	Angular contact thrust ball bearing	30, 144
62	Nominal outside diameter	Outside diameter (mm)	146-147
C	Internal design	Contact angle 60°	—
	Seal	No code: Open type DDG: Contact rubber seal V1V: Non-contact rubber seal	144
SU	Arrangement	SU: Universal arrangement (single-row)	200-205
H	Preload	H: Heavy preload (standard in the NSKHPS Series)	146-147
PN7C	Accuracy	PN7C: NSKTAC C standard accuracy (NES Class 7C, axial runout equivalent to P2)	229

Numbering System for NSKTAC 03 Angular Contact Thrust Ball Bearings for Ball Screw Support (for High-Load Drive Applications)

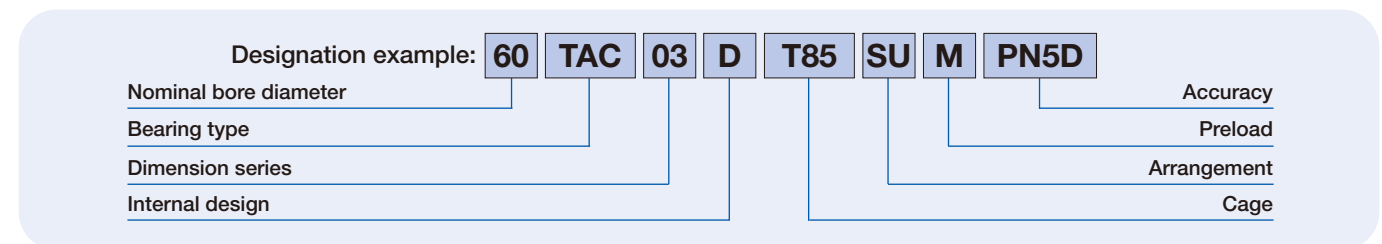

Code	Property	Description	Reference pages
60	Nominal bore diameter	Bore diameter (mm)	148-149
TAC	Bearing type	Angular contact thrust ball bearing	30, 144
03	Dimension series	02: 02 Series 03: 03 Series	144
D	Internal design	Contact angle 55°	—
T85	Cage	T85: Polyamide cage M: Brass Cage	—
SU	Arrangement	SU: Universal arrangement (single-row)	200-205
M	Preload	M: Medium preload EL: Extra light preload	148-149
PN5D	Accuracy	PN5D: NSKTAC 03 standard accuracy (NES Class 5D)	229

NSKHPS is not applicable for TAC100-3 to 180TAC03DM.

4. Ball Screw Support Bearings

Bore Diameter **15-60mm**

for High-Rigidity

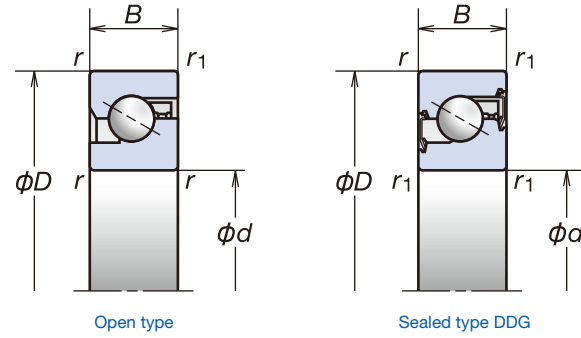

(Open type)

Designation	Boundary Dimensions (mm)					Abutment and Fillet Dimensions (mm)				Recommended Grease Quantities (g/brg)	Contact Angle (°)	Limiting Speeds (°) (min ⁻¹)		Mass (kg) (approx.)
	d	D	B	r (min.)	r ₁ (min.)	D _b (max.)	d _a (min.)	D _a (max.)	d _b (min.)			Grease	Oil	
15TAC47C	15	47	15	1	0.6	42	19.5	41	19.5	2.0	60	6 900	9 200	0.146
17TAC47C	17	47	15	1	0.6	42	23	41	23	2.0	60	6 900	9 200	0.140
20TAC47C	20	47	15	1	0.6	42	25	41	25	2.0	60	6 900	9 200	0.135
25TAC62C	25	62	15	1	0.6	57	31	56	31	2.8	60	5 200	6 900	0.252
30TAC62C	30	62	15	1	0.6	57	36	56	36	3.0	60	4 900	6 400	0.224
30TAC72C	30	72	19	1	0.6	67	36	66	36	4.6	60	4 100	5 800	0.427
35TAC72C	35	72	15	1	0.6	67	42	66	42	3.5	60	4 100	5 800	0.310
40TAC72C	40	72	15	1	0.6	67	47	66	47	3.6	60	4 100	5 500	0.275
40TAC90C	40	90	20	1	0.6	85	48	84	48	8.2	60	3 500	4 600	0.674
45TAC75C	45	75	15	1	0.6	68	54	67	54	3.9	60	3 700	4 900	0.270
45TAC100C	45	100	20	1	0.6	93	55	92	55	9.0	60	3 000	4 100	0.842
50TAC100C	50	100	20	1	0.6	92	60	91	60	9.5	60	3 000	3 900	0.778
55TAC100C	55	100	20	1	0.6	92	63	91	63	9.5	60	3 000	3 900	0.714
55TAC120C	55	120	20	1	0.6	112	63	111	63	11	60	2 500	3 500	1.23
60TAC120C	60	120	20	1	0.6	112	70	111	70	11	60	2 500	3 500	1.16

(Sealed type)

Designation (1)	Boundary Dimensions (mm)					Abutment and Fillet Dimensions (mm)				Contact Angle (°)	Limiting Speeds (°) (min ⁻¹)	Mass (kg) (approx.)
	d	D	B	r (min.)	r ₁ (min.)	D _b (max.)	d _a (min.)	D _a (max.)	d _b (min.)			
*15TAC47CDDG	15	47	15	1	0.6	42	19.5	41	19.5	60	6 900	0.146
*17TAC47CDDG	17	47	15	1	0.6	42	22	41	22	60	6 900	0.140
*20TAC47CDDG	20	47	15	1	0.6	42	25	41	25	60	6 900	0.135
*25TAC62CDDG	25	62	15	1	0.6	57	30	56	30	60	5 200	0.252
30TAC62CDDG	30	62	15	1	0.6	57	36	56	36	60	4 900	0.224
35TAC72CDDG	35	72	15	1	0.6	67	41	66	41	60	4 100	0.310
40TAC72CDDG	40	72	15	1	0.6	67	46	66	46	60	4 100	0.275
40TAC90CDDG	40	90	20	1	0.6	85	47	84	47	60	3 500	0.674
45TAC100CDDG	45	100	20	1	0.6	93	54	92	54	60	3 000	0.842
50TAC100CDDG	50	100	20	1	0.6	92	59	91	59	60	3 000	0.778
55TAC100CDDG	55	100	20	1	0.6	92	63	91	63	60	3 000	0.714

(1) An asterisk (*) indicates bearings that are also available as non-contact sealed bearings.

(2) Limiting speeds are based on high preload (H). The values shown are valid for all types of bearing arrangement.

(3) To calculate permissible axial load, multiply limiting axial load by 0.7.

(4) The starting torque values in the table apply to grease lubricated bearings. Contact seal torque is not included. For oil lubricated bearings, multiply by 1.4.

(5) Abutment and fillet dimensions are recommendable values for the use of standard Machine tool applications. For heavy load applications, please ask NSK

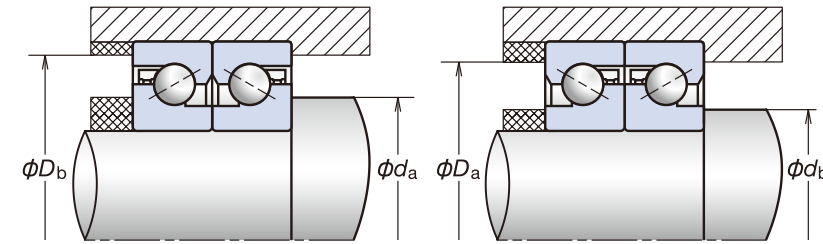

Calculation of preload, axial rigidity and starting torque for bearing arrangements
Multiply by factors in table B.

Table B	DFD	DF	DFT
	DBD	DBB	DBT
Preload factor	1.36	2.00	1.57
Axial rigidity	1.49	2.00	1.89
Starting torque	1.35	2.00	1.55

DB/DF Arrangement H preload				Basic dynamic load rating C _a by number of rows sustaining F _a			Limiting static axial load by number of rows sustaining F _a (°)		
Preload (N)	Axial Rigidity (N/μm)	Starting Torque (°) (N·m)	Measured Axial Clearance (μm)	1 row (kN)	2 rows (kN)	3 rows (kN)	1 row (kN)	2 rows (kN)	3 rows (kN)
1 450	630	0.09	- 13	27.6	45.0	59.5	26.6	53.0	79.5
1 450	630	0.09	- 13	27.6	45.0	59.5	26.6	53.0	79.5
1 450	630	0.09	- 13	27.6	45.0	59.5	26.6	53.0	79.5
2 280	850	0.15	- 15	36.0	58.5	77.5	40.5	81.5	122
2 400	890	0.16	- 15	37.0	59.5	79.5	43.0	86.0	129
2 750	1 030	0.18	- 15	39.0	63.5	84.5	50.0	100	150
2 750	1 030	0.18	- 15	39.0	63.5	84.5	50.0	100	150
2 860	1 080	0.19	- 15	40.0	65.0	86.5	52.0	104	157
3 450	1 150	0.29	- 17	74.5	121	160	89.5	179	269
3 100	1 170	0.20	- 15	41.5	67.0	89.5	57.0	114	170
4 440	1 340	0.40	- 19	77.5	126	167	99.0	198	298
4 650	1 410	0.42	- 19	79.0	129	171	104	208	310
4 650	1 410	0.42	- 19	79.0	129	171	104	208	310
5 450	1 660	0.49	- 19	85.0	138	183	123	246	370
5 450	1 660	0.49	- 19	85.0	138	183	123	246	370

DB and DF Arrangement H preload				Basic dynamic load rating C _a by number of rows sustaining F _a			Limiting static axial load by number of rows sustaining F _a (°)		
Preload (N)	Axial Rigidity (N/μm)	Starting Torque (°) (N·m)	Measured Axial Clearance (μm)	1 row (kN)	2 rows (kN)	3 rows (kN)	1 row (kN)	2 rows (kN)	3 rows (kN)
1 450	630	0.09	- 13	27.6	45.0	59.5	26.6	53.0	79.5
1 450	630	0.09	- 13	27.6	45.0	59.5	26.6	53.0	79.5
1 450	630	0.09	- 13	27.6	45.0	59.5	26.6	53.0	79.5
2 280	850	0.15	- 15	36.0	58.5	77.5	40.5	81.5	122
2 400	890	0.16	- 15	37.0	59.5	79.5	43.0	86.0	129
2 750	1 030	0.18	- 15	39.0	63.5	84.5	50.0	100	150
2 860	1 080	0.19	- 15	40.0	65.0	86.5	52.0	104	157
3 450	1 150	0.29	- 17	74.5	121	160	89.5	179	269
4 440	1 340	0.40	- 19	77.5	126	167	99.0	198	298
4 650	1 410	0.42	- 19	79.0	129	171	104	208	310
4 650	1 410	0.42	- 19	79.0	129	171	104	208	310

for High-Rigidity B/S Support

4. Ball Screw Support Bearings

Bore Diameter **15-180mm**

for High-Load Drive Applications

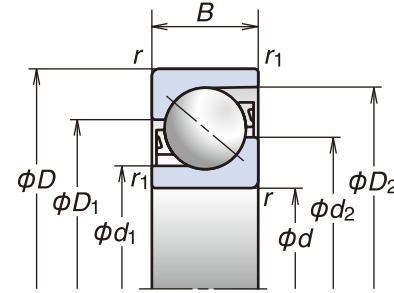

Calculation of preload, axial rigidity and starting torque for bearing arrangements
Multiply by factors in table B.

Table B Number of load-sustaining rows	2 rows		3 rows			4 rows		5 rows
	DFD ○○○	DFF ○○○○	DFT ○○○○○	DFFD ○○○○○○	DFFF ○○○○○○○	DFTD ○○○○○○○	DFFT ○○○○○○○○	DFTT ○○○○○○○○○
Preload factor	1.36	2.00	1.57	2.42	3.00	1.72	2.72	1.83
Axial rigidity	1.49	2.00	1.89	2.51	3.00	2.24	2.97	2.57
Starting torque	1.35	2.00	1.55	2.41	3.00	1.68	2.71	1.77

Designation (*)	Boundary Dimensions (mm)					Reference Dimensions (mm)				Recommended Grease Quantities (g/brg)	Contact Angle (°)	Limiting Speeds (°)		Mass (kg) (approx.)
	d	D	B	r (min.)	r1 (min.)	d1	d2	D1	D2			(min ⁻¹)		
												Grease	Oil	
15TAC02D	15	35	11	0.6	0.3	19.1	24.5	26	31.9	1.0	55	12 000	14 800	0.047
20TAC03D	20	52	15	1.1	0.6	27.2	35.3	37.5	46.1	2.7	55	8 300	10 300	0.155
25TAC02D	25	52	15	1	0.6	30.8	38.1	39.6	47.3	3.0	55	7 700	9 700	0.137
TAC35-3	35	90	23	1.5	1	50.4	64.2	67.1	81.7	13	55	4 600	5 700	0.712
40TAC03D	40	90	23	1.5	1	50.4	64.2	67.1	81.7	13	55	4 600	5 700	0.659
TAC40-3	40	110	27	2	1	62	79.1	82.4	100.6	24	55	3 700	4 700	1.28
45TAC03D	45	100	25	1.5	1	56.5	71.7	74.7	90.8	17	55	4 100	5 200	0.877
TAC45-3	45	110	27	2	1	62	79.1	82.4	100.6	24	55	3 700	4 700	1.21
50TAC03D	50	110	27	2	1	62	79.1	82.4	100.6	24	55	3 700	4 700	1.14
TAC50-3	50	130	31	2.1	1.1	73.9	93.8	98	119	37	55	3 100	3 900	2.00
55TAC03D	55	120	29	2	1	68	86.4	90.2	109.7	30	55	3 400	4 300	1.44
60TAC03D	60	130	31	2.1	1.1	73.9	93.8	98	119	37	55	3 100	3 900	1.80
TAC60-3	60	170	39	2.1	1.1	98.5	123.6	128.7	157.5	79	55	2 400	3 000	4.47
70TAC03D	70	150	35	2.1	1.1	86.3	108.6	113.4	137.8	55	55	2 700	3 400	2.67
75TAC03D	75	160	37	2.1	1.1	92.4	116.2	121	146.2	67	55	2 500	3 200	3.20
80TAC03D	80	170	39	2.1	1.1	98.5	123.6	128.7	157.5	79	55	2 400	3 000	3.80
TAC80-3	80	215	47	3	1.1	124	154.9	160.4	194.5	148	55	1 900	2 400	8.66
100TAC03D	100	215	47	3	1.1	124	154.9	160.4	194.5	148	55	1 900	2 400	7.54
TAC100-3	100	260	55	3	1.1	150.5	186.9	193.4	231.7	237	55	1 500	2 000	14.8
120TAC03D	120	260	55	3	1.1	150.5	186.9	193.4	231.7	237	55	1 500	2 000	13.3
*TAC120-3M	120	300	62	4	1.5	174.3	216.4	223.6	268.3	299	55	1 300	1 700	24.4
*140TAC03DM	140	300	62	4	1.5	174.3	216.4	223.6	268.3	299	55	1 300	1 700	22.4
*TAC140-3M	140	340	68	4	1.5	201.2	246.2	254.3	301.6	395	55	1 200	1 500	34.1
*160TAC03DM	160	340	68	4	1.5	201.2	246.2	254.3	301.6	395	55	1 200	1 500	31.6
*TAC160-3M	160	380	75	4	1.5	227.0	275.6	284.9	338.8	538	55	1 000	1 400	47.0
*180TAC03DM	180	380	75	4	1.5	227.0	275.6	284.9	338.8	538	55	1 000	1 400	43.8

(*) An asterisk (*) indicates bearings that are also available equipped with screw holes for mounting bolts.
 (°) Limiting speeds are based on the standard preload of each bearing. The values shown are valid for all types of bearing arrangement.
 (°) The starting torque values in the table apply to grease lubrication.
 (°) To calculate permissible axial load, multiply limiting axial load by 0.7.

Preload	DB and DF Arrangement				Basic dynamic load rating Ca by number of rows sustaining Fa					Limiting static axial load by number of rows sustaining Fa (°)				
	Preload (N)	Axial Rigidity (N/μm)	Starting Torque (°) (N·m)	Measured Axial Clearance (μm)	1 row (kN)	2 rows (kN)	3 rows (kN)	4 rows (kN)	5 rows (kN)	1 row (kN)	2 rows (kN)	3 rows (kN)	4 rows (kN)	5 rows (kN)
M	400	290	0.017	- 7	25.1	41.0	54.0	66.5	77.5	18.6	37.5	56.0	74.5	93.0
M	830	430	0.026	- 10	51.0	83.0	110	135	158	38.5	77.0	116	154	193
M	690	430	0.036	- 8	44.5	72.0	95.5	117	137	36.0	72.5	109	145	181
M	2 500	780	0.26	- 18	136	221	293	360	420	118	235	355	470	590
M	2 500	780	0.26	- 18	136	221	293	360	420	118	235	355	470	590
M	3 900	970	0.50	- 23	200	325	430	525	615	181	360	540	720	905
M	2 800	830	0.31	- 20	160	259	345	420	495	142	283	425	565	710
M	3 900	970	0.50	- 23	200	325	430	525	615	181	360	540	720	905
M	3 900	970	0.50	- 23	200	325	430	525	615	181	360	540	720	905
M	5 200	1 120	0.78	- 26	261	425	565	690	805	242	485	725	965	1 210
M	4 280	1 060	0.68	- 24	228	370	490	600	705	210	420	630	840	1 050
M	5 200	1 120	0.78	- 26	261	425	565	690	805	242	485	725	965	1 210
M	8 050	1 400	1.5	- 33	365	595	790	965	1 130	390	775	1 170	1 550	1 940
M	6 400	1 250	1.1	- 29	315	510	680	830	970	305	615	920	1 230	1 530
M	7 230	1 330	1.3	- 31	340	550	735	895	1 050	345	690	1 040	1 380	1 730
M	8 050	1 400	1.5	- 33	365	595	790	965	1 130	390	775	1 170	1 550	1 940
EL	1 230	880	0.15	- 6	505	820	1 090	1 330	1 560	510	1 020	1 530	2 040	2 550
EL	1 230	880	0.15	- 6	505	820	1 090	1 330	1 560	510	1 020	1 530	2 040	2 550
EL	1 620	1 050	0.21	- 7	625	1 020	1 350	1 650	1 930	680	1 360	2 040	2 720	3 400
EL	1 620	1 050	0.21	- 7	625	1 020	1 350	1 650	1 930	680	1 360	2 040	2 720	3 400
EL	1 710	1 130	0.24	- 7	765	1 240	1 650	2 020	2 360	794	1 590	2 380	3 200	3 950
EL	1 710	1 130	0.24	- 7	765	1 240	1 650	2 020	2 360	794	1 590	2 380	3 200	3 950
EL	1 850	1 240	0.27	- 7	870	1 420	1 880	2 300	2 690	1 040	2 080	3 100	4 150	5 200
EL	1 850	1 240	0.27	- 7	870	1 420	1 880	2 300	2 690	1 040	2 080	3 100	4 150	5 200
EL	1 940	1 310	0.30	- 7	1 030	1 670	2 220	2 710	3 150	1 360	2 720	4 100	5 450	6 800
EL	1 940	1 310	0.30	- 7	1 030	1 670	2 220	2 710	3 150	1 360	2 720	4 100	5 450	6 800

B/S Support for High-Load Drive Applications

4. Ball Screw Support Bearings

NSKHPS Angular Contact Thrust Ball Bearings for Ball Screw Support (Double-Row)

The BSBD Series are double-row bearing units for the support of ball screws that can accurately and quickly position a work piece or a spindle unit.



Features

The bearings of this series are double-row angular contact thrust ball bearings with a 60° contact angle and a single outer ring. The specifications are the same as those of the NSKTAC bearings, both series being optimized for the support of ball screws in machine tools. All BSBD Series bearings are equipped with a rubber contact seal and prepacked with high performance grease.

■ BSN Type

The BSN series of ball screw support bearings are double-row angular contact thrust ball bearings in a back-to-back arrangement, with a single outer ring. The bearings are prepacked with high performance grease. Lubrication holes

allow for relubrication during operation if necessary. The contact seal offers minimized friction and temperature rise while providing excellent sealing performance.

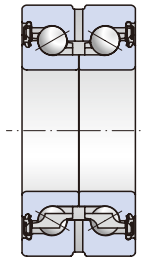

■ BSF Type

The BSF series of bearings is equivalent to the BSN range of bearings, with bolt holes on the outer ring for easy direct mounting. Two lubrication holes – one in the outer surface and one in the face of the outer ring – allow for relubrication during operation if required. If not used, these holes are closed off with set screws. An extraction groove on the outer surface of the outer ring aids removal of the bearing.

Note: BSF series bearings are supplied with seal and set screws included. Mounting bolts are not included.

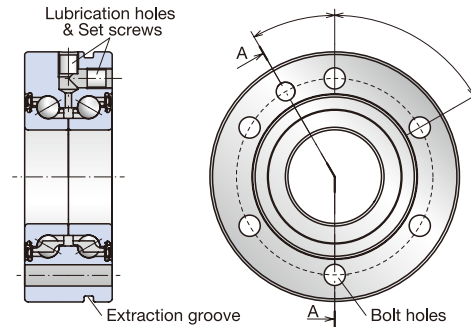

BSN Type Single product

Designation	Boundary Dimensions (mm)					Abutment and Fillet Dimensions (mm)		Contact Angle (°)	Basic Load Ratings (kN)		Limiting static axial load (1) (kN)	Preload (N)	Axial Rigidity (N/μm)	Mass (kg)	Limiting Speeds (min ⁻¹)	Starting Torque (N·m)	Recommended Clamping Force (N)
	d	D	B	r (min.)	r ₁ (min.)	d _a (min.)	D _b (max.)		C _a (Dynamic)	C _{oa} (Static)							
BSN1242	12	42	25	0.6	0.3	15	33	60	22.2	24.0	17.6	720	375	0.20	8 000	0.038	4 030
BSN1545	15	45	25	0.6	0.3	19	35	60	23.3	26.9	19.4	675	400	0.22	7 100	0.034	4 050
BSN1747	17	47	25	0.6	0.6	21	37	60	24.4	29.7	21.2	880	450	0.23	6 700	0.05	4 400
BSN2052	20	52	28	0.6	0.6	24	43	60	31.5	41.0	29.3	1 885	650	0.31	5 800	0.13	7 600
BSN2557	25	57	28	0.6	0.6	29	48	60	34.0	48.0	34.0	2 245	750	0.36	5 100	0.16	8 100
BSN3062	30	62	28	0.6	0.6	34	53	60	36.0	55.5	38.5	2 625	850	0.40	4 500	0.19	8 600
BSN3072	30	72	38	0.6	0.6	35	64	60	72.5	94.0	66.5	4 855	950	0.74	3 900	0.59	11 100
BSN3572	35	72	34	0.6	0.6	40	62	60	50.0	77.5	52.0	2 630	900	0.66	3 800	0.21	13 500
BSN4075	40	75	34	0.6	0.6	46	67	60	53.0	88.0	58.5	3 065	1 000	0.65	3 500	0.24	14 100
BSN4090	40	90	46	0.6	0.6	46	80	60	94.5	135	91.0	7 220	1 200	1.38	3 100	1.02	18 700
BSN5090	50	90	34	0.6	0.6	56	82	60	57.5	110	71.5	4 020	1 250	0.93	2 800	0.33	15 400
BSN50110	50	110	54	0.6	0.6	57	98	60	139	219	149	7 435	1 400	2.46	2 500	1.06	19 100
BSN60110	60	110	45	0.6	0.6	68	100	60	104	187	126	4 780	1 300	1.82	2 400	0.50	20 900

(1) Permissible axial load equals 0.7 times of limiting axial load.
(2) The values indicate starting torque of preloaded bearings, not including seal torque.

Angular Contact Thrust Ball Bearings for Ball Screw Support (Double-Row) (BSBD Series)

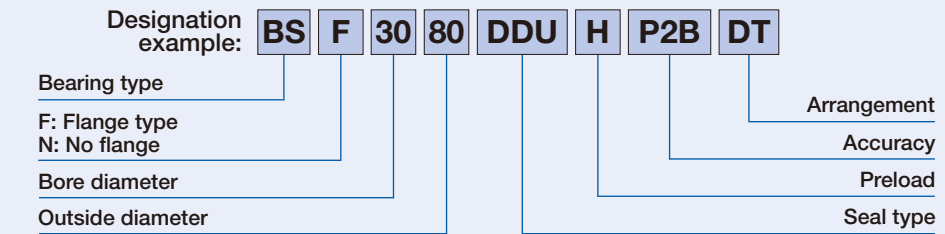

Note: P2B is an accuracy class specific to the BSBD Series, indicating the following:
Running accuracy: ISO Class 2
Others: NSK-specific

■ Seal

Rubber contact seal on both sides. Triple lip structure provides high grease sealing performance and dust resistance.

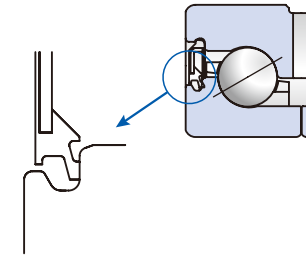

■ Matched DT pairs

BSBD bearings are available in matched DT pairs for applications with large external loads or where high rigidity and long life are required. The mating surfaces of the 2-row bearing set are controlled for offset, so as to have no impact on the preload of each individual bearing.

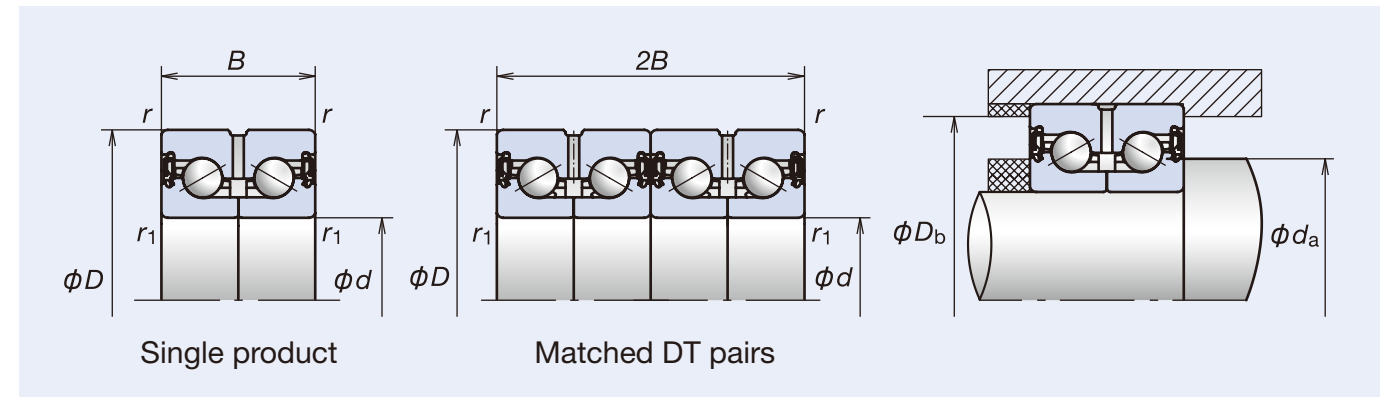
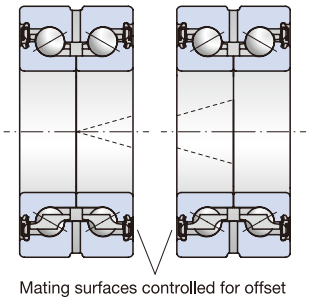

BSN Type Matched DT pairs

Designation	Boundary Dimensions (mm)					Abutment and Fillet Dimensions (mm)		Contact Angle (°)	Basic Load Ratings (kN)		Limiting static axial load (1) (kN)	Axial Rigidity (N/μm)	Mass (kg)	Limiting Speeds (min ⁻¹)	Starting Torque (N·m)	Recommended Clamping Force (N)
	d	D	2B	r (min.)	r ₁ (min.)	d _a (min.)	D _b (max.)		C _a (Dynamic)	C _{oa} (Static)						
BSN1747-DT	17	47	50	0.6	0.6	21	37	60	39.5	59.5	42.5	790	0.46	6 700	0.10	4 400
BSN2052-DT	20	52	56	0.6	0.6	24	43	60	51.5	82.0	58.5	1 180	0.62	5 800	0.26	7 600
BSN2557-DT	25	57	56	0.6	0.6	29	48	60	55.0	96.0	68.0	1 370	0.71	5 100	0.32	8 100
BSN3062-DT	30	62	56	0.6	0.6	34	53	60	58.5	111	77.0	1 580	0.80	4 500	0.37	8 600
BSN3072-DT	30	72	76	0.6	0.6	35	64	60	118	188	133	1 800	1.47	3 900	1.17	11 100
BSN3572-DT	35	72	68	0.6	0.6	40	62	60	81.5	155	104	1 630	1.32	3 800	0.41	13 500
BSN4075-DT	40	75	68	0.6	0.6	46	67	60	86.5	176	117	1 850	1.30	3 500	0.49	14 100
BSN4090-DT	40	90	92	0.6	0.6	46	80	60	153	269	182	2 300	2.76	3 100	2.03	18 700
BSN5090-DT	50	90	68	0.6	0.6	56	82	60	93.5	220	143	2 330	1.86	2 800	0.66	15 400
BSN50110-DT	50	110	108	0.6	0.6	57	98	60	226	440	299	2 690	4.92	2 500	2.11	19 100

(1) Inner rings can be separable easily. Please push or pull bearings by clamping innerring at mounting and dismounting.
(2) Abutment and fillet dimensions are recommendable values for the use of standard Machine tool applications. For heavy load applications, please ask NSK

4. Ball Screw Support Bearings

Double-Row (BSBD Series)

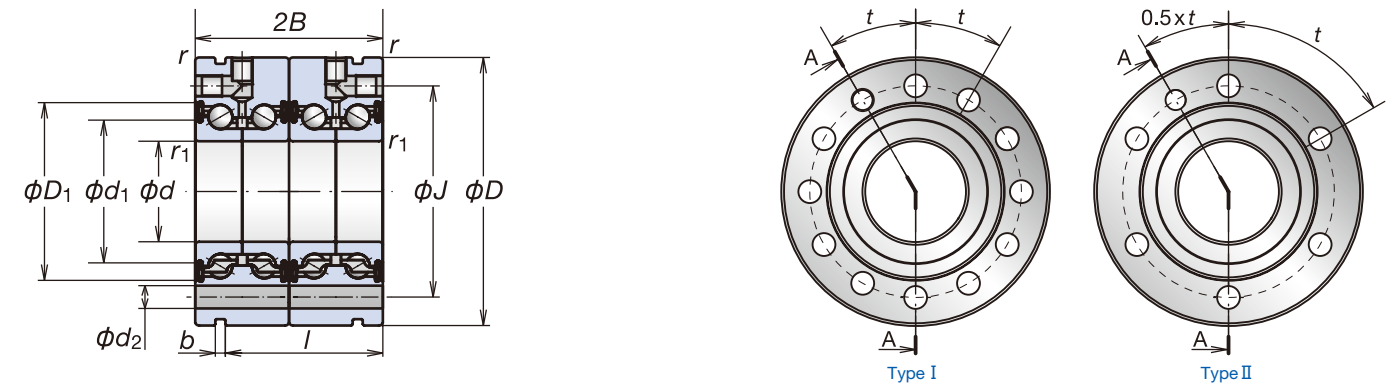
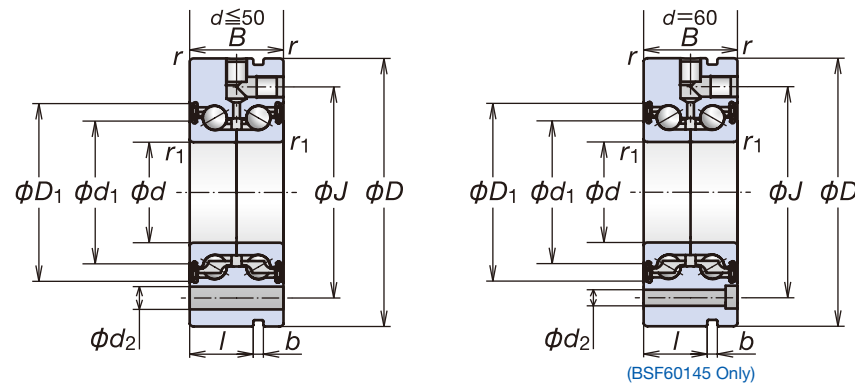

BSF Type Single product

Designation	Boundary Dimensions (mm)					Contact Angle (°)	Basic Load Ratings (kN)		Limiting static axial load (1) (kN)	Axial Rigidity (N/μm)	Mass (kg)	Limiting Speeds (min ⁻¹) Grease
	d	D	B	r (min.)	r ₁ (min.)		C _a (Dynamic)	C _{oa} (Static)				
BSF1255	12	55	25	0.6	0.3	60	22.2	24.0	17.6	375	0.37	8 000
BSF1560	15	60	25	0.6	0.3	60	23.3	26.9	19.4	400	0.44	7 100
BSF1762	17	62	25	0.6	0.6	60	24.4	29.7	21.2	450	0.46	6 700
BSF2068	20	68	28	0.6	0.6	60	31.5	41.0	29.3	650	0.61	5 800
BSF2575	25	75	28	0.6	0.6	60	34.0	48.0	34.0	750	0.73	5 100
BSF3080	30	80	28	0.6	0.6	60	36.0	55.5	38.5	850	0.79	4 500
BSF30100	30	100	38	0.6	0.6	60	72.5	94.0	66.5	950	1.71	3 900
BSF3590	35	90	34	0.6	0.6	60	50.0	77.5	52.0	900	1.20	3 800
BSF40100	40	100	34	0.6	0.6	60	53.0	88.0	58.5	1 000	1.49	3 500
BSF40115	40	115	46	0.6	0.6	60	94.5	135	91.0	1 200	2.56	3 100
BSF50115	50	115	34	0.6	0.6	60	57.5	110	71.5	1 250	1.89	2 800
BSF50140	50	140	54	0.6	0.6	60	139	219	149	1 400	4.46	2 500
BSF60145	60	145	45	0.6	0.6	60	104	187	126	1 300	4.06	2 400

Reference Dimensions (mm)							Type	Mounting Bolts		Preload (N)	Starting Torque (2) (N·m) H	Recommended Clamping Force (N)
d ₁	D ₁	J	d ₂	l	b	t		Bolt Dia.	Number of Bolts			
23.7	32.7	42	6.8	17	3	3 x 120°	II	M6	3	720	0.038	4 030
26.7	35.7	46	6.8	17	3	3 x 120°	II	M6	3	675	0.034	4 050
28.1	37.7	48	6.8	17	3	3 x 120°	II	M6	3	890	0.05	4 400
32.6	43	53	6.8	19	3	4 x 90°	II	M6	4	1 885	0.13	7 600
37.6	48	58	6.8	19	3	4 x 90°	II	M6	4	2 245	0.16	8 100
42.6	53	63	6.8	19	3	6 x 60°	II	M6	6	2 625	0.19	8 600
49.1	64.4	80	8.8	30	3	8 x 45°	II	M8	8	4 855	0.59	11 100
53.1	62.2	75	8.8	25	3	4 x 90°	II	M8	4	2 630	0.21	13 500
55.1	67.2	80	8.8	25	3	4 x 90°	II	M8	4	3 065	0.24	14 100
63.1	80.1	94	8.8	36	3	12 x 30°	II	M8	12	7 220	1.02	18 700
70.1	82.2	94	8.8	25	3	6 x 60°	II	M8	6	4 020	0.33	15 400
78.1	97.5	113	11	45	3	12 x 30°	II	M10	12	7 435	1.06	19 100
83.1	99.3	120	8.8	35	3	8 x 45°	II	M8	8	4 780	0.50	20 900

BSF Type Matched DT pairs

Designation	Boundary Dimensions (mm)					Contact Angle (°)	Basic Load Ratings (kN)		Limiting static axial load (1) (kN)	Axial Rigidity (N/μm)	Mass (kg)	Limiting Speeds (min ⁻¹) Grease
	d	D	2B	r (min.)	r ₁ (min.)		C _a (Dynamic)	C _{oa} (Static)				
BSF1762-DT	17	62	50	0.6	0.6	60	39.5	59.5	42.5	790	0.890	6 700
BSF2068-DT	20	68	56	0.6	0.6	60	51.5	82.0	58.5	1 180	1.17	5 800
BSF2575-DT	25	75	56	0.6	0.6	60	55.0	96.0	68.0	1 370	1.46	5 100
BSF3080-DT	30	80	56	0.6	0.6	60	58.5	111	77.0	1 580	1.58	4 500
BSF30100-DT	30	100	76	0.6	0.6	60	118	188	133	1 800	3.41	3 900
BSF3590-DT	35	90	68	0.6	0.6	60	81.5	155	104	1 630	2.30	3 800
BSF40100-DT	40	100	68	0.6	0.6	60	86.5	176	117	1 850	2.88	3 500
BSF40115-DT	40	115	92	0.6	0.6	60	153	269	182	2 300	5.12	3 100
BSF50115-DT	50	115	68	0.6	0.6	60	93.5	220	143	2 330	3.78	2 800
BSF50140-DT	50	140	108	0.6	0.6	60	226	440	299	2 690	8.92	2 500

Reference Dimensions (mm)							Type	Mounting Bolts		Starting Torque (2) (N·m) H	Recommended Clamping Force (N)
d ₁	D ₁	J	d ₂	l	b	t		Bolt Dia.	Number of Bolts		
28.1	37.7	48	6.8	42	3	6 x 60°	I	M6	5	0.10	4 400
32.6	43	53	6.8	47	3	8 x 45°	I	M6	7	0.26	7 600
37.6	48	58	6.8	47	3	8 x 45°	I	M6	7	0.32	8 100
42.6	53	63	6.8	47	3	12 x 30°	I	M6	11	0.37	8 600
49.1	64.4	80	8.8	68	3	8 x 45°	II	M8	8	1.17	11 100
53.1	62.2	75	8.8	59	3	8 x 45°	I	M8	7	0.41	13 500
55.1	67.2	80	8.8	59	3	8 x 45°	I	M8	7	0.49	14 100
63.1	80.1	94	8.8	82	3	12 x 30°	II	M8	12	2.03	18 700
70.1	82.2	94	8.8	59	3	12 x 30°	I	M8	11	0.66	15 400
78.1	97.5	113	11	99	3	12 x 30°	II	M10	12	2.11	19 100

(1) Permissible axial load equals 0.7 times of limiting axial load.
To calculate permissible axial load, multiply limiting axial load by 0.7. The values refer to the limiting load of the bearing only, without taking the mounting bolts into account.
(2) The values indicate starting torque of preloaded bearings, not including seal torque.
(3) Inner rings can be separable easily. Please push or pull bearings by clamping inner ring at mounting and dismounting.

Double-Row B/S Support

4. Ball Screw Support Bearings

Ball Screw Support Units



This unit for ball screw support in heavy-load and machine tool applications features NSK TAC C Series high-accuracy, high-rigidity angular contact thrust ball bearings. Three types of arrangement are available, as shown below.

Features

- The dust-resistant unit allows the user to easily design the support side of the ball screw.
- Preload-controlled and ready-mounted bearings eliminate the need for on-site mounting of bearings.

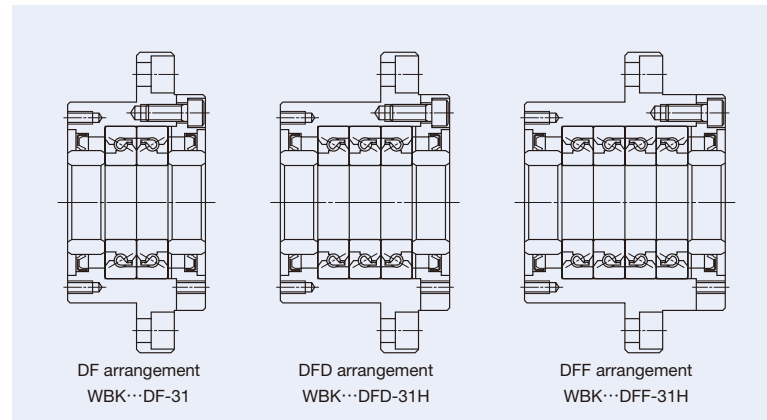
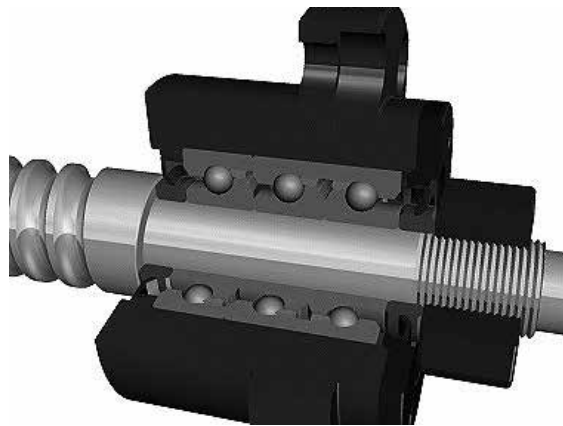

Numbering system of support units

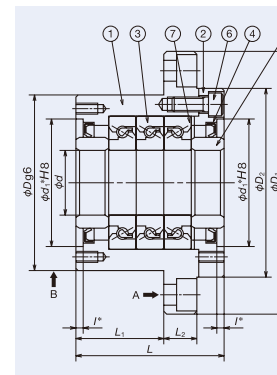
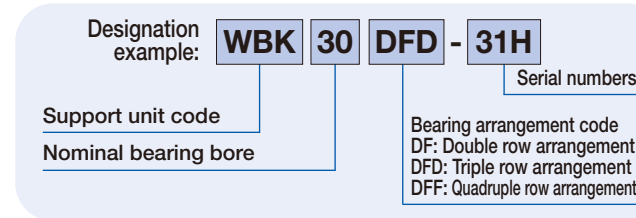

Components of support unit

Part No.	Name of Part	Quantities
①	Housing	1
②	Retaining cover	1
③	Angular contact thrust ball bearings for Ball Screw Support	1 set
④	Dust seal	2
⑤	Collar	2
⑥	Preload securing bolt	6 or 8
⑦	Shim	1 set
⑧	Locknut	1

1. Use datum faces A and B to mount the support unit to a machine base.
2. Do not try to disassemble the NSK Support Unit because its preload is adjusted with high precision and the components ①, ②, ③, ④, ⑥ and ⑦ are integrated into a single piece.
3. The bearings are prepacked with grease.
4. Locknut ⑧ is designed specifically for ball screws with its perpendicularities controlled against the triangular thread of the screw. Tighten the set screws to prevent loosening of the locknut.

The locknut is also available separately. For further information on angular contact thrust ball bearings for ball screw support (NSK TAC C Series), please refer to Page 144.

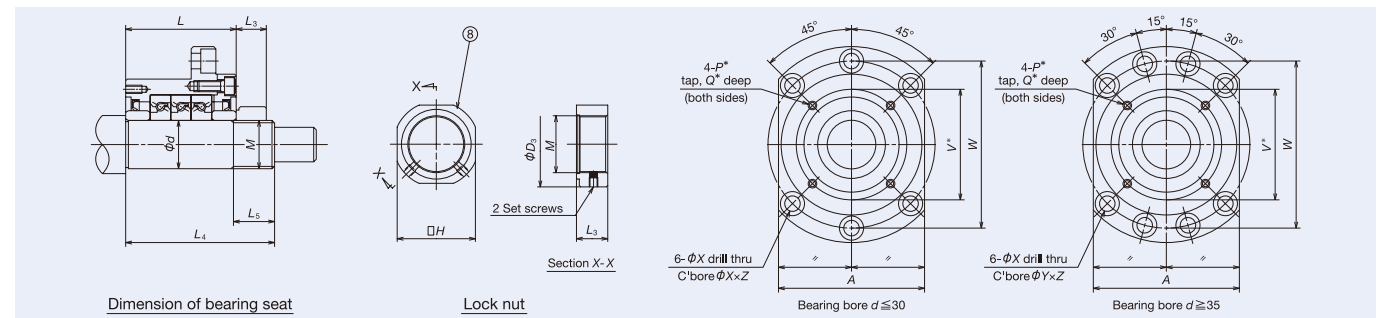

Support Unit Numbers	Support Unit Parts (mm)																
	d	D	D ₁	D ₂	L	L ₁	L ₂	A	W	X	Y	Z	d ₁ *	I*	V*	P*	Q*
WBK17DF-31H	17	70	106	72	60	32	15	80	88	9	14	8.5	45	3	58	M5	10
WBK20DF-31H	20	70	106	72	60	32	15	80	88	9	14	8.5	45	3	58	M5	10
WBK25DF-31H	25	85	130	90	66	33	18	100	110	11	17.5	11	57	4	70	M6	12
WBK25DFD-31H	25	85	130	90	81	48	18	100	110	11	17.5	11	57	4	70	M6	12
WBK30DF-31H	30	85	130	90	66	33	18	100	110	11	17.5	11	57	4	70	M6	12
WBK30DFD-31H	30	85	130	90	81	48	18	100	110	11	17.5	11	57	4	70	M6	12
WBK35DF-31H	35	95	142	102	66	33	18	106	121	11	17.5	11	69	4	80	M6	12
WBK35DFD-31H	35	95	142	102	81	48	18	106	121	11	17.5	11	69	4	80	M6	12
WBK35DFF-31H	35	95	142	102	96	48	18	106	121	11	17.5	11	69	4	80	M6	12
WBK40DF-31H	40	95	142	102	66	33	18	106	121	11	17.5	11	69	4	80	M6	12
WBK40DFD-31H	40	95	142	102	81	48	18	106	121	11	17.5	11	69	4	80	M6	12
WBK40DFF-31H	40	95	142	102	96	48	18	106	121	11	17.5	11	69	4	80	M6	12

(¹) Rigidity: Rigidity values in the table are theoretical values calculated from elastic displacement between grooves and steel balls.
 (²) Starting torque: The values indicate starting torque of preloaded bearings, not including seal torque.
 (³) Tolerance of shaft outside diameter at bearing seat; h5 Class is recommended for the shaft outside diameter at the support unit's bearing seat.

Basic Dynamic Load Rating Ca [kN]	Limiting axial load [kN]	Preload [N]	Axial Rigidity [N/μm]	Starting Torque [N·cm]	Locknut				Bearing seat for unit [mm]			Limiting Speeds [min ⁻¹]	Mass [kg]
					Reference Dimensions [mm]				d	L ₄	L ₅		
					M	H	D ₃	L ₃					
27.6	26.6	1 450	630	14	M17×1.0	32	37	18	17	81	23	6 900	1.9
27.6	26.6	1 450	630	14	M20×1.0	36	40	18	20	81	23	6 900	1.9
36.0	40.5	2 280	850	21	M25×1.5	41	45	20	25	89	26	5 200	3.1
58.5	81.5	3 100	1 250	28	M25×1.5	41	45	20	25	104	26	5 200	3.4
37.0	43.0	2 400	890	23	M30×1.5	46	50	20	30	89	26	4 900	3.0
59.5	86.0	3 260	1 310	30	M30×1.5	46	50	20	30	104	26	4 900	3.3
39.0	50.0	2 750	1 030	27	M35×1.5	50	55	22	35	92	30	4 100	3.4
63.5	100	3 740	1 500	34	M35×1.5	50	55	22	35	107	30	4 100	4.3
63.5	100	5 490	2 060	43	M35×1.5	50	55	22	35	122	30	4 100	5.0
40.0	52.0	2 860	1 080	28	M40×1.5	55	60	22	40	92	30	4 100	3.6
65.0	104	3 900	1 590	36	M40×1.5	55	60	22	40	107	30	4 100	4.2
65.0	104	5 730	2 150	46	M40×1.5	55	60	22	40	122	30	4 100	4.7

(⁴) Dimensions marked with *: The spigot and screw parts marked with * are used for mounting a seal unit for the NSK standard hollow ball screw shaft as well as for mounting a dust cover and damper.
 (⁵) As bearings are prepacked with grease, the unit can be used immediately as is.
 (⁶) To calculate permissible axial load, multiply limiting axial load by 0.7.



Tapered Roller Bearings

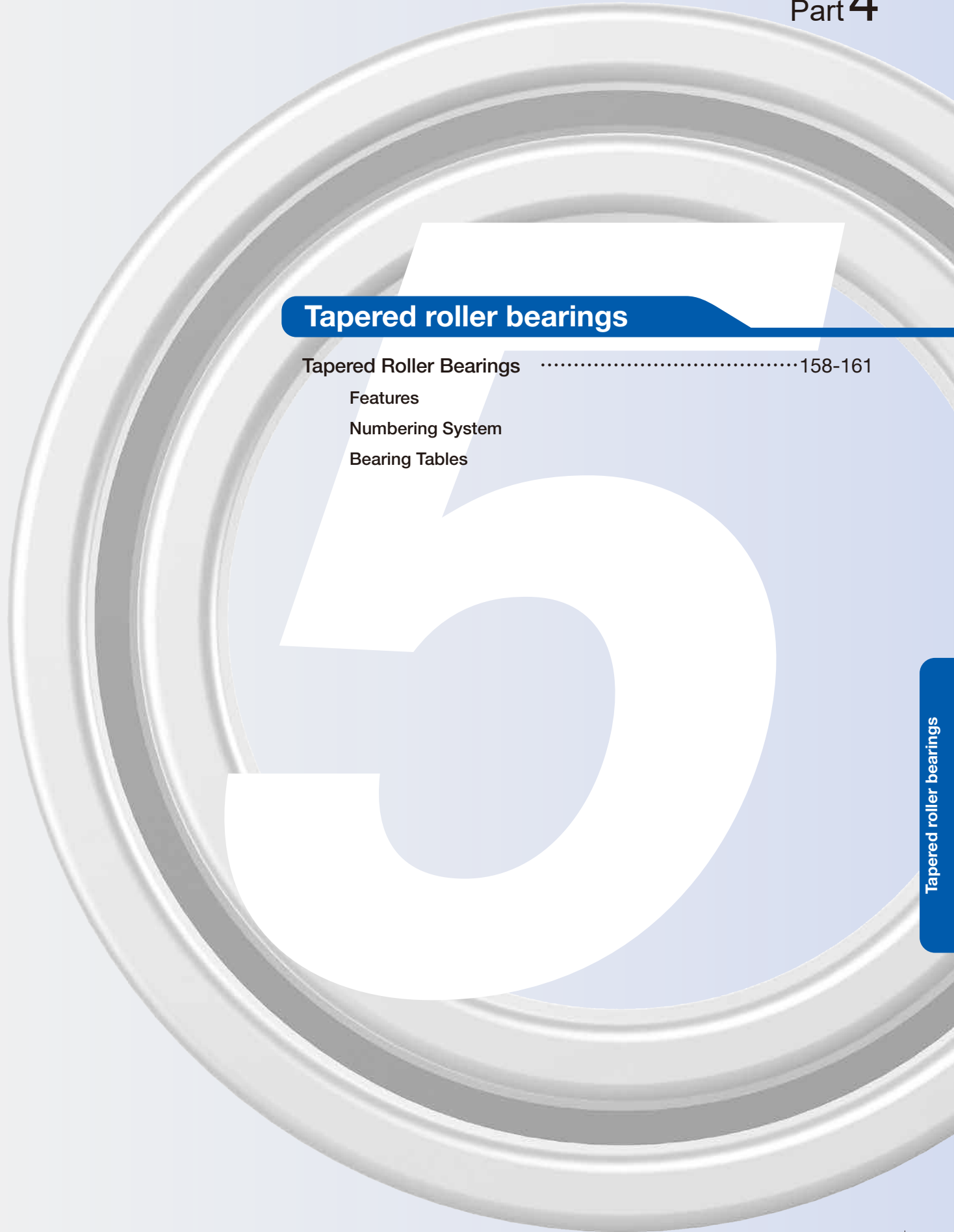

Tapered roller bearings

- Tapered Roller Bearings158-161
 - Features
 - Numbering System
 - Bearing Tables

Tapered roller bearings

Tapered Roller Bearings

Design, Types and Features

Tapered roller bearings are designed so that the apices of the cones formed by the raceways of the cone and cup and the conical rollers all coincide at one point on the central axis of the bearing. When a radial load is imposed, an axial force also occurs; therefore, it is necessary to use two bearings in opposition or some other multiple arrangement.

The suffix J after the basic number of some high load capacity bearings (HR series) indicates that the cup back face raceway diameter, cup width, and contact angle conform to ISO specifications. Therefore, the cone assembly and cup of bearings with the same basic number suffixed with J are internationally interchangeable.

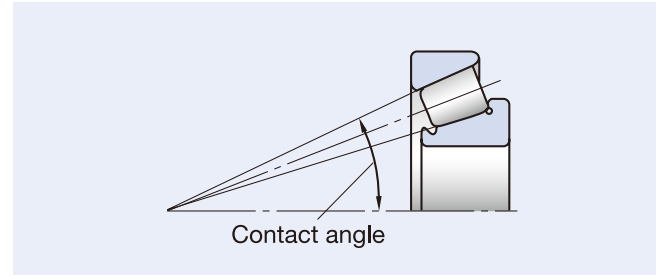

Design and Features of Combinations of Tapered Roller Bearings

Figure	Arrangement	Examples of Bearing No.	Features
	Back-to-back	HR32920JDB+KLR30	Two standard bearings are combined. The bearing clearances are adjusted by cone spacers or cup spacers. The cones, cups and spacers are marked with serial numbers as well as codes for matching. Components with the same serial number need to be assembled with regard to these matching codes.
	Face-to-face	HR32920JDF+KR	

Dimensions Related to Mounting

The dimensions related to mounting tapered roller bearings are listed in the bearing tables. Since the cages protrude from the ring faces of tapered roller bearings, please use care when designing shafts and housings.

When heavy axial loads are imposed, the shaft shoulder dimensions and strength must be sufficient to support the cone rib.

Permissible Misalignment

The permissible misalignment angle for tapered roller bearings is approximately 0.0009 radian (3').

Limiting Speeds

The limiting speeds listed in the bearing tables should be adjusted depending on the bearing load conditions. For more details, please contact NSK.

Numbering System of Tapered Roller Bearings

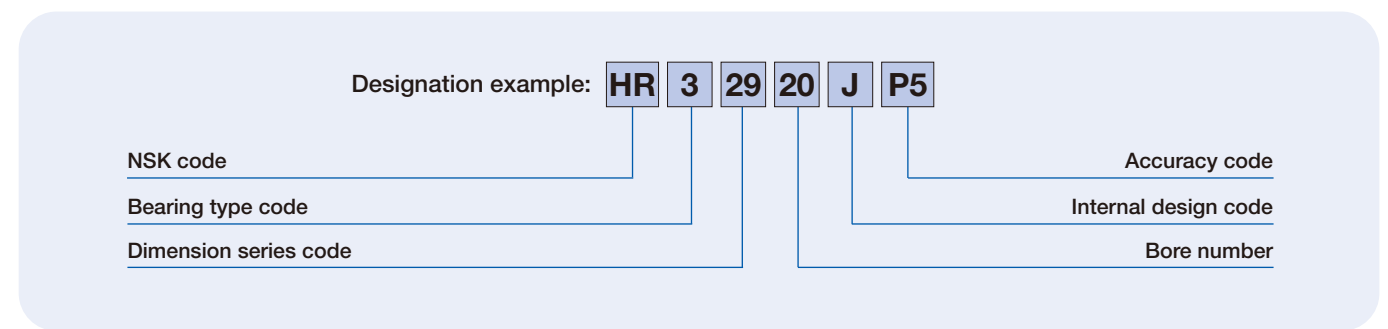

HR	NSK code	HR: High load capacity
3	Bearing type	3: Tapered roller bearing
29	Dimension series	20: 20 Series 29: 29 Series
20	Bore number	Bearing bore = Bore number x5 (mm)
J	Internal design	X: Bearing boundary dimensions conform to ISO specifications (20 Series) J: Cup back face raceway diameter, cup width, and contact angle conform to ISO specifications
P5	Accuracy	P5: ISO Class 5, P4: ISO Class 4

5. Tapered Roller Bearings

Bore Diameter **100-360**mm

Single-Row Tapered Roller Bearings

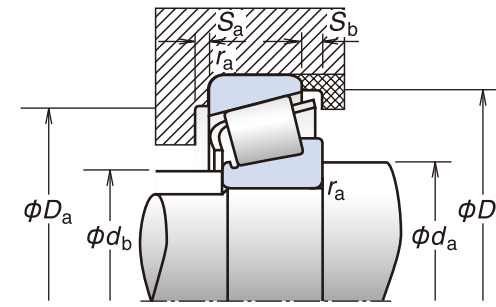
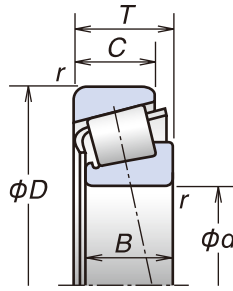

Dynamic Equivalent Load

$$P = XF_r + YF_a$$

$F_a/F_r \leq e$		$F_a/F_r > e$	
X	Y	X	Y
1	0	0.4	Y_1

Static Equivalent Load

$$P_0 = 0.5F_r + Y_0F_a$$

When $F_r > 0.5F_r + Y_0F_a$,

use $P_0 = F_r$

The values of e , Y_1 and Y_0 given in the table below.

Designation	Boundary Dimensions (mm)							Basic Load Ratings (kN)		Effective Load Center (mm) a	Mass (kg) (approx.)	Limiting Speeds (min ⁻¹)	
	d	D	T	B	C	Cone	Cup	C_r (Dynamic)	C_{0r} (Static)			Grease	Oil
						r (min.)							
HR32020XJ	100	150	32	32	24	2	1.5	176	294	32.5	1.95	2 200	3 000
HR32920J	100	140	25	25	20	1.5	1.5	117	205	24.2	1.18	2 200	3 200
HR32021XJ	105	160	35	35	26	2.5	2	204	340	34.3	2.48	2 000	2 800
HR32921J	105	145	25	25	20	1.5	1.5	119	212	25.3	1.23	2 200	3 000
HR32022XJ	110	170	38	38	29	2.5	2	236	390	35.9	3.09	2 000	2 600
HR32922J	110	150	25	25	20	1.5	1.5	123	224	26.5	1.29	2 200	2 800
HR32024XJ	120	180	38	38	29	2.5	2	242	405	39.7	3.27	1 800	2 400
HR32924J	120	165	29	29	23	1.5	1.5	161	291	29.2	1.8	1 900	2 600
HR32026XJ	130	200	45	45	34	2.5	2	320	535	43.9	5.06	1 600	2 200
HR32028XJ	140	210	45	45	34	2.5	2	325	555	46.6	5.32	1 600	2 200
HR32928J	140	190	32	32	25	2	1.5	206	390	33.6	2.64	1 700	2 200
HR32030XJ	150	225	48	48	36	3	2.5	375	650	49.8	6.6	1 400	2 000
HR32032XJ	160	240	51	51	38	3	2.5	425	750	53.0	7.93	1 300	1 800
HR32932J	160	220	38	38	30	2.5	2	296	570	38.7	4.32	1 400	1 900
HR32034XJ	170	260	57	57	43	3	2.5	505	890	56.6	10.6	1 200	1 700
HR32934J	170	230	38	38	30	2.5	2	294	560	41.7	4.44	1 400	1 800
HR32036XJ	180	280	64	64	48	3	2.5	640	1 130	60.4	14.3	1 200	1 600
HR32936J	180	250	45	45	34	2.5	2	350	685	53.9	6.56	1 300	1 700
HR32038XJ	190	290	64	64	48	3	2.5	650	1 170	63.4	14.9	1 100	1 500
HR32938J	190	260	45	45	34	2.5	2	365	715	55.3	6.83	1 200	1 600
HR32040XJ	200	310	70	70	53	3	2.5	760	1 370	67.4	18.9	1 000	1 400
HR32940J	200	280	51	51	39	3	2.5	480	935	54.2	9.65	1 100	1 500
HR32044XJ	220	340	76	76	57	4	3	885	1 610	73.6	24.4	950	1 300
HR32944J	220	300	51	51	39	3	2.5	490	990	59.2	10.3	1 000	1 400
HR32048XJ	240	360	76	76	57	4	3	920	1 730	79.1	26.2	850	1 200
HR32948J	240	320	51	51	39	3	2.5	500	1 040	65.1	11.1	950	1 300
HR32052XJ	260	400	87	87	65	5	4	1 160	2 160	86.3	38.5	800	1 100
HR32952J	260	360	63.5	63.5	48	3	2.5	730	1 450	69.8	18.6	850	1 100
HR32056XJ	280	420	87	87	65	5	4	1 180	2 240	91.6	40.6	710	1 000
HR32956J	280	380	63.5	63.5	48	3	2.5	765	1 580	75.3	20	800	1 100
HR32060XJ	300	460	100	100	74	5	4	1 440	2 700	98.4	56.6	670	900
HR32960J	300	420	76	76	57	4	3	1 010	2 100	79.9	31.4	710	950
HR32064XJ	320	480	100	100	74	5	4	1 510	2 910	104.5	60	630	850
HR32972J	360	480	76	76	57	4	3	1 080	2 340	96.8	36.1	560	800

Constant e	Axial Load Factors		Abutment and Fillet Dimensions (mm)								
			d_a (min.)	d_b (max.)	D_a		D_b (min.)	S_a (min.)	S_b (min.)	Cone r_a (max.)	Cup r_a (max.)
	Y_1	Y_0	(max.)	(min.)	(min.)	(min.)	(min.)	(min.)	(max.)	(max.)	
0.46	1.3	0.72	112	109	141	136	144	6	8	2	1.5
0.33	1.8	1.0	111	109	132	132	134	5	5	1.5	1.5
0.44	1.4	0.74	120	115	150	144	154	6	9	2	2
0.34	1.8	0.96	116	114	137	137	140	5	5	1.5	1.5
0.43	1.4	0.77	125	121	160	153	163	7	9	2	2
0.36	1.7	0.93	121	119	142	142	145	5	5	1.5	1.5
0.46	1.3	0.72	135	131	170	162	173	7	9	2	2
0.35	1.7	0.95	131	129	156	155	160	6	6	1.5	1.5
0.43	1.4	0.76	145	144	190	179	192	8	11	2	2
0.46	1.3	0.72	155	152	200	189	202	8	11	2	2
0.36	1.7	0.92	152	150	180	178	184	6	7	2	1.5
0.46	1.3	0.72	168	164	213	202	216	8	12	2.5	2
0.46	1.3	0.72	178	175	228	216	231	8	13	2.5	2
0.35	1.7	0.95	175	173	208	206	212	7	8	2	2
0.44	1.4	0.74	188	187	248	232	249	10	14	2.5	2
0.38	1.6	0.86	185	180	218	215	222	7	8	2	2
0.42	1.4	0.78	198	199	268	248	267	10	16	2.5	2
0.48	1.3	0.69	195	192	240	227	241	8	11	2	2
0.44	1.4	0.75	208	209	278	258	279	10	16	2.5	2
0.48	1.3	0.69	205	201	250	237	251	8	11	2	2
0.43	1.4	0.77	218	221	298	277	297	11	17	2.5	2
0.39	1.5	0.84	218	216	268	258	271	9	12	2.5	2
0.43	1.4	0.77	241	244	326	303	326	12	19	3	2.5
0.43	1.4	0.78	238	235	288	278	293	9	12	2.5	2
0.46	1.3	0.72	261	262	346	321	346	12	19	3	2.5
0.46	1.3	0.72	258	255	308	297	314	9	12	2.5	2
0.43	1.4	0.76	287	287	382	357	383	14	22	4	3
0.41	1.5	0.81	278	278	348	333	347	11	15.5	2.5	2
0.46	1.3	0.72	307	305	402	374	402	14	22	4	3
0.43	1.4	0.76	298	297	368	352	368	12	15.5	2.5	2
0.43	1.4	0.76	327	330	442	408	439	15	26	4	3
0.39	1.5	0.84	321	324	406	387	405	13	19	3	2.5
0.46	1.3	0.72	347	350	462	430	461	15	26	4	3
0.46	1.3	0.72	381	381	466	445	466	13	19	3	2.5

Tapered roller bearings



Single-Direction Thrust Ball Bearings

Thrust Cylindrical Roller Bearings



ROBUSTSLIM

Thrust Bearings

Thrust Bearings164-175

Features

Numbering System

Bearing Tables

Single-Direction Thrust Ball Bearings

Thrust Cylindrical Roller Bearings

ROBUSTSLIM

Thrust Bearings

Thrust Bearings

Types and Features

Single-Direction Thrust Ball Bearings

Thrust ball bearings can sustain axial loads but no radial loads.

For single-direction thrust ball bearings, pressed steel cages and machined brass cages are usually used as shown in Table 6.1.

The basic load ratings listed in the bearing tables are based on the standard cage type shown in Table 6.1.

For identical designation, different cage types may imply a different number of balls; in such a case, the load rating will differ from the one listed in the bearing tables.

Table 6.1 Standard Cages for Thrust Ball Bearings

	Flat seat	Pressed steel cage	Machined brass cage
Single-direction	511	51106-51152X	51156X-51180X
	512	51206-51236X	51238X-51280X
	513	51306-51336X	51338X-51340X
	514	51406-51418X	51420X-51436X

Thrust Cylindrical Roller Bearings

These are thrust bearings containing cylindrical rollers. They can sustain only axial loads, but they are suitable for heavy loads and have high axial rigidity.

The cages are machined brass.

Minimum Axial Load

It is necessary to apply some axial load to thrust bearings to prevent slippage between the rolling elements and the raceways. For more details please refer to page 215.

Numbering System of Single-Direction Thrust Ball Bearings

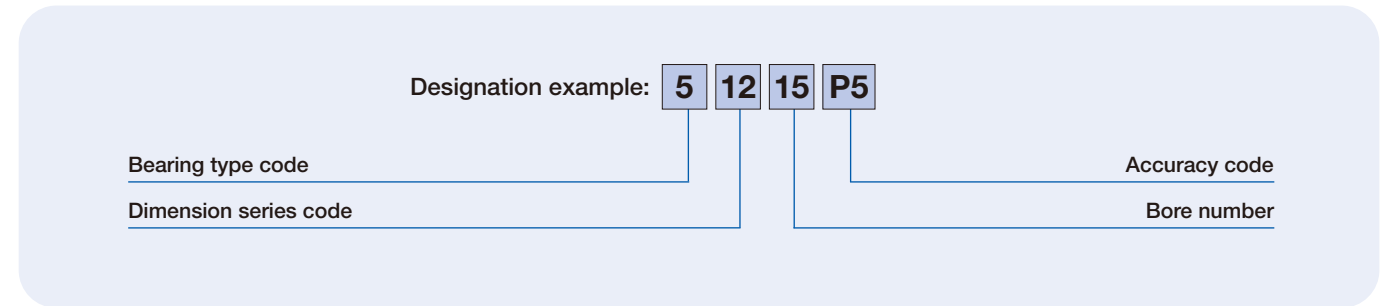

- 5** — Bearing type: 5: Thrust ball bearing
- 12** — Dimension series: 11: 11 Series 12: 12 Series 13: 13 Series 14: 14 Series
- 15** — Bore number: Bearing bore = Bore number × 5 (mm)
- P5** — Accuracy: P5: ISO Class 5, P4: ISO Class 4

Numbering System of Thrust Cylindrical Roller Bearings

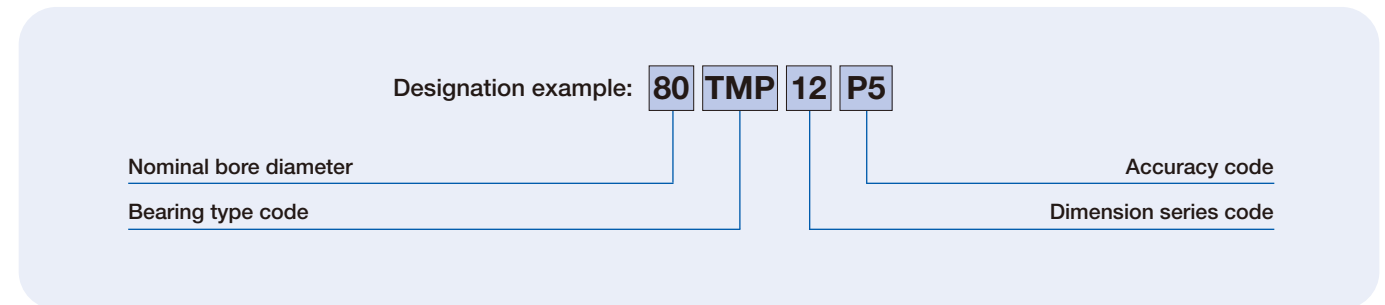

- 80** — Nominal bore diameter: Bore diameter (mm)
- TMP** — Bearing type: TMP: Thrust cylindrical roller bearing
- 12** — Dimension series: 11: 11 Series 12: 12 Series 93: 93 Series
- P5** — Accuracy: P5: Class 5, P4: Class 4

6. Thrust Bearings

Bore Diameter **30-160**mm

Single-Direction Thrust Ball Bearings

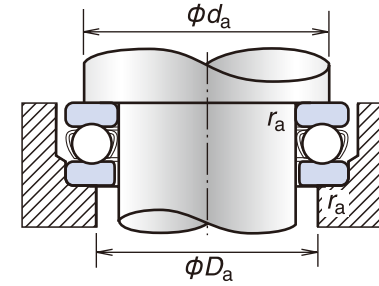
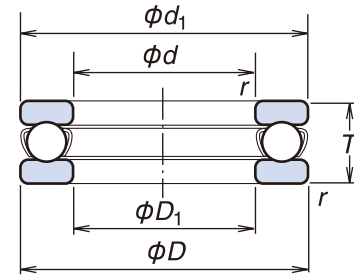

Designation	Boundary Dimensions (mm)						Basic Load Ratings (kN)		Mass (kg) (approx.)	Limiting Speeds (min ⁻¹)		Minimum Load Factor (°) M (x10 ⁻⁶)	Abutment and Fillet Dimensions (°) (mm)		
	d	D	T	d ₁	D ₁	r (min.)	C _a (Dynamic)	C _{0a} (Static)		Grease	Oil		d _a (min.)	D _a (max.)	r _a (max.)
51106	30	47	11	47	32	0.6	20.6	42	0.064	4 300	6 700	0.009	40	37	0.6
51206	30	52	16	52	32	0.6	29.5	58	0.137	3 400	5 300	0.018	43	39	0.6
51306	30	60	21	60	32	1	43	78.5	0.267	2 800	4 300	0.033	48	42	1
51406	30	70	28	70	32	1	73	126	0.519	2 200	3 400	0.082	54	46	1
51107	35	52	12	52	37	0.6	22.1	49.5	0.081	4 000	6 000	0.013	45	42	0.6
51207	35	62	18	62	37	1	39.5	78	0.210	3 000	4 500	0.033	51	46	1
51307	35	68	24	68	37	1	56	105	0.386	2 400	3 800	0.059	55	48	1
51407	35	80	32	80	37	1.1	87.5	155	0.769	2 000	3 000	0.13	62	53	1
51108	40	60	13	60	42	0.6	27.1	63	0.120	3 600	5 300	0.021	52	48	0.6
51208	40	68	19	68	42	1	47.5	98.5	0.270	2 800	4 300	0.050	57	51	1
51308	40	78	26	78	42	1	70	135	0.536	2 200	3 400	0.098	63	55	1
51209	45	73	20	73	47	1	48	105	0.310	2 600	4 000	0.059	62	56	1
51309	45	85	28	85	47	1	80.5	163	0.672	2 000	3 000	0.14	69	61	1
51110	50	70	14	70	52	0.6	29	75.5	0.153	3 200	4 800	0.030	62	58	0.6
51210	50	78	22	78	52	1	49	111	0.378	2 400	3 600	0.067	67	61	1
51310	50	95	31	95	52	1.1	97.5	202	0.931	1 800	2 800	0.21	77	68	1
51410	50	110	43	110	52	1.5	147	288	1.94	1 400	2 200	0.44	86	74	1.5
51111	55	78	16	78	57	0.6	35	93	0.227	2 800	4 300	0.045	69	64	0.6
51211	55	90	25	90	57	1	70	159	0.599	2 200	3 200	0.13	76	69	1
51311	55	105	35	105	57	1.1	115	244	1.31	1 600	2 400	0.31	85	75	1
51112	60	85	17	85	62	1	41.5	113	0.281	2 600	4 000	0.065	75	70	1
51212	60	95	26	95	62	1	71.5	169	0.673	2 000	3 000	0.15	81	74	1
51312	60	110	35	110	62	1.1	119	263	1.40	1 600	2 400	0.36	90	80	1
51113	65	90	18	90	67	1	42	117	0.324	2 400	3 800	0.073	80	75	1
51213	65	100	27	100	67	1	75.5	189	0.756	1 900	2 800	0.18	86	79	1
51313	65	115	36	115	67	1.1	123	282	1.54	1 500	2 400	0.41	95	85	1
51413	65	140	56	140	68	2	234	495	4.10	1 100	1 700	1.2	110	95	2
51214	70	105	27	105	72	1	74	189	0.793	1 900	2 800	0.19	91	84	1
51314	70	125	40	125	72	1.1	137	315	2.00	1 400	2 000	0.53	103	92	1
51115	75	100	19	100	77	1	43.5	131	0.389	2 200	3 400	0.092	90	85	1
51215	75	110	27	110	77	1	78	209	0.845	1 800	2 800	0.22	96	89	1
51415	75	160	65	160	78	2	254	560	6.15	950	1 400	1.8	125	110	2

Designation	Boundary Dimensions (mm)						Basic Load Ratings (kN)		Mass (kg) (approx.)	Limiting Speeds (min ⁻¹)		Minimum Load Factor (°) M (x10 ⁻⁶)	Abutment and Fillet Dimensions (°) (mm)		
	d	D	T	d ₁	D ₁	r (min.)	C _a (Dynamic)	C _{0a} (Static)		Grease	Oil		d _a (min.)	D _a (max.)	r _a (max.)
51116	80	105	19	105	82	1	45	141	0.417	2 200	3 400	0.10	95	90	1
51216	80	115	28	115	82	1	79	218	0.931	1 800	2 600	0.25	101	94	1
51316	80	140	44	140	82	1.5	164	395	2.74	1 300	1 900	0.82	116	104	1.5
51416	80	170	68	170	83	2.1	272	620	7.21	900	1 300	2.3	133	117	2
51117	85	110	19	110	87	1	46.5	150	0.440	2 200	3 200	0.12	100	95	1
51217	85	125	31	125	88	1	96	264	1.22	1 600	2 400	0.36	109	101	1
51118	90	120	22	120	92	1	60	190	0.646	1 900	3 000	0.19	108	102	1
51218	90	135	35	135	93	1.1	114	310	1.69	1 400	2 200	0.51	117	108	1
51318	90	155	50	155	93	1.5	214	525	3.83	1 100	1 700	1.4	129	116	1.5
51120	100	135	25	135	102	1	86	268	0.960	1 700	2 600	0.37	121	114	1
51220	100	150	38	150	103	1.1	135	375	2.25	1 300	2 000	0.75	130	120	1
51320	100	170	55	170	103	1.5	239	595	4.98	1 000	1 500	1.9	142	128	1.5
51420X	100	210	85	205	103	3	370	985	14.8	710	1 100	5.3	165	145	2.5
51122	110	145	25	145	112	1	88	288	1.04	1 700	2 400	0.43	131	124	1
51222	110	160	38	160	113	1.1	136	395	2.42	1 300	1 900	0.85	140	130	1
51322X	110	190	63	187	113	2	282	755	7.19	900	1 300	3.0	158	142	2
51124	120	155	25	155	122	1	90	310	1.12	1 600	2 400	0.49	141	134	1
51224	120	170	39	170	123	1.1	141	430	2.70	1 200	1 800	1.0	150	140	1
51424X	120	250	102	245	123	4	480	1 400	26.2	600	900	11	196	174	3
51126	130	170	30	170	132	1	105	350	1.68	1 400	2 000	0.69	154	146	1
51226X	130	190	45	187	133	1.5	183	550	3.95	1 100	1 600	1.7	166	154	1.5
51326X	130	225	75	220	134	2.1	350	1 030	12.1	750	1 100	5.6	186	169	2
51128X	140	180	31	178	142	1	107	375	1.83	1 300	2 000	0.79	164	156	1
51228X	140	200	46	197	143	1.5	186	575	4.30	1 000	1 500	1.9	176	164	1.5
51328X	140	240	80	235	144	2.1	370	1 130	14.2	670	1 000	6.8	199	181	2
51130X	150	190	31	188	152	1	110	400	1.95	1 300	1 900	0.89	174	166	1
51230X	150	215	50	212	153	1.5	238	735	5.52	950	1 400	2.9	189	176	1.5
51330X	150	250	80	245	154	2.1	380	1 200	15.0	670	1 000	7.7	209	191	2
51430X	150	300	120	295	154	4	620	2 010	43.5	480	710	24	238	212	3
51132X	160	200	31	198	162	1	113	425	2.07	1 200	1 900	1.0	184	176	1
51332X	160	270	87	265	164	3	475	1 570	19.6	600	900	13	225	205	2.5
51432X	160	320	130	315	164	5	650	2 210	52.7	450	670	28	254	226	4

(¹) For more information on minimum load factors, please refer to page 215.

(²) Designation suffixed with X indicate that the outside diameter d₁ of the shaft washer is smaller than the outside diameter D of the housing washer.

6. Thrust Bearings

Bore Diameter **170-1 700mm**

Single-Direction Thrust Ball Bearings

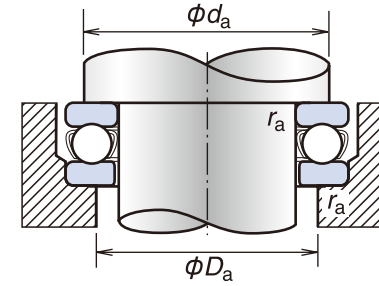
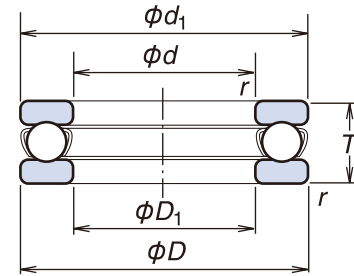

Designation	Boundary Dimensions (mm)						Basic Load Ratings (kN)		Mass (kg) (approx.)	Limiting Speeds (min ⁻¹)		Minimum Load Factor (°) M (x10 ⁻⁶)	Abutment and Fillet Dimensions (°) (mm)		
	d	D	T	d ₁	D ₁	r (min.)	C _a (Dynamic)	C _{0a} (Static)		Grease	Oil		d _a (min.)	D _a (max.)	r _a (max.)
51134X	170	215	34	213	172	1.1	135	510	2.72	1 100	1 700	1.4	197	188	1
51234X	170	240	55	237	173	1.5	280	915	7.41	850	1 300	4.4	212	198	1.5
51136X	180	225	34	222	183	1.1	136	530	2.79	1 100	1 700	1.6	207	198	1
51236X	180	250	56	247	183	1.5	284	955	7.94	800	1 200	4.8	222	208	1.5
51336X	180	300	95	295	184	3	480	1 680	25.9	560	850	15	251	229	2.5
51138X	190	240	37	237	193	1.1	172	655	3.60	1 000	1 600	2.4	220	210	1
51238X	190	270	62	267	194	2	320	1 110	11.8	750	1 100	6.7	238	222	2
51140X	200	250	37	247	203	1.1	173	675	3.75	1 000	1 500	2.5	230	220	1
51240X	200	280	62	277	204	2	315	1 110	12.3	710	1 100	6.9	248	232	2
51144X	220	270	37	267	223	1.1	179	740	4.09	950	1 500	3.0	250	240	1
51244X	220	300	63	297	224	2	325	1 210	13.6	670	1 000	8.2	268	252	2
51148X	240	300	45	297	243	1.5	229	935	6.55	850	1 200	4.9	276	264	1.5
51248X	240	340	78	335	244	2.1	420	1 650	23.7	560	850	15	299	281	2
51448X	240	440	160	435	245	6	915	3 900	115	320	500	85	359	321	5
51152X	260	320	45	317	263	1.5	233	990	7.01	800	1 200	5.6	296	284	1.5
51252X	260	360	79	355	264	2.1	435	1 800	25.1	560	850	18	319	301	2
51156X	280	350	53	347	283	1.5	315	1 310	12.0	710	1 000	9.6	322	308	1.5
51256X	280	380	80	375	284	2.1	450	1 950	27.1	530	800	21	339	321	2
51160X	300	380	62	376	304	2	360	1 560	17.2	600	900	14	348	332	2
51360	300	480	140	480	305	5	860	3 950	103	340	500	90	407	375	4
51164X	320	400	63	396	324	2	365	1 660	18.6	600	900	16	368	352	2
51264X	320	440	95	435	325	3	585	2 680	45.0	450	670	41	391	369	2.5
51364	320	500	140	500	325	5	880	4 200	109	340	500	101	427	395	4
51168X	340	420	64	416	344	2	375	1 760	19.9	560	850	18	388	372	2
51268X	340	460	96	455	345	3	595	2 800	47.9	430	630	46	411	389	2.5
51172X	360	440	65	436	364	2	385	1 860	21.5	560	800	19	408	392	2
51272X	360	500	110	495	365	4	705	3 500	68.8	380	560	70	442	418	3
51176X	380	460	65	456	384	2	385	1 910	22.4	540	800	21	427	413	2
51276	380	520	112	520	385	4	740	3 800	74.5	370	550	80	464	438	3
51180X	400	480	65	476	404	2	395	2 010	23.5	—	790	23	447	433	2
51280X	400	540	112	535	405	4	730	3 800	76.6	—	540	83	484	458	3

Designation	Boundary Dimensions (mm)						Basic Load Ratings (kN)		Mass (kg) (approx.)	Limiting Speeds (min ⁻¹)		Minimum Load Factor (°) M (x10 ⁻⁶)	Abutment and Fillet Dimensions (°) (mm)		
	d	D	T	d ₁	D ₁	r (min.)	C _a (Dynamic)	C _{0a} (Static)		Grease	Oil		d _a (min.)	D _a (max.)	r _a (max.)
51184X	420	500	65	495	424	2	400	2 110	24.4	—	770	25	467	453	2
51284	420	580	130	580	425	5	850	4 650	109	—	470	121	517	485	4
51188X	440	540	80	535	444	2.1	515	2 850	40.5	—	650	45	498	482	2
51288	440	600	130	600	445	5	865	4 850	115	—	460	131	537	505	4
51192X	460	560	80	555	464	2.1	520	2 930	42.0	—	640	48	518	502	2
51292	460	620	130	620	465	5	880	5 050	119	—	460	142	557	525	4
51392	460	710	195	710	465	6	1 200	7 150	291	—	330	292	606	566	5
51196X	480	580	80	575	484	2.1	530	3 100	43.7	—	630	52	538	522	2
51296	480	650	135	650	485	5	890	5 250	137	—	430	155	582	550	4
511/500X	500	600	80	595	504	2.1	560	3 300	45.4	—	620	60	554	546	2
511/530X	530	640	85	635	534	3	640	3 900	56.7	—	570	86	597	575	2.5
512/530	530	710	140	710	535	5	1 010	6 200	165	—	400	224	637	605	4
511/560X	560	670	85	665	564	3	655	4 100	59.6	—	560	95	625	605	2.5
512/560	560	750	150	750	565	5	1 200	7 800	200	—	370	328	672	640	4
511/600X	600	710	85	705	605	3	675	4 400	63.3	—	540	109	665	645	2.5
511/630X	630	750	95	745	634	3	685	4 600	83.0	—	490	120	700	680	2.5
511/670X	670	800	105	795	675	4	760	5 350	104	—	440	160	742	728	3
511/750	750	900	120	900	755	4	910	6 850	156	—	380	262	834	818	3
F980-1	980	1 120	120	1 115	985	5	1 010	8 900	186	—	330	435	1 059	1 041	4
F1250-1	1 250	1 495	150	1 490	1 256	6	1 670	17 200	505	—	240	1 645	1 384	1 362	5
F1400-7	1 400	1 570	100	1 570	1 404	4	1 090	11 800	246	—	300	813	1 494	1 478	3
F1700-2	1 700	1 960	170	1 950	1 710	6	2 210	27 200	783	—	180	4 061	1 838	1 822	5

(¹) For more information on minimum load factors, please refer to page 215.

(²) Designation suffixed with X indicate that the outside diameter d₁ of the shaft washer is smaller than the outside diameter D of the housing washer.

6. Thrust Bearings

Bore Diameter **40-500 mm**

Thrust Cylindrical Roller Bearings

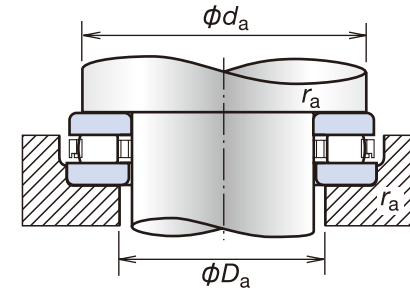
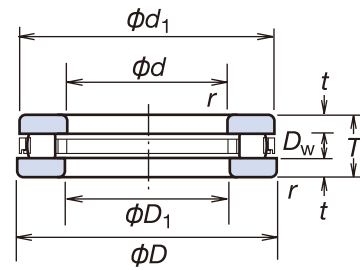

Designation	Boundary Dimensions (mm)				Reference Dimensions (mm)				Basic Load Ratings (kN)		Mass (kg) (approx.)	Limiting Speeds (min ⁻¹)		Minimum Load Factor (*) M (x10 ⁻⁶)	Abutment and Fillet Dimensions (mm)		
	d	D	T	r (min.)	d ₁	D ₁	D _w	t	C _a (Dynamic)	C _{oa} (Static)		Grease	Oil		d _a (min.)	D _a (max.)	r _a (max.)
40TMP93	40	78	22	1	78	42	8	7	63	194	0.525	1 200	3 600	0.0026	71	48	1
45TMP93	45	85	24	1	85	47	8	8	71	233	0.665	1 100	3 400	0.0038	78	53	1
50TMP93	50	95	27	1.1	93	52	11	8	113	350	0.942	1 000	3 000	0.0086	89	57	1
55TMP93	55	105	30	1.1	105	55.2	11	9.5	134	450	1.28	900	2 600	0.014	98	63	1
60TMP12	60	95	26	1	95	62	10	8	99	325	0.735	1 000	3 000	0.0095	88	67	1
60TMP93	60	110	30	1.1	110	62	11	9.5	139	480	1.36	850	2 600	0.016	103	68	1
65TMP12	65	100	27	1	100	67	12.5	7.25	110	325	0.805	950	2 800	0.0095	93	71	1
65TMP93	65	115	30	1.1	115	65.2	11	9.5	145	515	1.44	850	2 600	0.019	108	73	1
70TMP93	70	125	34	1.1	125	72	14	10	191	635	1.95	750	2 200	0.028	117	78	1
75TMP11	75	100	19	1	100	77	8	5.5	63.5	221	0.41	1 100	3 400	0.0068	96	79	1
75TMP93	75	135	36	1.5	135	77	14	11	209	735	2.42	710	2 200	0.038	125	84	1.5
80TMP12	80	115	28	1	115	82	11	8.5	120	420	1.02	900	2 600	0.016	109	86	1
80TMP93	80	140	36	1.5	138	82	14	11	208	740	2.54	710	2 000	0.038	130	91	1.5
85TMP11	85	110	19	1	110	87	7.5	5.75	75	298	0.46	1 100	3 200	0.012	105	89	1
85TMP12	85	125	31	1	125	88	14	8.5	151	485	1.36	800	2 400	0.021	118	92	1
85TMP93	85	150	39	1.5	148	87	14	12.5	257	995	3.2	630	1 900	0.069	140	95	1.5
90TMP11	90	120	22	1	119	91.5	9	6.5	96	370	0.725	950	3 000	0.019	114	95	1
90TMP93	90	155	39	1.5	155	90.2	16	11.5	250	885	3.3	630	1 900	0.055	144	101	1.5
100TMP93	100	170	42	1.5	170	103	16	13	292	1 110	4.25	560	1 700	0.086	159	110	1.5
110TMP12	110	160	38	1.1	160	113	15	11.5	228	855	2.66	630	1 900	0.066	150	119	1
120TMP12	120	170	39	1.1	170	123	15	12	233	895	2.93	600	1 800	0.072	160	129	1
130TMP12	130	190	45	1.5	187	133	19	13	300	1 090	4.5	530	1 600	0.11	177	142	1.5
130TMP93	130	225	58	2.1	225	133	22	18	585	2 370	10.4	430	1 300	0.39	214	140	2
140TMP93	140	240	60	2.1	240	143	25	17.5	610	2 360	12.2	400	1 200	0.39	226	154	2
150TMP12	150	215	50	2	215	153	19	15.5	375	1 500	6.15	480	1 400	0.20	202	163	2
150TMP93	150	250	60	2.1	250	153	25	17.5	635	2 510	12.8	400	1 200	0.44	236	165	2

(*) For more information on minimum load factors, please refer to page 215.

Designation	Boundary Dimensions (mm)				Reference Dimensions (mm)				Basic Load Ratings (kN)		Mass (kg) (approx.)	Limiting Speeds (min ⁻¹)		Minimum Load Factor (*) M (x10 ⁻⁶)	Abutment and Fillet Dimensions (mm)		
	d	D	T	r (min.)	d ₁	D ₁	D _w	t	C _a (Dynamic)	C _{oa} (Static)		Grease	Oil		d _a (min.)	D _a (max.)	r _a (max.)
160TMP11	160	200	31	1	200	162	11	10	173	815	2.21	630	1 900	0.093	191	168	1
170TMP12	170	240	55	1.5	237	173	22	16.5	485	1 960	8.2	430	1 300	0.35	227	182	1.5
180TMP93	180	300	73	3	300	185	32	20.5	1 000	4 000	22.5	320	950	1.1	284	194	2.5
190TMP12	190	270	62	3	266	195	30	16	705	2 630	11.8	360	1 100	0.62	255	200	2.5
190TMP93	190	320	78	4	320	195	32	23	1 080	4 500	27.6	300	900	1.42	303	205	3
200TMP11	200	250	37	1.1	247	203	17	10	365	1 690	4.1	500	1 500	0.40	242	207	1
200TMP93	200	340	85	4	340	205	32	26.5	1 180	5 150	34.5	280	800	1.9	322	218	3
220TMP11	220	270	37	1.1	267	223	17	10	385	1 860	4.5	480	1 500	0.48	262	227	1
220TMP12	220	300	63	2	297	224	30	16.5	770	3 100	13.5	340	1 000	0.86	287	232	2
240TMP11	240	300	45	1.5	297	243	18	13.5	435	2 160	7.2	400	1 200	0.65	288	251	1.5
240TMP12	240	340	78	2.1	335	244	32	23	965	4 100	23.3	280	850	1.5	322	258	2
240TMP93	240	380	85	4	380	245	32	26.5	1 290	6 100	39.4	260	770	2.6	362	258	3
260TMP11	260	320	45	1.5	317	263	18	13.5	460	2 350	7.75	400	1 200	0.77	308	272	1.5
260TMP12	260	360	79	2.1	355	264	32	23.5	995	4 350	25.2	280	850	1.7	342	276	2
260TMP93	260	420	95	1.1	420	265	38	28.5	1 670	7 700	55.2	230	680	4.2	398	282	1
280TMP11	280	350	53	1.5	347	283	20	16.5	545	2 800	11.6	340	1 000	1.1	335	294	1.5
280TMP12	280	380	80	2.1	375	284	32	24	1 050	4 750	27.2	260	800	2.0	362	296	2
300TMP12	300	420	95	3	415	304	38	28.5	1 390	6 250	42	220	670	3.5	398	322	2.5
320TMP11	320	400	63	2	396	324	25	19	820	4 250	18	300	900	2.5	385	335	2
320TMP12	320	440	95	3	435	325	38	28.5	1 420	6 550	44.5	220	670	3.9	418	340	2.5
340TMP12	340	460	96	3	455	345	38	29	1 450	6 800	47.4	220	650	4.2	438	360	2.5
360TMP12	360	500	110	4	495	365	45	32.5	1 870	8 600	68.1	190	570	6.7	475	383	3
380TMP12	380	520	112	4	515	385	45	33.5	1 920	8 950	82.1	180	550	7.2	495	403	3
400TMP12	400	540	112	4	535	405	45	33.5	1 960	9 350	78.0	—	540	7.9	515	423	3
420TMP11	420	500	65	2	495	424	25	20	940	5 450	24.6	—	770	4.2	485	434	2
500TMP11	500	600	80	2.1	595	505	32	24	1 420	8 300	46.5	—	620	9.6	582	516	2

6. Thrust Bearings

Bore Diameter **560-2 530**mm

Cylindrical Roller Thrust Bearings for Vertical Lathe Table

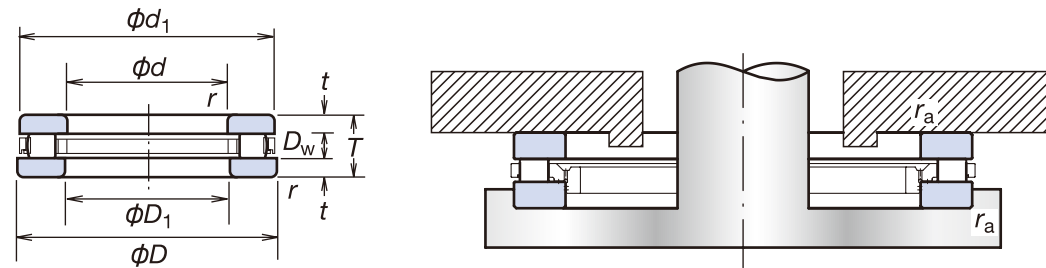

Designation	Boundary Dimensions (mm)				Reference Dimensions (mm)				Basic Load Ratings (kN)		Mass (kg) (approx.)	Minimum Load Factor (°) M (x10 ⁻⁶)	Limiting Speeds (min ⁻¹) Oil	Abutment and Fillet Dimensions (°) (mm) r _a (max.)
	d	D	T	r (min.)	d ₁	D ₁	D _w	t	C _a (Dynamic)	C _{0a} (Static)				
560TMP7001	560	700	95	4	700	560	35	30	1 690	10 200	95.5	14.6	510	3
610TMP7102A	610	710	65	4	710	610	25	20	1 080	7 300	46.5	7.5	630	3
860TMP1001	860	1 000	96	4	1 000	860	35	30.5	2 130	15 500	145	34	410	3
1240TMP1301A2	1 240	1 380	97	4	1 380	1 240	35	31	2 480	21 000	204	62	330	3
1400TMP1501B	1 400	1 520	90	3	1 520	1 400	30	30	2 120	19 800	187	55	330	2.5
1690TMP1801D	1 690	1 800	105	3	1 800	1 690	35	35	2 990	29 300	239	120	270	2.5
1930TMP2101A	1 930	2 100	105	4	2 100	1 930	35	35	2 700	27 500	434	135	240	3
2270TMP2401	2 270	2 400	120	4	2 400	2 270	40	40	4 100	44 000	448	271	200	3
2530TMP2701	2 530	2 750	150	4	2 750	2 530	50	50	5 750	60 500	1 012	512	150	3

(°) For more information on minimum load factors, please refer to page 215.

(°) Since the cages protrude from the ring faces of thrust cylindrical roller bearings, please use care when designing shafts and housings. For more details, please contact NSK.

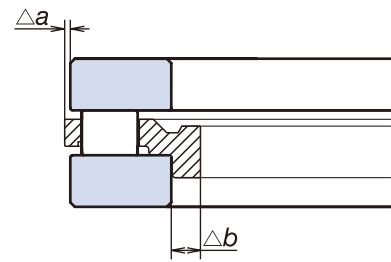

6. Thrust Bearings

High-Accuracy Low-Profile Angular Contact Ball Bearings ROBUSTSLIM



Features

A series of angular contact ball bearings that has been designed specifically for swiveling spindle heads used in machine tools, and is suitable for high-precision processing with multi-axis machines. The ROBUSTSLIM series of high-accuracy low-profile angular contact ball bearings offer high rigidity and low torque.

Low Torque Lower torque than roller bearings.

High Accuracy NRRO (Non-repeatable runout) of 0.5μm or lower was archived with BRSA130.

High Rigidity High moment stiffness on a par with crossed roller bearings.

Space-saving design Bearing width reduced by 35% or more compared to standard bearings.

Bore Diameter **130-400mm**
ROBUSTSLIM



Designation (1)	Boundary Dimensions (mm)				Basic Load Ratings (kN)		Permissible Axial Load (kN)	Contact Angle α (°)	Mass (kg/row) (reference)
	d	D	2B	r (min.)	C _a (Dynamic)	C _{oa} (Static)			
BRSA130ST21VDBCP45	130	165	22	0.6	25.4	91.0	28.5	35	0.6
BRSA170ST21VDBCP55	170	215	27	0.6	43.5	166	47.5	35	1.2
BRSA220ST21VDBCP62	220	270	31	1	57.0	243	63.5	35	2.0
BRSA340SVDBCP95	340	420	50	1.1	123	560	150.9	35	8.2
BRSA400SVDBCP100	400	500	62	1.1	176	830	221.6	35	15.4

Note: The values given in the table for preload, limiting speeds, axial rigidity, radial rigidity and moment rigidity are reference values based on the axial clearance specified in the "Designation" column.

Numbering System of High-Accuracy Low-Profile Angular Contact Ball Bearings ROBUSTSLIM

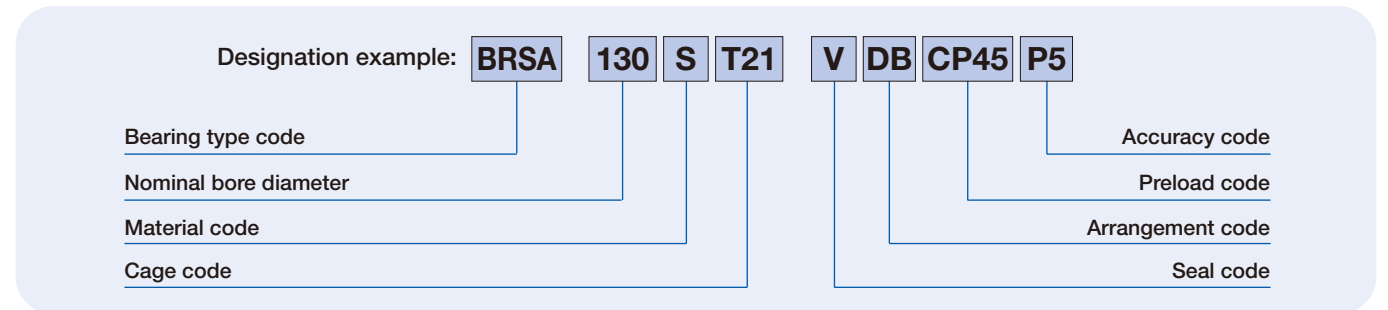

Code	Category	Description	Reference pages
BRSA	Bearing type	BRSA: contact angle 35°	44-45
130	Nominal bore diameter	Bore dimensions (mm): 130, 170, 220, 340,400	174-175
S	Material	S: Inner/outer ring SUJ2 or SUJ3, balls SUJ2	14-15
T21	Cage	T21: Ring guided resin cage No code: Ring guided machined brass cage	—
V	Seal	V: Non-contact rubber seal on one side	—
DB	Arrangement	DB: Back-to-back arrangement	200-201
CP45	Preload	CP: Special preload gap	210
P5	Accuracy	P5: Class 5	222-225

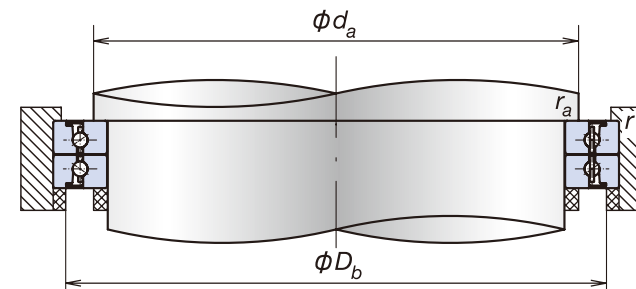

Abutment and Fillet Dimensions (mm)				Preload (kN)	Limiting Speeds (min ⁻¹) Grease	Axial rigidity (kN/μm)	Radial rigidity (kN/μm)	Moment Rigidity (kN·m/mrad)
d _a (min.)	D _b (max.)	r _a (max.)	r _b (max.)					
135	160	0.6	0.6	18	260	2.6	1.8	7.9
175	210	0.6	0.6	29	200	3.4	2.4	17.9
226	264	1	1	43	150	4.4	3.1	37.3
347	413	1	1	95	100	6.5	4.7	134
407	493	1	1	111	80	7.2	5.4	210

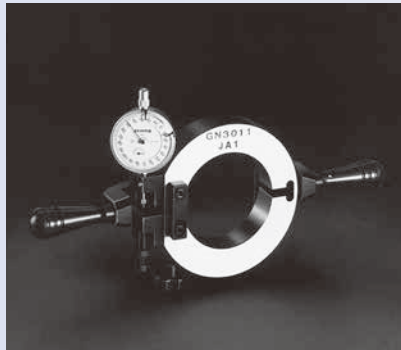

Peripheral Equipment

- Gauges178-181
 - GR Gauges
 - Features
 - Numbering System
 - GN Gauges
 - Features
 - Numbering System
- NSK Induction Bearing Heaters182-183
- Grease Replenishing System FINE-LUB II184-185
- High Speed Built-In Motor Spindle186-187

Ring Gauges GR Series

Housing bore diameter precision measuring gauges

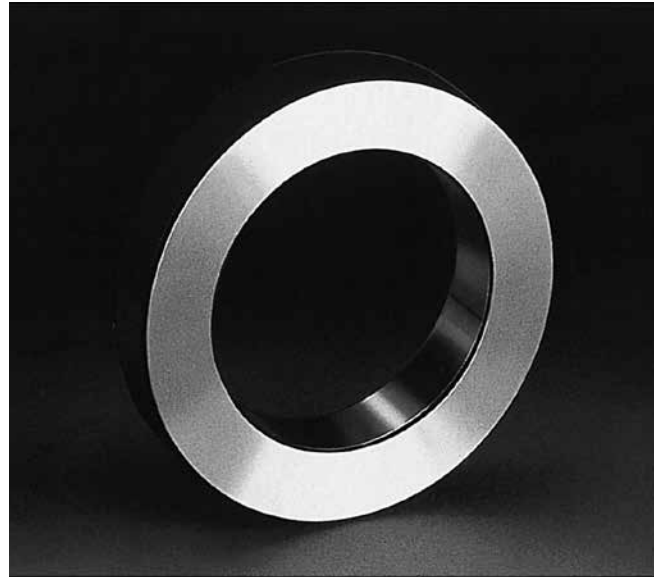

To obtain satisfactory performance of precision rolling bearings for machine tool spindles, it is important to have an accurate fit with the shaft and housing.

To achieve an accurate fit, it is necessary to measure the shaft outside diameter and housing bore exactly.

NSK Ring Gauges GR series are master gauges for measuring the bore diameters of housings within an accuracy of 0.001 mm.

Features

- Ring design enables reliable cylinder gauge settings.
- Ring thickness prevents any deformation caused by measuring pressure.
- Heat treatment during manufacturing of the ring negates any effects of aging on ring dimensions.
- Exact gauging is possible due to precisely measured dimensions that are marked on the gauges in 0.001 mm units in both the X and Y directions.

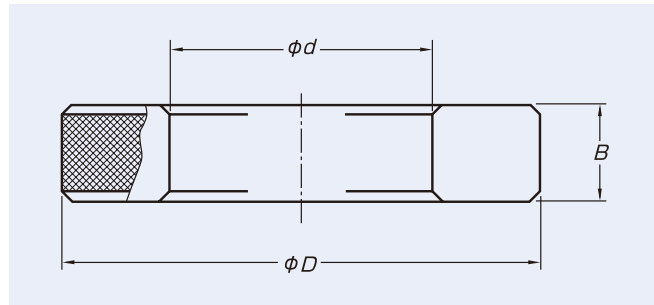

Applicable Bearings					Gauge Numbers	Boundary Dimensions (mm)			Mass (kg) (approx.)
79 69 NN39 NN49	BNR19 BER19	70 60 N10 NN30	BNR10 BER10	72 62 N2		<i>d</i>	<i>D</i>	<i>B</i>	
—	—	00	—	—	GR 26	26	75	20	0.6
02	—	01	—	—	GR 28	28	75	20	0.6
03	—	—	—	00	GR 30	30	80	20	0.7
—	—	02	—	01	GR 32	32	80	20	0.7
—	—	03	—	02	GR 35	35	85	20	0.7
04	—	—	—	—	GR 37	37	85	20	0.7
—	—	—	—	03	GR 40	40	90	20	0.8
05	—	04	—	—	GR 42	42	95	20	0.9
06	—	05	—	04	GR 47	47	95	20	0.8
07	—	—	—	05	GR 52	52	100	20	0.9
—	—	06	30	—	GR 55	55	100	20	0.9
08	—	07	35	06	GR 62	62	100	20	0.8
09	—	08	40	—	GR 68	68	110	20	0.9
10	50	—	—	07	GR 72	72	115	20	1.0
—	—	09	45	—	GR 75	75	115	20	0.9
11	55	10	50	08	GR 80	80	120	25	1.2
12	60	—	—	09	GR 85	85	130	25	1.5
13	65	11	55	10	GR 90	90	135	25	1.5
—	—	12	60	—	GR 95	95	140	25	1.6
14	70	13	65	11	GR 100	100	145	25	1.7
15	75	—	—	—	GR 105	105	150	25	1.8
16	80	14	70	12	GR 110	110	160	25	2.1
—	—	15	75	—	GR 115	115	165	25	2.1
17	85	—	—	13	GR 120	120	170	25	2.2
18	90	16	80	14	GR 125	125	175	25	2.3
19	95	17	85	15	GR 130	130	180	25	2.4
20	100	18	90	16	GR 140	140	190	25	2.5
21	105	19	95	—	GR 145	145	200	30	3.5
22	110	20	100	17	GR 150	150	205	30	3.6
—	—	21	105	18	GR 160	160	215	30	3.8
24	120	—	—	—	GR 165	165	220	30	3.9
—	—	22	110	19	GR 170	170	225	30	4.0
26	130	24	120	20	GR 180	180	230	30	3.8
28	140	—	—	21	GR 190	190	240	30	4.0
—	—	26	130	22	GR 200	200	250	30	4.1

GN Gauges GN30 Series

Precision measuring gauges for residual radial clearance of double-row cylindrical roller bearings (NN30XX)

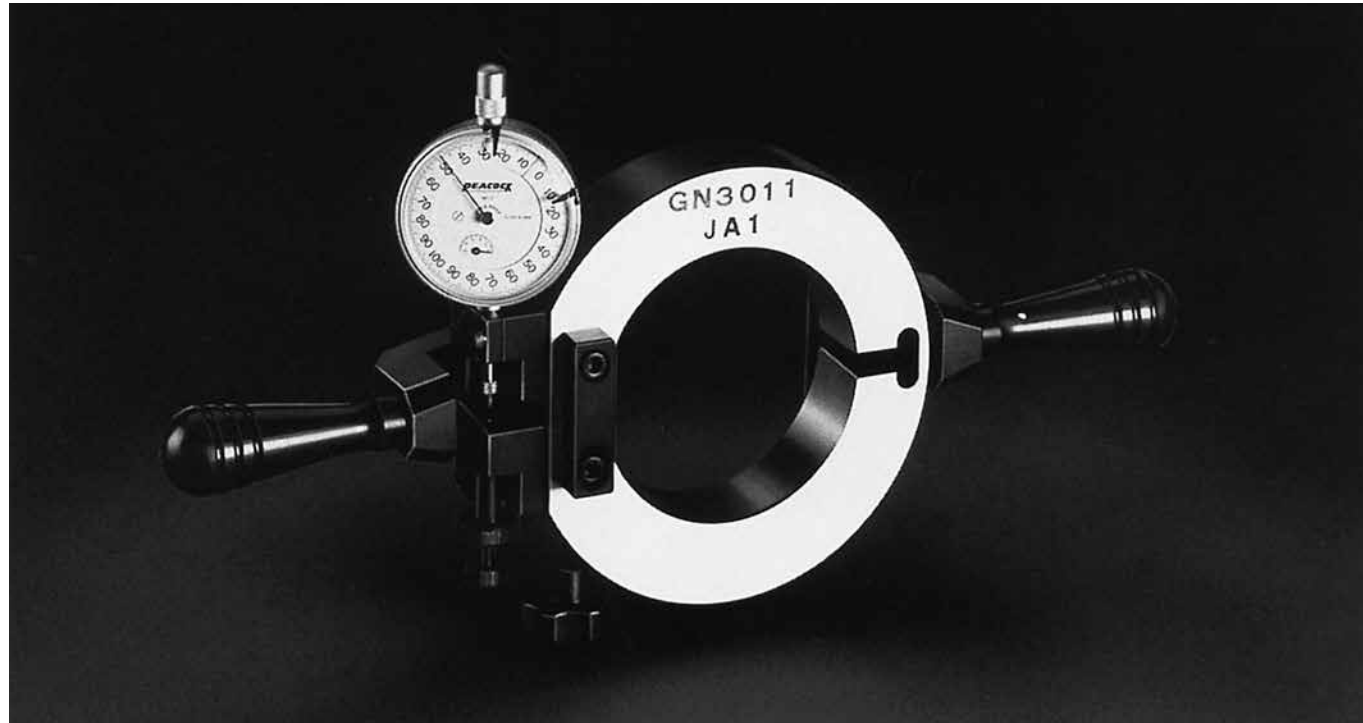

When mounting a double-row cylindrical roller bearing with a tapered bore onto a shaft, it is important to accurately match the shaft taper with that of the bearing, and to ensure that the desired radial internal clearance is attained after mounting.

If there is excessive residual radial internal clearance, the spindle will have some play and machining accuracy will be adversely affected. If preload is too large, despite little or no change in rigidity, heat generation will become excessive and rolling fatigue life will be extremely shortened (See page 215).

With the recent trends toward higher speed and higher precision, it is necessary to control residual radial internal clearance more carefully. In the past, radial clearance measuring methods were very difficult and required much skill. GN gauges developed by NSK for residual radial internal clearance measurements of double-row cylindrical roller bearings simplify bearing mounting and improve mounting accuracy. (Use of GN gauges also requires a bore measuring cylinder gauge.)

For details on how to use GN gauges, please refer to page 250.

Features

- Reliable and accurate measurements made simple.
- No more complicated calculations for corrections based on interference of outer ring with housing.
- Both positive and negative clearance (preload) can be measured.
- Accurate measurements are obtained since all GN gauges are calibrated for measuring pressure.

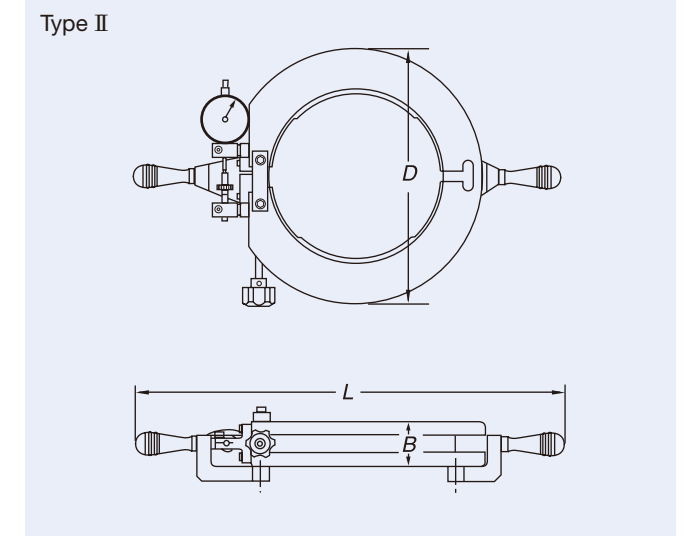
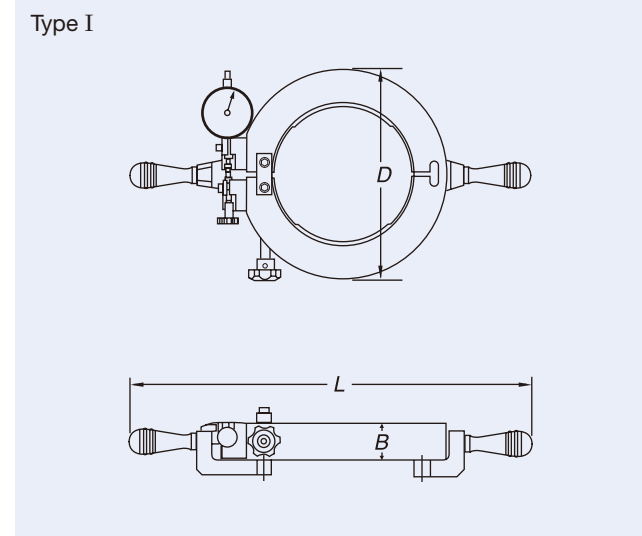

Applicable Bearings	Gauge Numbers	Types	Boundary dimensions (mm)			Mass (kg) (approx.)
			D	B	L	
NN3007	GN3007	I	102	23	292	1.3
NN3008	GN3008	I	108	23	297	1.4
NN3009	GN3009	I	115	23	305	1.5
NN3010	GN3010	I	120	23	310	1.6
NN3011	GN3011	I	131	26	324	2.1
NN3012	GN3012	I	138	26	329	2.2
NN3013	GN3013	I	145	26	335	2.4
NN3014	GN3014	I	156	30	347	3.0
NN3015	GN3015	I	162	30	353	3.1
NN3016	GN3016	I	175	33	374	4.2
NN3017	GN3017	I	185	33	381	4.3
NN3018	GN3018	I	195	35	393	5.2
NN3019	GN3019	I	204	35	399	5.6
NN3020	GN3020	I	210	35	411	6.1
NN3021	GN3021	I	224	39	419	7.1
NN3022	GN3022	I	233	44	433	8.5
NN3024	GN3024	II	254	44	470	7.5
NN3026	GN3026	II	280	50	492	9.5
NN3028	GN3028	II	289	50	500	9.5
NN3030	GN3030	II	314	54	520	12
NN3032	GN3032	II	329	54	540	13

High-Speed Built-in Motor Spindle Series

Three technologies supporting NSK high-speed spindles

NSK's leading technologies in bearings, lubrication and design are combined in these high performance built-in motor spindles for machining centers. Their heavy cutting capability, ultra low noise and low environmental impacts far exceed those of conventional high-speed spindles.



Bearing Technology

Incorporates the NSKROBUST Series, proven bearings for machine tools. Ceramic balls are used for higher speed, high rigidity, and high reliability.

Cool running

Optimization of internal design realizes cool running.

Improved anti-seizure property

Improved heat robustness to handle changes in ambient temperatures.

Ceramic ball

Adopts a high-precision ceramic ball for the rolling element to provide high speed, high precision, and high rigidity.



Lubrication Technology

Supports 10 000 hours of maintenance-free performance with grease replenishing lubrication. NSK's new proprietary, environmentally friendly lubrication method automatically delivers a small quantity of grease into the bearing interior at intermittent intervals.

Improved grease life

Continuous fresh supply of lubricant to components improves grease life.

Ultra low noise

Eliminates grating wind noise caused by oil-air lubrication.

Reduced energy consumption

With air consumption lowered by at least 70%, as little as 50 NL/min of air is required.

Environmentally sound

No oil is consumed, and therefore no oil particles are released into the air.



Design Technology

Adopts a built-in motor structure optimized to limit vibration. A direct-drive system with no gears or couplings produces low vibration.

Low vibration

Provides improved quality in cut surface and extends tool life.

Compact

The spindle incorporates motor between bearings at front and rear and is therefore lighter and more compact than direct-coupled units.

Simplified assembly

Incorporating spindle shaft and motor into single unit eliminates need for centering and aligning spindle shaft and motor.

Easier maintenance

Unique cartridge structure allows components to be quickly replaced.

NSK Built-In Motor Spindles

POWER	Top Class Rigidity 12,000 min⁻¹ High-Rigidity / High-Power Type Lubrication Grease replenishing system Brg. Bore $\phi 80\text{mm}$ ($d_{in} 123 \times 10^3$) Preload Position preload Ideal for machining automotive parts	World's Top Speed 25,000 min⁻¹ High-Speed / High-Power Type Lubrication Grease replenishing system Brg. Bore $\phi 70\text{mm}$ ($d_{in} 225 \times 10^3$) Preload Constant pressure preload Ideal for machining aluminum and metal molds
	High-performance spindles that deliver unmatched capabilities in high-speed Class #40 machining centers. Our elite lineup offers heavy cutting power, extremely quiet operation, and low environmental impacts.	15,000/20,000 min⁻¹ Standard / High-Speed Type Lubrication Packed grease / Grease replenishing system Brg. Bore $\phi 70\text{mm}$ ($d_{in} 128 \times 10^3 / d_{in} 170 \times 10^3$) Preload Position preload Suits a wide range of applications
	SPEED	

Features

Low noise and vibration

NSK's grease replenishing system eliminates the wind noise associated with oil-air lubrication. A direct drive without gears or couplings employs balance correction technologies that result in low noise and low vibration.

Low environmental load

The spindles of this series operate in a clean and energy-efficient way. Air and oil consumption for bearing lubrication are brought to zero, no oil particles are released into the atmosphere and there are no large quantities of oil dripping onto the work piece.

All-in-one concept with high variability

- Our grease replenishing system FINE-LUB II enabled us to develop this series of grease-lubricated high-speed spindles.
- Components such as bearings, motor, tool clamping parts etc. have been integrated in to a single unit. This reduces production lead time and cuts maintenance costs.
- Standard spindles in the series offer BT40 or HSK A63 options, S and L type configurations, and grease replenishing or packed grease specifications. In addition, various options such as through-spindle coolant or flood coolant specifications are available.

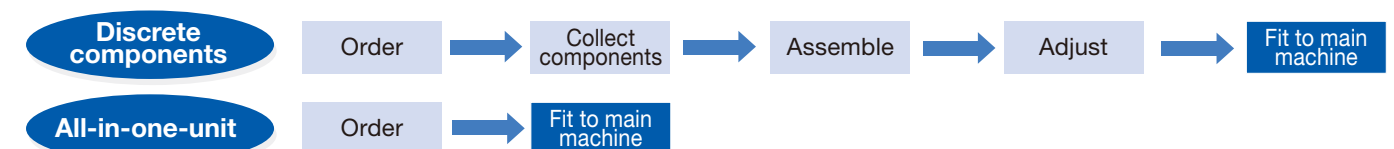
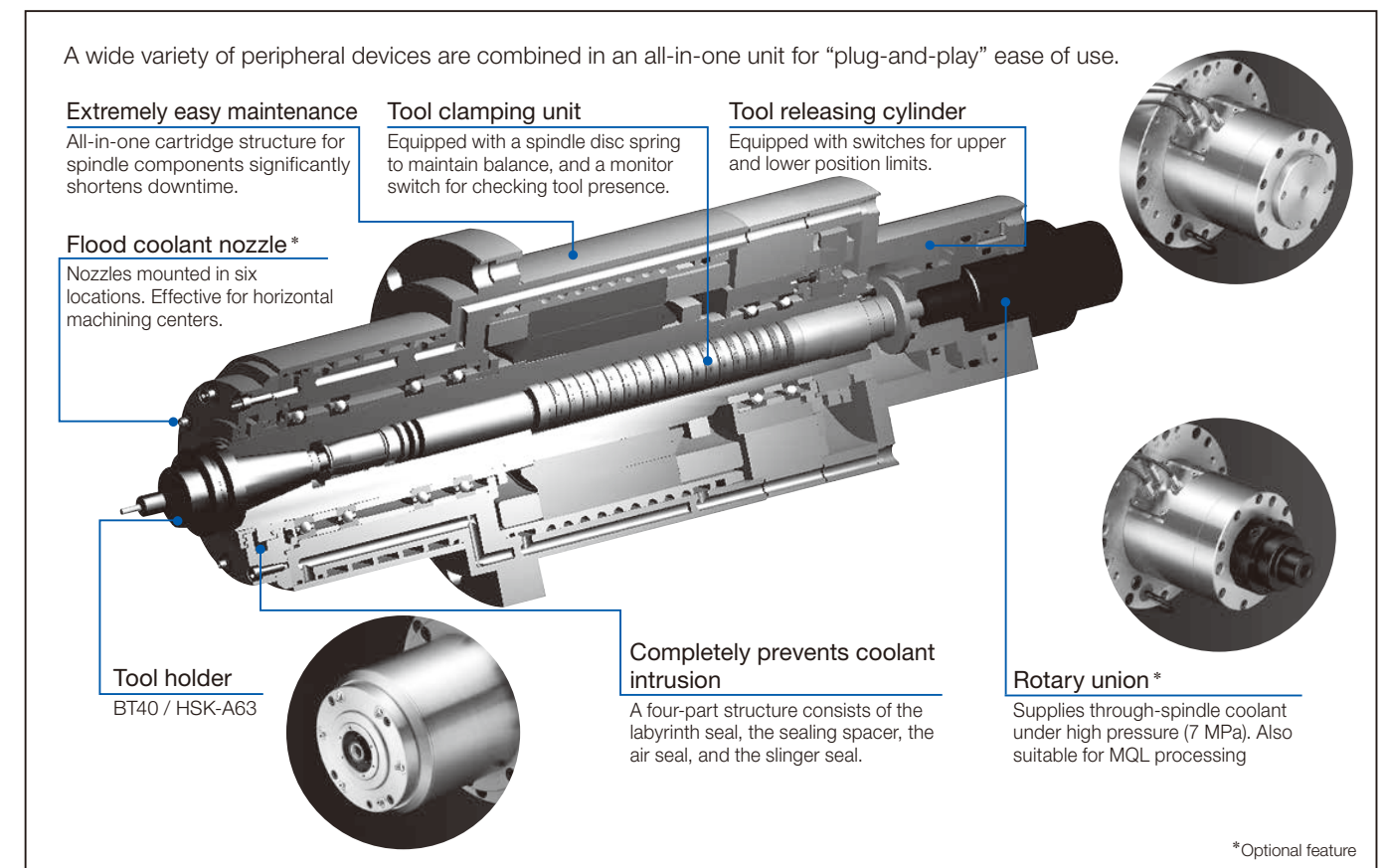

Reduced production lead time

- Significantly reduces time from order to completion of spindle adjustment.
- Reduces running stock.

Cut maintenance costs

- Spindles can be used for different machines in the factory.
- Reduces spare unit inventory.

7. Peripheral Equipment

Specifications of Built-in Motor Spindle

Designation will be included in the specification drawings of supplied products. When ordering, please provide the designation for the product you would like to purchase.

Designation example: W-B 11 00-0 4 1 3 3 0

Spindle type	B: Standard / High-Speed Type S: High-Rigidity / High-Power Type F: High-Speed / High-Power Type	Seal	0: Standard seal
Mounting dimensions	11: S-type 12: L-type, High-Rigidity / High-Power, High-Speed / High-Power Types	Monitor switch	3: Tool presence checker and release cylinder with upper and lower limits
Flange	0: Standard position	Coolant (Option)	0: None 1: Through-spindle coolant 2: Flood coolant 3: Combined through-spindle / flood coolant
Main Shaft Taper/ Rotational Speed	0: BT40/15 000/12 000 1: BT40/20 000 2: HSK-A63/15 000/12 000 4: HSK-A63/20 000/25000	Note: The High-Speed / High-Power Type (W-F1200) is not compatible with flood coolant specifications, and therefore requires a code of 0 or 1.	
Lubrication	0: Packed grease 1: Grease replenishing system Packed grease (0) can only be used in following configurations: W-B1100-00**** W-B1100-03**** W-B1200-00**** W-B1200-03****		

Dimensions

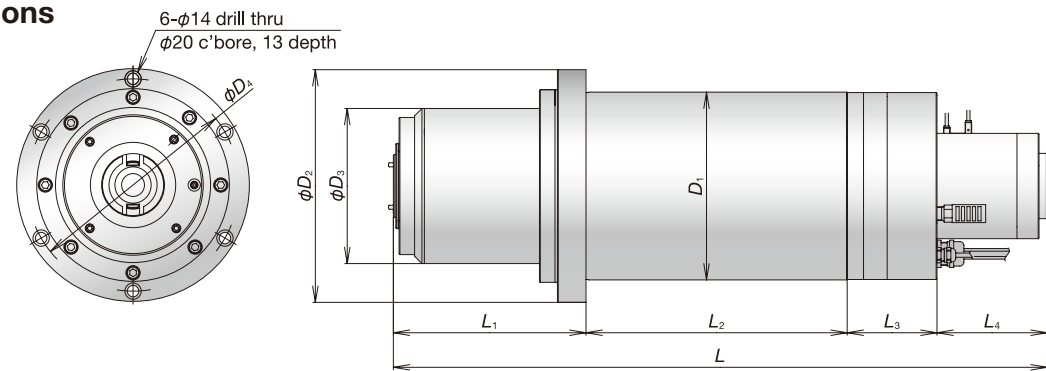

Item	Unit	S-type		L-type		High-Rigidity / High-Power Type	High-Speed / High-Power Type
		Standard	High-Speed	Standard	High-Speed		
Bearing bore	(mm)	ø70	ø70	ø70	ø70	ø80	ø70
Speed	(min ⁻¹)	15 000	20 000	15 000	20 000	12 000	25 000
Tool shank	-	BT40	←	BT40	←	BT40	HSK-A63
Bearing lubrication	-	HSK-A63	←	HSK-A63	←	HSK-A63	HSK-A63
Output (short-time/continuous)	(kW)	Packed grease	Grease replenishing	Packed grease	Grease replenishing	Grease replenishing	Grease replenishing
Torque	(N)	18.5 (10min) / 11	←	22 (15min) / 18.5	←	25 (15min) / 22	30 (25%ED) / 22
D1	(mm)	210	←	230	←	230	230
D2	(mm)	265	←	285	←	285	285
D3	(mm)	170	←	170	←	190	180
D4	(mm)	240	←	260	←	260	260
L	(mm)	670	←	800	←	801	670
L1	(mm)	235	←	235	←	236	140
L2	(mm)	190	←	320	←	320	270
L3	(mm)	110	←	110	←	110	125
L4	(mm)	135	←	135	←	135	135

Specifications of Built-in Motor

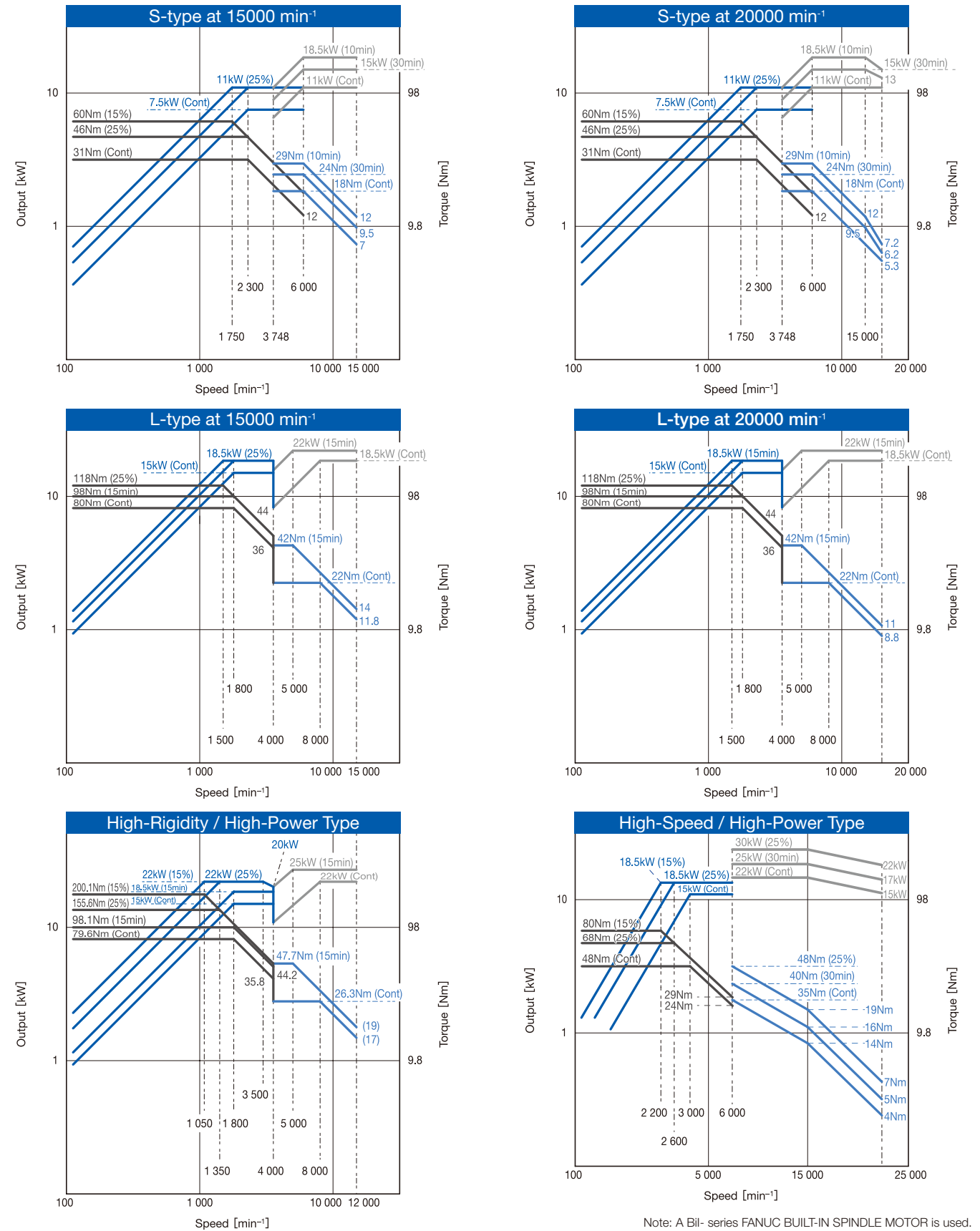

Note: A Bil-series FANUC BUILT-IN SPINDLE MOTOR is used. Please prepare an amplifier, NC, etc. as necessary.

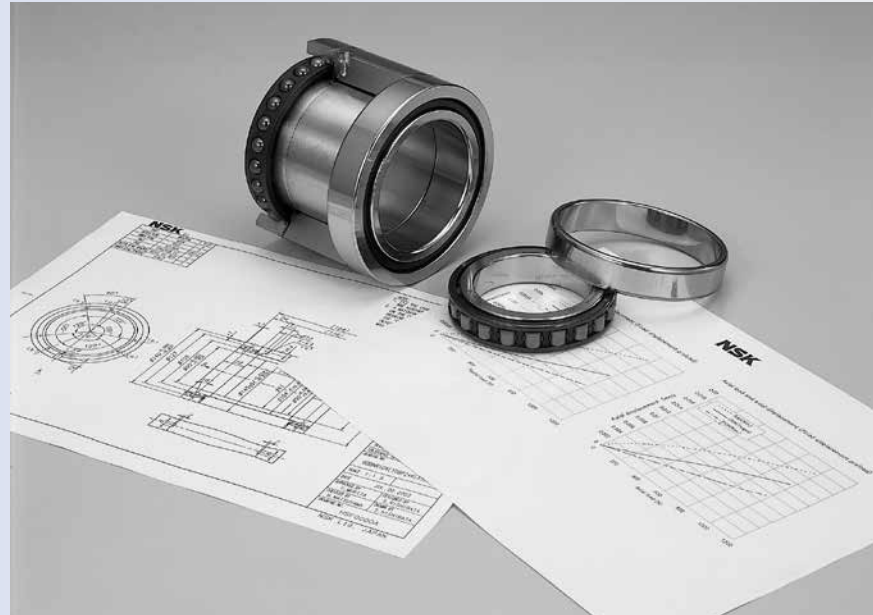

Technical Guide

- 1. Life190-197
 - Rolling Fatigue Life and Basic Dynamic Load Rating
 - New Life Theory
 - Features of Micro-UT™
- 2. Static Load Ratings and Static Equivalent Loads ...198-199
- 3. Angular Contact Ball Bearing Combinations200-205
 - Features of Each Combination
 - Universal Arrangement
- 4. Preload and Rigidity206-215
 - Types of Preload and Rigidity
- 5. Limiting Speeds216-217
- 6. Lubrication218-221
- 7. Bearing Tolerances222-231
 - Tolerances for Radial Bearings
 - Tolerances for Tapered Bores
 - Tolerances for Thrust Ball Bearings
- 8. Designing of Shafts and Housings232-236
 - Fitting of Shafts and Housings
 - Shaft and Housing Tolerances
 - Chamfer Dimensions
- 9. Spacers.....237-241
 - Spacer Dimensions
 - Position of Spray Nozzle

Life

Static Load Ratings and Static Equivalent Loads

Angular Contact Ball Bearing Combinations

Preload and Rigidity

Limiting Speeds

Lubrication

Bearing Tolerances

Design of Shafts and Housings

Spacers

Rolling Fatigue Life and Basic Dynamic Load Rating

Bearing Life

The functions required of rolling bearings vary according to the bearing application, and these functions must be performed for a prolonged period. Even if bearings are properly mounted and correctly operated, they will eventually fail to perform satisfactorily due to an increase in noise and vibration, loss of running accuracy, deterioration of grease, or fatigue flaking of the rolling surfaces. In the broad sense of the term, bearing life refers to the period during which bearings continue to operate and satisfy their required functions. Depending on the cause of bearing failure, this bearing life may be defined as:

- noise life
- grease life
- rolling fatigue life

Besides natural deterioration, bearings may fail due to:

- heat seizure
- fracture or cracks
- wear
- rings becoming scored
- damaged seals

If the bearing fails for such reasons, this should not be interpreted as normal bearing life because these failures often occur as a result of selecting the wrong bearings, improper design or manufacture of the bearing surroundings, incorrect mounting, or insufficient maintenance.

Rolling Fatigue Life and Basic Rating Life

When rolling bearings are operated under load, the raceways of their inner and outer rings and rolling elements are subjected to repeated cyclic stress. The rolling contact surfaces of the raceways and rolling elements experience metal fatigue, and scaly particles may separate from the bearing material in a phenomenon called “flaking”. Rolling fatigue life is represented by the total number of revolutions at which the bearing surface will start flaking due to stress. Rolling fatigue life is often also called “bearing life” when the term is used in a more narrow sense.

Even for seemingly identical bearings of the same type, size, and material that receive the same heat treatment and other processing, the rolling fatigue life varies greatly, even under identical operating conditions. This is because the flaking of materials due to fatigue is subject to many other variables. Consequently, the concept of “basic rating life”, in which rolling fatigue life is treated as a statistical phenomenon, is used in preference to actual rolling fatigue life.

Suppose a number of bearings of the same type are operated individually under the same conditions. After a certain period, 10% of them will fail as a result of flaking caused by rolling fatigue. The total number of revolutions at this point is defined as the basic rating life. If the speed is constant, the basic rating life is often expressed by the total number of operating hours completed when 10% of the bearings become inoperable due to flaking.

In determining bearing life, basic rating life is often the only factor considered. However, other factors must also be taken into account. For example, it is possible to approximate the grease life of bearings prelubricated with grease. Since noise life and abrasion life are determined according to individual standards for different applications, specific values for noise or abrasion life have to be determined empirically.

Basic Dynamic Load Rating

The basic dynamic load rating applies to bearings with stationary outer rings and rotating inner rings. It is defined as the constant load that the bearing can endure for a rating life of one million revolutions (10^6 rev). For radial bearings, the basic dynamic load is given as a central radial load in a constant direction and magnitude, while the basic dynamic load rating of thrust bearings is given as an axial load of constant magnitude in the same direction as the central axis. The basic dynamic load ratings are listed in the bearing tables under C_r for radial bearings and C_a for thrust bearings.

The basic dynamic load rating of multi-row bearing arrangements can be calculated using the following formula:

$$\text{for ball bearings: } C_j = j^{0.7} \times C_1$$

$$\text{for roller bearings: } C_j = j^{7/9} \times C_1$$

where j : Number of rows ($j \geq 2$)

C_1 : Basic dynamic load rating for single-row bearings

C_j : Basic dynamic load rating for multi-row bearings (where j is the number of rows)

Special care must be taken when calculating the basic dynamic load rating C_a for thrust bearings, as j refers to the number of rows sustaining axial load only. For example, only two rows sustain the axial load in a four-row DBB arrangement; thus $j = 2$.

Steel ball bearings are specified by ISO 281 and hybrid bearings (ceramic ball bearings) by ISO 20056-1.

Basic Rating Life

The following relationships exist between basic dynamic load rating, dynamic equivalent load, and basic rating life:

$$\begin{aligned} \text{for ball bearings: } L_{10} &= \left(\frac{C}{P}\right)^3 (10^6 \text{ rev}) \\ L_{10} &= \frac{10^6}{60n} \left(\frac{C}{P}\right)^3 \quad (\text{h}) \end{aligned}$$

$$\begin{aligned} \text{for roller bearings: } L_{10} &= \left(\frac{C}{P}\right)^{10/3} (10^6 \text{ rev}) \\ L_{10} &= \frac{10^6}{60n} \left(\frac{C}{P}\right)^{10/3} \quad (\text{h}) \end{aligned}$$

P : Dynamic equivalent load (N)
 C : Basic dynamic load rating (N)
 n : Rotational speed (min^{-1})

For bearings that run at a constant speed, it is convenient to express the fatigue life in terms of hours.

Dynamic Equivalent Load

In some cases, the loads applied on bearings are purely radial or axial loads; however, in most cases, the loads are a combination of both. In addition, such loads usually fluctuate in both magnitude and direction.

In such cases, the loads actually applied to bearings cannot be used for bearing life calculations; therefore, a hypothetical load should be estimated that has a constant magnitude, passes through the center of the bearing, and achieves the same bearing life as the bearing would attain under actual conditions of load and rotation. Such a hypothetical load is called the dynamic equivalent load.

Assuming the equivalent radial load as P_r , the radial load as F_r , the axial load as F_a , and the contact angle as α , the relationship between the equivalent radial load and bearing load can be approximated as follows:

$$P_r = XF_r + YF_a$$

where: X : Radial load factor } see Table 1.1
 Y : Axial load factor }

The axial load factor varies depending on the contact angle. For roller bearings, the contact angle remains the same regardless of the magnitude of the axial load. In the case of single-row deep groove ball bearings and angular contact ball bearings, the contact angle increases when the axial load is increased. Such change in the contact angle can be expressed by the ratio of the basic static load rating C_0 and the axial load F_a . Table 1.1 shows the axial load factor at the contact angle corresponding to this ratio. Regarding angular contact ball bearings, if the contact angle is 25° , 30° , or 40° , the effect of contact angle change on the load factor may be ignored under normal operating conditions.

For thrust bearings with contact angles of $\alpha \neq 90^\circ$ that

receive both radial and axial loads simultaneously, the equivalent axial load P_a becomes as follows:

$$P_a = XF_r + YF_a$$

Relationship between Bearing Life and Contact Angle

When a load is applied to an angular contact ball bearing, the amount of stress at the contact point changes as a result of the varying load conditions of the balls, inner ring, and outer ring relative to the contact angle of the bearing.

Figure 1.1 illustrates loads acting on two rolling elements at a 30° contact angle and a 15° contact angle.

The relationship between an axial load applied to the bearing and the resulting load acting on the rolling element can be formulated as:

Load on rolling element = $F_a / (\text{number of balls} \times \sin \alpha)$.
 Therefore, the larger the contact angle, the smaller the load acting on the rolling element. The load at the contact point and its consequential deformation are reduced, thus resulting in longer life.

When a radial load is applied, the smaller the contact angle, the smaller the load acting on the rolling element. This results in reduced load at the contact point.

For these reasons, bearing life varies according to the contact angle under the same load conditions.

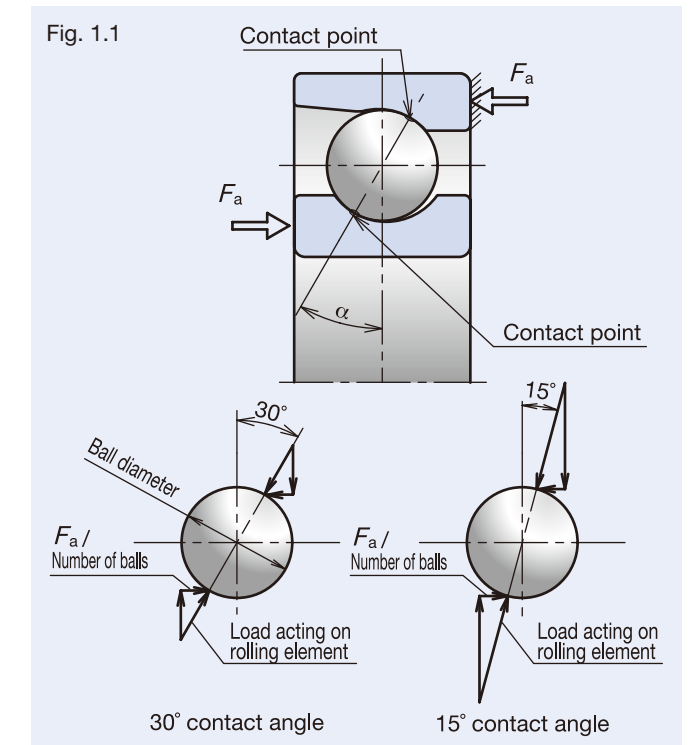

Table 1.1 Value of Factors X and Y for Calculation of Equivalent Load $P = XF_r + YF_a$

Bearing type	$\frac{if_0 F_a}{C_{or}}$	e	Single row (i=1)				DB (i=2)							
			DT (i=1)		DTD (i=1)		DTT (i=1)		DF (i=2)		DBB (i=2)		DFF (i=2)	
			$F_a/F_r \leq e$		$F_a/F_r > e$		$F_a/F_r \leq e$		$F_a/F_r > e$		$F_a/F_r \leq e$		$F_a/F_r > e$	
			X	Y	X	Y	X	Y	X	Y	X	Y		
Angular contact ball bearings (C=C _r)	15°	0.178	0.38				1.47		1.65		2.39			
		0.357	0.40				1.40		1.57		2.28			
		0.714	0.43				1.30		1.46		2.11			
		1.07	0.46	1	0	0.44	1.23	1	1.38	0.72	2.00			
		1.43	0.47				1.19		1.34		1.93			
		2.14	0.50				1.12		1.26		1.82			
		3.57	0.55				1.02		1.14		1.66			
		5.35	0.56				1.00		1.12		1.63			
	18°	0.181	0.44				1.30		1.42		2.11			
		0.363	0.46				1.25		1.37		2.03			
		0.726	0.48				1.18		1.30		1.92			
		1.09	0.50	1	0	0.43	1.14	1	1.25	0.70	1.85			
1.45		0.52				1.10		1.21		1.79				
2.18		0.54				1.05		1.15		1.70				
3.63	0.57				1.00		1.10		1.63					
25°	—	0.68	1	0	0.41	0.87	1	0.92	0.67	1.41				
30°	—	0.80	1	0	0.39	0.76	1	0.78	0.63	1.24				
40°	—	1.14	1	0	0.35	0.57	1	0.55	0.57	0.93				
Angular contact thrust ball bearings (C=C _a)	30°	—	0.72	—	—	0.48	1	0.74	0.55	0.48	1			
	40°	—	1.05	—	—	0.60	1	1.01	0.64	0.60	1			
	55°	—	1.79	—	—	0.81	1	1.60	0.60	0.81	1			
	60°	—	2.17	—	—	0.92	1	1.90	0.56	0.92	1			
Tapered roller bearings (°)	—	1.5tan α	1	0	0.4	0.4cot α	1	0.45cot α	0.67	0.67cot α				

Bearing type	e	DBBD				DFFD				
		Axial load supported by 3 rows				Axial load supported by 2 rows				
		$F_a/F_r \leq e$		$F_a/F_r > e$		$F_a/F_r \leq e$		$F_a/F_r > e$		
		X	Y	X	Y	X	Y	X	Y	
Angular contact thrust ball bearings (C=C _a)	30°	0.72	0.84	0.64	0.48	1	0.63	0.64	0.48	1
	40°	1.05	1.15	0.60	0.60	1	0.87	0.60	0.60	1
	55°	1.79	1.82	0.56	0.81	1	1.37	0.56	0.81	1
	60°	2.17	2.15	0.55	0.92	1	1.62	0.55	0.92	1

DBD										DBT													
DFD										DFT													
Axial load supported by 2 rows					Axial load supported by 1 row					Axial load supported by 3 rows					Axial load supported by 1 row								
i	$F_a/F_r \leq e$		$F_a/F_r > e$		i	$F_a/F_r \leq e$		$F_a/F_r > e$		i	$F_a/F_r \leq e$		$F_a/F_r > e$		i	$F_a/F_r \leq e$		$F_a/F_r > e$					
	X	Y	X	Y		X	Y	X	Y		X	Y	X	Y		X	Y						
3/2	1	0.87			1.97	3	1	3.07			3.19	4	1	0.59			1.81	4	1	4.35			3.90
		0.83			1.86			2.91			3.02			0.56			1.71			4.12			3.70
		0.77			1.73			2.71			2.82			0.52			1.60			3.84			3.45
		0.73		0.59	1.65			2.58		0.95	2.68			0.50		0.54	1.52			3.65		1.17	3.28
		0.70			1.58			2.48			2.57			0.48			1.46			3.51			3.15
		0.66			1.49			2.33			2.42			0.45			1.37			3.30			2.96
		0.61			1.37			2.14			2.22			0.41			1.26			3.02			2.71
		0.56			1.27			1.98			2.06			0.40			1.22			2.94			2.64
3/2	1	0.75			1.72	3	1	2.63			2.80	4	1	0.51			1.57	4	1	3.73			3.38
		0.72			1.66			2.53			2.69			0.49			1.51			3.59			3.26
		0.68		0.57	1.57			2.40		0.93	2.55			0.46		0.53	1.43			3.41		1.15	3.09
		0.65			1.51			2.31			2.45			0.45			1.38			3.28			2.97
		0.63			1.46			2.24			2.38			0.43			1.34			3.18			2.88
		0.60			1.39			2.12			2.26			0.41			1.27			3.02			2.74
		0.56			1.29			1.97			2.10			0.40			1.22			2.91			2.64
		—	1	0.48	0.54			1.16	—	1	1.71			0.89	1.88	—	1			0.33	0.50	1.08	—
—	1	0.41	0.52	1.01	—	1	1.45	0.84	1.64	—	1	0.28	0.48	0.93	—	1	2.05	1.03	2.01				
—	1	0.29	0.46	0.76	—	1	1.02	0.76	1.23	—	1	0.20	0.42	0.71	—	1	1.46	0.92	1.54				
—	0.91	0.41	0.48	1	—	0.56	0.89	0.48	1	—	0.98	0.30	0.48	1	—	0.46	1.04	0.48	1				
—	1.24	0.39	0.60	1	—	0.76	0.84	0.60	1	—	1.35	0.29	0.60	1	—	0.62	0.98	0.60	1				
—	1.95	0.36	0.81	1	—	1.20	0.78	0.81	1	—	2.12	0.27	0.81	1	—	0.98	0.90	0.81	1				
—	2.32	0.35	0.92	1	—	1.43	0.76	0.92	1	—	2.52	0.26	0.92	1	—	1.17	0.88	0.92	1				

DBTD										DBTT									
DFTD										DFTT									
Axial load supported by 4 rows					Axial load supported by 1 row					Axial load supported by 5 rows					Axial load supported by 1 row				
$F_a/F_r \leq e$		$F_a/F_r > e$		$F_a/F_r \leq e$		$F_a/F_r > e$		$F_a/F_r \leq e$		$F_a/F_r > e$		$F_a/F_r \leq e$		$F_a/F_r > e$		$F_a/F_r \leq e$		$F_a/F_r > e$	
X	Y	X	Y	X	Y	X	Y	X	Y	X	Y	X	Y	X	Y	X	Y		
1.03	0.64	0.48	1	0.39	0.64	0.48	1	1.06	0.64	0.48	1	0.34	0.64	0.48	1				
1.41	0.60	0.60	1	0.53	0.60	0.60	1	1.45	0.60	0.60	1	0.47	0.60	0.60	1				
2.22	0.56	0.81	1	0.84	0.56	0.81	1	2.28	0.56	0.81	1	0.74	0.56	0.81	1				
2.63	0.55	0.92	1	1.00	0.55	0.92	1	2.71	0.55	0.92	1	0.88	0.55	0.92	1				

Note: For tapered roller bearings, please also refer to the values listed in the bearing tables on pages 160 and 161.

New Life Theory

Introduction

The conventional life calculation formula based on the theories of G. Lundberg and A. Palmgren addresses only subsurface-originated flaking. This phenomenon occurs from cracks due to dynamic shear stress immediately below the rolling surface that progressively reach the surface in the form of flaking.

In recent years, bearing technology has advanced considerably, particularly in the areas of dimensional accuracy and material cleanliness. In addition, progress has been made in bearing-related technology such as lubrication cleanliness and filtration. As a result, bearings can now have a longer rolling fatigue life in a cleaner environment than the life obtained by the traditional ISO life calculation formula.

NSK's new life calculation formula theorizes that rolling fatigue life is the sum total of the combined effects of both subsurface-originated flaking and surface-originated flaking occurring simultaneously.

Composition of NSK's New Life Calculation

Formula

(1) Subsurface-originated flaking

A precondition of subsurface-originated flaking in rolling bearings is contact of the rolling elements with the raceway surface via a sufficient oil film under clean lubrication conditions.

Fig. 1.2 plots the L_{10} life for each test condition regarding the maximum surface contact pressure (P_{max}) along the y-axis and the number of repeated stress cycles applied along the x-axis. In the figure, line L_{10} theoretical is obtained using the conventional life calculation formula. As maximum surface contact pressure decreases, the line representing actual life separates from the conventional line and moves towards longer life. This separation suggests the presence of a fatigue load limit P_u below which no rolling fatigue occurs. The following equation introduces a fatigue limit for subsurface-originated flaking into the Lundberg-Palmgren theory:

Fig. 1.2 Life Test Results Under Clean Lubrication Conditions

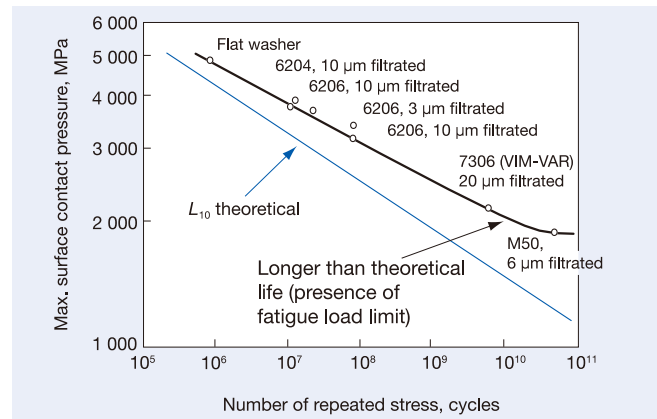

$$\ln \frac{1}{S} \propto N^e \int_V \frac{(\tau - \tau_u)^c}{Z_0^h} dV \dots (1)$$

(2) Surface-originated flaking

Under actual bearing operation, the lubricant is often contaminated with foreign debris such as metal chips, burrs, casting sand, and so on. When foreign particles are mixed in the lubricant, the particles become pressed onto the raceways by the rolling elements, and dents occur on the surfaces of the raceways and rolling elements. Stress concentrations occur at the edges of the dents, generating fine cracks that over time propagate into flaking of the raceways and rolling elements. As shown in Fig. 1.3, the actual life is shorter than conventionally calculated life when lubrication is contaminated at low maximum surface pressure. The line representing actual life separates from the line created by theoretical life calculations and moves towards a shorter life. This shows that decreasing maximum surface contact pressure has little effect on life under contaminated lubrication.

Fig. 1.3 Life Test Results Under Contaminated Lubrication Conditions

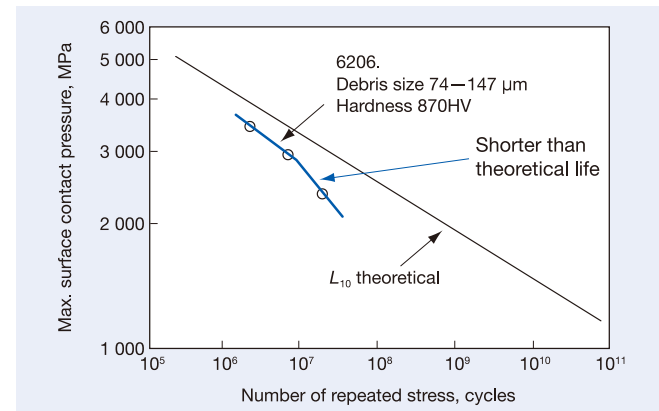

NSK's new life calculation formula accounts for trends in the results of the life test in a clean environment and at low load. Therefore, the new equation is a function of $(P - P_u)/C$. This function is affected by specific lubrication conditions identified by a lubrication parameter. In addition, it is assumed that the effects of different types and shapes of foreign particles are strongly influenced by the bearing load and lubrication conditions present and that such a relationship can be expressed as a function of the load parameter. This load parameter is defined in the new life calculation formula as $(P - P_u)/C \cdot 1/a_c$.

Based on the above concept, the calculation formula for surface-originated flaking is as follows:

$$\ln \frac{1}{S} \propto N^e \int_V \frac{(\tau - \tau_u)^c}{Z_0^h} dV \times \left\{ \frac{1}{f(a_c, a_L)} - 1 \right\} \dots (2)$$

Table 1.2 Value of Contamination factor a_c

a_c factor	Very clean	Clean	Normal	Contaminated	Heavily contaminated
	1	0.8	0.5	0.4-0.1	0.05
Application guide /Degree of filtration	<10 μm	10-30 μm	30-100 μm	Greater than 100 μm or no filtration (oil bath, circulating lubrication, etc.)	No filtration, presence of many fine particles
Application examples	Sealed, grease-lubricated bearings for electrical appliances, information technology equipment, etc.	Sealed, grease-lubricated bearings for electric motors Sealed, grease-lubricated bearings for railway axle boxes Bearings for machine tools, etc.	Normal usage Automotive hub unit bearings, etc.	Bearings for automotive transmission, industrial gearboxes; construction machines, etc.	—

(3) Calculation of contamination factor a_c

Test results on ball and roller bearings with grease lubrication and clean filtration show that bearing life is a number of times longer than the conventionally calculated life. However, hardness becomes a factor when foreign particles harder than HV350 enter the bearing, causing dents on the raceway. Fatigue damage from these dents can progress to flaking in a short time. Test results on ball and roller bearings with foreign particle contamination show from 1/3 to 1/10 of the conventionally calculated bearing life.

Based on these test results, we have adopted contamination factor a_c as a basic concept for NSK's new life theory. The contamination factor a_c is classified into five stages, as shown in Table 1.2.

(4) New Life Calculation Formula L_{able}

Combining the formulas for subsurface-originated flaking (1) and surface-originated flaking (2) yields a formula that can be expressed as:

$$\ln \frac{1}{S} \propto N^e \int_V \frac{(\tau - \tau_u)^c}{Z_0^h} dV \times \left\{ \frac{1}{f(a_c, a_L)} \right\} \dots (3)$$

From equation (3), equation (4) can be derived:

$$L_{able} = a_1 \cdot a_{NSK} \cdot L_{10} \dots (4)$$

Reliability factor a_1 is shown in Table 1.3. The theory also utilizes viscosity ratio K ($K = \nu / \nu_1$ where ν is the operational viscosity and ν_1 is the required viscosity). The lubrication parameter a_L is a function of K . The theory indicates that the better the lubrication conditions (the higher the K value), the longer the life.

As shown in equation (5), correction factor a_{NSK} is a function of lubrication parameter a_L and load parameter $(P - P_u)/C \cdot 1/a_c$.

$$a_{NSK} \propto F \left\{ \frac{P - P_u}{C} \cdot \frac{1}{a_c}, a_L \right\} \dots (5)$$

Figures 1.4 and 1.5 chart the correction factor a_{NSK} of the new life calculation formula as a function.

Table 1.3 Reliability Factor a_1

Reliability (%)	90	95	96	97	98	99
Reliability Factor	1.00	0.64	0.55	0.47	0.37	0.25

List of codes used:

- S : Probability that flaking does not occur after stress has been repeated N times
- N : Number of repeated stresses
- τ : Internal stress
- τ_u : Internal stress at fatigue limit
- V : Stress volume
- Z_0 : Depth at which maximum shear stress occurs
- a_c : Contamination factor
- a_L : Lubrication parameter (a function of viscosity ratio K)
- P : Load applied to bearing
- P_u : Fatigue load limit
- C : Basic dynamic load rating
- e, c, h : Constants

Fig. 1.4 New Life Calculation Graph for Ball Bearings

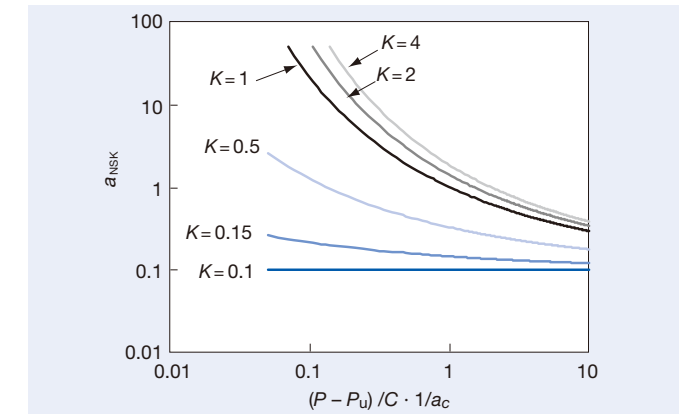
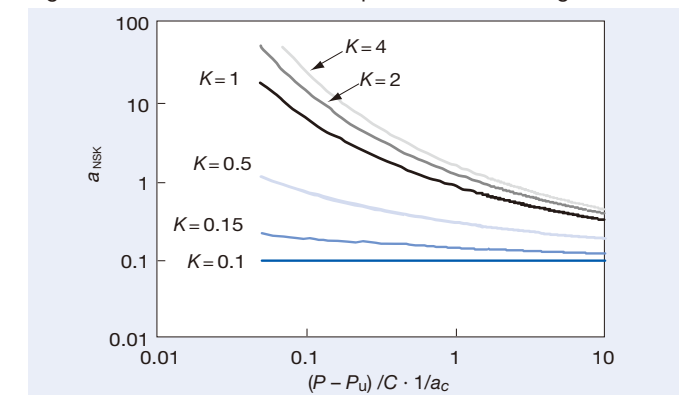

Fig. 1.5 New Life Calculation Graph for Roller Bearings



Features of Micro-UT™

NSK's Exclusive Material Evaluation Technology

NSK super precision bearings feature high-reliability steels with excellent cleanliness (see p. 14 for full details.) We developed exclusive technology to evaluate material cleanliness using methods such as Statistics of Extreme Value and have pushed to advance the quality control of rolling bearing steel since the 1990s. However, it remains difficult to predict life by numerically when flaking originates from non-metallic inclusions. In addition, there had been no commercially available method to detect microscopic inclusions that could lead to damage. Therefore, NSK developed Micro-UT: a unique ultrasonic technology to detect material flaws. As shown in Fig. 1.6 (a), Micro-UT allows us to quickly grasp the size and quantity of microscopic inclusions under 100 μm and obtain reliable statistical data about their distribution. NSK uses a proprietary method to process and assess Micro-UT data to maintain quality, thereby ensuring the high reliability of NSK bearings produced worldwide. Additionally, Micro-UT allows us to better quantify the high reliability of NSK bearings with more accurate life prediction.

Highly Accurate Life Prediction

Although using steel with high cleanliness can extend the flaking life of rolling bearings, there has been no way to accurately quantify this benefit. Therefore, we developed methods alongside Micro-UT to better predict flaking life using statistical data on the size and quantity of non-metallic inclusions in steel.

Three main factors influence flaking life: stress, material cleanliness, and material strength. NSK has developed the theoretical life equation below using parameters that account for these factors, establishing a method that accurately predicts the flaking life of NSK bearings supported by cleanliness data obtained with Micro-UT:

$$L = A \left[\frac{\tau}{\Delta K_{II} - \Delta K_{th}} \right]^B \left(\frac{C}{P} \right)^p \dots \dots \dots (6)$$

where A and B are empirical constants, τ is internal stress, and a parameter based on stress and defect size that is obtained from values given for the size of non-metallic inclusions and shear stress.

Figure 1.6 (b) compares predicted life from Equation (6) and data on the distribution of inclusions as obtained by Micro-UT with actual life from endurance tests. We can see that the life of NSK bearings far exceeds ISO predicted values, with our technology offering much more accurate predictions.

The basic dynamic load rating C of an NSK bearings is determined in accordance with in ISO 281:2007, but factors must be corrected to fully reflect the high reliability assured by our advanced technologies. With carefully selected, high-quality materials and processes, NSK bearings are your solution for reliability. NSK dynamic load ratings backed by our predictive technology can be found in Part 4 of this catalog and on our website.

Fig. 1.6 Example Micro-UT Data and Life Prediction Results

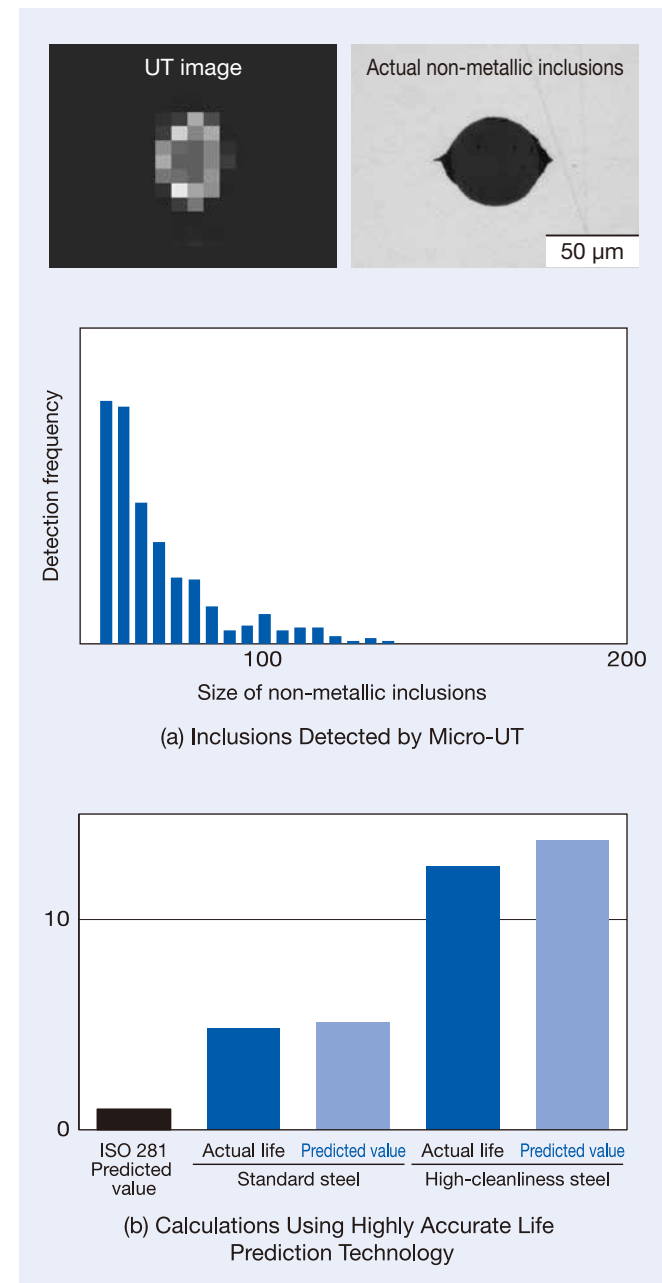

Life of High-Speed Bearings

When bearings are operated at high speed, the effect of centrifugal force acting on the rolling elements must be considered (Fig. 1.7). In the basic rating life equation on page 190, a ratio of basic dynamic load rating and external load was used, and the internal load generated by centrifugal force was not taken into account.

NSK employs specific software to perform convergence calculations that obtain a balance of the forces acting on rolling elements, including centrifugal force and various other elements. An example result of such a calculation regarding bearing life in high-speed operation is given in Fig. 1.8.

Please contact NSK for life calculations regarding bearings used in high-speed applications.

Note: Bearing life as mentioned above indicates rolling fatigue life, which does not include bearing failure caused by seizure, wear, or the like. It is difficult to calculate how long a bearing will perform until a bearing failure takes place. Please refer to page 190 for details on the definition of bearing life.

Life of Ceramic Ball Bearings

As ceramic balls have a lower density than steel balls, the increase in internal load due to centrifugal force in high-speed operation is less than with steel balls. Thus, the life calculation will show a longer life.

Fig. 1.7 Change in Contact Angle Due to Centrifugal Force

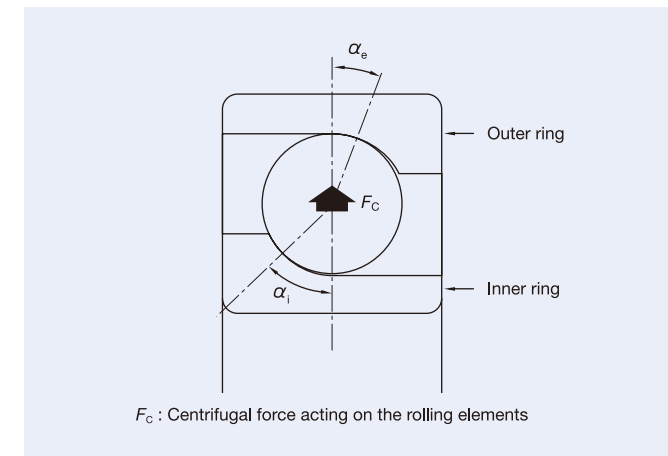
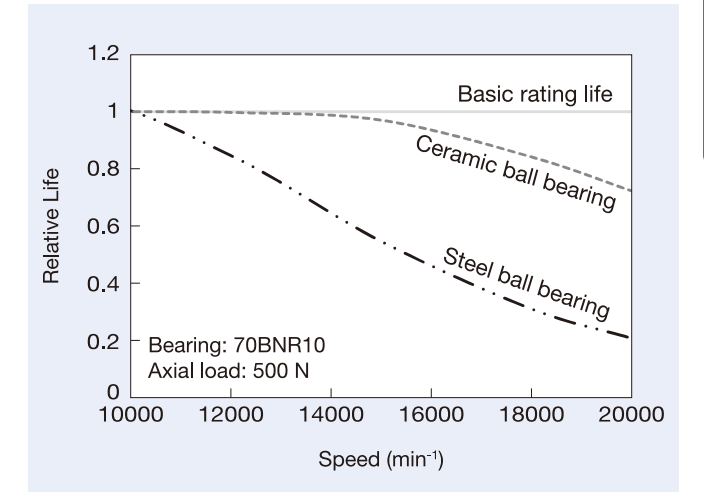

Fig. 1.8 Example Calculated Life Considering Centrifugal Force



Life Calculation for Multiple Bearings as a Group

When multiple rolling bearings are used in one machine, the fatigue life of individual bearings can be determined if the load acting on individual bearings is known. In general however, the machine becomes inoperative if a bearing in any part fails. It may therefore be necessary in certain cases to know the fatigue life of a group of bearings used in one machine.

The fatigue life of bearings varies greatly, and our fatigue life calculation equation $L_{10} = \left(\frac{C}{P} \right)^p$ (where $p=3$ for ball bearings and $p=\frac{10}{3}$ for roller bearings) applies to the 90% life, or “basic rating life”. This refers to either the number of revolutions or hours that 90% of bearings of the same type operated under the same conditions can reach.

In other words, the calculated fatigue life for one bearing has a probability of 90%. Since the endurance probability of a group of multiple bearings for a certain period is a product of the endurance probability of individual bearings for the same period, the basic rating life of a group of multiple bearings is not determined solely from the shortest basic rating life among the individual bearings. In fact, the group life is much shorter than the life of the bearing with the shortest fatigue life.

Defining the basic rating life of individual bearings as $L_1, L_2, L_3 \dots$ and the basic rating life of the entire group of bearings as L , the relationship may be expressed by the following equation:

$$L = \frac{1}{\left(\frac{1}{L_1^{1.1}} + \frac{1}{L_2^{1.1}} + \frac{1}{L_3^{1.1}} + \dots \right)^{1.1}}$$

Basic Static Load Rating

When subjected to an excessive load or a strong shock load, rolling bearings may incur a local, permanent deformation of the rolling elements and raceway surface. This deformation increases in area and depth as the load increases, and when the load exceeds a certain limit, the smooth running of the bearing is impeded.

The basic static load rating produces the following calculated contact stress at the center of the contact area between the raceway surface and the rolling element subjected to the maximum stress:

- for steel ball bearings : 4 200 Mpa
- for ceramic ball bearings : 4 600 Mpa
- for roller bearings : 4 000 Mpa

The basic static load rating value C_0 is listed in the bearing tables as C_{0r} for radial bearings and C_{0a} for thrust bearings.

The basic static load rating of multi-row bearing arrangements may be calculated using the following formula:

$$C_j = j \times C_1$$

where j : Number of rows

C_1 : Basic static load rating for a single-row bearing

C_j : Basic static load rating for a multi-row bearing

(where j refers to the number of rows)

However, when calculating the basic static load rating for thrust bearings C_{0a} , j refers only to the number of rows that sustain an axial load.

Steel ball bearings are specified by ISO 281 and hybrid bearings (ceramic ball bearings) by ISO 20056-2.

Static Equivalent Load

The static equivalent load is a hypothetical load that produces a contact stress equal to the maximum contact stress the bearing is subjected to under actual load conditions while stationary in the area of contact between the most heavily stressed rolling element and the bearing raceway.

For radial bearings, the radial load passing through the bearing center is used as the static equivalent load. For thrust bearings, the axial load in the direction coinciding with the central axis is used as the static equivalent load.

(a) Static equivalent loads for radial bearings

The greater of the two values calculated from the following equations should be adopted as the static equivalent load on radial bearings:

$$P_0 = X_0 F_r + Y_0 F_a \dots\dots\dots(1)$$

$$P_0 = F_r \dots\dots\dots(2)$$

where P_0 : Static equivalent load (N)

F_r : Radial load (N)

F_a : Axial load (N)

X_0 : Static radial load factor

Y_0 : Static axial load factor

(b) Static equivalent loads for thrust bearings

$$P_0 = X_0 F_r + F_a \quad \alpha \neq 90^\circ \dots\dots\dots(3)$$

where P_0 : Static equivalent load (N)

α : Nominal contact angle

Note that the accuracy of this equation decreases when

$F_a < X_0 F_r$.

The values X_0 and Y_0 of equations (1) and (3) are shown in Table 2.1.

Note that $P_0 = F_a$ for thrust bearings with $\alpha = 90^\circ$.

Table 2.1 Static Equivalent Loads

Bearing type		Single row		Double row	
		X_0	Y_0	X_0	Y_0
Angular contact ball bearings	$\alpha = 15^\circ$	0.5	0.46	1	0.92
	$\alpha = 18^\circ$	0.5	0.46	1	0.92
	$\alpha = 25^\circ$	0.5	0.38	1	0.76
	$\alpha = 30^\circ$	0.5	0.33	1	0.66
Tapered roller bearings	$\alpha \neq 0$	0.5	$0.22 \cot \alpha$	1	$0.44 \cot \alpha$
Cylindrical roller bearings	$\alpha = 0$	$P_0 = F_r$			
Thrust ball bearings	$\alpha = 90^\circ$	$P_{0a} = F_a$			
Thrust roller bearings	$\alpha = 90^\circ$	$P_{0a} = F_a$			
Thrust ball bearings	$\alpha \neq 90^\circ$	$P_{0a} = F_a + 2.3 F_r \tan \alpha$			
Thrust roller bearings	$\alpha \neq 90^\circ$	$(\text{where } F_a > 2.3 F_r \tan \alpha)$			

Permissible Static Load Factor

The permissible static equivalent load on bearings varies depending on their basic static load rating, their application, and operating conditions. The permissible static load factor f_s is a safety factor that is applied to the basic static load rating, and it is defined by the ratio in the equation below:

$$f_s = (C_0/P_0)$$

where C_0 : Basic static load rating

P_0 : Static equivalent load

Table 2.2 lists the generally recommended values for the permissible static load factor f_s .

Table 2.2 Values of Permissible Static Load Factor f_s

Operating conditions	Lower limit of f_s	
	Ball bearings	Roller bearings
Low-noise applications	2.0	3.0
Bearings subjected to vibration and shock loads	1.5	2.0
Standard operating conditions	1.0	1.5

Permissible Axial Load for Angular Contact Ball Bearings

Ball Bearings

NSK has defined the limiting static axial load as the smaller of the two values listed below:

1. Limiting axial load that produces shoulder override

The limiting load at which the contact ellipse generated between the ball and the raceway overrides the shoulder of the raceway groove (Fig. 2.1)

2. Limiting axial load in terms of surface pressure

The limiting load at which the contact stress at the center of the contact area between the ball and the raceway groove reaches a level that leaves an indentation as defined in the basic static load rating (Fig. 2.2)

To maintain optimal bearing performance, NSK has defined permissible static axial load values by applying a safety factor to the limiting axial load based on many years of experience.

The formula for calculating the basic static axial load rating C_{0a} does not take the shoulder height of the raceway groove into account. Therefore, in some cases the C_{0a} value may exceed the limiting axial load that produces shoulder override. In such cases, the maximum load that the bearing can sustain is lower than the C_{0a} value, making the C_{0a} value unsuitable (Fig. 2.3). Therefore, instead of C_{0a} values, we have listed limiting axial load values in the bearing tables where necessary, particularly for angular contact thrust ball bearings as they are usually used to support heavy axial loads.

Fig. 2.1 Limiting Axial Load that Produces Shoulder Override

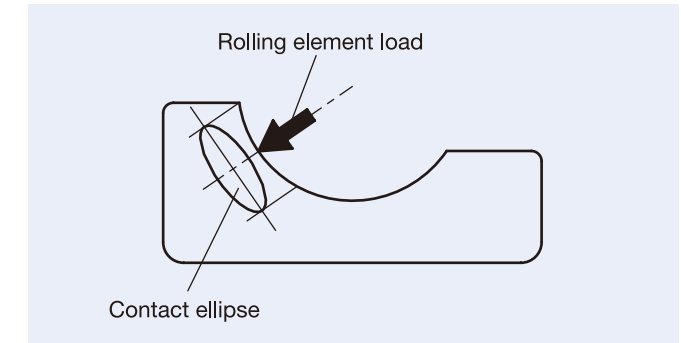

Fig. 2.2 Limiting Axial Load in Terms of Surface Pressure

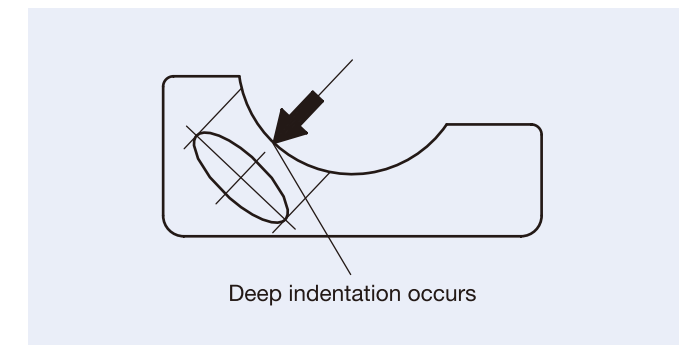
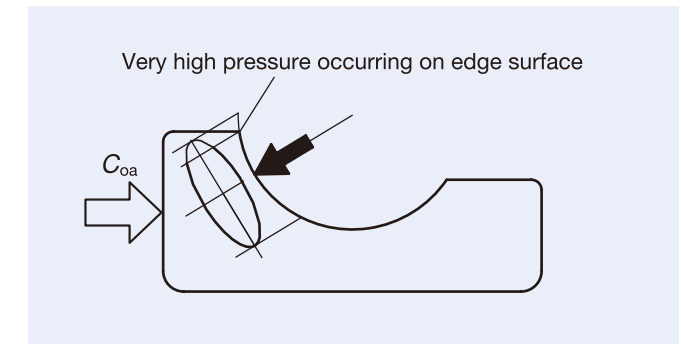

Fig. 2.3 C_{0a} and Limiting Axial Load



Angular Contact Ball Bearing Combinations

The combinations of angular contact ball bearings used for the fixed end of spindles are usually 2 row (DB), 3 row (DBD), and 4 row (DBB) sets. However, in 3 row combinations the preload is unevenly distributed between the bearings, resulting in a very limited optimum range of preload which makes them unsuitable for high-speed applications.

Matched bearings are manufactured as sets, so when they are mounted adjacent to each other, the specified preload is automatically achieved. The variation of bore and outside diameter within each set of matched bearings is adjusted to less than 1/3 of the permissible tolerance.

Table 3.1 Features of Each Combination

	DB	DF	DT	DBD	DBB
Load direction	↔	↔	→	↔	↔
Moment stiffness	◎	○	△	◎	◎
Speed capability	◎	◎	◎	△	○
Low heat generation	◎	◎	◎	△	○
Stiffness	○	○	△	◎	◎

◎Excellent ◎Very good ○Good △Fair →One direction only ↔Two directions

Features of Each Combination

● Back-to-back Arrangement, DB

Axial loads in both directions and radial loads can be sustained. Since the distance between the effective load centers is large, this type is suitable if moments are applied. However, in case of insufficient housing accuracy or shaft misalignment, internal load of the bearings could be large enough to possibly cause premature failure due to the high level of moment stiffness.

● Face-to-face Arrangement, DF

Compared with the DB type, the distance between the effective load centers is small, so the capacity to sustain moments is inferior to the DB type. On the other hand, this type is suitable for use with housings that have less accuracy or larger shaft deflections due to low bending stiffness of the shaft.

● Tandem Arrangement, DT

Axial loads in one direction and combined loads can be sustained. Since axial stiffness of this type is twice the value of a single row type, this arrangement is used when the axial load in one direction is heavy.

If preload is required, it needs to be applied externally, e.g. by using a spring.

● 3 Row Arrangement, DBD

Axial loads in both directions and radial loads can be sustained. However, the preload distribution to each bearing is not equal, and preload on the counter side (single side) is twice that of the other side. Consequently, this type is unsuitable for high-speed operation because of the large increase of internal load on the single side, which could lead to bearing failure.

● 4 Row Arrangement, DBB

Axial loads in both directions and radial loads can be sustained. In situations that have the same axial clearance

as DB arrangement, preload and stiffness are twice that of the DB arrangement. Also, the permissible axial load of a 4 row arrangement is larger than that of a DB arrangement.

Fig. 3.1 The Distance between the Effective Load Centers of Back-to-back and Face-to-face Arrangements

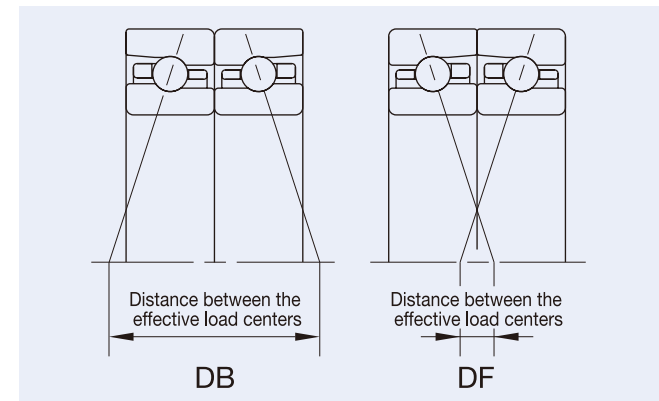

Fig. 3.2 Load Application Direction in Back-to-back and Tandem Arrangements

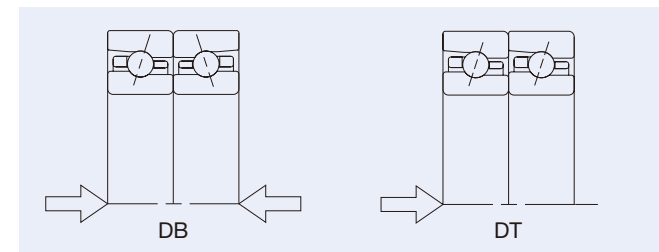
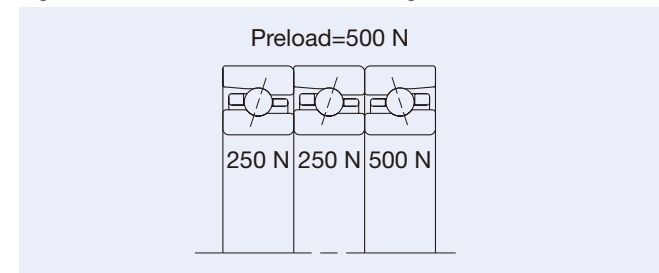

Fig. 3.3 Internal Preload in DBD Arrangement



Shaft Bending Comparison between Back-to-back and Face-to-face Arrangements

Moment stiffness is different between back-to-back and face-to-face arrangements. We have calculated typical shaft deflections for the spindle structure shown in Fig. 3.4. In this example, angular contact ball bearings (75BNR10XET) are used at the front end and shaft deflections are shown for both DB and DF configurations. A radial load of 1 000 N applied to the spindle nose will cause the following radial deflection of the spindle nose:

$$\sigma_{DB} = 2.4079 \times 10^{-2} \text{ (mm)}$$

$$\sigma_{DF} = 2.9853 \times 10^{-2} \text{ (mm)}$$

This demonstrates the effect the distance between effective load centers has on spindle bending.

Mounting Instructions for Matched Angular Contact Ball Bearings

Direction of Matching

For matched bearings, the mounting order and load application direction are very important. As shown in Fig. 3.6, marks on the outer ring surfaces of the bearings form a "V" when the bearings are properly matched and aligned.

Radial Run-out Mark

On the side surface or chamfered part of the inner rings, the symbol "○" is marked to indicate the position of maximum radial run-out. Optimum accuracy is achieved when the bearing is mounted so the "○" symbol is placed directly opposite the point of maximum shaft eccentricity.

Fig. 3.5 The Symbol for the Position of Maximum Radial Runout of the Inner Ring

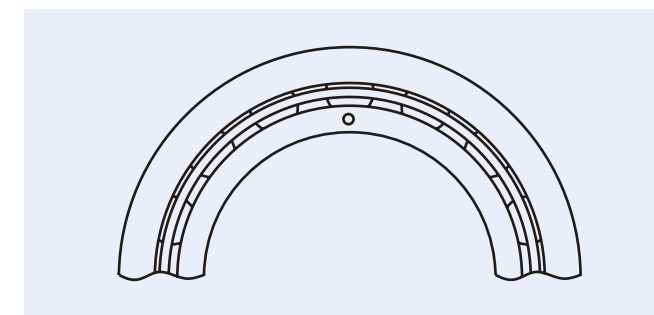

Fig. 3.4 Spindle Deflection Curve

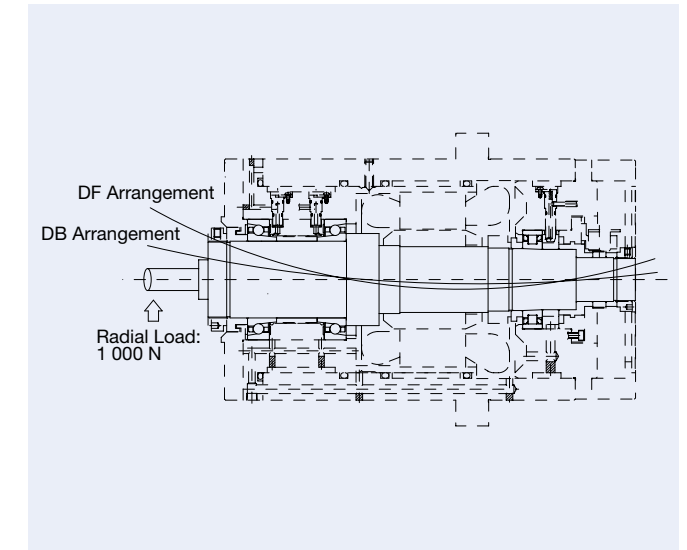
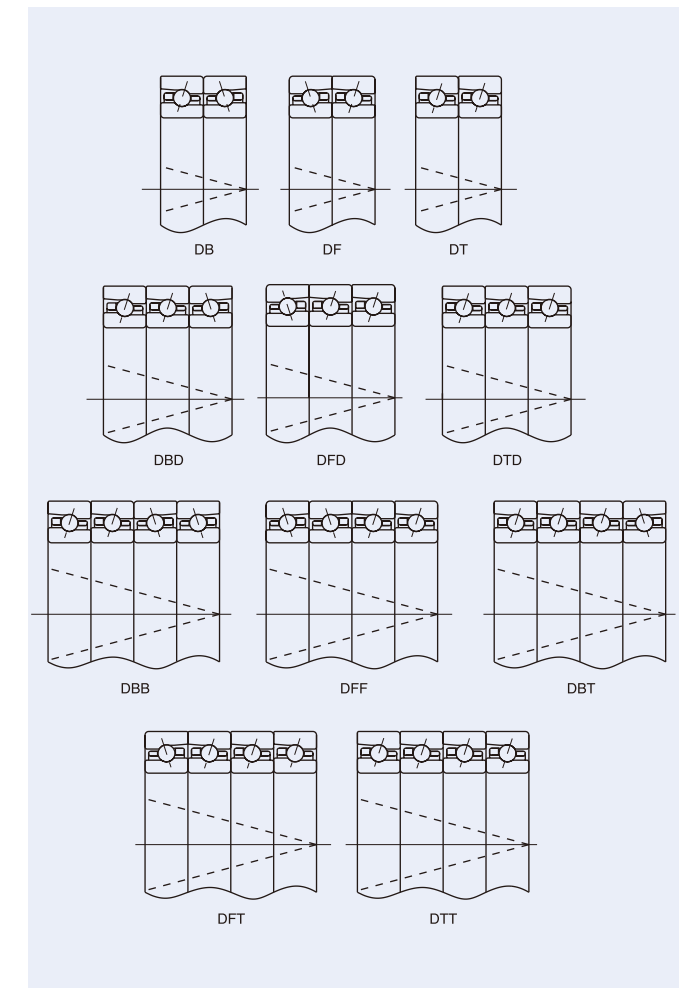

Fig. 3.6 Combinations of Angular Contact Ball Bearings



3. Angular Contact Ball Bearing Combinations

Important Points to Consider When Using Matched Bearings

The axial clearance (stand-out) of each bearing in a set of matched bearings (DB, DT, DFD etc.) has been adjusted and controlled, so that the specified amount for each standard preload is achieved when the bearings are arranged in the order indicated by the marks on the surface of their outer rings. These marks form a “V” when the bearings have been correctly mounted. Thus, as long as the bearing direction and the order of the bearings are not altered, bearing axial clearance or preload gap is controlled even if some bearings are selected from a bearing set. In this case the marks on the outer rings will also form continuous straight lines.

Should the direction or order of matched bearings be changed, the clearance adjustment of mating surfaces will be lost and the resulting clearance values will be unknown. If used this way, problems may arise due to excessive or insufficient preload and uneven load distribution. Therefore, in order to use matched bearings in other than the prescribed directions and order, it is necessary to measure the stand-out (offset) of each individual bearing and use spacers to adjust the axial clearance according to these measurements.

We do not recommend machining the bearings themselves to the desired offset, as debris from grinding may remain inside the bearing.

To customers who wish to use the same bearings on various machines, we recommend stocking universal arrangement bearings rather than sets of matched bearings prepared for specific arrangements. Universal arrangement bearings are ready for use in different arrangements. For more information on universal arrangement bearings, please refer to page 204.

Fig. 3.7 DT Combination

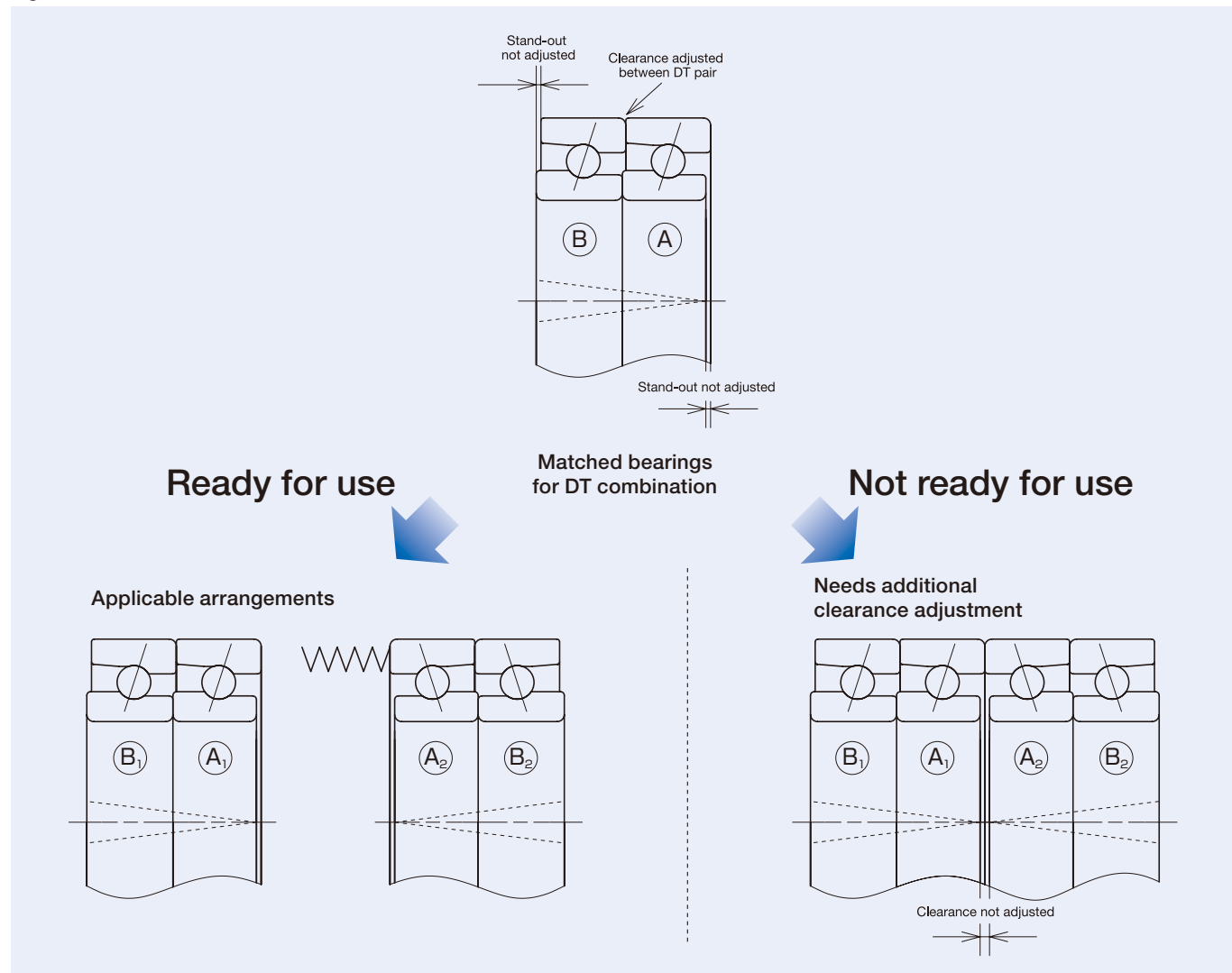
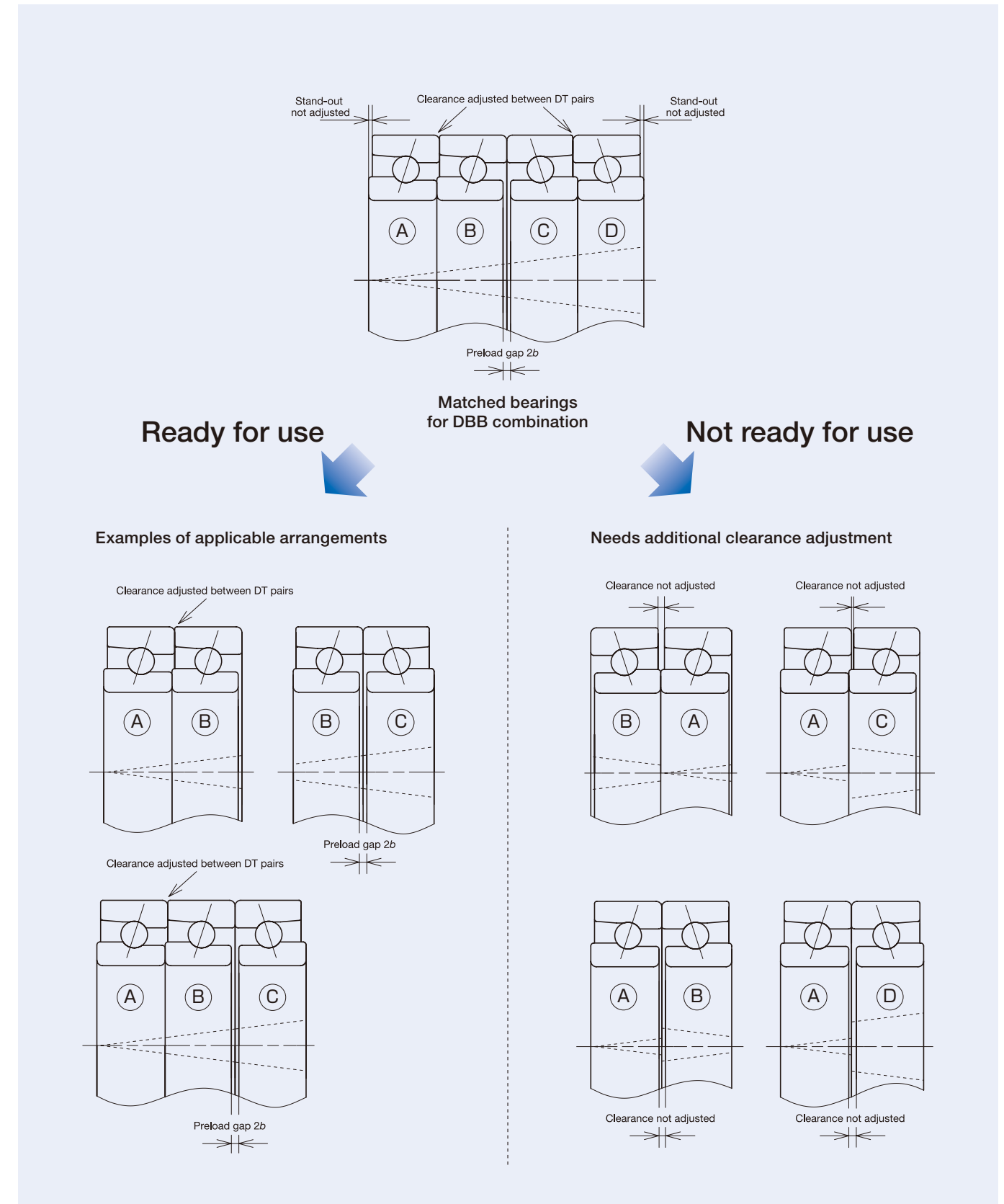

Fig. 3.8 DBB Combination



Universal Arrangement Bearings

NSK manufactures universal arrangement bearings which have been controlled to have the same amount of stand-out (offset) on their front and back faces. That way, for bearings with the same designation, users will achieve the specified amount for each standard preload, regardless of which combination they chose. Each universal arrangement bearing comes with a V-shaped mark on the surface of the outer ring to simplify identification of the correct direction when mounting and to ensure that the correct combination is achieved. The V-shaped mark points to the direction of the axial load that the inner ring supports (contact angle).

Fig. 3.9 Universal Arrangement

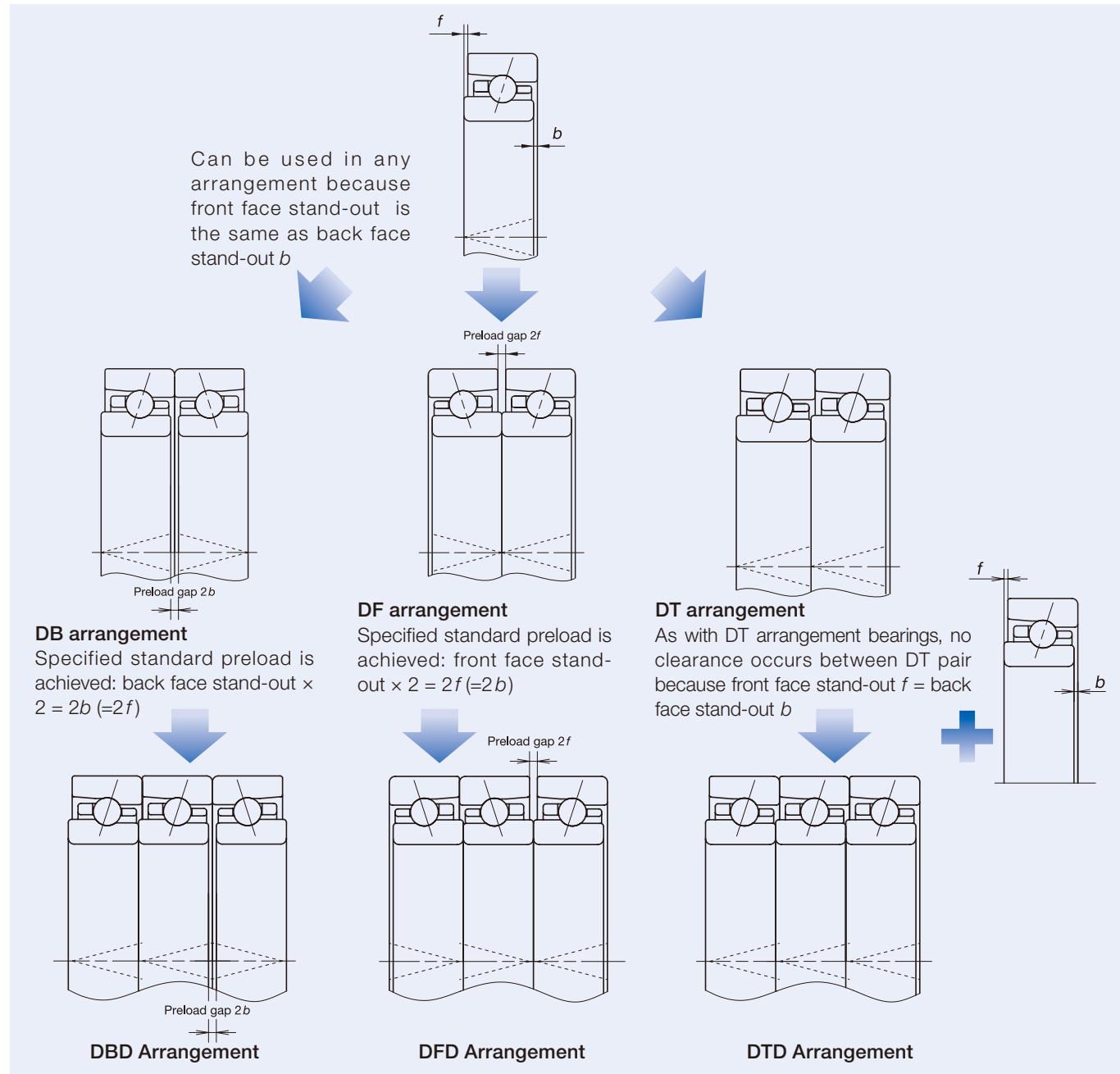

Types of Universal Arrangement Bearings

NSK supplies four types of universal arrangement bearings, as shown in Table 3.2. Variation of bore and outside diameter are controlled for multiple-row universal arrangement bearings.

Table 3.2 Types of Universal arrangement Bearings and Their Features

	SU	DU	DUD	QU
Number of rows	1	2	3	4
Variation of bore and outside diameter	—	Controlled to be within 1/3 of tolerance		

Note: Variation control for P4Y class bearings is the same as for P4 class bearings.

Notice for the Use of Single Universal (SU) Bearings

- In the case of bearing sets (DB, DU etc.), the variations of bore and outside diameter within each set are controlled. However, when using single row universal arrangement bearings (SU), users should check the actual bore/outside diameter variation printed on the box of each bearing and make sure variation of these dimensions is low. Otherwise variations in housing or shaft fit may occur that result in imbalances of internal load, which may cause damage to the bearings.
- One way of keeping the variation of bore and outside diameter of SU bearings low is to choose the P4Y accuracy class that NSK provides. P4Y rated bearings have a running accuracy of ISO Class 4. As bore diameter and outside diameter are strictly controlled, these bearings are suitable for custom matching.

Fig. 3.10 Tolerances of P4 and P4Y Accuracy

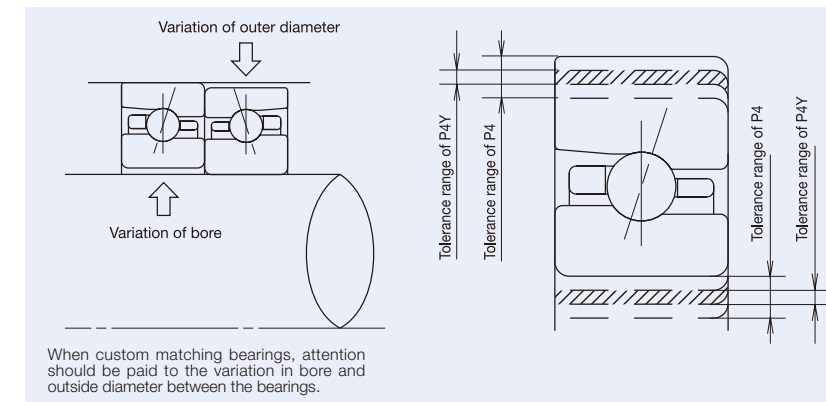
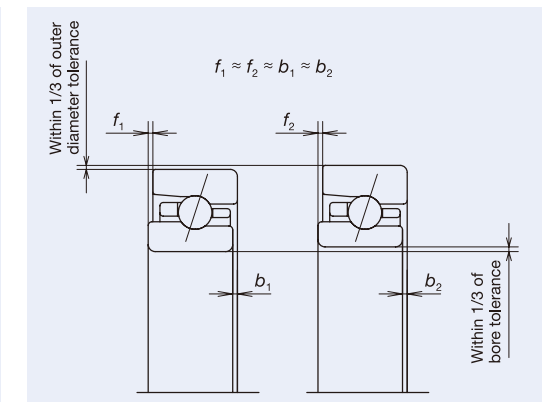
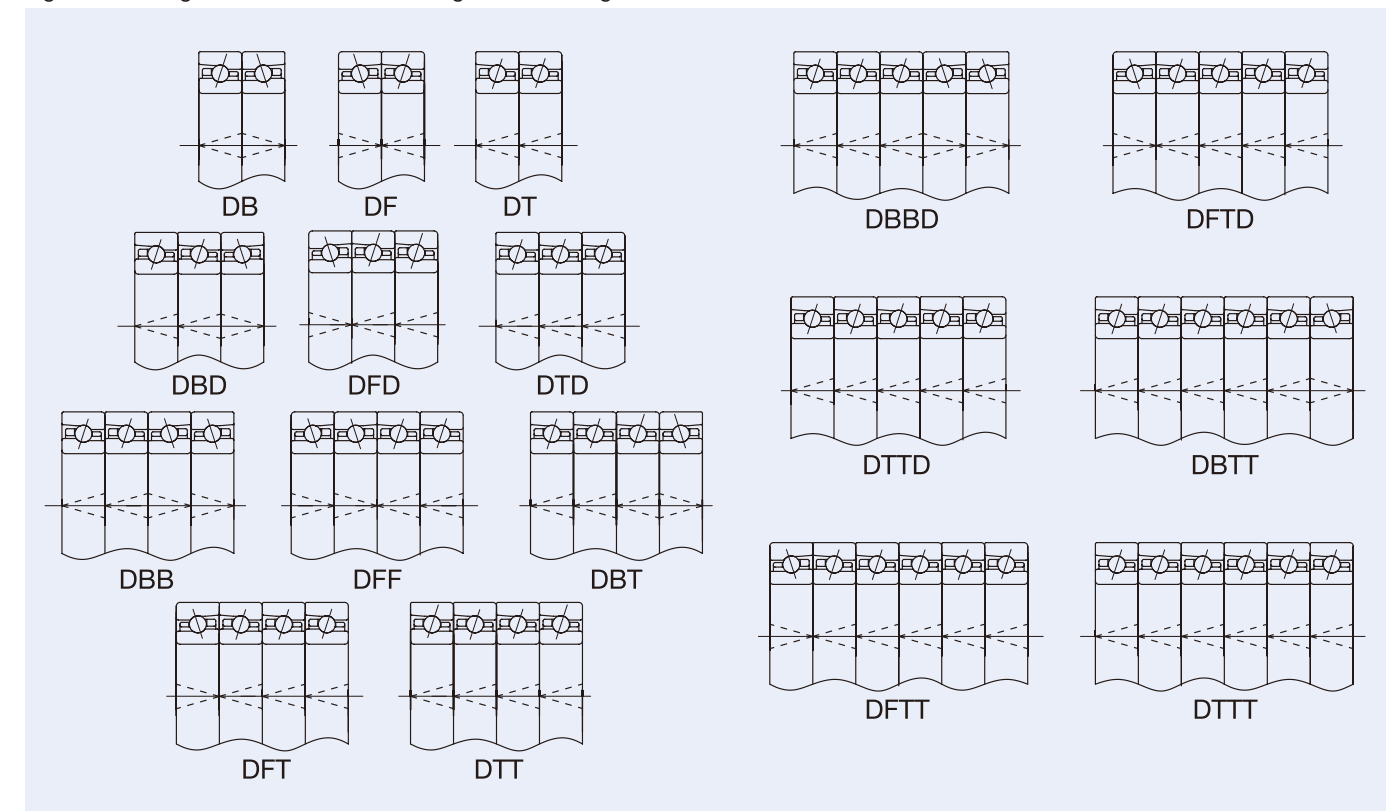

Fig. 3.11 DU Combination



Combination Mark and Matching Method for Universal Arrangement Bearings

Fig. 3.12 Arrangements of Universal arrangement Bearings



Regarding the rigidity of machine tool spindles, it is possible to think of the bearings as being springs. When an axial load is applied to the spindle, axial displacement of the spindle is determined by the axial rigidity of the fixed end bearings.

Radial loads applied to the spindle end will cause radial deflection. While shaft deformation will account for most of this deflection, bearing deflection is also a factor that may not be ignored.

When high radial rigidity is required, cylindrical roller bearings are generally used. In this case, axial loads are usually sustained by angular contact thrust ball bearings. The bigger the contact angle of an angular contact ball bearing, the higher its axial rigidity.

Normally, preload is applied to bearings in order to increase the rigidity of machine tool spindles. However, excessively high preload may cause seizure and flaking. Many users increase rigidity by using a combination of two or more angular contact ball bearings. This is especially true for ball screw support bearings, where high rigidity is required, contact angle is as large as possible, and preload is higher than that for a spindle.

Purpose

The main purposes of applying preload to bearings in machine tool spindles are as follows:

- To improve the running accuracy of the spindle.
- To increase spindle rigidity.
- To minimize noise due to spindle vibration.
- To prevent abnormal wear due to oscillation and vibration
- To prevent sliding between the rolling elements and raceways

Usually a preload is applied to bearings by using two or more bearings in combination, such as angular contact ball bearings or tapered roller bearings. Cylindrical roller bearings can be preloaded by making the radial internal clearance negative.

(1) Position Preload

A position preload is achieved by fixing two axially opposed bearings so that their position relative to one another remains unchanged during operation. In practice, the following three methods are generally used to obtain a position preload.

1. By using a spacer or shim of proper size to obtain the required spacing and preload, as shown in Fig. 4.1(a) on the left, (b) and (c).
2. By installing a bearing set with previously adjusted stand-out dimensions and axial clearance, as shown in Fig. 4.1(a) on the right.
3. By utilizing bolts or nuts to allow adjustment of axial preload, as shown in Fig. 4.1(d). In this case, starting torque should be measured to verify proper preload. However, this method cannot be recommended for high precision machine tool spindles due to difficulty in verifying the proper preload, thus risking vertical displacement (tilting) of the bearing.

Fig 4.1 Position Preload Examples

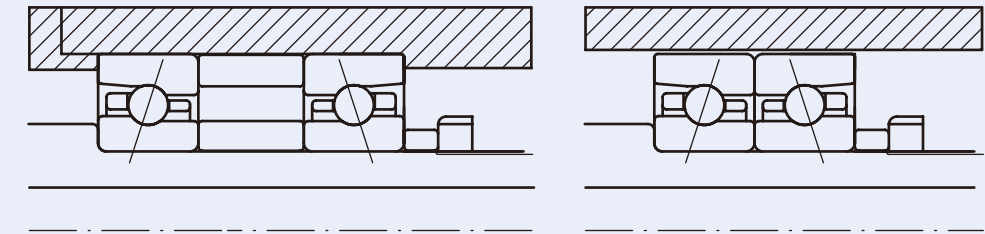

(a) Angular contact ball bearings in position preload

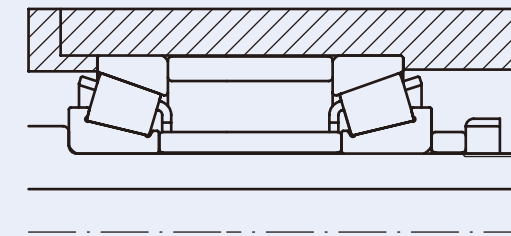

(b) Tapered roller bearings in position preload

Note: The cages of tapered roller bearings usually protrude from the bearing's end faces. Customers who wish to reduce bearing span, please bear in mind the required minimum amount of spacer width.

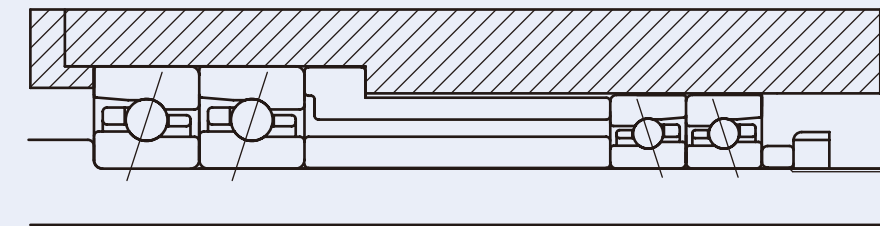

(c) Bearing combinations of differently sized bearings in position preload

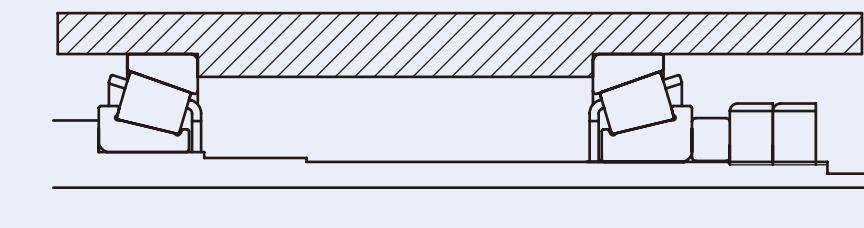

(d) Position preload without spacers

Axial Load and Displacement in Position Preload (DB Arrangement)

Fig 4.2 illustrates the mechanism of preload and axial load in bearing combinations.

Fig 4.2 Axial Displacement in Position Preload (DB Arrangement)

(1) When the inner rings are fixed axially, bearings A and B are displaced by δ_{a0A} and δ_{a0B} , respectively. Thus, the axial clearance (preload gap) δ_{a0} between the inner rings is eliminated. In this condition, preload F_{a0} is imposed on each bearing.

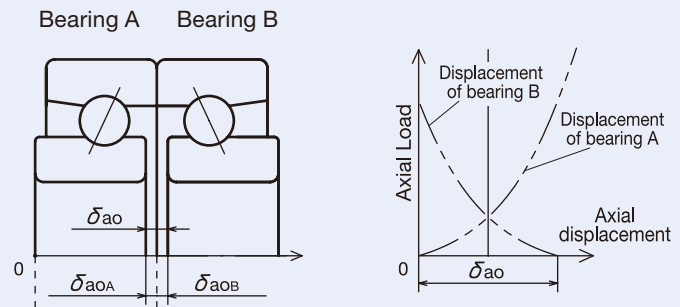

(2) When an axial load F_a is applied to the preloaded bearing combination as shown, the inner ring of bearing A will be displaced by δ_a . A balance between the loads acting on each bearing will be achieved in the point where the amount of displacement of bearing A equals that of bearing B.

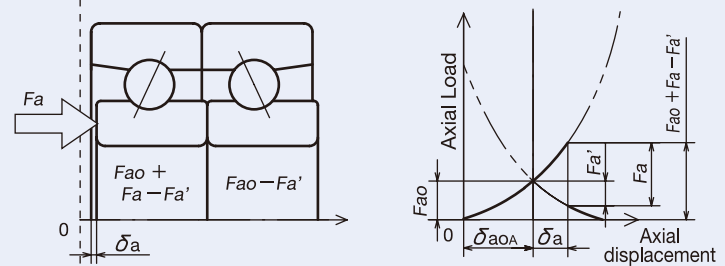

(3) When a large axial load is applied so that the displacement of the inner ring of bearing B exceeds δ_{a0B} , bearing B will no longer sustain axial load. Axial load will be sustained by bearing A only. Therefore axial rigidity will decrease.

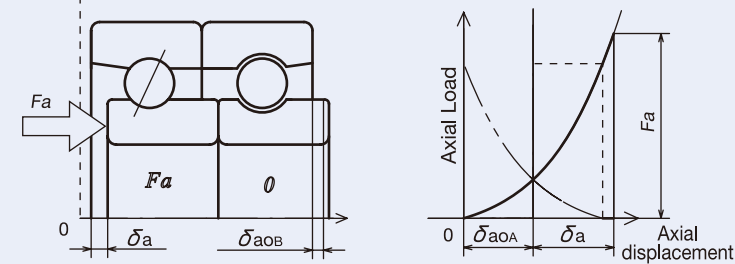

Axial Load and Displacement in Position Preload (DBD Arrangement)

In DBD arrangements, one direction of axial load is divided equally between two bearings. Apart from that the basic concept is the same as with DB arrangements (shown in Fig 4.2.)

Fig 4.3 Axial Displacement in Position Preload (DBD Arrangement)

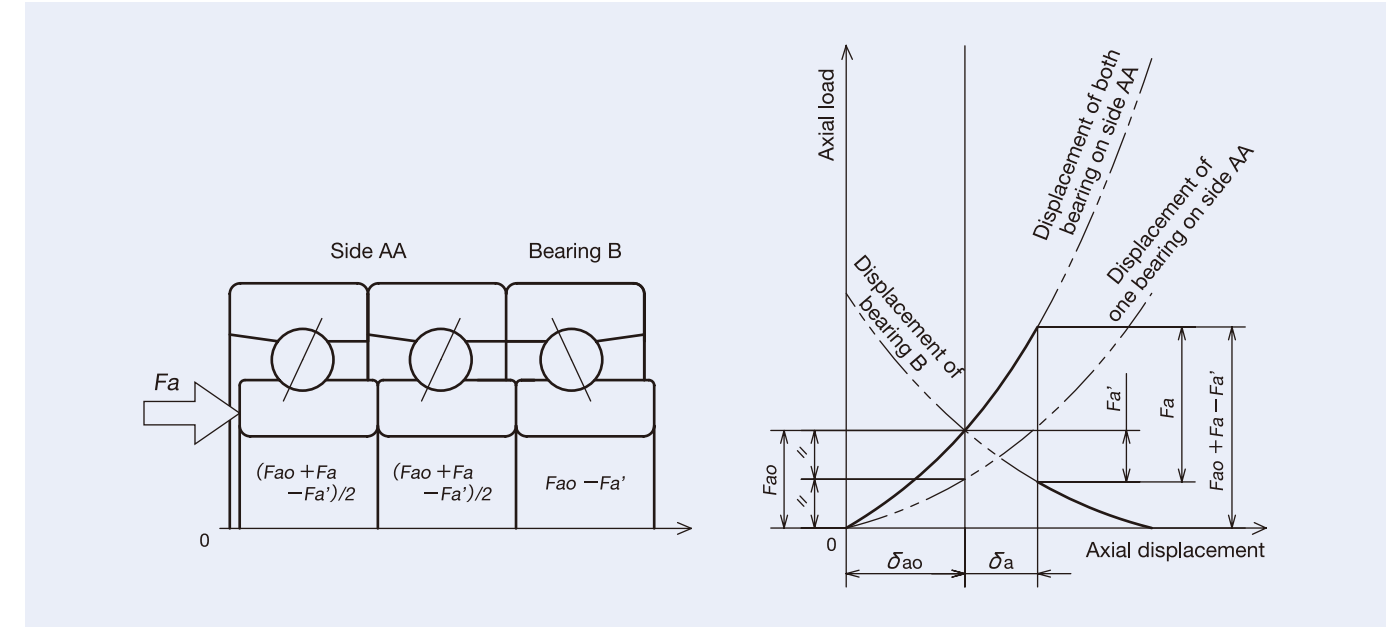

Preload Loss

As Fig 4.2 (3) shows, when a preloaded bearing arrangement receives a large axial load, the bearing on the opposite side becomes unloaded. This can cause sliding between the rolling elements and raceways, and may cause excessive wear or bearing damage under high-speed rotation.

When angular contact ball bearings of the same type are used in an arrangement, preload loss will occur when a load 3 times the preload of a single DB or DF arrangement is applied. For tapered roller bearings, this loss-causing load is 2 times the preload of a single DB or DF arrangement. Preload loss factors for angular contact ball bearings and example calculations are shown below.

Table 4.1 Approximate Values for Load Causing Preload Loss

Combination	Arrangement code	Direction of force	Preload loss (multiply with preload of DB/DF arrangements)
	DB		3
			3
	DBD		6
			3
	DBB		6
			6
	DBT		9
			3
	DBBD		9
			6

Example calculations of preload loss for 7014A5TYNDBD with L preload:
Preload for DB/DF arrangements: 500 N
(See Page 79.)

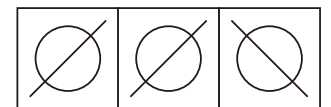

Direction of force	Load causing preload loss
	$500 \times 6 = 3\ 000\text{N}$
	$500 \times 3 = 1\ 500\text{N}$

Standard Clearance

NSK supplies matched angular contact ball bearings in four standard preload classes:

EL: Extra light preload L: Light preload
M: Medium preload H: Heavy preload

In addition, two special clearances are available for matched angular contact ball bearings and for tapered roller bearings:

CA: Special Measured (+) Axial Clearance
CP: Special Measured (-) Axial Clearance
...(preload is generated)

Fig 4.4 Special Clearances

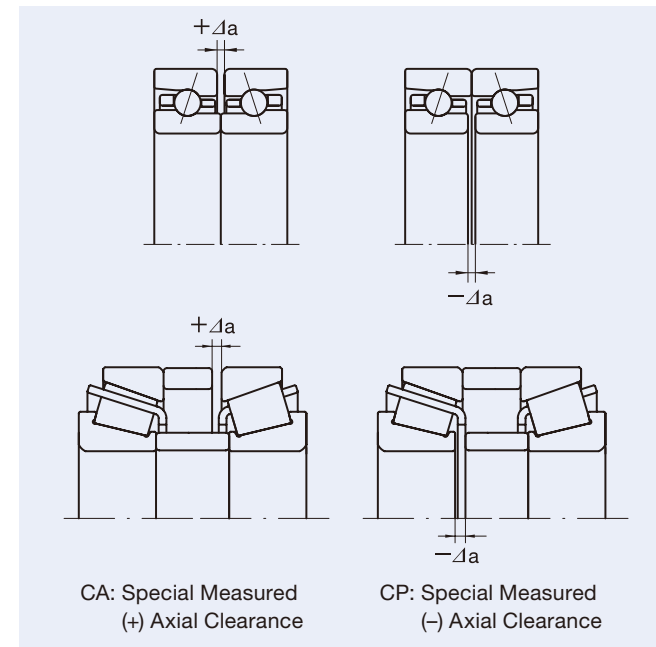

Preload Adjustment with Spacers

The measured axial clearance of each bearing is listed in the bearing tables in Part 4 of this catalogue. The listed values refer to DB and DF arrangements and do not include the influence of shaft and housing fit or nut clamping force.

When using spacers to adjust the preload (for example L → EL, L → M etc.), adjust the difference between measured axial clearance and target clearance value with a spacer. With DB arrangement, reduce the width of the inner-ring spacer to increase preload, and reduce the width of the outer-ring spacer to decrease preload.

In the case of universal arrangement bearings, the following applies:

When using a DB combination, the amount of axial clearance between the bearings equals the sum of the back face stand-out values of each bearing.

In a DF combination, the amount of axial clearance between the bearings equals the sum of the front face stand-out values.

Please adjust the difference to your required axial clearance with spacers. Table 4.2 shows measuring loads for measuring axial clearance. The values in the table indicate the amount of load necessary to obtain stable measurements.

Fig 4.5 Adjustment of Axial Clearance with Spacers

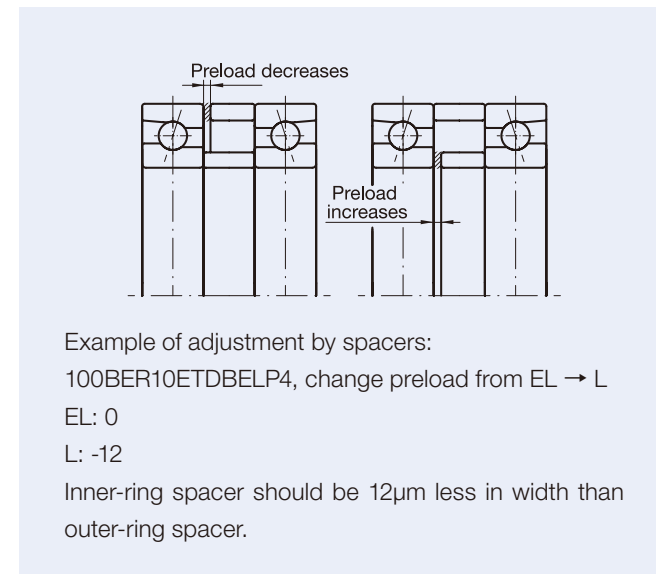

Table 4.2 Measuring Loads for Axial Clearance Measurement

Nominal bearing outside diameter D (mm)		Measuring load (N)
Larger than	Up to	
10 (*)	50	24.5
50	120	49
120	200	98
200	400	196

(*) Outside diameter of 10mm is included in this range

Measuring Axial Clearance of Angular Contact Ball Bearing Combinations

In the case of a DB arrangement, place the bearing without the inner-ring spacer on the cradle as described in the figure below; then apply the measuring load to the inner ring. After the bearing is sufficiently stabilized, set the dial gauge to zero.

Next, after removing the outer-ring spacer, place the bearing with the inner-ring spacer on the cradle and apply measuring load in the same way as described above. The reading on the dial gauge now indicates the axial clearance. A positive reading signifies a CA clearance (positive clearance in axial direction). A negative reading signifies a CP clearance, which generates preload.

The axial clearance of a DF arrangement is measured in the same manner as with a DB arrangement, although the positions of spacers and cradles are different.

With a DT arrangement, the sum of front face stand-out and back face stand-out of the combined bearings at the mating surfaces should be zero.

For single-row bearings, axial clearance of a double-row arrangement can be obtained by adding the measured values of each bearing.

DB Arrangement

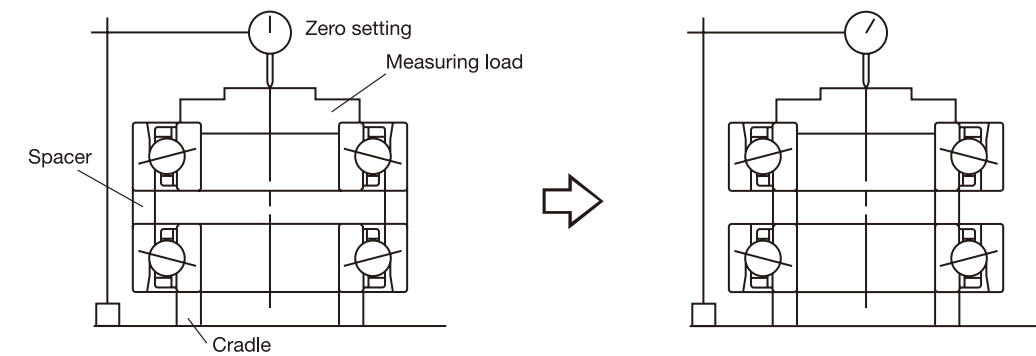

DF Arrangement

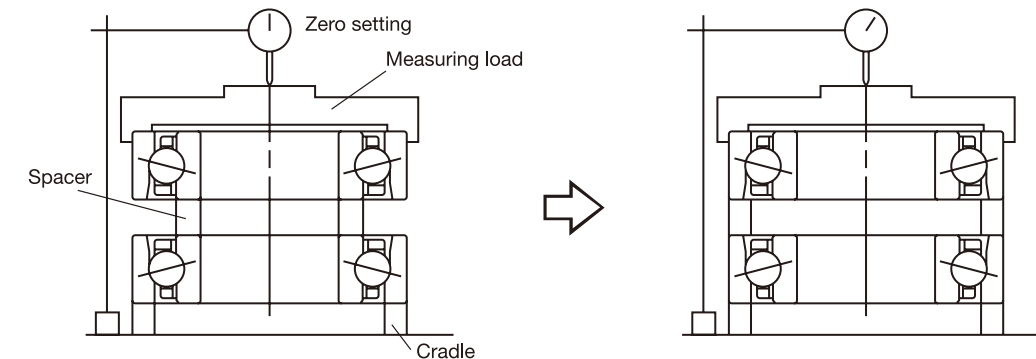

Single Row

Back face stand-out

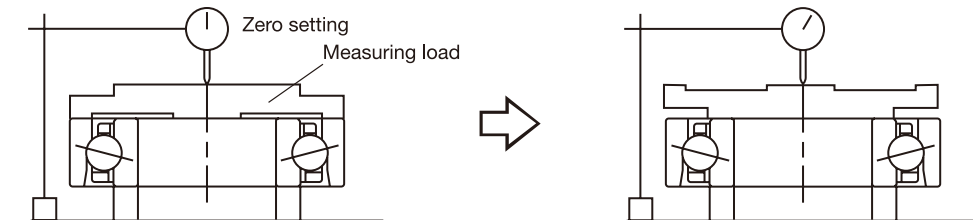

Front face stand-out

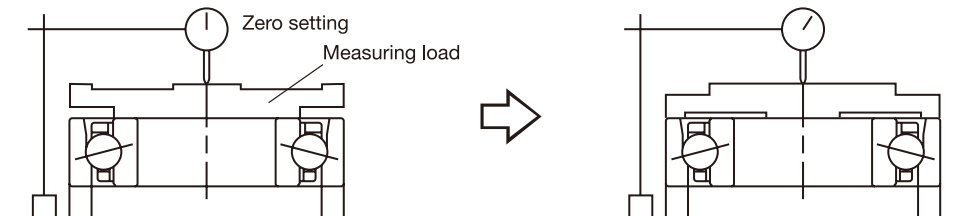

Measuring Axial Clearance of Tapered Roller Bearing Combinations (Stand-out Measuring Method)

In the case of a DB arrangement, place a single row bearing on a cradle with the back face of the inner ring facing down. Turn the outer ring (at least 10 turns) to stabilize the rollers. Then measure inner ring width and assembled bearing width. Next, measure the inner ring width and assembled bearing width of the second bearing in the same way. Finally, measure widths K and L of the spacers.

Inserting these measurements into the equation below will obtain axial clearance Δ_a .

$$\Delta_a = (L-K) - (f_A + f_B) = (L-K) - [(T_A - B_A) + (T_B - B_B)]$$

$\Delta_a < 0$ signifies a preload.

In the case of a DF arrangement, measure the outer ring instead of the inner ring. This gives the following equation for axial clearance:

$$\Delta_a = (K-L) - (b_A + b_B) = (K-L) - [(T_A - C_A) + (T_B - C_B)]$$

Tapered rolling bearings in DF arrangement are often operated without the use of an inner-ring spacer, so that the inner rings of both bearings touch directly. In this case, $L = 0$.

Since the cages protrude, please make sure you place the bearings with the correct side onto the cradle when measuring tapered roller bearings and take care to avoid mechanical interaction with other parts so as to prevent cage deformation.

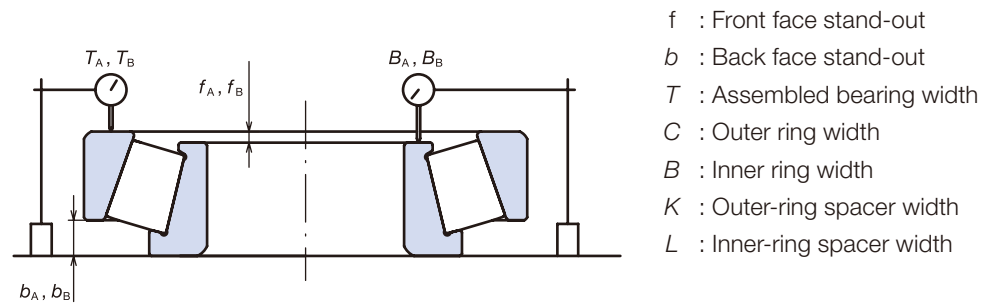
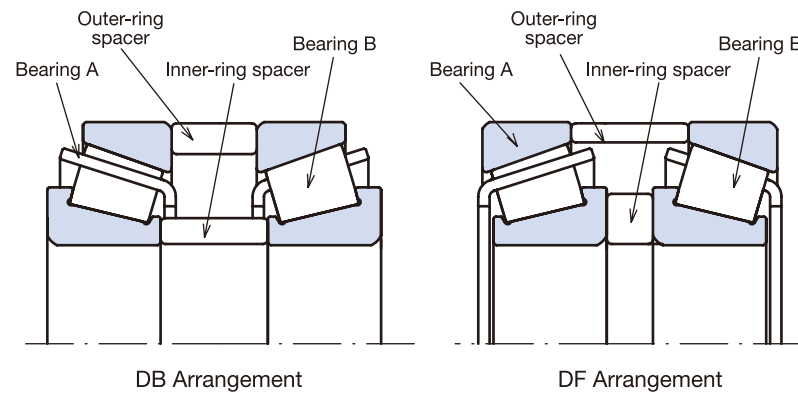

- f : Front face stand-out
- b : Back face stand-out
- T : Assembled bearing width
- C : Outer ring width
- B : Inner ring width
- K : Outer-ring spacer width
- L : Inner-ring spacer width

(2) Constant Pressure Preload

Constant pressure preload is achieved using a coil or disc spring. Even if the relative position of the bearings changes during operation, the magnitude of the preload remains relatively constant throughout all the various operation conditions. Therefore constant pressure preload is used for combinations of angular contact ball bearings in high-speed applications.

One example is shown in Fig. 4.6. Since spring rigidity is, as a rule, small compared with bearing rigidity, the change in spring preload due to bearing displacement is negligible. Thus, the preload applied to bearings C, D and E in the figure below will be approximately the same in both vertical shaft and horizontal shaft configurations.

However, in addition to the forces of each spring, bearings A and B will also be affected by the dead weight of the shaft in vertical operation. Axial loads exerted from the free end towards the fixed end (from right to left in the figure below) will reduce preload of bearings A and B. It is necessary to consider these effects when setting preloads for bearings A and B so that they will not become unloaded.

Fig. 4.6 Distribution of Preload in Constant Pressure Preload

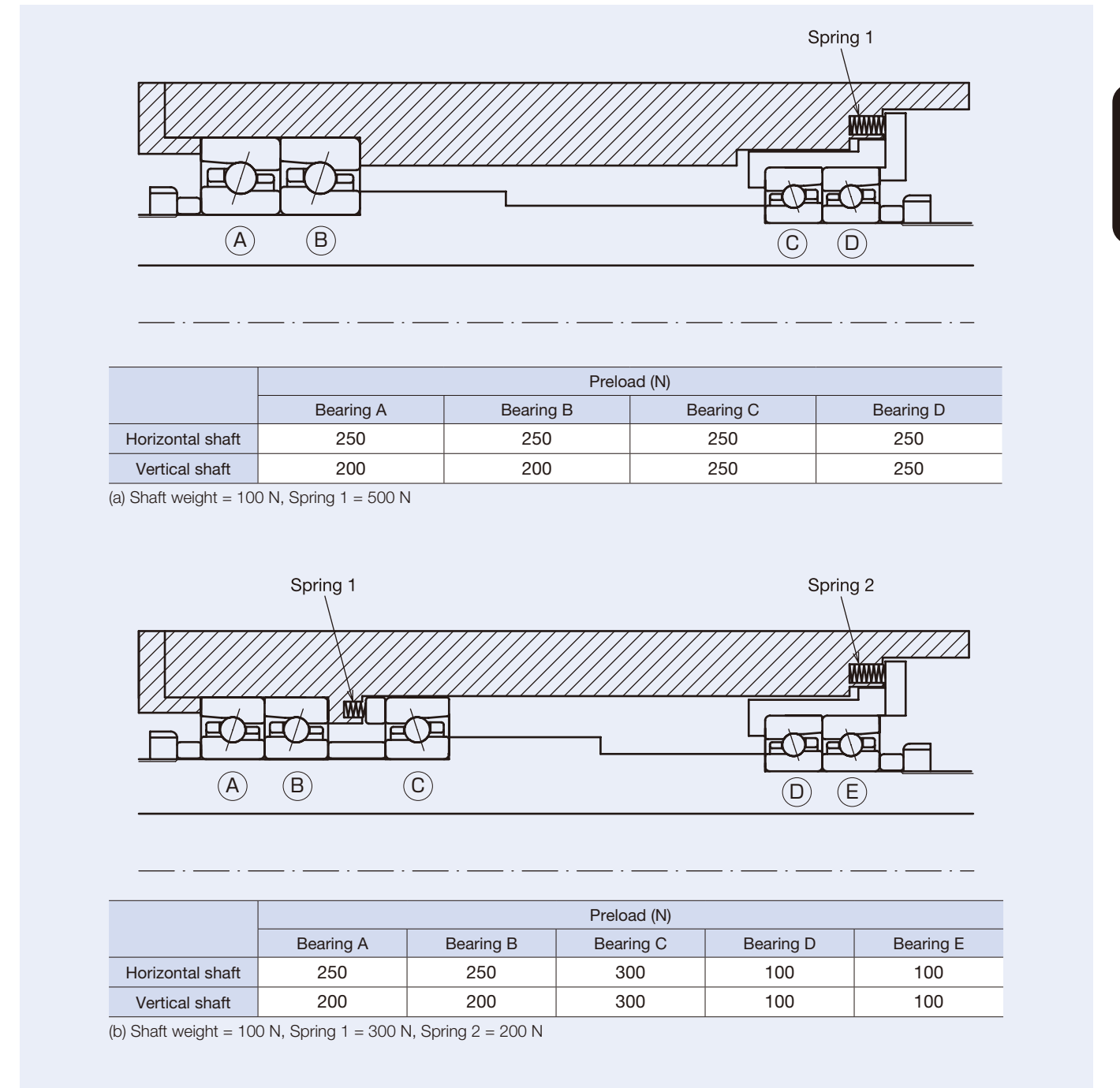

Preload and Axial Rigidity

Generally, when an axial load F_a is applied to a bearing it is possible to calculate the axial displacement δ_a of the bearing using the following formula:

For angular contact ball bearings: $\delta_a = cF_a^{2/3}$

For tapered roller bearings: $\delta_a = cF_a^{0.9}$

Where c is a constant that depends on the bearing's internal design.

As the displacement is increased by axial load to the 0.9 for tapered roller bearings and the 2/3 for ball bearings, the effect of preload application to reduce displacement is stronger with ball bearings.

The above equation refers to elastic displacement between the rolling elements (balls, tapered rollers) and the inner and outer rings. Actual axial displacement will also depend on the material and the thickness of shaft and housing as well as on shaft fit and housing fit. For axial displacement that takes these mounting factors into account, please contact NSK.

Fig. 4.7 Axial Load and Axial Displacement in Single Row Bearings

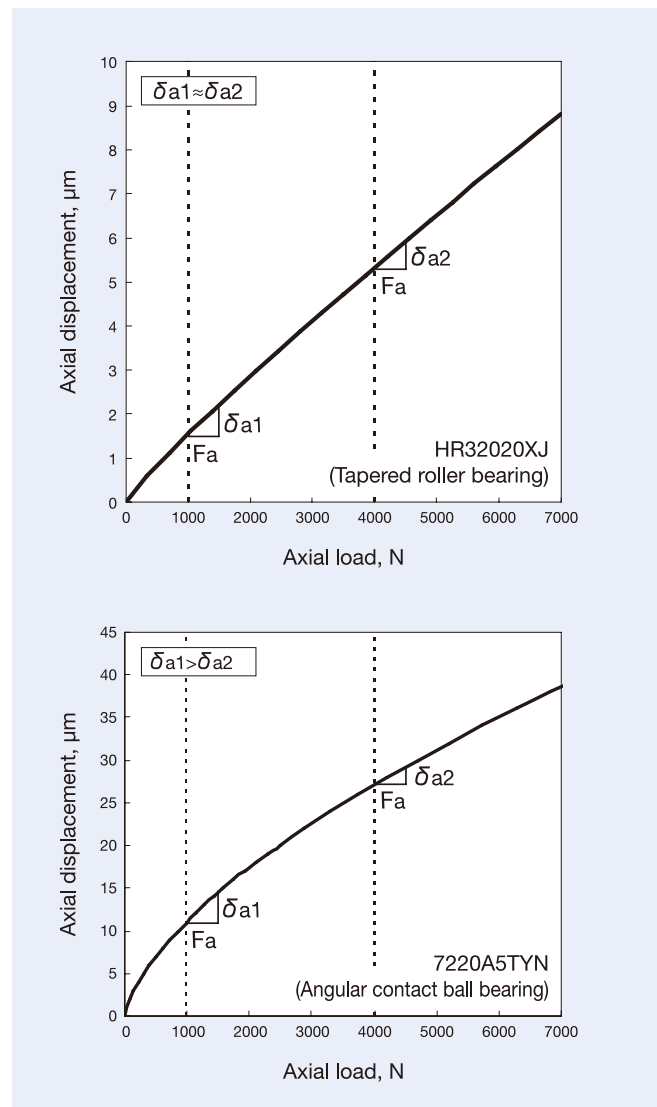
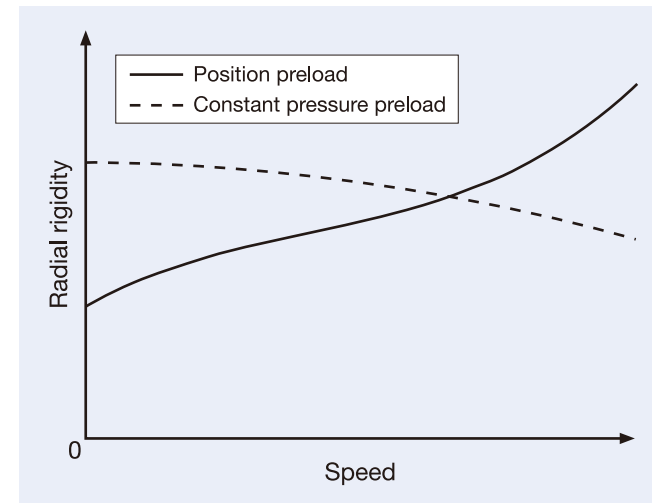

Fig. 4.8 Comparison of Rigidity under each Preloading Method



Comparison of Preloading Methods

Position preload and constant pressure preload can be compared as follows:

- (1) Position preload provides greater bearing rigidity than constant pressure preload at the same amount of preload. In other words, the deflection due to external loads is less for bearings with position preload.
- (2) Under position preload, the preload varies during operation depending on such factors as a difference in axial expansion due to a temperature difference between the shaft and the housing, a difference in radial expansion due to a temperature difference between the inner and outer rings, and the effect of centrifugal force acting on the rolling elements. Under constant pressure preload, the variation of spring load due to shaft expansion and contraction etc. is minimal, so its effect on preload is negligible.

With position preload, bearing rigidity will generally increase with spindle speed because preload increases during operation. In contrast, the preload level with constant pressure preload will remain constant. However, the contact angle will change due to centrifugal force acting on the balls (Fig. 1.7 on page 197) and result in a decrease of rigidity (Fig. 4.8).

Consequently, position preloads are generally preferred where increasing rigidity is desired, while constant pressure preloads are more suitable for high-speed applications, for applications where axial vibration needs to be prevented, for use with thrust bearings on horizontal shafts, etc.

Preloading Amount

A larger preload results in higher rigidity. However, increasing preload reduces fatigue life and increases heat generation. In extreme cases, excessive preload may result in abnormal wear or even seizure.

Therefore, the amount of preload needs to be carefully selected taking into consideration the type of application and the operating conditions, to avoid larger preload than necessary.

High-Speed Spindles and Preload

When bearings are operated at high speed, internal load increases as a result of the expansion of the inner ring due to centrifugal force, the effect centrifugal force has on balls, and the temperature difference between inner and outer ring. Then, surface contact pressure between the balls and the raceways of the inner and outer ring will increase. For bearings having a contact angle, such as angular contact ball bearings, pure rolling motion will be accompanied by sliding as a result of spin moments and gyroscopic moments on the balls. Sliding increases as bearing speed increases. As a result, the intensity of heat generated in the contact areas increases and the viscosity of the lubricating oil decreases. In some cases, a breakdown of the oil film occurs, which results in bearing seizure. This means that even if contact surface pressure were to remain unchanged from low-speed operation to high-speed operation, heat generation would still increase as speed increases due to sliding.

At NSK, we calculate contact surface pressure and slip rate generated during high-speed operation by computer. Based on our own abundant empirical test data as well as market results, we have established limiting factors according to the lubricating method and rotating speed; this is the foundation on which we determine preload. For applications exceeding $800,000 d_m n$, please contact NSK.

For high-speed bearings in constant pressure preload, a medium preload (M) per row is commonly chosen as a guideline value and then adjusted according to the required rigidity and the temperature rise in high-speed operation.

Preload for Thrust Bearings

Thrust bearings generally require an axial load in order to prevent slipping between the rolling elements and the washers.

The minimum axial load required to prevent rolling element slippage can be calculated using the equation below. In cases where shaft dead weight is insufficient, a preload needs to be added, e.g. by a spring.

For minimum axial load in the case of horizontal shafts, please contact NSK.

For thrust ball bearings: $F_{a \min} = Mn^2$

- where $F_{a \min}$: Minimum axial load (kN)
 M : Minimum load factor (listed in bearing tables)
 n : Maximum speed during operation (min^{-1})

For thrust cylindrical roller bearings: $F_{a \min} = 0.0005C_{0a} + Mn^2$

- where $F_{a \min}$: Minimum axial load (kN)
 M : Minimum load factor (listed in bearing tables)
 C_{0a} : Basic static axial load rating (kN)
 n : Maximum speed during operation (min^{-1})

Internal Clearance in Cylindrical Roller Bearings

In order for machine tool spindles to have high running accuracy and rigidity, bearings are used with minimum internal clearance or preload after mounting. When using cylindrical roller bearings, bearings with tapered bores are usually used to allow easier adjustment of internal clearance. In general, cylindrical roller bearings for the front end (fixed end) of the spindle are adjusted upon mounting to have a preload during operation. Bearings for the rear end (free end) are adjusted upon mounting to produce a slight clearance during operation. The amount of internal radial clearance after mounting is determined based on several factors such as speed, load, lubricating method, bearing size, required rigidity, service life, etc.

Fig. 4.9 shows the relationship between internal radial clearance and rolling fatigue life as well as the relationship between internal radial clearance and radial elastic displacement for a cylindrical roller bearing (NN3020, bore diameter 100 mm, outside diameter 150 mm, width 37 mm).

Fig. 4.9 Influence of Internal Radial Clearance on Rolling Fatigue Life and Rigidity in a Double-Row Cylindrical Roller Bearing

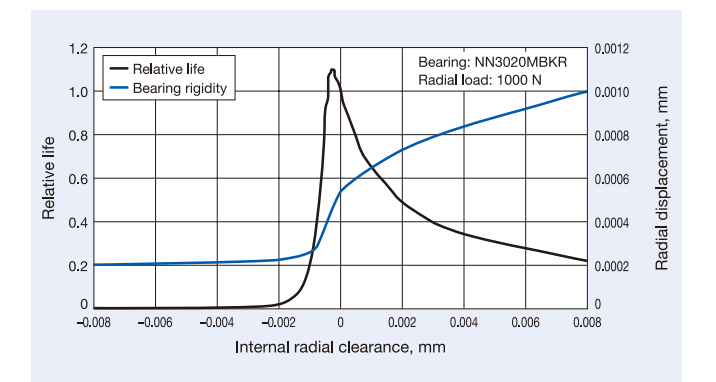

Limiting Speeds

The limiting speeds listed in the bearing tables are guideline values. They are applicable when all of the following criteria are met:

- A single bearing, appropriately preloaded using springs
- A spindle system controlled for unbalance
- Good heat dissipation
- Good lubrication
- Inner ring rotation

These values are not guaranteed for continuous operation over a prolonged period. Especially in the case of grease lubrication, it is recommended to choose suitable speeds taking grease life into consideration.

The limiting speeds with grease lubrication require appropriate amounts of high quality grease to be applied appropriately as well as sufficient run-in. Refer to page 256 for grease application procedures, page 268 for running-in.

Limiting speeds for oil lubrication are based on oil-air (or oil mist) lubrication. It is possible to achieve higher speeds in cases where oil serves to efficiently remove heat, as in jet lubrication.

In order to achieve high-speed operation, it is necessary to keep bearing load (including internal load), heat generation and temperature increase down. In addition to those mentioned, the following factors also exert an influence on limiting speeds:

(1) Preloading Method

Under position preload, internal preload increases when speed is increased. As a general rule, limiting speed with position preload will be lower than with constant pressure preload.

(2) Bearing Positioning and Arrangement

The number of rows in a combination of bearings affects load distribution. The limiting speed will be determined by the bearing operating under the most stress within a combination. In addition, even under the same preload, heat dissipation will be affected by the presence or absence of spacers and by spacer length.

(3) Bearing Load

High speed and heavy load are difficult to combine. Load endurance is affected by speed.

(4) Drive Method

Spindle drive systems can be classified roughly into three groups: (a) coupling drives (b) built-in motor drives (c) belt or gear drives. (a) High eccentricity in coupling drives leads to shaft vibrations that result in lower limiting speeds. (b) With built-in motor drives, internal heat generation of the spindle is high; so it is especially bearings located near the motor that could be affected and damaged by heat. In spindles equipped with jacket cooling, the temperature difference between the

Table 5.1 Speed Factors for Position Preload

Arrangement	Preload after mounting			
	EL	L	M	H
DB	0.85	0.80	0.65	0.55
DBB	0.80	0.75	0.60	0.45
DBD	0.75	0.70	0.55	0.40
DBBD	0.75	0.70	0.55	0.40

inner ring and the outer ring of the bearing will likely increase; in the case of position preload this results in the internal load increasing, which in turn means lower limiting speeds (Fig. 5.2). (c) In gear or belt drives, the driving force itself may have to be considered. Caution is required with high-torque spindles and high-speed spindles in particular.

(5) Mounting Conditions

In the case of position preload, the shaft fit will affect preload. Spacer length and tightening force also affect bearing clearance, thereby changing preload.

Housing fit conditions will greatly influence preload, particularly during operation. Too little clearance between bearing and housing will lead to an interference fit due to the difference in heat expansion between bearing and housing; this increases internal preload (Fig. 5.3).

If cylindrical roller bearings are mounted with excessive negative clearance, the limiting speed will decline due to rising heat generation. (page 46)

Speed Factors for Position Preload

The limiting speed of a combination of angular contact ball bearings is calculated by multiplying the limiting speed of a single bearing in the combination by the appropriate adjustment factor listed in Table 5.1. The preload classification in the table refers to the preload after the bearings have been attached to the spindle (i.e. preload after mounting).

Usually, preload after mounting is affected by shaft fit and spacer deformation and may exceed that resulting from initial axial clearance. For example, an EL preloaded bearing mounted with high interference, may have a preload after mounting that is equivalent to an M preload. It will be necessary to adjust axial clearance using spacers according to the conditions in which the bearings are used.

In order to maintain stable operation over time, it is advisable to reduce the values given in Table 5.1 further by a safety factor of 0.75.

Calculation example:

Target value for 70BNR10HTDB, EL preload after mounting, grease lubrication: (limiting speed) 20000 × (EL) 0.85 × (safety factor) 0.75 = 12750min⁻¹

Factors that Change Preload

Fig. 5.1 Preload Setting Study Flow

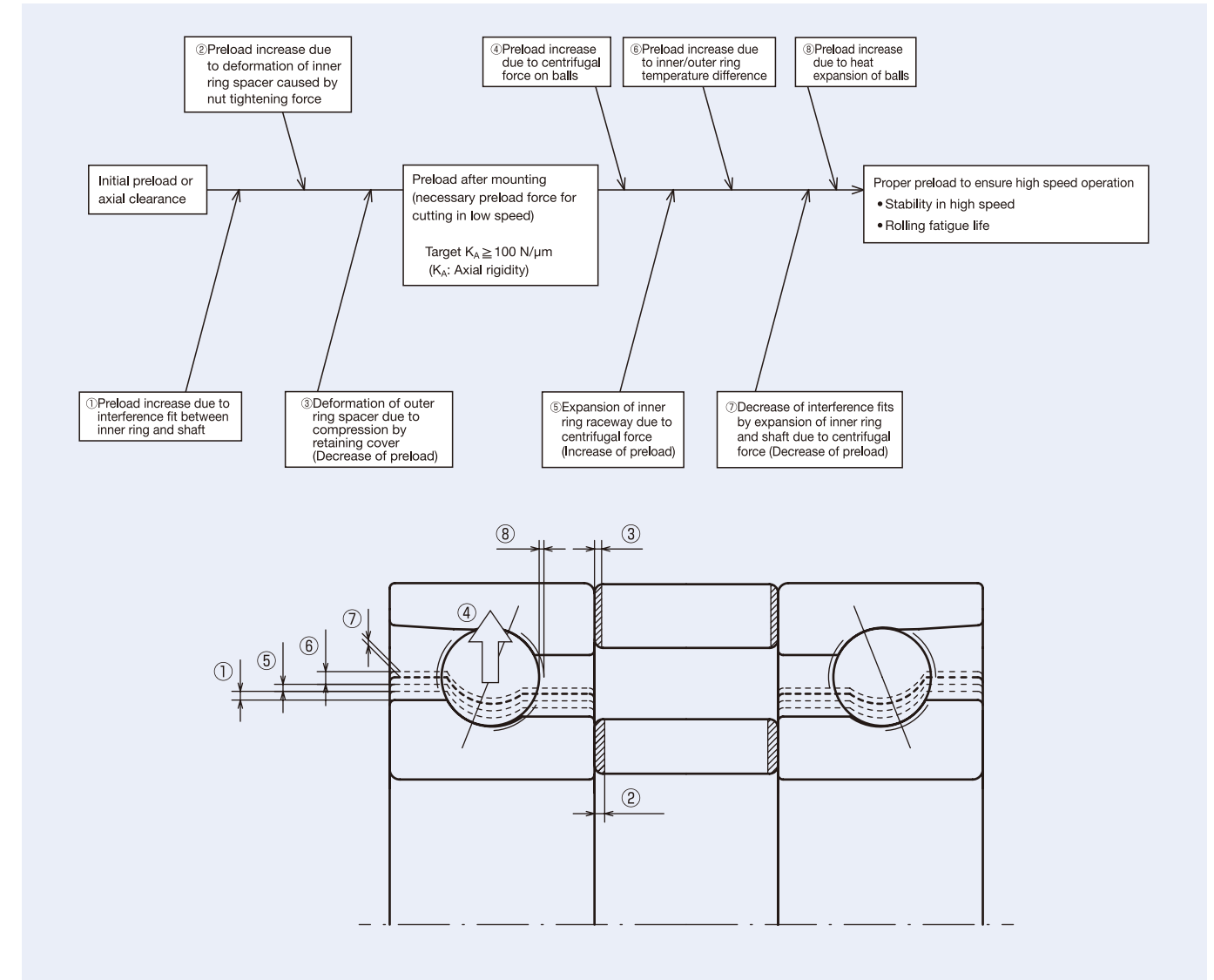

Fig. 5.2 The Influence of the Jacket Cooling on Limiting Speed

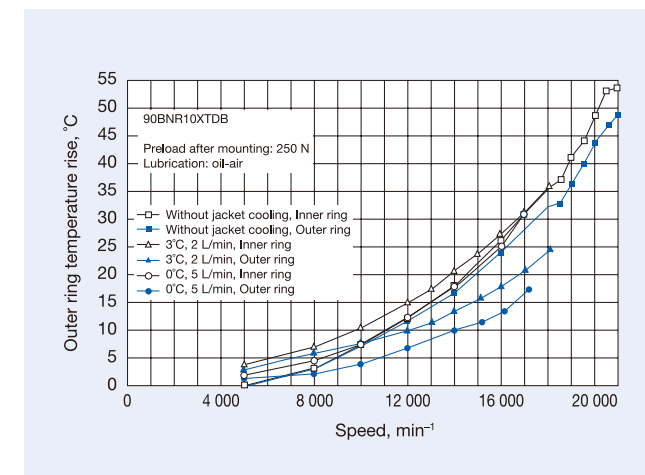
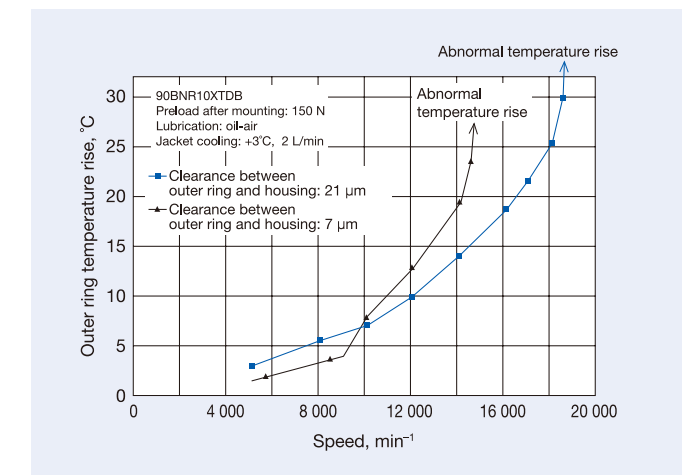

Fig. 5.3 The Influence of the Clearance between the Bearing & the Housing on Limiting Speed



Purposes of Lubrication

The main purpose of lubrication is to reduce friction and wear inside the bearing and thereby to prevent seizure. The effects of lubrication may be briefly explained as follows:

(1) Reduction of Friction and Wear

Direct metallic contact between the bearing rings, rolling elements, and cage, which are the basic parts of a bearing, is prevented by an oil film which reduces the friction and wear in the contact areas.

(2) Extension of Fatigue Life

Appropriate lubrication of the rolling contact surfaces extends the rolling fatigue life of bearings. This requires suitable viscosity of the lubricant. If the viscosity of the oil is too low so the film thickness is insufficient, rolling fatigue life will be shortened.

(3) Dissipation of Heat

Circulating lubrication may be employed to remove frictional heat or heat transferred to the bearing from the outside. This prevents the bearing from overheating and the lubricant itself from deteriorating.

(4) Others

Adequate lubrication also helps to prevent foreign material from entering the bearings and guards against corrosion or rusting.

Lubricating Methods

For machine tool spindles in which high accuracy is important, it is necessary to prevent excessive temperature rise of the spindle to reduce thermal deformation.

Bearing heat generation is divided into a load term determined by the bearing type and load, and a speed term determined by the lubricating method and speed.

Generally, the speed term is greater, but if a lubricating method resulting in a small speed term is selected, the influence of the load term cannot be disregarded. Therefore, it is important to select a low heat generating bearing (load term) and lubricating method (speed term).

Regarding heat generation, both the lubricating method and the quantity of lubricant have important effects. Lubrication using a small amount of grease is common since this method is economical, maintenance free, and there is little heat generation. The oil-air lubricating method requiring a minimum quantity of oil was developed to maintain a constant low temperature in conjunction with high speeds. Refer to Table 6.1. for a comparison of lubricating methods.

The relation between oil quantity and heat generation (frictional loss) and temperature rise is already known as shown in Fig. 6.1. In zone A, oil is employed in the minimal quantity necessary. This minimizes agitation resistance and the amount of associated heat generation. However, caution is required since oil quantities lower than zone A pose the risk of insufficient lubrication causing heat increase and bearing failure.

In zone B, the oil quantity is higher which means more heat is generated due to oil agitation. However, once a certain quantity is exceeded, temperature decreases as the oil transports some of the heat away from the bearing.

In this case, the amount of oil needed depends on the oil drain features of the machine, allowable temperature, heat dissipation, and the heat generation characteristics of the oil due to agitation resistance. The adequate oil amount is thus often determined empirically.

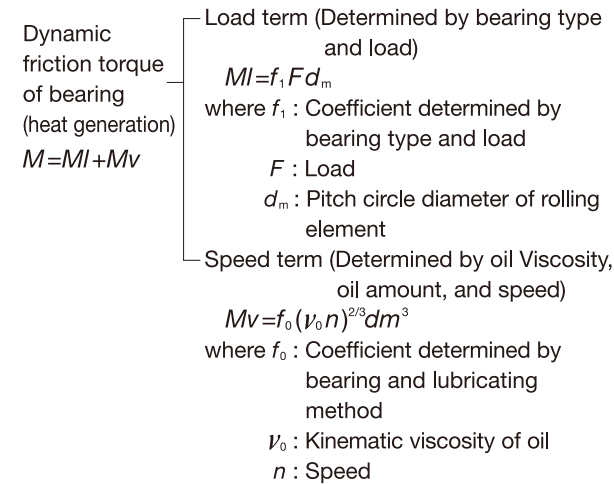

Fig. 6.1 Oil Quantity and Temperature Rise

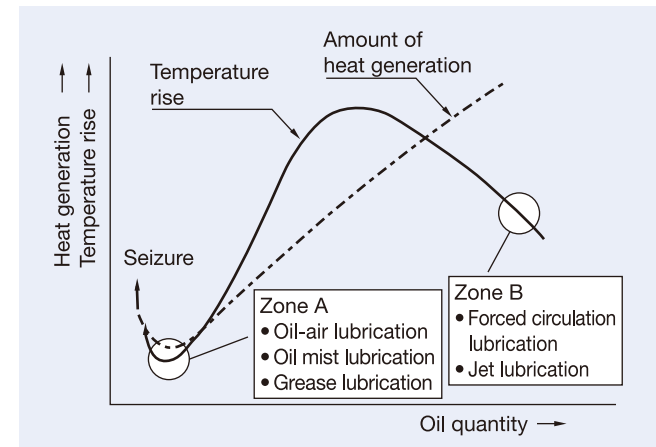

Table 6.1 Comparison of Lubricating Methods

Lubricating Method	Advantages	Disadvantages
Grease Lubrication	<input type="checkbox"/> Cost is low. <input type="checkbox"/> Limitation of temperature rise is possible. <input type="checkbox"/> Maintenance free.	<input type="checkbox"/> If packed grease deteriorates, seizure may occur. <input type="checkbox"/> May allow penetration of dust or cutting fluid.
Oil Mist Lubrication	<input type="checkbox"/> Since new oil is always fed, no fear of oil deterioration. <input type="checkbox"/> Dust and cutting fluid cannot easily enter.	<input type="checkbox"/> Pollution of environment. <input type="checkbox"/> Oil supply quantity varies depending on the oil viscosity and temperature, so control of a small flow rate is difficult. <input type="checkbox"/> It is difficult to confirm that oil is actually fed.
Oil-Air Lubrication	<input type="checkbox"/> Since oil quantity control is possible, the optimum quantity of oil is fed and heat generation is low. <input type="checkbox"/> Besides little heat-generation, there is a cooling effect of the air, so the temperature rise low. <input type="checkbox"/> Since new oil is always fed, no fear of oil deterioration. <input type="checkbox"/> Dust, cutting fluid cannot easily enter. <input type="checkbox"/> Environmental pollution mist is slight.	<input type="checkbox"/> Cost is rather high. <input type="checkbox"/> Confirmation of whether oil is actually fed to bearing is difficult.
Jet Lubrication	<input type="checkbox"/> Since the oil flow rate is high, dust and cutting fluid cannot enter and seizure hardly ever occurs. <input type="checkbox"/> Because of cooling by oil, the bearing temperature can be controlled to some degree.	<input type="checkbox"/> Frictional loss is high. <input type="checkbox"/> Since oil leaks, it is difficult to use for vertical spindles. <input type="checkbox"/> Cost is high.

Grease Lubrication

(1) Recommended Greases

For grease lubrication of bearings in high-speed machine tool spindles that require low temperature rise and long life, a consistency No.2 or No.3 grease with a synthetic base oil (diester, diester + mineral oil, etc.) is recommended.

Table 6.2 lists the brand names and properties of greases widely used in machine tool spindles and ball screw support bearings.

Grease life depends to a large degree upon operating temperature. Therefore, it is necessary to keep the temperature of the bearing (including atmospheric temperature) cool in order to extend grease life.

(2) Grease Quantities for High-Speed Spindle Bearings

To operate bearings at high speed with grease lubrication, the recommended quantity to be packed is 10% to 30% of

internal space. If too much grease is packed, abnormal heat generation occurs especially during running-in; this may cause the grease to deteriorate. To avoid such a risk, it is necessary to run in spindles for a sufficient time. Based on accumulated experience, NSK determines packing quantities that allow easy running in and will provide sufficient lubrication. These recommended grease quantities are listed in the table on page 257.

(3) Grease Quantities for Ball Screw Support Bearings

As bearings for ball screw support are usually operated at slow speed, under high load, and in intermittent operation, we recommend a grease quantity of 30% to 55% of internal space for increased reliability. Recommended grease quantities for each bearing are listed in the bearing tables for ball screw support bearings.

Table 6.2 Grease Brand Names and Properties

Brand Name	Thickener	Base Oil	Base Oil Viscosity, mm ² /s (40°C)	Dropping Point (°C)	Working (1) Temperature Range (°C)	Main Applications
ROBUSTGRD	Lithium complex soap	Poly- α -olefin+Mineral oil	32.3	223	-20 to +130	Bearings for high-speed spindles
MTE Grease	Barium complex soap	Mineral oil + Ester oil (2)	23	>260	-20 to +130	Bearings for high-speed spindles
MTS Grease	Urea (3)	Poly- α -olefin+Ester oil (2)	22	>220	-40 to +130	Bearings for high-speed spindles
TURMOGREASE HIGH SPEED L252	Lithium soap	Poly- α -olefin+Ester oil (2)	25	>250	-50 to +120	Bearings for high-speed spindles
STABURAGS NBU 8 EP	Barium complex soap	Mineral oil	105	>220	-10 to +130	Bearings for high load spindles
EA7 Grease	Urea (3)	Poly- α -olefin oil	46	>260	-40 to +160	Bearings for motors
ENS Grease	Urea (3)	Polyol ester oil (2)	30.5	>260	-40 to +160	Bearings for motors
Alvania S2	Lithium soap	Mineral oil	130	185	-10 to +110	Ball screw support bearings
WPH	Urea (3)	Poly- α -olefin oil	95.8	259	-40 to +150	Ball screw support bearings
FS2	Lithium soap	Mineral oil	139	205	-10 to +110	Ball screw support bearings, heavy load applications
Multemp PS No. 2	Lithium soap	Poly- α -olefin + Diester oil (2)	15.9	190	-50 to +110	Ball screw support bearings, light load applications
Klüberplex BEM 41-132	Lithium soap	Mineral oil + Poly- α -olefin oil	120	>250	-40 to +150	Ball screw support bearings (standard grease for BSBD Series)

(1) For special application environments such as operating temperatures close to the low end or high end of the range or vacuum etc., please contact NSK.

(2) Caution: Grease containing urea thickener degrades fluorine-based materials.

(3) Caution: Ester oil-based grease causes acrylic materials to swell.

Oil Lubrication

When lubricating bearings with oil, highly purified mineral and synthetic oils that perform well under high loads and offer good anti-oxidative and anti-corrosive properties are used.

The most important factor to consider when choosing lubricating oil is the viscosity it will exhibit at operating temperature. If viscosity is too low, the oil film will be insufficient which may cause abnormal wear and seizure. If viscosity is too high, the agitation resistance of the oil will generate more heat and lead to power loss. Oil film formation is also influenced by operating speed and load conditions.

Generally, the higher the operating speed the lower the viscosity of the oil used. The higher the bearing load, or the larger the size of the bearing, the higher the viscosity of the oil used. Table 6.3 shows guideline values for oil viscosity at oil temperatures in the vicinity of operated bearings under normal operating conditions.

To aid your selection of lubricating oil, Fig. 6.2 shows the relationship between oil temperature and viscosity.

(1) Oil Mist and Oil-Air Lubrication (Minimal Oil Quantity Lubrication)

Oil mist lubrication sprays oil by turning it into a mist using compressed air.

Oil-air lubrication meanwhile feeds oil continuously by injecting oil into a compressed air stream by means of a mixing valve that intermittently discharges the minimum quantity of oil using a constant-quantity piston. Fig. 6.3 shows the recommended oil quantity for these minimal oil quantity lubrication methods; each quantity is for one bearing. In the case of oil mist lubrication, it is necessary to adjust the oil

Fig. 6.2 Relationship of Viscosity and Temperature for Lubricating Oil

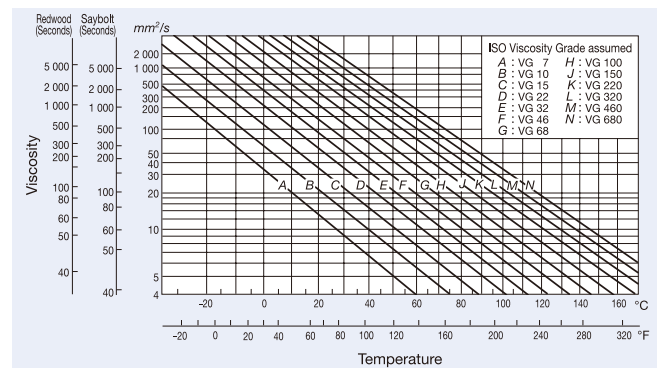
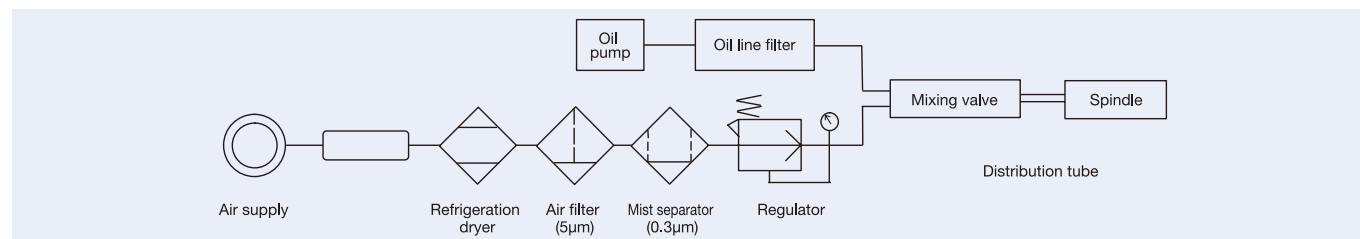

Fig. 6.4 Oil-Air Lubrication System (Example)



quantity to accommodate the effects of the branches in distribution tubing and leakage from the gaps around the spacers. Additionally, note that high-speed operations require oil supply adjustments as high speeds typically increase the quantity of oil needed for proper lubrication.

For the position of the spray nozzle, please refer to pages 240-241.

Example of an oil-air lubrication system

Air supply

- Clean and dry compressed air
- Dew point 3°C or lower
- Air pressure: 0.2 to 0.5 MPa (0.4 to 0.45 recommended)

Lubricating oil

- Clean high-speed spindle oil, or turbine oil (With online filter, if needed)
- Viscosity: 22 to 68 cSt

Distributing tube for oil-air

- Length of distribution tubing: 1.5 to 5 m (3.5 to 5 m recommended)
- Inner diameter of distribution tubing: 2 to 2.5 mm (transparent urethane tube with 4mm outside diameter etc.)

Please refer to the instruction manual of your lubrication device manufacturer etc. for details.

Table 6.3 Required Viscosity of Lubricating Oil by Bearing Type

Bearing Type	Kinematic Viscosity During Operation
Ball bearings, Cylindrical roller bearings	13 cSt or higher
Tapered roller bearings	20 cSt or higher

Fig. 6.3 Recommended Oil Quantity by Bearing Bore Size (Minimal Oil Quantity Lubrication)

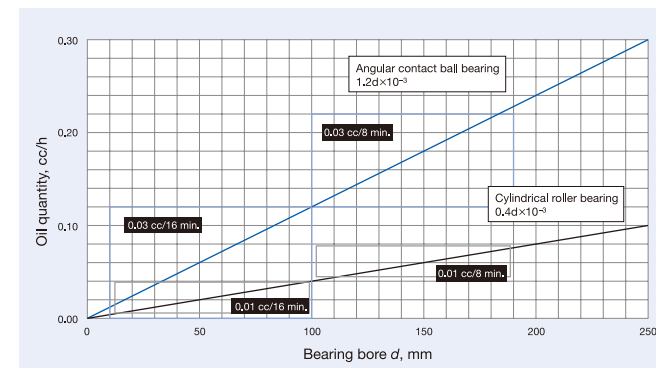

(2) Jet Lubrication

Jet lubrication is mainly used for high-speed bearings with a $d_m n$ value of more than 1.0×10^6 . Jets of lubricating oil pass through the bearings via one or several nozzles at a constant pressure. In high-speed applications, the air surrounding the bearing rotates together with the bearing and forms a wall of air. The speed of the jet from each nozzle must exceed the circumferential speed of the inner ring outside surface by at least 20%. To cool bearings and shaft down uniformly, it proves advantageous to increase the number of nozzles. Enlarging the oil discharge outlet or employing forced discharge should also be considered so as to improve heat removal.

Though it increases equipment size, this method is used for machine tool spindle bearings in some applications as a means of achieving stable operation at ultra-high speeds (see Fig. 6.5). For the position of the spray nozzle, please refer to pages 240-241.

Fig. 6.5 Jet Lubrication Spindle (Example)

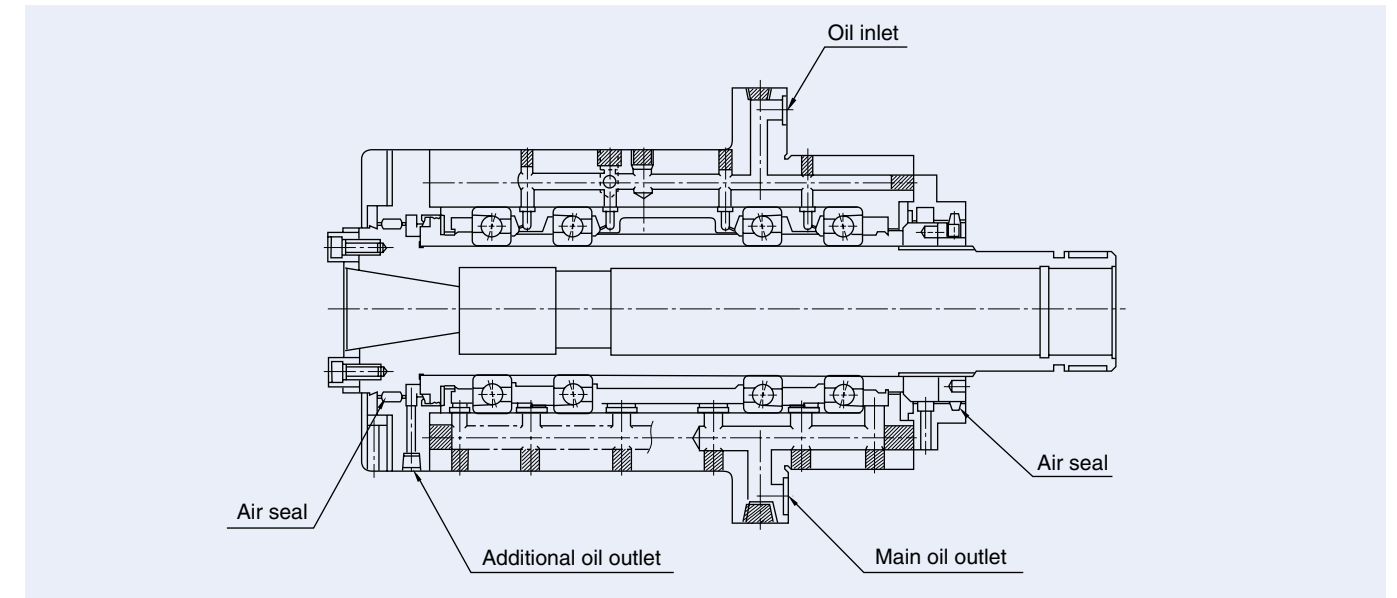

Oil Amount in Forced-Circulation Lubrication

The equation below can be used to estimate the amount of oil needed for a bearing with forced-circulation lubrication.

$$Q = \frac{0.19 \times 10^{-5}}{T_2 - T_1} d \mu n F \text{ (N)} \dots\dots\dots (1)$$

- where Q : Oil supply rate (liters/min)
- T_1 : Oil temperature at oil inlet (°C)
- T_2 : Oil temperature at oil outlet (°C)
- d : Bearing bore (mm)
- μ : Dynamic friction coefficient (guideline value, determined by bearing type, see Table 6.4)
- n : Bearing speed (min⁻¹)
- F : Bearing load (N)

Table 6.4 Dynamic Friction Coefficient (Guideline Values)

Bearing Type	Coefficient μ
Angular contact ball bearings	0.0015
Thrust ball bearings	0.0011
Cylindrical roller bearings	0.0010
Tapered roller bearings	0.0022
Thrust cylindrical roller bearings	0.0040

The value calculated from equation (1) is a guideline only and may be modified after considering such factors as the restrictions on oil inlet and oil outlet bore sizes.

Note that the oil drain pipe and oil outlet bore must be designed large enough to prevent stagnation of the circulating oil in the housing.

The oil amount obtained from equation (1) is too large for large bearings (bore sizes of more than 200 mm) if they are exposed to heavy loads. In these cases a value of about 2/3 to 1/2 of the calculated value should be taken as a guideline and the final value determined after having been confirmed on the actual machine.

7. Bearing Tolerances

The tolerances for boundary dimensions and running accuracy of NSK radial bearings are specified by the Accuracies of Rolling Bearings in ISO 492/199/582/1132-1, and Rolling Bearing Tolerances in JIS B 1514. In addition to the above tolerances, NSK manufactures angular contact ball bearings with precision classes ABEC 5, 7, and 9 as specified by American Bearing Manufacturers Association (ABMA) Standard 20.

Rough definitions of the items listed for running accuracy and their measuring methods are described in Table 7.1 and Fig 7.1. Further details are available in ISO 5593, Rolling Bearings Vocabulary in JIS B 0104, and Measuring Methods for Rolling Bearings in JIS B 1515.

Table 7.1

Running Accuracy		Inner Ring	Outer Ring	Dial Gauge
Radial runout of inner ring of assembled bearing	K_{ia}	Rotating	Stationary	A
Radial runout of outer ring of assembled bearing	K_{ea}	Stationary	Rotating	A
Axial runout of inner ring of assembled bearing	S_{ia}	Rotating	Stationary	B ₁
Axial runout of outer ring of assembled bearing	S_{ea}	Stationary	Rotating	B ₂
Perpendicularity of inner ring face surface with respect to the bore	S_d	Rotating	Stationary	C
Perpendicularity of outer ring outside surface with respect to the face	S_D	—	Rotating	D
Variation in thickness between shaft washer (housing washer) raceway and back face	S_i, S_e	Only the shaft washer or the housing washer is to be rotated		E

Fig. 7.1 Measuring Methods for Running Accuracy

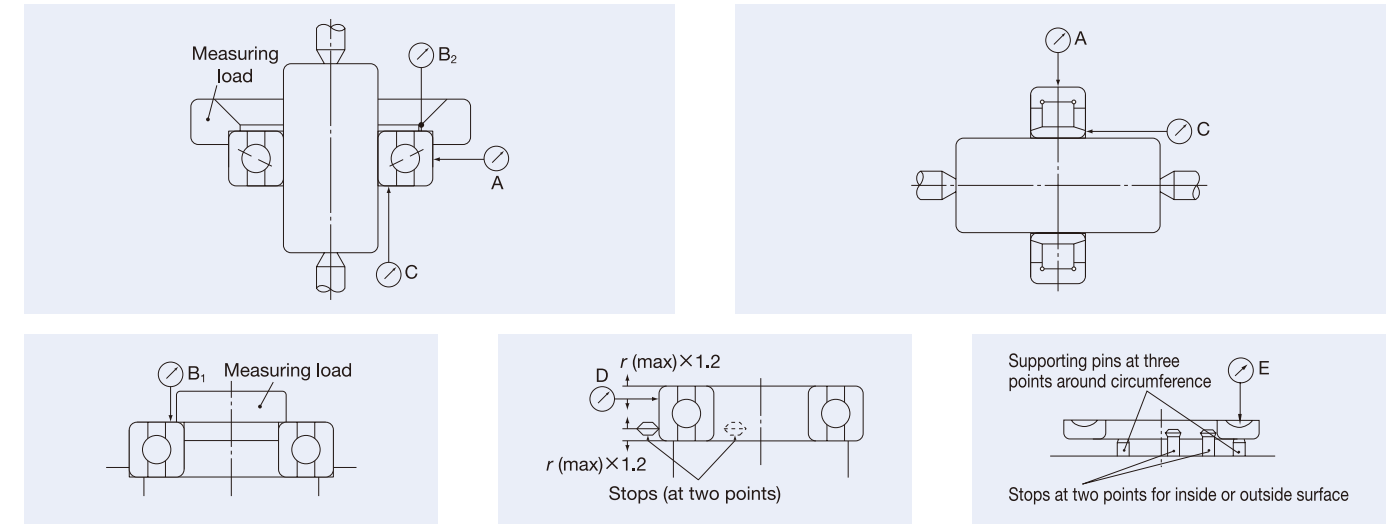

Tolerances for Radial Bearings (excluding Tapered Roller Bearings)

Inner Ring

Table 7.2 Inner Ring (Class 5)

Unit: μm

Nominal Bore Diameter d (mm)	Single Plane Mean Bore Dia. Deviation Δ_{dmp} (°)			Bore Dia. Variation in a Single Radial Plane V_{dp} (°)		Mean Bore Dia. Variation V_{dmp} (°)	Radial Runout of Inner Ring K_{ia}	Inner Ring Runout with Bore S_d	Inner Ring Face Runout with Raceway S_{ia} (°)	Deviation of Single Inner Ring Width Δ_{Bs}			Inner Ring Width Variation V_{Bs}	
	Over	Incl.	High	Low	Diameter Series					Single Bearing Combined Bearing	Single Bearing	Combined Bearings (°)		
					g									0, 2, 3
2.5	10	0	-5	5	4	3	4	7	7	0	-40	-250	5	
10	18	0	-5	5	4	3	4	7	7	0	-80	-250	5	
18	30	0	-6	6	5	3	4	8	8	0	-120	-250	5	
30	50	0	-8	8	6	4	5	8	8	0	-120	-250	5	
50	80	0	-9	9	7	5	5	8	8	0	-150	-250	6	
80	120	0	-10	10	8	5	6	9	9	0	-200	-380	7	
120	180	0	-13	13	10	7	8	10	10	0	-250	-380	8	
180	250	0	-15	15	12	8	10	11	13	0	-300	-500	10	
250	315	0	-18	18	14	9	13	13	15	0	-350	-500	13	
315	400	0	-23	23	18	12	15	15	20	0	-400	-630	15	

Table 7.3 Inner Ring (Class 4)

Unit: μm

Nominal Bore Diameter d (mm)	Single Plane Mean Bore Dia. Deviation Δ_{dmp} (°)			Deviation of a Single Bore Dia. Δ_{ds} (°)		Bore Dia. Variation in a Single Radial Plane V_{dp} (°)		Mean Bore Dia. Variation V_{dmp} (°)	Radial Runout of Inner Ring K_{ia}	Inner Ring Runout with Bore S_d	Inner Ring Face Runout with Raceway S_{ia} (°)	Deviation of Single Inner Ring Width Δ_{Bs}			Inner Ring Width Variation V_{Bs}	
	Over	Incl.	High	Low	High	Low	Diameter Series					Single Bearing Combined Bearing	Single Bearing	Combined Bearings (°)		
							g									0, 2, 3
2.5	10	0	-4	0	-4	4	3	2	2.5	3	3	0	-40	-250	2.5	
10	18	0	-4	0	-4	4	3	2	2.5	3	3	0	-80	-250	2.5	
18	30	0	-5	0	-5	5	4	2.5	3	4	4	0	-120	-250	2.5	
30	50	0	-6	0	-6	6	5	3	4	4	4	0	-120	-250	3	
50	80	0	-7	0	-7	7	5	3.5	4	5	5	0	-150	-250	4	
80	120	0	-8	0	-8	8	6	4	5	5	5	0	-200	-380	4	
120	180	0	-10	0	-10	10	8	5	6	6	7	0	-250	-380	5	
180	250	0	-12	0	-12	12	9	6	8	7	8	0	-300	-500	6	

(°) Applicable to individual rings manufactured for combined bearings.

(°) Applicable to bearings with cylindrical bores.

(°) Class 3 is NSK's original accuracy. Tolerance of bearing bore diameter and outer ring outside diameter are Class 4. Other tolerances are Class 2.

(°) Applicable to ball bearings.

- Remarks:
- The bore diameter tolerance limit (High) for bearings with cylindrical bores, as specified in this table, is not necessarily applicable within a distance of 1.2 times the chamfer dimension r (Max.) from the ring face.
 - ABMA Standards ABEC5, ABEC7, and ABEC9 are equivalent to ISO (JIS) Classes 5, 4, and 2 respectively. ABMA Standards are applicable to angular contact ball bearings.

Table 7.4 Inner Ring (Class 3) (°)

Unit: μm

Nominal Bore Diameter d (mm)	Single Plane Mean Bore Dia. Deviation Δ_{dmp} (°)			Deviation of a Single Bore Dia. Δ_{ds} (°)		Bore Dia. Variation in a Single Radial Plane V_{dp} (°)	Mean Bore Dia. Variation V_{dmp} (°)	Radial Runout of Inner Ring K_{ia}	Inner Ring Runout with Bore S_d	Inner Ring Face Runout with Raceway S_{ia} (°)	Deviation of Single Inner Ring Width Δ_{Bs}			Inner Ring Width Variation V_{Bs}	
	Over	Incl.	High	Low	High						Low	Single Bearing Combined Bearing	Single Bearing		Combined (°) Bearing
2.5	10	0	-4	0	-4	2.5	1.5	1.5	1.5	1.5	0	-40	-250	1.5	
10	18	0	-4	0	-4	2.5	1.5	1.5	1.5	1.5	0	-80	-250	1.5	
18	30	0	-5	0	-5	2.5	1.5	2.5	1.5	2.5	0	-120	-250	1.5	
30	50	0	-6	0	-6	2.5	1.5	2.5	1.5	2.5	0	-120	-250	1.5	
50	80	0	-7	0	-7	4	2	2.5	1.5	2.5	0	-150	-250	1.5	
80	120	0	-8	0	-8	5	2.5	2.5	2.5	2.5	0	-200	-380	2.5	
120	150	0	-10	0	-10	7	3.5	2.5	2.5	2.5	0	-250	-380	2.5	
150	180	0	-10	0	-10	7	3.5	5	4	5	0	-250	-380	4	
180	250	0	-12	0	-12	8	4	5	5	5	0	-300	-500	5	

Table 7.5 Inner Ring (Class 2)

Unit: μm

Nominal Bore Diameter d (mm)	Single Plane Mean Bore Dia. Deviation Δ_{dmp} (°)			Deviation of a Single Bore Dia. Δ_{ds} (°)		Bore Dia. Variation in a Single Radial Plane V_{dp} (°)	Mean Bore Dia. Variation V_{dmp} (°)	Radial Runout of Inner Ring K_{ia}	Inner Ring Runout with Bore S_d	Inner Ring Face Runout with Raceway S_{ia} (°)	Deviation of Single Inner Ring Width Δ_{Bs}			Inner Ring Width Variation V_{Bs}	
	Over	Incl.	High	Low	High						Low	Single Bearing Combined Bearing	Single Bearing		Combined (°) Bearing
2.5	10	0	-2.5	0	-2.5	2.5	1.5	1.5	1.5	1.5	0	-40	-250	1.5	
10	18	0	-2.5	0	-2.5	2.5	1.5	1.5	1.5	1.5	0	-80	-250	1.5	
18	30	0	-2.5	0	-2.5	2.5	1.5	2.5	1.5	2.5	0	-120	-250	1.5	
30	50	0	-2.5	0	-2.5	2.5	1.5	2.5	1.5	2.5	0	-120	-250	1.5	
50	80	0	-4	0	-4	4	2	2.5	1.5	2.5	0	-150	-250	1.5	
80	120	0	-5	0	-5	5	2.5	2.5	2.5	2.5	0	-200	-380	2.5	
120	150	0	-7	0	-7	7	3.5	2.5	2.5	2.5	0	-250	-380	2.5	
150	180	0	-7	0	-7	7	3.5	5	4	5	0	-250	-380	4	
180	250	0	-8	0	-8	8	4	5	5	5	0	-300	-500	5	

Inner ring (Class 4Y)

Table 7.6 Tolerances for Bore Diameter of Inner Ring Unit: μm

Bore Diameter (mm)	Class 4		Class 4Y (Median Specification)	
	Over	Incl.	High	Low
30	50	0	-6	-1
50	80	0	-7	-2
80	120	0	-8	-3
120	150	0	-10	-3

* Class 4Y is an NSK proprietary standard in which the tolerances for the bearing bore diameter and outside diameter are in a special class (controlled to a median specification), while other tolerances are per Class 4. Since this minimizes variation in bearing bore diameter and outer ring outside diameter, P4Y is the most suitable tolerance class for universal arrangement bearings.

7. Bearing Tolerances

Tolerances for Radial Bearings (excluding Tapered Roller Bearings)

Outer Ring

Table 7.7 Outer Ring (Class 5)

Unit: μm

Nominal Outside Diameter D (mm)		Single Plane Mean Outside Dia. Deviation Δ_{Dmp}		Outside Dia. Variation in a Single Radial Plane V_{Dp}		Mean Outside Dia. Variation V_{Dmp}	Radial Runout of Outer Ring K_{ea}	Variation of Outside Surface Generatrix Inclination with Face S_D	Outer Ring Face Runout with Raceway S_{ea} (°)	Deviation of Single Outer Ring Width Δ_{Cs}	Outer Ring Width Variation V_{Cs}
				Diameter Series							
Over	Incl.	High	Low	9	0, 2	Max.	Max.	Max.	Max.	Max.	Max.
6	18	0	-5	5	4	3	5	8	8	Equal to the value of inner ring (Δ_{Bs}) of the same designation.	5
18	30	0	-6	6	5	3	6	8	8		5
30	50	0	-7	7	5	4	7	8	8		5
50	80	0	-9	9	7	5	8	8	10		6
80	120	0	-10	10	8	5	10	9	11		8
120	150	0	-11	11	8	6	11	10	13		8
150	180	0	-13	13	10	7	13	10	14		8
180	250	0	-15	15	11	8	15	11	15		10
250	315	0	-18	18	14	9	18	13	18		11
315	400	0	-20	20	15	10	20	13	20		13
400	500	0	-23	23	17	12	23	15	23		15
500	630	0	-28	28	21	14	25	18	25		18
630	800	0	-35	35	26	18	30	20	30		20

Table 7.8 Outer Ring (Class 4)

Unit: μm

Nominal Outside Diameter D (mm)		Single Plane Mean Outside Dia. Deviation Δ_{Dmp}		Deviation of Single Outside Dia. Δ_{Ds}		Outside Dia. Variation in a Single Radial Plane V_{Dp}		Mean Outside Dia. Variation V_{Dmp}	Radial Runout of Outer Ring K_{ea}	Variation of Outside Surface Generatrix Inclination with Face S_D	Outer Ring Face Runout with Raceway S_{ea} (°)	Deviation of Single Outer Ring Width Δ_{Cs}	Outer Ring Width Variation V_{Cs}
						Diameter Series							
Over	Incl.	High	Low	High	Low	9	0, 2	Max.	Max.	Max.	Max.	Max.	Max.
6	18	0	-4	0	-4	4	3	2	3	4	5	Equal to the value of inner ring (Δ_{Bs}) of the same designation.	2.5
18	30	0	-5	0	-5	5	4	2.5	4	4	5		2.5
30	50	0	-6	0	-6	6	5	3	5	4	5		2.5
50	80	0	-7	0	-7	7	5	3.5	5	4	5		3
80	120	0	-8	0	-8	8	6	4	6	5	6		4
120	150	0	-9	0	-9	9	7	5	7	5	7		5
150	180	0	-10	0	-10	10	8	5	8	5	8		5
180	250	0	-11	0	-11	11	8	6	10	7	10		7
250	315	0	-13	0	-13	13	10	7	11	8	10		7
315	400	0	-15	0	-15	15	11	8	13	10	13		8

(¹) Applicable to ball bearings.

(²) NSK specification. Tolerance of bearing bore diameter and outer ring outside diameter are Class 4. Other tolerances are Class 2.

- Remarks:
- The outside diameter tolerance limit (Low) for bearings with cylindrical bores, as specified in this table, is not necessarily applicable within a distance of 1.2 times the chamfer dimension r (Max.) from the ring face.
 - ABMA Standards ABEC5, ABEC7, and ABEC9 are equivalent to ISO (JIS) Classes 5, 4, and 2 respectively. ABMA Standards are applicable to angular contact ball bearings.

Table 7.9 Outer Ring (Class 3) (²)

Unit: μm

Nominal Outside Diameter D (mm)		Single Plane Mean Outside Dia. Deviation Δ_{Dmp}		Deviation of Single Outside Dia. Δ_{Ds}		Outside Dia. Variation in a Single Radial Plane V_{Dp}	Mean Outside Dia. Variation V_{Dmp}	Radial Runout of Outer Ring K_{ea}	Variation of Outside Surface Generatrix Inclination with Face S_D	Outer Ring Face Runout with Raceway S_{ea} (°)	Deviation of Single Outer Ring Width Δ_{Cs}	Outer Ring Width Variation V_{Cs}
				High	Low							
Over	Incl.	High	Low	High	Low	Max.	Max.	Max.	Max.	Max.	Max.	Max.
6	18	0	-4	0	-4	2.5	1.5	1.5	1.5	1.5	Equal to the value of inner ring (Δ_{Bs}) of the same designation.	1.5
18	30	0	-5	0	-5	4	2	2.5	1.5	2.5		1.5
30	50	0	-6	0	-6	4	2	2.5	1.5	2.5		1.5
50	80	0	-7	0	-7	4	2	4	1.5	4		1.5
80	120	0	-8	0	-8	5	2.5	5	2.5	5		2.5
120	150	0	-9	0	-9	5	2.5	5	2.5	5		2.5
150	180	0	-10	0	-10	7	3.5	5	2.5	5		2.5
180	250	0	-11	0	-11	8	4	7	4	7		4
250	315	0	-13	0	-13	8	4	7	5	7		5
315	400	0	-15	0	-15	10	5	8	7	8		7

Table 7.10 Outer Ring (Class 2)

Unit: μm

Nominal Outside Diameter D (mm)		Single Plane Mean Outside Dia. Deviation Δ_{Dmp}		Deviation of Single Outside Dia. Δ_{Ds}		Outside Dia. Variation in a Single Radial Plane V_{Dp}	Mean Outside Dia. Variation V_{Dmp}	Radial Runout of Outer Ring K_{ea}	Variation of Outside Surface Generatrix Inclination with Face S_D	Outer Ring Face Runout with Raceway S_{ea} (°)	Deviation of Single Outer Ring Width Δ_{Cs}	Outer Ring Width Variation V_{Cs}
				High	Low							
Over	Incl.	High	Low	High	Low	Max.	Max.	Max.	Max.	Max.	Max.	Max.
6	18	0	-2.5	0	-2.5	2.5	1.5	1.5	1.5	1.5	Equal to the value of inner ring (Δ_{Bs}) of the same designation.	1.5
18	30	0	-4	0	-4	4	2	2.5	1.5	2.5		1.5
30	50	0	-4	0	-4	4	2	2.5	1.5	2.5		1.5
50	80	0	-4	0	-4	4	2	4	1.5	4		1.5
80	120	0	-5	0	-5	5	2.5	5	2.5	5		2.5
120	150	0	-5	0	-5	5	2.5	5	2.5	5		2.5
150	180	0	-7	0	-7	7	3.5	5	2.5	5		2.5
180	250	0	-8	0	-8	8	4	7	4	7		4
250	315	0	-8	0	-8	8	4	7	5	7		5
315	400	0	-10	0	-10	10	5	8	7	8		7

Outer Ring (Class 4Y)

Table 7.11 Tolerances for Outside Diameter of Outer Ring

Unit: μm

Outside Diameter (mm)		Class 4		Class 4Y (Median Specification)	
Over	Incl.	High	Low	High	Low
30	50	0	-6	-2	-6
50	80	0	-7	-2	-6
80	120	0	-8	-2	-6
120	150	0	-9	-3	-7
150	180	0	-10	-3	-7
180	200	0	-11	-4	-9
200	215 and less	0	-11	-2	-9

*Class 4Y is an NSK proprietary standard in which the tolerances for the bearing bore diameter and outside diameter are in a special class (controlled to a median specification), while other tolerances are per Class 4. Since this minimizes variation in the bearing bore diameter and outer ring outside diameter, P4Y is the most suitable tolerance class for universal arrangement bearings.

Outer / Inner Ring (Class 3W)

Table 7.12 Tolerances for Outside Diameter of Inner / Outer Rings

Unit: μm

Outside Diameter (mm)		Class 3		Class 3W (Median Specification)	
		Combined Bearings		Combined Bearings	
Over	Incl.	High	Low	High	Low
50	80	0	-250	0	-100
80	120	0	-380	0	-100
120	140	0	-380	0	-100
145	150	0	-380	0	-100
165	170	0	-380	0	-100

*Class 3W is an NSK proprietary standard in which the tolerances for the inner and outer ring width are in a special class, while other tolerances are per Class 3. The width tolerances are the same for the inner and outer rings. This standard can apply to universal arrangement bearings (SU, DU, DUD, and QU). Minimizing differences in width improves assembly and reduces the need for adjustments.

Tolerances for Tapered Bores of Cylindrical Roller Bearings

Tolerances for Tapered Bores

The bore accuracy of tapered bore cylindrical roller bearings is specified by ISO. However, in this standard, the tolerances are rather wide. For super precision class cylindrical roller bearings, NSK has established its own narrower tolerance (see Fig. 7.2).

Fig. 7.2 Taper Angle Tolerances

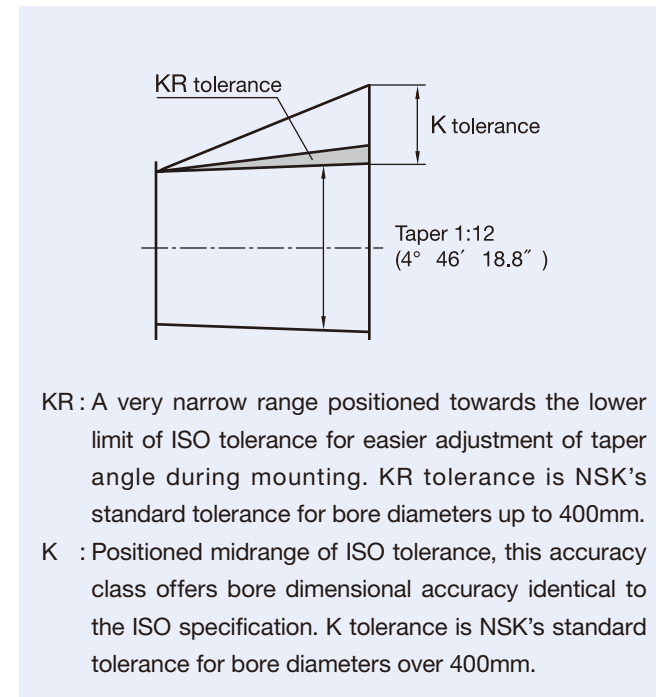

KR : A very narrow range positioned towards the lower limit of ISO tolerance for easier adjustment of taper angle during mounting. KR tolerance is NSK's standard tolerance for bore diameters up to 400mm.

K : Positioned midrange of ISO tolerance, this accuracy class offers bore dimensional accuracy identical to the ISO specification. K tolerance is NSK's standard tolerance for bore diameters over 400mm.

Fig. 7.3 Tapered Bore Tolerances

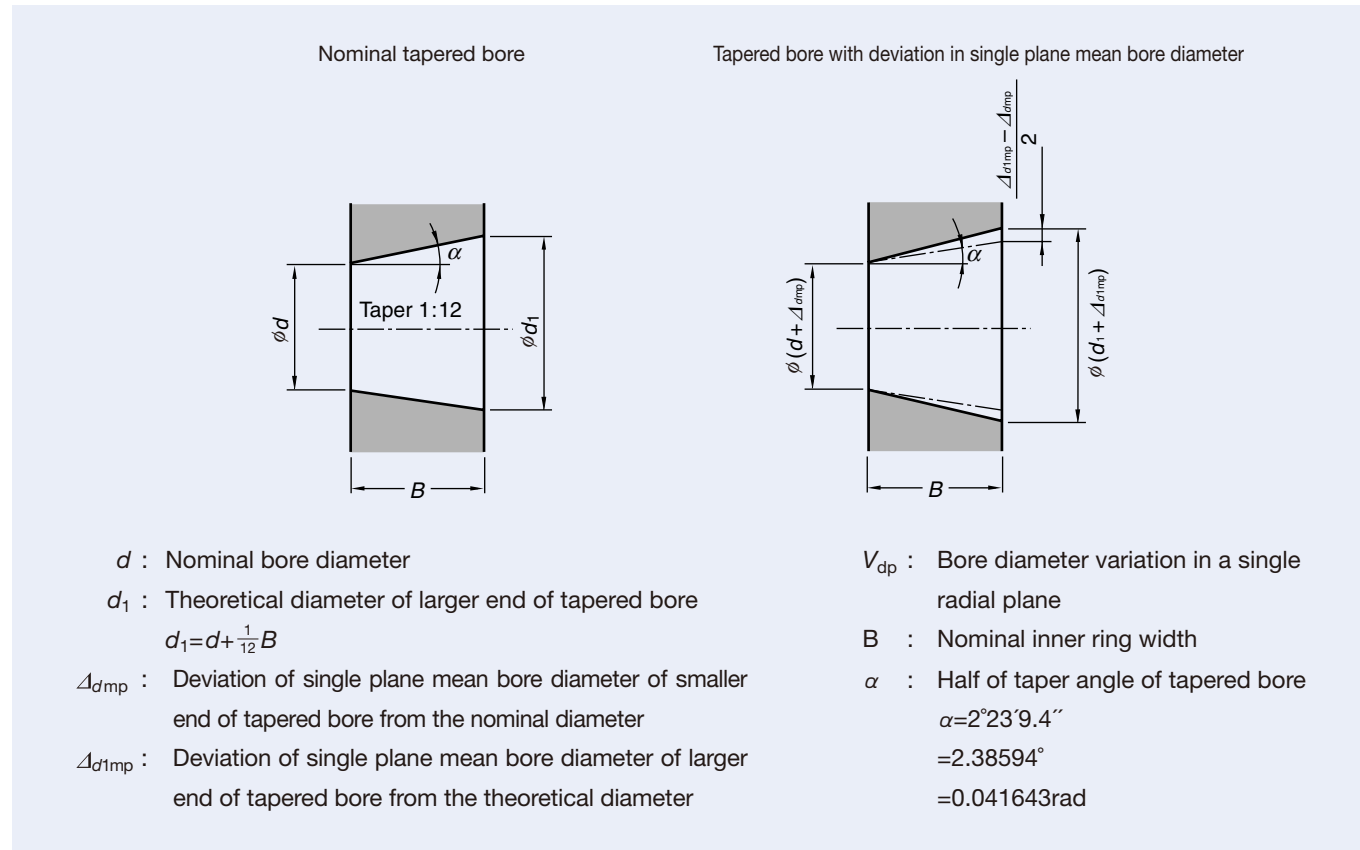

d : Nominal bore diameter

d_1 : Theoretical diameter of larger end of tapered bore

$$d_1 = d + \frac{1}{12}B$$

Δd_{mp} : Deviation of single plane mean bore diameter of smaller end of tapered bore from the nominal diameter

Δd_{1mp} : Deviation of single plane mean bore diameter of larger end of tapered bore from the theoretical diameter

V_{dp} : Bore diameter variation in a single radial plane

B : Nominal inner ring width

α : Half of taper angle of tapered bore
 $\alpha = 2^\circ 23' 9.4''$
 $= 2.38594^\circ$
 $= 0.041643\text{rad}$

Table 7.12 KR Tapered Bores

Unit: μm

d (1) (mm)		Δd_{mp}		(Reference) (2) $\Delta d_{1mp} - \Delta d_{mp}$		V_{dp} (3)
Over	Incl.	High	Low	High	Low	Max.
18	30	+ 13	0	+ 3	0	4
30	50	+ 16	0	+ 3	0	5
50	80	+ 19	0	+ 4	0	6
80	120	+ 22	0	+ 5	0	7
120	180	+ 25	0	+ 7	0	9
180	250	+ 29	0	+ 9	0	12
250	315	+ 32	0	+ 11	0	14
315	400	+ 36	0	+ 12	0	16

(1) For bearings with larger than 400mm bore, please contact NSK.

(2) Bore diameter variation in a single radial plane, which is applicable to all radial planes of tapered bores.

(3) Taper angular tolerance, $4^\circ 46' 18.8'' \pm 25''$

Table 7.13 K Tapered Bores

Unit: μm

d (mm)		Δd_{mp}		$\Delta d_{1mp} - \Delta d_{mp}$		V_{dp} (1)
Over	Incl.	High	Low	High	Low	Max.
18	30	+ 33	0	+ 21	0	13
30	50	+ 39	0	+ 25	0	16
50	80	+ 46	0	+ 30	0	19
80	120	+ 54	0	+ 35	0	22
120	180	+ 63	0	+ 40	0	40
180	250	+ 72	0	+ 46	0	46
250	315	+ 81	0	+ 52	0	52
315	400	+ 89	0	+ 57	0	57
400	500	+ 97	0	+ 63	0	63
500	630	+ 110	0	+ 70	0	70
630	800	+ 125	0	+ 80	0	—

(1) Bore diameter variation in a single radial plane, which is applicable to all radial planes of tapered bores.

7. Bearing Tolerances

Tolerances for Angular Contact Thrust Ball Bearings

Tolerances for angular contact thrust ball bearings (Class 4A ⁽¹⁾) of BAR, BTR, NSKTAC2xF types)

Table 7.14 Inner ring Unit: μm

Nominal Bore Diameter d (mm)	Single Plane Mean Bore Dia. Deviation Δ_{dmp}		Deviation of a Single Bore Dia. Δ_{ds}		Bore Dia. Variation in a Single Radial Plane V_{dp}		Mean Bore Dia. Variation V_{dmp}	Radial Runout of Inner Ring K_{ia}	Inner Ring Runout with Bore S_d	Inner Ring Face Runout with Raceway S_{ia}	Inner Ring Width Variation V_{Bs}	Deviation of Single Inner Ring Width Δ_{Bs}				
												Diameter Series		Single Bearing Combined Bearing	Single Bearing	Combined Bearing ⁽²⁾
												9	0			
Over	Incl.	High	Low	High	Low	Max.	Max.	Max.	Max.	Max.	Max.	High	Low			
—	50	0	− 6	0	− 6	6	5	3	4	4	3	0	− 120	− 120		
50	80	0	− 7	0	− 7	7	5	3.5	4	5	4	0	− 150	− 150		
80	120	0	− 8	0	− 8	8	6	4	5	5	4	0	− 200	− 200		
120	180	0	− 10	0	− 10	10	8	5	6	6	7	5	− 250	− 250		
180	250	0	− 12	0	− 12	12	9	6	8	7	8	6	− 300	− 300		

Table 7.15 Outer ring Unit: μm

Nominal Outside Diameter D (mm)	Single Plane Mean Outside Dia. Deviation Δ_{Dmp}		Deviation of Single Outside Dia. Δ_{Ds}		Outside Dia. Variation in a Single Radial Plane V_{Dp}		Mean Outside Dia. Variation V_{Dmp}	Radial Runout of Outer Ring K_{ea}	Variation of Outside Surface Generatrix Inclination with Face S_D	Outer Ring Face Runout with Raceway S_{ea}	Outer Ring Width Variation V_{Cs}	Deviation of Single Outer Ring Width Δ_{Cs}			
												Diameter Series		High <th rowspan="2">Low </th>	Low
												9	0		
Over	Incl.	High	Low	High	Low	Max.	Max.	Max.	Max.	Max.	Max.	High	Low		
—	80	− 30	− 37	− 30	− 37	7	5	3.5	5	4	5	3	Equal to the value of inner ring (Δ_{Bs}) of the same designation.		
80	120	− 40	− 48	− 40	− 48	8	6	4	6	5	6	4			
120	150	− 50	− 59	− 50	− 59	9	7	5	7	5	7	5			
150	180	− 50	− 60	− 50	− 60	10	8	5	8	5	8	5			
180	250	− 50	− 61	− 50	− 61	11	8	6	10	7	10	7			
250	315	− 60	− 73	− 60	− 73	13	10	7	11	8	10	7			
315	400	− 60	− 80	− 60	− 80	15	11	8	13	10	13	8			

Tolerances for double-direction angular contact thrust ball bearings (Class 7 ⁽³⁾) of NSKTAC2xD type)

Table 7.16 Tolerances of inner ring, outer ring, and bearing height

Nominal Bore Diameter d (mm)	Single Plane Mean Bore Diameter Deviation Δ_{dmp}		Deviation of the Actual Bearing Height Δ_{Ts}		Radial Runout of Assembled Bearing Inner Ring (Outer Ring) K_{ia} (K_{ea})	Inner Ring Runout with Bore S_d	Inner ring (Outer Ring) Face Runout with Raceway S_{ia} (S_{ea})	
								Over
—	30	0	− 5	0	− 300	5	4	3
30	50	0	− 5	0	− 400	5	4	3
50	80	0	− 8	0	− 500	6	5	5
80	120	0	− 8	0	− 600	6	5	5
120	180	0	− 10	0	− 700	8	8	5
180	250	0	− 13	0	− 800	8	8	6
250	315	0	− 15	0	− 900	10	10	6
315	400	0	− 18	0	− 1 200	10	12	7

Table 7.17 Tolerance of outer ring Unit: μm

Nominal Outside Diameter D (mm)	Deviation of Single Outside Dia. Δ_{Ds}	
	Over	Incl.
30	50	− 25
50	80	− 30
80	120	− 36
120	180	− 43
180	250	− 50
250	315	− 56
315	400	− 62
400	500	− 68
500	630	− 76

⁽¹⁾ Class 4 uses NSK specification P4A. It is equivalent to ISO Class 4 for radial bearings excluding the outer ring outside diameter tolerance.

⁽²⁾ Applies to arrangement bearings with rings produced separately.

⁽³⁾ Class 7 uses NSK specification PN7.

⁽⁴⁾ Class 5D uses NSK specification PN5D.

⁽⁵⁾ Class 2B uses NSK specification P2B. Rotational accuracy is equivalent to ISO Class 2 for radial bearings.

Tolerances for Angular Contact Thrust Ball Bearings for Ball Screw Support

Tolerances for high-rigidity angular contact thrust ball bearings (Class 7C of NSKTACxxC type)

Table 7.18 NSKTAC C Series Unit: μm

Nominal Bore (Outer Ring) Diameter (mm)	Single Plane Mean Bore Diameter Deviation Δ_{dmp}		Deviation of Single Bore Diameter Δ_{ds}		Single Plane Mean Outside Diameter Deviation Δ_{Dmp}		Deviation of Single Outside Diameter Δ_{Ds}		Deviation of Single Inner Ring Width Δ_{Bs}			Inner ring (Outer Ring) Face Runout with Raceway S_{ia} (S_{ea})	
									Single Bearing Combined Bearing	Single Bearing	Combined Bearing ⁽²⁾		
													High
Over	Incl.	High	Low	High	Low	High	Low	High	Low		Max.		
10	18	0	− 4	0	− 4	—	—	—	—	0	− 120	− 250	2.5
18	30	0	− 5	0	− 5	—	—	—	—	0	− 120	− 250	2.5
30	50	0	− 6	0	− 6	0	− 6	0	− 6	0	− 120	− 250	2.5
50	80	0	− 7	0	− 7	0	− 7	0	− 7	0	− 150	− 250	2.5
80	120	0	− 8	0	− 8	0	− 8	0	− 8	0	− 200	− 380	2.5

Tolerances for angular contact thrust ball bearings for high-load drive applications (Class 5D ⁽⁴⁾) of NSKTAC0xD and NSKTACxx-3 types)

Table 7.19 NSKTAC 03 Series Unit: μm

Nominal Bore (Outer Ring) Diameter (mm)	Single Plane Mean Bore Diameter Deviation Δ_{dmp}		Single Plane Mean Outside Diameter Deviation Δ_{Dmp}		Deviation of Single Inner Ring Width Δ_{Bs}		Inner ring (Outer Ring) Face Runout with Raceway S_{ia} (S_{ea})	
					High	Low		High
Over	Incl.	High	Low	High	Low	High	Low	Max.
10	18	0	− 5	—	—	0	− 80	5
18	30	0	− 6	—	—	0	− 120	5
30	50	0	− 8	0	− 7	0	− 120	5
50	80	0	− 9	0	− 9	0	− 150	8
80	120	0	− 10	0	− 10	0	− 200	8
120	150	0	− 13	0	− 11	0	− 250	10
150	180	0	− 13	0	− 13	0	− 250	10
180	250	—	—	0	− 15	—	—	10
250	315	—	—	0	− 18	—	—	11
315	400	—	—	0	− 20	—	—	13

Tolerances for BSBD Series double-row bearings (Class P2B ⁽⁵⁾) of BSF and BSN types)

Table 7.20 BSBD Series double-row bearings (BSF and BSN types) Unit: μm

Nominal Bore Diameter (mm)	Single Plane Mean Bore Diameter Deviation Δ_{dmp}		Single Plane Mean Outside Diameter Deviation Δ_{Dmp}		Inner Ring Face Runout with Raceway S_{ia}	Radial Runout of Inner Ring K_{ia}	Width Tolerance		
							High	Low	High
Over	Incl.	High	Low	High	Low	Max.	Max.	High	Low
10	18	0	− 5	0	− 10	1.5	1.5	0	− 250
18	30	0	− 5	0	− 10	2.5	2.5	0	− 250
30	50	0	− 5	0	− 10	2.5	2.5	0	− 250
50	80	0	− 8	0	− 15	2.5	2.5	0	− 250

7. Bearing Tolerances

Tolerances for Metric Design Tapered Roller Bearings

Inner Ring

Table 7.21 Inner ring (Class 5) Unit: μm

Nominal Bore Diameter $d(\text{mm})$		Single Plane Mean Bore Diameter Deviation Δ_{dmp}		Bore Diameter Variation in a Single Radial Plane V_{dp}	Mean Bore Diameter Variation V_{dmp}	Radial Runout of Inner Ring K_{ia}	Inner Ring Runout with Bore S_d
Over	Incl.	High	Low	Max.	Max.	Max.	Max.
10	18	0	-7	5	5	3.5	7
18	30	0	-8	6	5	4	8
30	50	0	-10	8	5	5	8
50	80	0	-12	9	6	5	8
80	120	0	-15	11	8	6	9
120	180	0	-18	14	9	8	10
180	250	0	-22	17	11	10	11
250	315	0	-25	—	—	13	13
315	400	0	-30	—	—	15	15
400	500	0	-35	—	—	18	19

Table 7.22 Inner ring (Class 4) Unit: μm

Nominal Bore Diameter $d(\text{mm})$		Single Plane Mean Bore Diameter Deviation Δ_{dmp}		Deviation of Single Bore Diameter Δ_{ds}		Bore Diameter Variation in a Single Radial Plane V_{dp}	Mean Bore Diameter Variation V_{dmp}	Radial Runout of Inner Ring K_{ia}	Inner Ring Runout with Bore S_d	Inner Ring Face Runout with Raceway S_{ia}
Over	Incl.	High	Low	High	Low	Max.	Max.	Max.	Max.	Max.
10	18	0	-5	0	-5	4	4	2.5	3	3
18	30	0	-6	0	-6	5	4	3	4	4
30	50	0	-8	0	-8	6	5	4	4	4
50	80	0	-9	0	-9	7	5	4	5	4
80	120	0	-10	0	-10	8	5	5	5	5
120	180	0	-13	0	-13	10	7	6	6	7
180	250	0	-15	0	-15	11	8	8	7	8
250	315	0	-18	0	-18	—	—	10	8	10
315	400	0	-23	0	-23	—	—	12	10	14
400	500	0	-27	0	-27	—	—	14	13	17

Remarks: 1. The outside diameter "no-go side" tolerances (low) specified in this table do not necessarily apply within a distance of 1.2 times the chamfer dimension r (max.) from the ring face.
2. Some of the tolerances refer to NSK's own specification.

Outer Ring

Table 7.23 Outer ring (Class 5) Unit: μm

Nominal Outside Diameter $D(\text{mm})$		Single Plane Mean Outside Diameter Deviation Δ_{Dmp}		Outside Diameter Variation in a Single Radial Plane V_{Dp}	Mean Outside Diameter Variation V_{Dmp}	Radial Runout of Outer Ring K_{ea}	Variation of Outside Surface Generatrix Inclination with Face S_D
Over	Incl.	High	Low	Max.	Max.	Max.	Max.
18	30	0	-8	6	5	6	8
30	50	0	-9	7	5	7	8
50	80	0	-11	8	6	8	8
80	120	0	-13	10	7	10	9
120	150	0	-15	11	8	11	10
150	180	0	-18	14	9	13	10
180	250	0	-20	15	10	15	11
250	315	0	-25	19	13	18	13
315	400	0	-28	22	14	20	13
400	500	0	-33	—	—	23	15
500	630	0	-38	—	—	25	18

Table 7.24 Outer ring (Class 4) Unit: μm

Nominal Outside Diameter $D(\text{mm})$		Single Plane Mean Outside Diameter Deviation Δ_{Dmp}		Deviation of Single Outside Diameter Δ_{Ds}		Outside Diameter Variation in a Single Radial Plane V_{Dp}	Mean Outside Diameter Variation V_{Dmp}	Radial Runout of Outer Ring K_{ea}	Variation of Outside Surface Generatrix Inclination with Face S_D	Outer Ring Face Runout with Raceway S_{ea}
Over	Incl.	High	Low	High	Low	Max.	Max.	Max.	Max.	Max.
18	30	0	-6	0	-6	5	4	4	4	5
30	50	0	-7	0	-7	5	5	5	4	5
50	80	0	-9	0	-9	7	5	5	4	5
80	120	0	-10	0	-10	8	5	6	5	6
120	150	0	-11	0	-11	8	6	7	5	7
150	180	0	-13	0	-13	10	7	8	5	8
180	250	0	-15	0	-15	11	8	10	7	10
250	315	0	-18	0	-18	14	9	11	8	10
315	400	0	-20	0	-20	15	10	13	10	13
400	500	0	-23	0	-23	—	—	15	11	15
500	630	0	-28	0	-28	—	—	18	13	18

Remarks: 1. The cylindrical bore diameter "no-go side" tolerance limit (high) specified in this table does not necessarily apply within a distance of 1.2 times the chamfer dimension r (max.) from the ring face.
2. Some of the tolerances refer to NSK's own specification.

Tolerances for Thrust Ball Bearings

Shaft Washer

Table 7.25 Shaft washer (Class 5) Unit: μm

Nominal Bore Diameter $d(\text{mm})$		Single Plane Mean Bore Diameter Deviation Δ_{dmp}		Bore Diameter Variation in a Single Radial Plane V_{dp}	Shaft Washer (Housing Washer) Raceway to Back Face Thickness Variation $S_1(S_e)$	(Reference) Deviation of Bearing Height ΔT_s	
Over	Incl.	High	Low	Max.	Max.	High	Low
18	30	0	-10	8	3	0	-75
30	50	0	-12	9	3	0	-100
50	80	0	-15	11	4	0	-125
80	120	0	-20	15	4	0	-150
120	180	0	-25	19	5	0	-175
180	250	0	-30	23	5	0	-200
250	315	0	-35	26	7	0	-225
315	400	0	-40	30	7	0	-300
400	500	0	-45	34	9	0	-350
500	630	0	-50	38	11	0	-450
630	800	0	-75	—	13	0	-550
800	1000	0	-100	—	15	0	-700
1000	1250	0	-125	—	18	0	-900

Table 7.26 Shaft washer (Class 4) Unit: μm

Nominal Bore Diameter $d(\text{mm})$		Single Plane Mean Bore Diameter Deviation Δ_{dmp}		Bore Diameter Variation in a Single Radial Plane V_{dp}	Shaft Washer (Housing Washer) Raceway to Back Face Thickness Variation $S_1(S_e)$	(Reference) Deviation of Bearing Height ΔT_s	
Over	Incl.	High	Low	Max.	Max.	High	Low
18	30	0	-8	6	2	0	-75
30	50	0	-10	8	2	0	-100
50	80	0	-12	9	3	0	-125
80	120	0	-15	11	3	0	-150
120	180	0	-18	14	4	0	-175
180	250	0	-22	17	4	0	-200
250	315	0	-25	19	5	0	-225
315	400	0	-30	23	5	0	-300
400	500	0	-35	26	6	0	-350
500	630	0	-40	30	7	0	-450
630	800	0	-50	—	8	0	-550

Housing Washer

Table 7.27 Housing washer (Class 5) Unit: μm

Nominal Outside Diameter $D(\text{mm})$		Single Plane Mean Outside Diameter Deviation Δ_{Dmp}		Outside Diameter Variation in a Single Radial Plane V_{Dp}
Over	Incl.	High	Low	Max.
30	50	0	-16	12
50	80	0	-19	14
80	120	0	-22	17
120	180	0	-25	19
180	250	0	-30	23
250	315	0	-35	26
315	400	0	-40	30
400	500	0	-45	34
500	630	0	-50	38
630	800	0	-75	55
800	1000	0	-100	75
1000	1250	0	-120	—
1250	1600	0	-160	—

Table 7.28 Housing washer (Class 4) Unit: μm

Nominal Outside Diameter $D(\text{mm})$		Single Plane Mean Outside Diameter Deviation Δ_{Dmp}		Outside Diameter Variation in a Single Radial Plane V_{Dp}
Over	Incl.	High	Low	Max.
30	50	0	-9	7
50	80	0	-11	8
80	120	0	-13	10
120	180	0	-15	11
180	250	0	-20	15
250	315	0	-25	19
315	400	0	-28	21
400	500	0	-33	25
500	630	0	-38	29
630	800	0	-45	34

Fitting of Shafts and Housings

In order to take full advantage of the capabilities of super precision bearings such as running accuracy, high-speed performance, and low heat generation, a high level of accuracy is required of shafts, housings and other surrounding parts as well.

When the inner ring or outer ring is mounted onto a shaft or into a housing with interference, the shape of the shaft or the housing (out-of-roundness) is transferred to the bearing raceway surfaces and will affect running accuracy. When multiple angular contact ball bearings are used in combination, cylindricity affects the distribution of preload between the bearings. Therefore, the parts that mate with bearing surfaces should be as accurate as possible. Inaccurate mating of parts may cause the formation of peaks or ridges along the shaft, which can affect the quality of finished work, especially in precision lathes etc.

Tables 8.1 through 8.4 list recommended interference values for bearings operated in standard conditions at speeds of less than 800 000 $d_m n$ (Tables 8.1 and 8.2 refer to bearings for machine tool spindles, Tables 8.3 and 8.4 refer to ball screw support bearings).

For thrust cylindrical roller bearings and thrust ball bearings, we recommend a shaft fit of h6 and a housing fit of G7 as a target. Clearance fits are commonly used for both shaft washer and housing washer. However, particularly in the case of thrust ball bearings where alignment of both washers with the shaft is required, small values are preferable within the range that assembly allows.

Table 8.1 Fits on Shafts

Bearing type	Shaft Outside diameter (mm)		Tolerance of shaft outside diameter (mm)		Target interference ^(*) ([°]) (mm)	
	Over	Incl.	Min.	Max.	Min.	Max.
Bearings for machine tool spindles	10	18	- 0.003	0	0	0.002T
	18	50	- 0.004	0	0	0.003T
	50	80	- 0.005	0	0	0.003T
	80	120	- 0.003	0.003	0	0.004T
	120	180	- 0.004	0.004	0	0.006T
	180	250	- 0.005	0.005	0	0.008T
	250	315	- 0.008	0.008	0	0.010T
	315	400	- 0.009	0.009	0	0.013T
	400	500	- 0.010	0.010	0	0.015T

(*) Use the target interference when the bearing can be matched to the shaft or housing. Otherwise, use the shaft outside diameter and housing bore minimum and maximum for custom matching.

([°]) T=Interference or tight fit; L=Clearance or loose fit

([°]) Only applicable if outer ring is inserted into housing separately.

Table 8.2 Fits on Housings

Bearing type	Housing Bore diameter (mm)		Tolerance of housing bore (mm)		Target interference ^(*) ([°]) (mm)	
	Over	Incl.	Min.	Max.	Min.	Max.
Angular contact ball bearings (Fixed end)	18	50	- 0.002	0.002	0.002L	0.005L
	50	80	- 0.0025	0.0025	0.002L	0.005L
	80	120	- 0.003	0.003	0.002L	0.006L
	120	180	- 0.004	0.004	0.003L	0.009L
	180	250	- 0.005	0.005	0.004L	0.012L
	250	315	- 0.006	0.006	0.005L	0.015L
	315	400	- 0.007	0.007	0.007L	0.02L
	400	500	- 0.008	0.008	0.008L	0.023L
	500	630	- 0.008	0.008	0.008L	0.024L
	630	800	- 0.009	0.009	0.009L	0.027L
Angular contact thrust ball bearings (if used together with radial bearings)	50	80	- 0.005	0	0.025L	0.037L
	80	120	- 0.007	0	0.033L	0.047L
	120	150	- 0.008	0	0.042L	0.059L
	150	180	- 0.011	0	0.039L	0.059L
	180	250	- 0.012	0	0.038L	0.061L
	250	315	- 0.013	0	0.047L	0.073L
	315	400	- 0.015	0	0.045L	0.080L
	400	500	- 0.016	0	0.054L	0.091L
	500	630	- 0.018	0	0.052L	0.094L
Angular contact ball bearings (Free end)	18	50	0.004	0.007	0.006L	0.009L
	50	80	0.005	0.008	0.007L	0.01L
	80	120	0.006	0.010	0.008L	0.012L
	120	180	0.008	0.014	0.011L	0.017L
	180	250	0.010	0.018	0.014L	0.022L
	250	315	0.012	0.022	0.017L	0.027L
	315	400	0.013	0.026	0.021L	0.034L
	400	500	0.015	0.030	0.024L	0.039L
	500	630	0.016	0.032	0.026L	0.042L
	630	800	0.018	0.036	0.031L	0.049L
Cylindrical roller bearings, Tapered roller bearings ([°])	50	80	- 0.005	0	0.002L	0.002T
	80	120	- 0.007	0	0.002L	0.002T
	120	180	- 0.008	0	0.003L	0.003T
	180	250	- 0.011	0	0.004L	0.004T
	250	315	- 0.012	0	0.005L	0.005T
	315	400	- 0.013	0	0.007L	0.007T
	400	500	- 0.015	0	0.008L	0.008T
	500	630	- 0.016	0	0.008L	0.008T
630	800	- 0.018	0	0.009L	0.009T	

8. Design of Shafts and Housings

Recommended interference values for standard operating conditions of ball screws are listed in Tables 8.3 and 8.4.

When using angular contact thrust ball bearings for high-load drive ball screw support, in cases where a single end is supported and moment loads are high, it is advisable to increase shaft interference, for example by choosing k5 etc. as required.

For super precision class applications please make sure during designing and mounting that:

Misalignment in inclination is below 1/2000 (target: below 1/5000)

Eccentricity is below 0.020mm

Table 8.3 Fits on Shafts

Bearing type	Shaft Outside Diameter (mm)		Tolerance of Shaft Outside Diameter (mm)		
	Over	Incl.		Min.	Max.
Angular contact thrust ball bearings for ball screw support in machine tools	10	18	h5	- 0.008	0
	18	30		- 0.009	0
	30	50		- 0.011	0
	50	80		- 0.013	0
	80	120		- 0.015	0
Angular contact thrust ball bearings for ball screw support in high-load drive applications	10	18	js5	- 0.004	0.004
	18	30		- 0.0045	0.0045
	30	50		- 0.0055	0.0055
	50	80		- 0.0065	0.0065
	80	120		- 0.0075	0.0075

Table 8.4 Fits on Housings

Bearing type	Housing Bore Diameter (mm)		Tolerance of Housing Bore Diameter (mm)		
	Over	Incl.		Min.	Max.
Angular contact thrust ball bearings for ball screw support	30	50	H6	0	0.016
	50	80		0	0.019
	80	120		0	0.022
	120	180		0	0.025
	180	250		0	0.029
	250	315		0	0.032

Fig. 8.1 Arrangement of Ball Screw Support Bearings (Example)

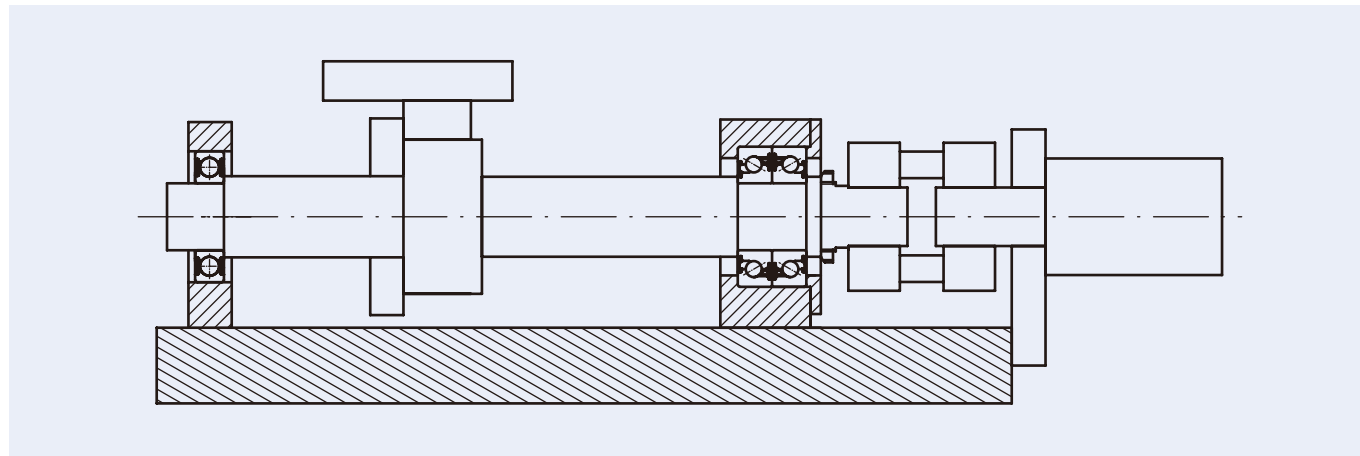

Recommended accuracy and surface roughness for bearing seats in machine tool spindle applications are shown in the tables below.

When using cylindrical roller bearings with tapered bores, if the taper of the inner ring does not match that of the shaft, misalignment of the inner ring groove will cause irregular movement of the rollers. With double-row cylindrical roller bearings, a difference in residual clearance between the rows will occur. Consequently, load will not be sustained equally, and rigidity will decline.

We recommend that you gauge the tapered parts to be mated with bearings. Contact should cover more than 80% of the total surface area that is dyed blue. Please refer to page 248 for a description and details on the gauging of shaft tapers.

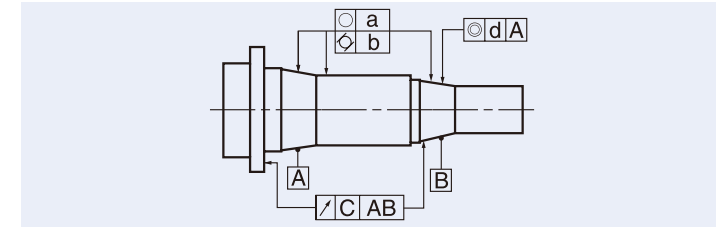

Table 8.5 Tolerance for and Mean Roughness of Shafts

Shaft Diameter (mm)		Tolerance Grades and Mean Roughness (μm)							
		Out-of-roundness (○)		Cylindricity (⊂)	Runout (⤵)		Coaxiality (◎)		Roughness
		a		b	c		d		R _a
Over	Incl.	Bearing Accuracy		Bearing Accuracy	Bearing Accuracy		Bearing Accuracy		Bearing Accuracy
		P5	P4,P3,P2	All accuracy classes	P5	P4,P3,P2	P5	P4,P3,P2	All accuracy classes
—	10	0.7	0.5	0.7	2	1.2	4	2.5	0.2
10	18	1	0.6	1	2.5	1.5	5	3	0.2
18	30	1.2	0.7	1.2	3	2	6	4	0.2
30	50	1.2	0.7	1.2	3.5	2	7	4	0.2
50	80	1.5	1	1.5	4	2.5	8	5	0.2
80	120	2	1.2	2	5	3	10	6	0.4
120	180	2.5	1.7	2.5	6	4	12	8	0.4
180	250	3.5	2.2	3.5	7	5	14	10	0.4
250	315	4	3	4	8	6	16	12	0.4
315	400	4.5	3.5	4.5	9	6.5	18	13	0.8
400	500	5	4	5	10	7.5	20	15	0.8

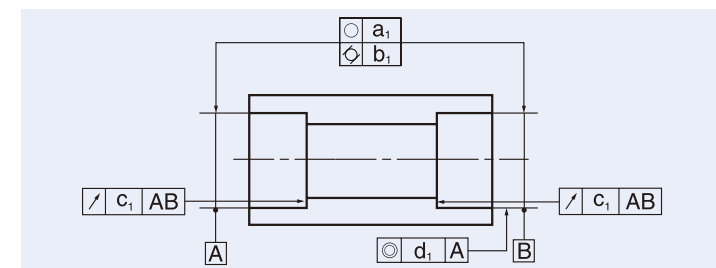
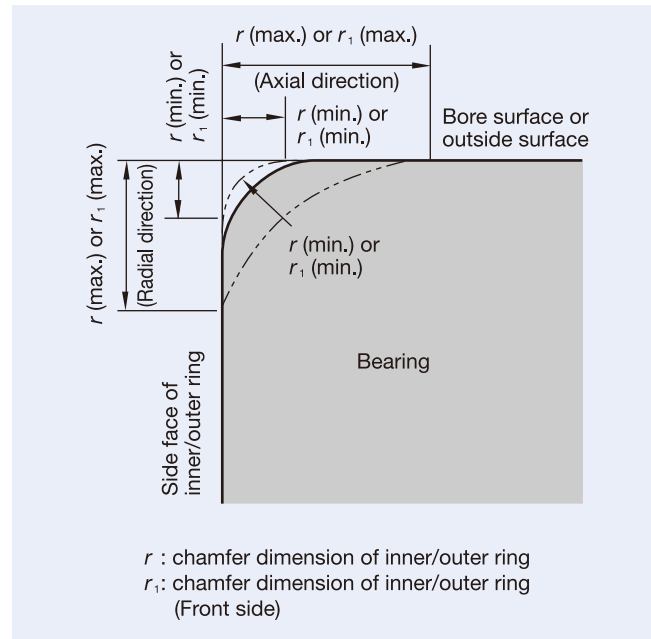

Table 8.6 Tolerance for and Mean Roughness of Housings

Housing Bore Diameter (mm)		Tolerance Grades and Mean Roughness (μm)							
		Out-of-roundness (○)		Cylindricity (⊂)	Runout (⤵)		Coaxiality (◎)		Roughness
		a ₁		b ₁	c ₁		d ₁		R _a
Over	Incl.	Bearing Accuracy		Bearing Accuracy	Bearing Accuracy		Bearing Accuracy		Bearing Accuracy
		P5	P4,P3,P2	All accuracy classes	P5	P4,P3,P2	P5	P4,P3,P2	All accuracy classes
10	18	1	0.6	1	2.5	1.5	5	3	0.4
18	30	1.2	0.7	1.2	3	2	6	4	0.4
30	50	1.2	0.7	1.2	3.5	2	7	4	0.4
50	80	1.5	1	1.5	4	2.5	8	5	0.4
80	120	2	1.2	2	5	3	10	6	0.8
120	180	2.5	1.7	2.5	6	4	12	8	0.8
180	250	3.5	2.2	3.5	7	5	14	10	0.8
250	315	4	3	4	8	6	16	12	1.6
315	400	4.5	3.5	4.5	9	6.5	18	13	1.6
400	500	5	4	5	10	7.5	20	15	1.6
500	630	5.5	4.5	5.5	11	8	22	16	1.6
630	800	6.5	5	6.5	12.5	9	25	18	1.6

Chamfer Dimension Limits and Corner Radius of Shaft or Housing

Fig. 8.2 Chamfer Dimension



Remarks: The precise shape of chamfer surfaces has not been specified but its profile in the axial plane shall not intersect an arc of radius r (min.) or r_1 (min.) touching the side face of an inner ring and the bore surface, or the side face of an outer ring and the outside surface.

Table 8.7 Chamfer Dimension Limits for Radial Bearings (excluding Tapered Roller Bearings)

Smallest permissible chamfer dimension	Nominal bore diameter d		Largest permissible chamfer dimension		For reference Corner radius of shaft or housing r_a
	Over	Incl.	Radial direction	Axial direction (°)	
r (min.) or r_1 (min.)					
0.15	—	—	0.3	0.6	0.15
0.3	—	40	0.6	1	0.3
0.3	40	—	0.8	1	0.3
0.6	—	40	1	2	0.6
0.6	40	—	1.3	2	0.6
1	—	50	1.5	3	1
1	50	—	1.9	3	1
1.1	—	120	2	3.5	1
1.1	120	—	2.5	4	1
1.5	—	120	2.3	4	1.5
1.5	120	—	3	5	1.5
2	—	80	3	4.5	2
2	80	220	3.5	5	2
2	220	—	3.8	6	2
2.1	—	280	4	6.5	2
2.1	280	—	4.5	7	2
2.5	—	100	3.8	6	2
2.5	100	280	4.5	6	2
2.5	280	—	5	7	2
3	—	280	5	8	2.5
3	280	—	5.5	8	2.5
4	—	—	6.5	9	3
5	—	—	8	10	4
6	—	—	10	13	5

Table 8.8 Chamfer Dimension Limits for Tapered Roller Bearings

Smallest permissible chamfer dimension	Nominal bore diameter or nominal outside diameter d or D		Largest permissible chamfer dimension		For reference Corner radius of shaft or housing r_a
	Over	Incl.	Radial direction	Axial direction (°)	
r (min.)					
0.6	—	40	1.1	1.7	0.6
0.6	40	—	1.3	2	0.6
1	—	50	1.6	2.5	1
1	50	—	1.9	3	1
1.5	—	120	2.3	3	1.5
1.5	120	250	2.8	3.5	1.5
1.5	250	—	3.5	4	1.5
2	—	120	2.8	4	2
2	120	250	3.5	4.5	2
2	250	—	4	5	2
2.5	—	120	3.5	5	2
2.5	120	250	4	5.5	2
2.5	250	—	4.5	6	2
3	—	120	4	5.5	2.5
3	120	250	4.5	6.5	2.5
3	250	400	5	7	2.5
3	400	—	5.5	7.5	2.5
4	—	120	5	7	3
4	120	250	5.5	7.5	3
4	250	400	6	8	3
4	400	—	6.5	8.5	3
5	—	180	6.5	8	4
5	180	—	7.5	9	4
6	—	180	7.5	10	5
6	180	—	9	11	5

(°) For inner ring chamfer, locate d in "Over"/"Incl." columns; for outer ring chamfer, locate D in "Over"/"Incl." columns.

Table 8.9 Chamfer Dimension Limits for Thrust Bearings

Smallest permissible chamfer dimension	Largest permissible chamfer dimension r (max.)	For reference Corner radius of shaft or housing r_a	
			Radial and axial direction
r (min.) or r_1 (min.)			
0.6	1.5	0.6	
1	2.2	1	
1.1	2.7	1	
1.5	3.5	1.5	
2	4	2	
2.1	4.5	2	
3	5.5	2.5	
4	6.5	3	
5	8	4	
6	10	5	
7.5	12.5	6	
9.5	15	8	
12	18	10	
15	21	12	
19	25	15	

Spacer Dimensions

The dimensions of standard spacers for open type angular contact ball bearings (19, 29, 10, 20 and 02 Series) are listed below.

Additional information:

Material of spacer: Bearing steel or carbon steel

When using spacers, parallelism of spacer end surfaces should be:

Less than 0.003 mm (for spacers up to 300mm bore size)

Less than 0.004 mm (for spacers over 300mm bore size)

19 or 29 Series

Standard spacers for dimension series 19 or 29 (79, BNR19, BER19, BNR29, BER29, BSR19)

Unit: mm

Bore number	Nominal bearing bore diameter d	Bearing outside diameter D	Outer ring spacer		Inner ring spacer		Spacer chamfer
			Outside diameter (°)	Bore diameter	Outside diameter	Bore diameter (°)	
00	10	22	21.5	17.5	14.5	10.5	0.2
01	12	24	23.5	19.5	16.5	12.5	0.2
02	15	28	27.5	23.5	19.5	15.5	0.2
03	17	30	29.5	25.5	21.5	17.5	0.2
04	20	37	36.5	31.5	26	20.5	0.2
05	25	42	41.5	36	31	25.5	0.2
06	30	47	46.5	41	36	30.5	0.2
07	35	55	54.5	48	42	35.5	0.3
08	40	62	61.5	54.5	47.5	40.5	0.3
09	45	68	67.5	60	53	45.5	0.3
10	50	72	71.5	66	56	50.5	0.3
11	55	80	79.5	72	64	55.5	0.5
12	60	85	84.5	77	68	60.5	0.5
13	65	90	89.5	82	73	65.5	0.5
14	70	100	99.5	91.5	79	70.5	0.5
15	75	105	104.5	96.5	84	75.5	0.5
16	80	110	109.5	101.5	89.5	80.5	0.5
17	85	120	119.5	110	95	85.5	0.5
18	90	125	124.2	116	100	90.5	0.5
19	95	130	129.2	120	106	95.5	0.5
20	100	140	139.2	129	112	100.5	0.5
21	105	145	144.2	133	117	105.5	0.5
22	110	150	149.2	138	122	110.5	0.5
24	120	165	164.2	152	133	120.5	0.5
26	130	180	179.2	166	144	130.8	0.8
28	140	190	189.2	176	154	140.8	0.8
30	150	210	209.2	193	167	150.8	1.0
32	160	220	219.2	203	175	160.8	1.0
34	170	230	229.2	214	188	170.8	1.0
36	180	250	249.2	231	200	180.8	1.0
38	190	260	259.2	242	206	190.8	1.0
40	200	280	279.2	255	225	200.8	1.0
44	220	300	299.2	275	245	220.8	1.2
48	240	320	319.2	297	263	240.8	1.2
52	260	360	359.2	322	290	260.8	1.2
56	280	380	379.2	348	312	280.8	1.2
60	300	420	419.2	386	335	300.8	1.2
64	320	440	439.2	400	360	320.8	1.2
68	340	460	459.2	425	375	340.8	1.2
72	360	480	479.2	441	399	360.8	1.2
76	380	520	519.2	475	425	380.8	1.5
80	400	540	539.2	494	446	400.8	1.5

(°) For outer ring spacers operated using oil mist lubrication or jet lubrication, we recommend that the outside diameter of the outer ring spacer is the same as the bearing outside diameter, with a tolerance of g5 or better.

(°) For high-speed operations exceeding 700 000 $d_m n$, we recommend that the bore diameter of the inner ring spacer is the same as the bearing bore diameter, with a tolerance of F6 or better.

Additional information:

Material of spacer: Bearing steel or carbon steel

When using spacers, parallelism of spacer end surfaces should be:

Less than 0.003 mm (for spacers up to 300mm bore size)

Less than 0.004 mm (for spacers over 300mm bore size)

10 or 20 Series

Standard spacers for dimension series 10 or 20 (70, BNR10, BER10, BNR20, BER20, BSR10, BNRD10, BERD10) Unit: mm

Bore number	Nominal bearing bore diameter d	Bearing outside diameter D	Outer ring spacer		Inner ring spacer		Spacer chamfer
			Outside diameter ⁽¹⁾	Bore diameter	Outside diameter	Bore diameter ⁽²⁾	
00	10	26	25.5	21.5	14.5	10.5	0.2
01	12	28	27.5	23.5	17	12.5	0.2
02	15	32	31.5	27	20	15.5	0.2
03	17	35	34.5	29.5	23	17.5	0.2
04	20	42	41.5	35	27	20.5	0.3
05	25	47	46.5	40.5	32	25.5	0.3
06	30	55	54.5	47.5	38	30.5	0.5
07	35	62	61.5	54	43	35.5	0.5
08	40	68	67.5	60	48	40.5	0.5
09	45	75	74.5	66	55	45.5	0.5
10	50	80	79.5	71	60	50.5	0.5
11	55	90	89.5	81	66	55.5	0.5
12	60	95	94.5	86	69	60.5	0.5
13	65	100	99.5	91	74	65.5	0.5
14	70	110	109.5	98	83	70.5	0.5
15	75	115	114.5	105	85	75.5	0.5
16	80	125	124.2	112	93	80.5	0.5
17	85	130	129.2	117	99	85.5	0.5
18	90	140	139.2	126	104	90.5	0.8
19	95	145	144.2	131	109	95.5	0.8
20	100	150	149.2	136	114	100.5	0.8
21	105	160	159.2	144	121	105.5	1.0
22	110	170	169.2	153	128	110.5	1.0
24	120	180	179.2	166	136	120.5	1.0
26	130	200	199.2	177	150	130.8	1.0
28	140	210	209.2	190	160	140.8	1.0
30	150	225	224.2	203	172	150.8	1.2
32	160	240	239.2	217	183	160.8	1.2
34	170	260	259.2	230.5	199.5	170.8	1.2
36	180	280	279.2	250	210	180.8	1.2
38	190	290	289.2	261	221	190.8	1.2
40	200	310	309.2	278	232	200.8	1.2
44	220	340	339.2	305	255	220.8	1.2
48	240	360	359.2	325	275	240.8	1.2
52	260	400	399.2	345	304	260.8	1.5
56	280	420	419.2	380	320	280.8	1.5
60	300	460	459.2	412	352	300.8	1.5
64	320	480	479.2	440	360	320.8	1.5
68	340	520	519.2	470	390	340.8	2.0
72	360	540	539.2	490	410	360.8	2.0
76	380	560	559.2	502	438	380.8	2.0
80	400	600	599.2	536	464	400.8	2.0

⁽¹⁾ For outer ring spacers operated using oil mist lubrication or jet lubrication, we recommend that the outside diameter of the outer ring spacer is the same as the bearing outside diameter, with a tolerance of g5 or better.

⁽²⁾ For high-speed operations exceeding 700 000 $d_m n$, we recommend that the bore diameter of the inner ring spacer is the same as the bearing bore diameter, with a tolerance of F6 or better.

02 Series

Standard spacers for dimension series 02 (72, BSR02) Unit: mm

Bore number	Nominal bearing bore diameter d	Bearing outside diameter D	Outer ring spacer		Inner ring spacer		Spacer chamfer
			Outside diameter ⁽¹⁾	Bore diameter	Outside diameter	Bore diameter ⁽²⁾	
00	10	30	29.5	25	17	10.5	0.3
01	12	32	31.5	27	18	12.5	0.3
02	15	35	34.5	29	21	15.5	0.3
03	17	40	39.5	33	24	17.5	0.3
04	20	47	46.5	39	28	20.5	0.5
05	25	52	51.5	44	33	25.5	0.5
06	30	62	61.5	53	40	30.5	0.5
07	35	72	71.5	62	46	35.5	0.5
08	40	80	79.5	68	52	40.5	0.5
09	45	85	84.5	75	56	45.5	0.5
10	50	90	89.5	80	60	50.5	0.5
11	55	100	99.5	90	65	55.5	0.8
12	60	110	109.5	95	75	60.5	0.8
13	65	120	119.5	105	80	65.5	0.8
14	70	125	124.2	110	85	70.5	0.8
15	75	130	129.2	115	90	75.5	0.8
16	80	140	139.2	125	95	80.5	1.0
17	85	150	149.2	135	105	85.5	1.0
18	90	160	159.2	140	110	90.5	1.0
19	95	170	169.2	150	115	95.5	1.0
20	100	180	179.2	160	125	100.5	1.0
21	105	190	189.2	170	132	105.5	1.0
22	110	200	199.2	175	135	110.5	1.0
24	120	215	214.2	190	145	120.5	1.0
26	130	230	229.2	203	157	130.8	1.2
28	140	250	249.2	220	170	140.8	1.2
30	150	270	269.2	233	189	150.8	1.2
32	160	290	289.2	255	195	160.8	1.2
34	170	310	309.2	270	210	170.8	1.5
36	180	320	319.2	277	223	180.8	1.5
38	190	340	339.2	300	235	190.8	1.5
40	200	360	359.2	320	250	200.8	1.5

⁽¹⁾ For outer ring spacers operated using oil mist lubrication or jet lubrication, we recommend that the outside diameter of the outer ring spacer is the same as the bearing outside diameter, with a tolerance of g5 or better.

⁽²⁾ For high-speed operations exceeding 700 000 $d_m n$, we recommend that the bore diameter of the inner ring spacer is the same as the bearing bore diameter, with a tolerance of F6 or better.

Nozzle Position

The following table lists nozzle positions for oil-air, oil mist, and oil jet lubrication systems.

Unit: mm

Bore number	Nominal bearing bore	79 Series		70 Series		72 Series		N10XXMR (Standard Series)		N10XXR (NSKROBUST Series)	
		ϕA (°)	B	ϕA (°)	B	ϕA	B	ϕA	B	ϕA	B
00	10	14.5	0.4	16.1	0.5	18.1	0.5	—	—	—	—
01	12	16.5	0.4	18.3	0.5	19.6	0.5	—	—	—	—
02	15	20.0	0.5	21.3	0.5	22.6	0.7	—	—	—	—
03	17	21.8	0.5	23.5	1.0	25.9	0.7	—	—	—	—
04	20	26.1	0.5	28.2	1.0	30.5	1.0	—	—	—	—
05	25	31.1	0.5	32.9	1.0	35.5	1.0	—	—	—	—
06	30	36.1	0.5	39.5	1.0	41.8	1.0	39.7	1.2	—	—
07	35	42.6	0.5	44.6	1.0	48.6	0.7	45.4	1.5	—	—
08	40	47.9	0.5	50.0	1.0	54.6	0.7	50.6	1.5	—	—
09	45	53.4	0.5	55.6	1.0	59.4	0.7	56.5	2.0	60.0	1.2
10	50	57.9	0.5	60.6	1.0	64.4	1.0	61.5	2.0	64.5	1.3
11	55	64.0	0.5	67.3	1.0	70.8	1.0	69.2	2.5	71.0	1.2
12	60	69.0	0.5	72.5	1.0	77.4	0.7	74.3	2.5	76.5	1.2
13	65	74.0	0.5	77.5	1.0	84.6	0.7	79.2	2.5	81.5	1.2
14	70	80.9	0.7	83.7	1.0	89.4	0.7	86.6	3.0	89.0	1.5
15	75	85.5	0.7	89.4	1.0	94.5	0.7	90.0	2.5	94.5	1.5
16	80	90.5	0.7	96.5	1.0	101.4	0.7	98.5	3.0	101.0	2.0
17	85	98.8	0.7	101.5	1.0	109.8	1.0	103.5	3.0	106.0	2.0
18	90	102.8	0.7	108.6	1.0	116.7	1.0	109.0	3.0	—	—
19	95	107.7	0.7	113.3	1.0	123.6	1.0	115.5	2.5	—	—
20	100	116.0	0.7	118.6	1.0	130.6	1.0	119.0	2.5	—	—
21	105	119.5	0.7	125.1	0.7	137.4	1.0	125.5	3.0	—	—
22	110	124.5	0.7	131.9	0.7	144.4	1.0	134.0	3.0	—	—
24	120	136.3	0.7	142.3	0.7	156.3	1.0	142.0	3.0	—	—
26	130	149.3	0.7	156.2	1.0	168.9	1.0	156.1	4.5	—	—
28	140	158.1	0.7	165.7	2.5	182.6	1.0	168.0	4.5	—	—
30	150	171.8	0.7	178.1	2.5	196.5	1	—	—	—	—
32	160	181.8	0.7	190.4	2.5	210	1	190	5	—	—
34	170	191.8	0.7	203.4	2.5	223	1	203	5	—	—
36	180	205.6	0.7	217.1	2.5	233	1	—	—	—	—
38	190	215.4	0.7	227.1	2.5	248	1	—	—	—	—
40	200	229	0.7	240.9	2.5	262	1	242	6.5	—	—
44	220	249	0.7	264.3	5	290	1.5	—	—	—	—
48	240	271.4	0.7	287	5	320	2	—	—	—	—

(°) ϕA of 79 and 70 Series bearings are in compliance with DIN Standard 628-6.

Note

- Positioning the nozzle parallel to the spindle axis is sufficient for normal operating speeds. For bearings usually operated at high speeds, it is advantageous to position the nozzle bore so that the lubricant is directed into the bearing at an angle of about 15° to 20°.
- An appropriate oil drain is necessary to prevent oil from accumulating in the spindle which leads to increased heat in the sliding sections and damages bearings.
- We recommend filtering the oil to 5 micron or less before it enters the lubrication system. Refer to page 220 for an example of an oil-air lubrication system.

Fig. 9.1 Angle of Spray Nozzle

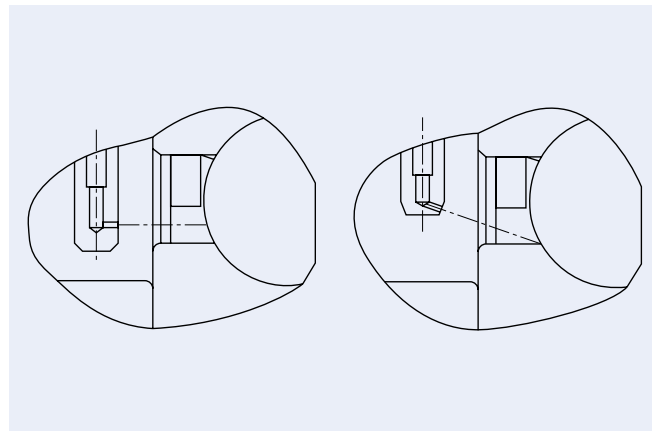

Unit: mm

Nominal bearing bore	BNR19 BER19		BNR10 BER10 BNRD10 BERD10		BSR19		BSR10		BSR02		BAR10 BTR10	
	ϕA	B	ϕA	B	ϕA	B	ϕA	B	ϕA	B	ϕA	B
6	—	—	—	—	—	—	9.0	0.4	—	—	—	—
7	—	—	—	—	—	—	10.5	0.4	—	—	—	—
8	—	—	—	—	—	—	12.0	0.5	—	—	—	—
10	—	—	—	—	13.5	0.4	14.5	0.5	17.0	1.0	—	—
12	—	—	—	—	15.5	0.4	16.5	0.5	18.0	0.5	—	—
15	—	—	—	—	18.5	0.5	20.0	1.0	21.0	1.0	—	—
17	—	—	—	—	20.5	0.5	22.5	1.5	24.0	0.5	—	—
20	—	—	—	—	25.0	0.8	26.5	0.8	28.3	0.5	—	—
25	31.0	0.5	—	—	30.0	0.8	31.5	0.8	33.2	1.0	—	—
30	35.5	0.5	39.0	1.0	—	—	—	—	—	—	—	—
35	42.0	0.5	44.5	1.2	—	—	—	—	—	—	—	—
40	48.0	0.5	50.0	1.5	—	—	—	—	—	—	—	—
45	53.0	0.5	55.5	1.7	—	—	—	—	—	—	—	—
50	57.5	0.5	60.5	1.7	—	—	—	—	—	—	60.5	0.9
55	63.5	0.5	67.5	1.5	—	—	—	—	—	—	67.5	0.7
60	68.5	0.5	73.0	1.5	—	—	—	—	—	—	73.5	0.7
65	73.5	0.5	77.5	1.5	—	—	—	—	—	—	77.5	0.7
70	80.5	0.7	84.0	1.7	—	—	—	—	—	—	84.0	0.7
75	85.0	0.7	89.0	1.7	—	—	—	—	—	—	89.0	0.7
80	90.5	0.7	96.0	1.7	—	—	—	—	—	—	96.0	0.9
85	98.5	0.7	102.0	1.7	—	—	—	—	—	—	102.0	0.9
90	102.0	0.7	109.0	1.7	—	—	—	—	—	—	108.5	1.2
95	107.0	0.7	112.0	1.7	—	—	—	—	—	—	112.5	1.2
100	113.5	0.7	118.5	2.5	—	—	—	—	—	—	118.5	1.7
105	119.0	0.7	125.0	1.7	—	—	—	—	—	—	126.0	1.4
110	124.0	0.7	132.5	1.7	—	—	—	—	—	—	132.5	1.2
120	136.0	0.7	143.0	1.7	—	—	—	—	—	—	142.5	1.2
130	149.0	0.7	156.5	1.7	—	—	—	—	—	—	155.5	1.7
140	157.5	0.7	166.0	1.7	—	—	—	—	—	—	167	1.7
150	171.5	0.7	178.5	1.7	—	—	—	—	—	—	179.5	1.9
160	181.8	0.7	190	2	—	—	—	—	—	—	190	2.0
170	191.8	0.7	—	—	—	—	—	—	—	—	205	1.7
180	205.6	0.7	—	—	—	—	—	—	—	—	218	2.0
190	215.4	0.7	—	—	—	—	—	—	—	—	228	2.0
200	229	0.7	—	—	—	—	—	—	—	—	242	2.2

Fig. 9.2 Position and Direction of Spray Nozzle

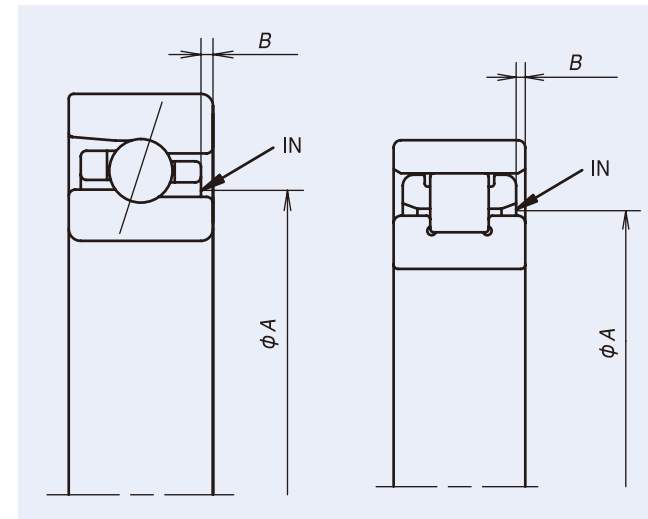



Bearing Handling

- 1. Mounting244-265
 - 1. Cleaning the Bearings and Related Parts
 - 2. Checking Dimensions of Related Parts
 - 3. Mounting Procedures
 - 4. Inspection after Mounting
- 2. Operational Inspection266-267
- 3. Running-in Procedures268-269

Mounting

Operating Inspection

Running-in Procedures

Mounting

The method of mounting rolling bearings strongly affects their accuracy, life, and performance. We recommended that designers and engineers fully analyze the handling procedures for bearings and establish standards with regard to the following procedures:

- (1) Cleaning the bearings and related parts
- (2) Checking the dimensions of related parts
- (3) Mounting procedures
- (4) Inspection after mounting

Precautions for Proper Handling of Bearings

Super precision bearings are highly accurate, high-quality machine parts and must be handled accordingly. Even if high-performance, high-accuracy bearings are used, their expected performance cannot be achieved if they are not handled properly. The main precautions to be observed are as follows:

■ Keep bearings and surrounding area clean

Foreign particles, even if invisible to the naked eye, have harmful effects on bearings. Take care to prevent the ingress of dirt and debris into the bearing by maintaining a clean working environment.

■ Handle bearings carefully

Avoid any heavy shocks during handling. Shock loads can scratch or dent a bearing, possibly resulting in failure. Excessive impacts may cause brinelling or cracks. Even very small damage can lead to noise and should be avoided.

■ Use proper tools

Always use the proper equipment when handling bearings and avoid general-purpose tools.

■ Prevent corrosion

Handling bearings with bare hands can corrode the bearing surfaces because of perspiration or various other contaminants on the skin. Wear gloves if possible. Take measures to prevent bearings rusting due to corrosive gasses.

Storage method

■ Although bearings are coated with an anti-corrosion agent, and then wrapped and packed, it is impossible to completely avoid exposure to the air surrounding the bearings. Store the bearings in a dry location and avoid exposure to moisture and humidity.

■ Bearings should be stored in a clean, dry, and well-ventilated location that also provides protection from direct sunlight. Store the bearings in a locker or on shelves that are at least 30 cm from the floor.

■ When bearings are unpacked for acceptance inspection, take measures to prevent rusting and contamination. After inspection, follow the guidelines given above to ensure proper storage.

1. Cleaning the Bearings and Related Parts

Bearings should not be unpacked until immediately before mounting. Delivered bearings are coated with an anti-corrosion agent for dustproofing and rust prevention during transportation. In general, bearings for high-speed operation should be cleaned with clean filtered solvent to remove the anti-corrosion agent. That applies in particular to bearings that need packing with grease: anti-corrosion agent remaining on the raceway surfaces may lead to grease outflow. After the bearings are cleaned with filtered solvent, they should be protected to prevent corrosion. Refer to pages 246-247 for a detailed description of the cleaning process.

Some products such as bearings prepacked with grease or sealed bearings do not require cleaning. Instead wipe off the anti-corrosion agent from the outside surface with a clean cloth before assembly.

Shafts and housings should be cleaned and the mating surfaces (bearing seats, spacer seats) checked for flaws or burrs.

2. Checking the Dimensions of Related Parts

Inspection of shaft and housing

■ Dimensions of the shafts and housing bores should be checked to confirm the required fit with the bearing bore and outside diameter will be achieved. Refer to pages 232-234 for recommended fits on shafts and housings.

■ Measurements should be taken in a thermostatic chamber (this applies to mounting, as well). Once the parts have reached a constant and stable temperature, take measurements using a micrometer or cylinder gauge. Always take measurements at several different points and confirm there are no significant differences in measurement values. Recommended accuracy values for shafts and housings are listed on page 235.

■ For spacers etc. to be arranged on a spindle, we recommend a parallelism of 0.003 mm or less (0.004 mm or less for bore sizes larger than 300 mm). Spacer parallelism exceeding this recommendation will tilt the bearings causing inaccuracies and bearing noise.

■ To control radial clearance of cylindrical roller bearings with tapered bores, measure each dimension (before packing grease, in the case of grease lubrication) and prepare the spacers accordingly. Radial clearance measurement and clearance adjustment method are explained on page 249.

3. Mounting Procedures

When using grease lubrication, pack bearings with grease before mounting. With oil-air and oil mist lubrication, mount bearings after cleaning and degreasing.

Procedures for mounting vary according to the fit requirements of the inner and outer rings.

Primarily, it is the inner ring of a machine tool bearing that rotates: thus, bearings with cylindrical bores are usually mounted by heating them to expand the inner ring (shrink fit). Bearings with tapered bores can be mounted directly onto a tapered shaft.

Outer rings are usually mounted with some clearance. The housing can be heated to make mounting easier. In cases where outer rings are to be mounted with interference fit, press fitting is feasible and may be combined with the housing heating method.

4. Inspection after Mounting

After bearings have been mounted, check shaft runout and the amount of preload. Descriptions of each process start on page 263 and page 264, respectively.

After checking, follow the operating inspection such as balancing of shaft and running-in process.

There are two kinds of shaft unbalance; "static unbalance" and "dynamic unbalance". The outline is explained on page 266.

Static unbalance of a shaft can be checked by lying the shaft horizontally on jigs which have smooth surface; when there is an uneven distribution of mass, the shaft rotates by its own weight with heavier phase down. Static unbalance can be improved by adding compensating mass to the rotor at a prescribed location.

It needs to rotate the shaft to check dynamic unbalance. Using the special instrument for, the dynamic unbalance can be measured. Improving of the unbalance can be done by adjusting the weight at both front and rear side of the shaft.

Running-in procedure is very important, especially for grease lubricated spindle. This process distributes grease over bearing free internal space uniformly and expel the excess grease. This procedure is explained on page 268.

Typical irregularities of operating spindle and the countermeasures for them are listed on page 275.

1. Cleaning the Bearings and Related Parts

1.1. Cleaning with kerosene

This section provides information on the cleaning process and proper handling of bearings during cleaning as well as devices used for cleaning.

1 Take the bearing out of its package.

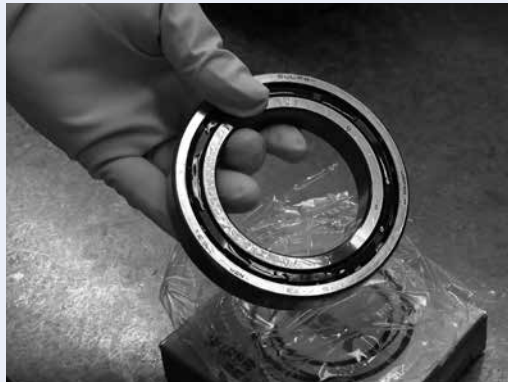

2 Without rotating it, pour cleaning oil over the bearing to remove anti-corrosion agent



3 Rotate the bearing while allowing cleaning oil to flow between the inner and outer ring, thereby removing anti-corrosion agent from the bearing interior. Make sure the bearing runs smoothly after cleaning.

4 Degrease by rinsing the bearing with clean organic solvent.

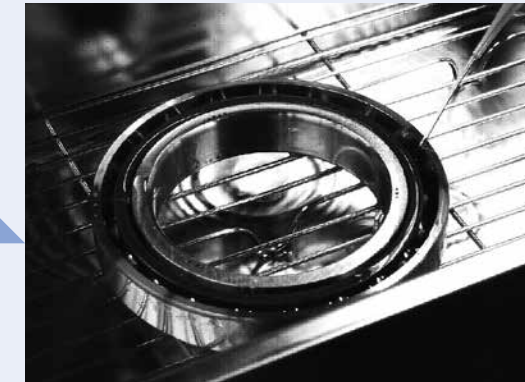

Cleaning process is finished

Handle bearings with care

The way you hold angular contact ball bearings is important: When holding the inner ring, make sure the bearing's outer ring back face is facing up. When holding the outer ring, make sure the bearing's outer ring front face is facing up.

When holding the inner ring

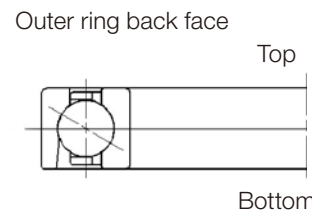

When holding the outer ring

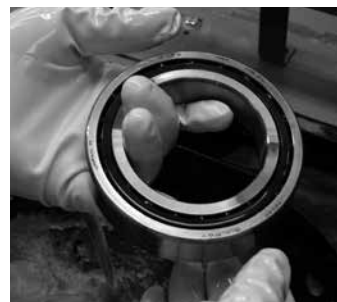
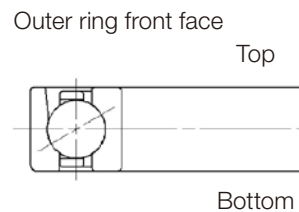

Cleaning device and cleaning oil

Always use a circulating filtration system to filter the cleaning fluid.

A pump is used to circulate the cleaning oil in the cleaning tank. The oil drain pipe is equipped with an oil filter that must be changed at regular intervals to prevent it becoming clogged.

Two-step filtration will efficiently remove larger and smaller particles and extend the service life of the filters.

Replace the cleaning oil at regular intervals.

Circulating filtration system (Example)

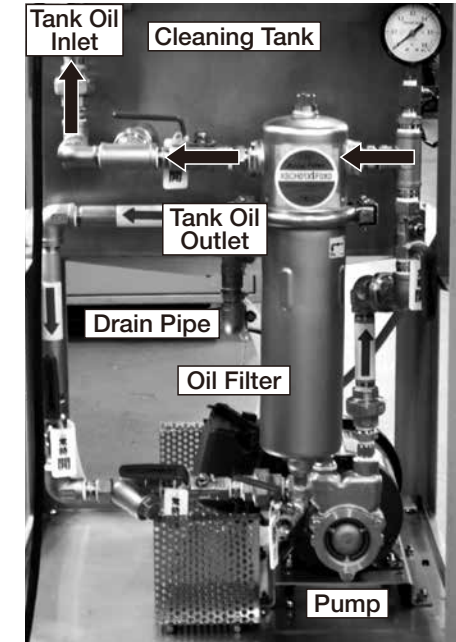
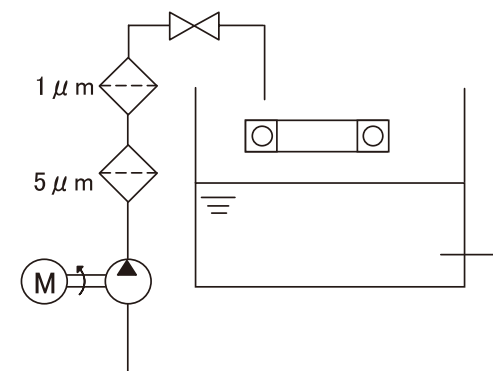

Note: Shown here is an example of a filtration system with one oil filter.

Degrease with caution

- (1) After using organic solvent for degreasing, do not re-use the waste fluid.
- (2) Do not rotate bearings during and after contact with degreasing solvent as it might cause damage to the raceways and balls.
- (3) Avoid the use of compressed air as particles suspended in the surrounding air may penetrate into the bearing interior.
- (4) For grease lubrication, pack bearings with grease after degreasing. For oil lubrication, apply clean lubrication oil to the bearing interior prior to mounting. Alternatively, coat the bearing by rinsing with lubricating oil diluted with degreasing solvent (oil plating method).

Necessary caution for handling kerosene and organic solvents

When working with kerosene and organic solvents, be aware of the hazards of fire and toxicity. Always take appropriate measures in line with applicable industrial safety laws and regulations to prevent accidents. Examples: Ground the cleaning devices to prevent sparks from static electricity; ensure adequate ventilation, etc.

As this section illustrates only the cleaning process as such, please understand NSK cannot assume any responsibility for risks associated with the handling of cleaning agents.

2. Checking the Dimensions of Related Parts

2.1 Gauging and adjusting tapered shafts

For precision cylindrical roller bearings to perform as expected, proper mounting onto a shaft and housing is essential.

If bearings are mounted with a mismatch between the taper angle of the bearing bore and the taper angle of the shaft, inner ring expansion will be uneven along the spindle axis, which will impede bearing performance during operation. This detrimental impact increases in the case of double-row cylindrical roller bearings due to their wider inner ring.

Fig 1.1 illustrates how uneven inner ring expansion during fitting caused by a mismatch of taper angle leads to a difference in radial clearance between the two rows. A large imbalance of load capacity ensues that results in lower rigidity; misaligned inner ring grooves result in irregular movement of the rollers, etc.

Even with single-row cylindrical roller bearings, misalignment of inner ring grooves causes unevenness of the contact points (running traces) of the rollers with the inner and outer ring, resulting in irregular roller motion.

Actual examples of such defects are discussed on page 272.

■ Taper angle

Please refer to pages 226-227 for taper angle values of cylindrical roller bearings with tapered bore.

■ Checking the shaft taper angle

We recommend you gauge the shaft taper with the bore taper of the actual bearing. Please follow these steps:

- Clean and degrease the tapered bore of the bearing and the tapered section of the shaft, then coat either of the tapers with blue dye very thinly and evenly.
- Push the bearing inner ring onto the shaft.
- Slightly rotate the inner ring, then withdraw the inner ring carefully from the shaft without rotating it (Fig. 1.2).
- Blue dye has rubbed off the tapered one onto another in places where both parts are in contact.
- The area of the tapered shaft that is dyed blue should cover at least 80% of the bearing width.

If the contact area is insufficient, modify the shaft taper accordingly.

Lead oxide may also be used instead of blue dye.

■ Types of taper contact

A uniform taper contact along the complete bearing bore surface, confirmed by the method described above, is an ideal fit that is hard to achieve because of limits to machining accuracy. In practice, differences of contact are likely to occur.

In Fig. 1.3, the shade of blue indicates the intensity of contact between bearing bore and shaft.

Contact at the large end of the shaft taper (a) means that contact is strongest in the area where the inner ring is thinnest. Therefore, row A will expand to a larger degree, and row B to a smaller degree. The result is a large imbalance of radial clearance, as shown in Fig. 1.1.

We recommend contact at the small end of the shaft taper (b) since the thick wall of the inner ring means row B is less likely to expand and the effect of taper irregularity can be absorbed more easily.

Fig. 1.1 Unevenness of Radial Clearance Due to Taper Mismatch

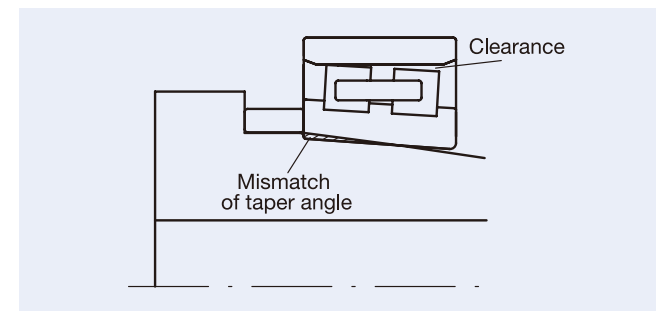

Fig. 1.2 Confirmation of Taper Angle with Coloured Paste

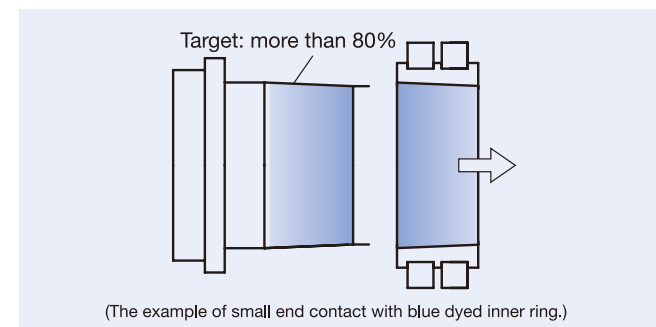
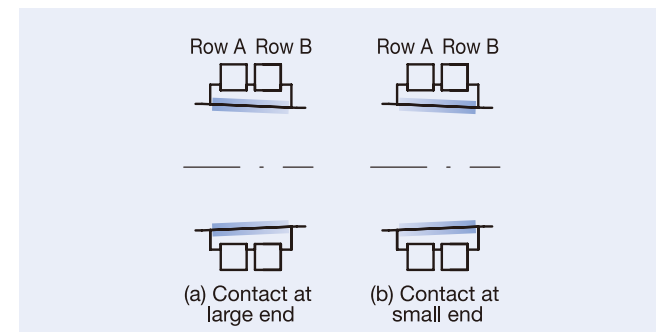

Fig. 1.3 Types of Taper Contact



2.2 Adjusting the radial clearance of cylindrical roller bearings

The internal radial clearance (preload) of cylindrical roller bearings is adjusted by pushing the inner ring up the tapered shaft, thereby expanding the inner ring. This process can be divided in four steps as explained below (Fig. 1.4).

Step 1: Push inner ring onto tapered shaft

Step 2: Measure radial clearance

Step 3: Measure the distance between inner ring and shaft shoulder

Step 4: Adjust spacer width as required to achieve target radial clearance

Step 1: Push inner ring onto tapered shaft

After cleaning and degreasing, slide the inner ring onto the shaft. Mount the inner ring by giving it a light impulse using a spacer (Fig. 1.5). Tighten the shaft locknut. For grease lubricated bearings, grease is not yet packed at this stage.

Please refer to pages 246-247 for details on the process of bearing cleaning.

Step 2: Measure radial clearance

Radial clearance is measured either (1) using a special instrument called a GN gauge or (2) without a GN gauge (calculation method). Descriptions of each measuring process start on page 250 and page 252, respectively.

Step 3: Measure the distance between inner ring and shaft shoulder

Using gauge blocks or feeler gauges etc., measure the distance L from the inner ring end face to the shaft shoulder (Fig. 1.6).

Take three or more measurements around the circumference and use the average in order to account for possible shaft misalignment during adjustment and for the accuracies of surrounding parts.

Step 4: Adjust spacer width as required to achieve target radial clearance

Based on the calculation of the width measured in step 3 and the other measurement values, determine the spacer width that will obtain the targeted radial clearance. Finish the spacer to this width.

Fig. 1.4 Adjusting the Radial Clearance of Cylindrical Roller Bearings

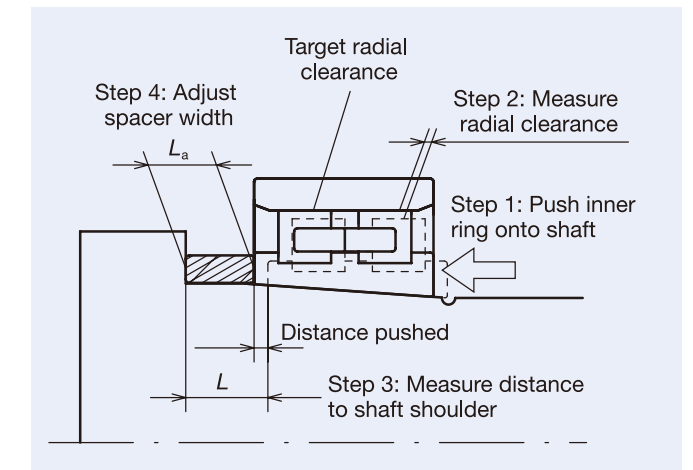

Fig. 1.5 Pushing the Inner Ring in Place

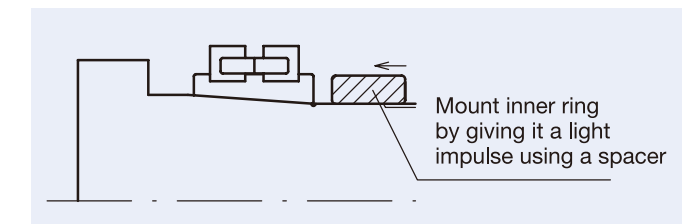
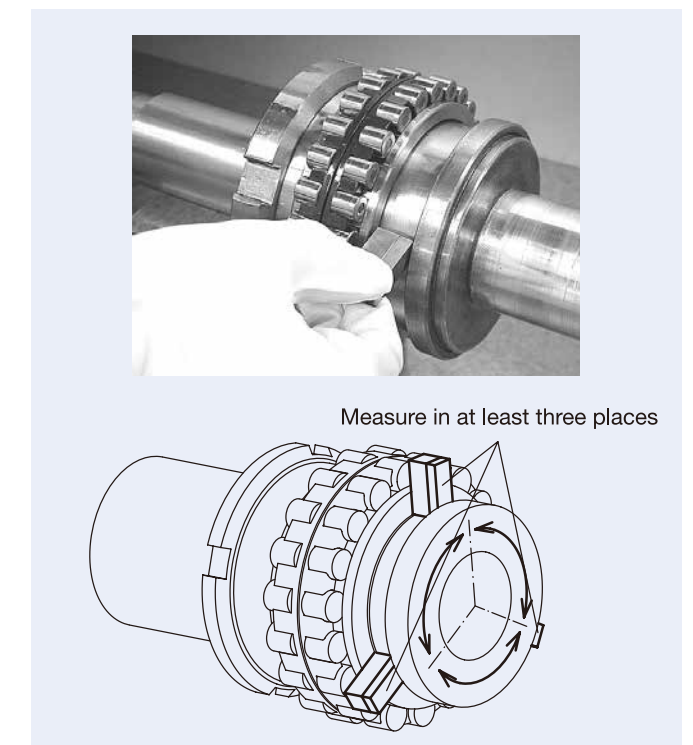

Fig. 1.6 Measuring the Required Spacer Width



(1) Measuring Radial Clearance of Cylindrical Roller Bearings (GN Gauge Method)

When mounting a cylindrical roller bearing with tapered bore onto a machine tool spindle, it is essential to accurately match the shaft taper with that of the bearing and to ensure that the desired radial internal clearance is attained after mounting. A GN gauge is a special instrument that allows precise measurement and control of mounted radial clearance during this process. GN gauges are especially effective when cylindrical roller bearings are used with radial preload.

Fig. 1.7 describes the components of GN gauges.

Fig. 1.7 Components of a GN Gauge

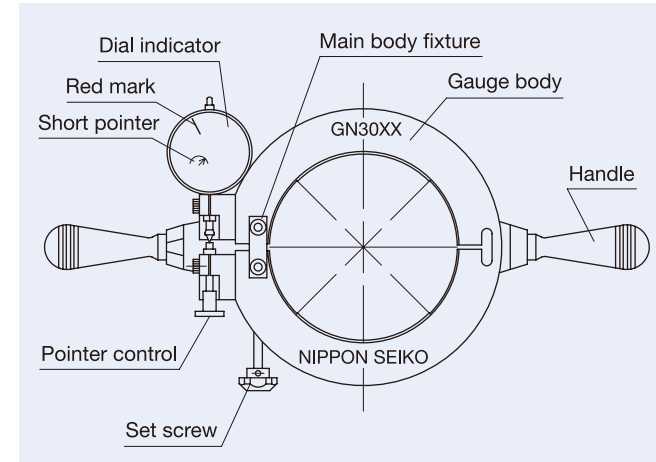

How to use a GN gauge

① Insert outer ring into housing

Recommended values for the fit between outer ring and housing are listed on page 233.

② Set cylinder gauge to zero

Ensure that the temperatures are the same for the outer ring (inserted into the housing), the inner ring, and the shaft. Then, measure the bore diameter of the outer ring at about four different locations using a cylinder gauge (dial bore gauge) and set the dial of the cylinder gauge to zero using the average value of the measurements (Fig. 1.8).

③ Adjust the bore diameter of the GN gauge

Loosen the bolt of the main body fixture on the GN gauge. Place the cylinder gauge in the bore of the GN gauge and adjust the setscrew until the dial on the cylinder gauge reads zero. The idea is to set the bore of the GN gauge to replicate that of the outer ring. Use the GN gauge in an upright position during this process to avoid inaccuracies in the cylindricity of the GN gauge bore due to its own weight (Fig. 1.9).

Fig. 1.8 Setting the Cylinder Gauge to Zero



Fig. 1.9 Adjusting the GN Gauge Bore

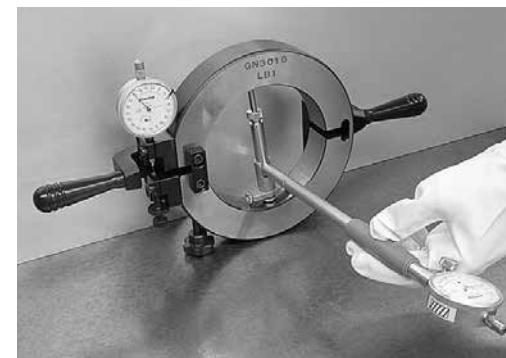

④ Correct the GN gauge

Next, use the pointer control on the dial indicator to adjust the main pointer to the red mark for gauge correction, as shown in Fig. 1.10. Confirm that the short pointer is close to 2 on the secondary dial.

Gauge correction compensates for the elastic deformation of the rollers caused by the measuring pressure of the GN gauge. The amount of correction is different for each GN gauge. It is determined when the gauge is shipped.

⑤ Set the GN gauge

Expand the GN gauge by adjusting the setscrew. Place centrally over the inner ring rollers (Fig 1.11) and release the setscrew to allow the GN gauge to spring closed over the rollers (so that contact deformation is applied to the rollers by the elasticity of the GN gauge only).

⑥ Read the dial

Read the main pointer on the dial indicator. The geometrical structure of the GN gauge (Fig 1.12) is such that a given deviation from zero in measuring point A produces twice that amount on the dial. The actual amount of clearance or preload is $\frac{1}{2}$ the reading.

Examples:

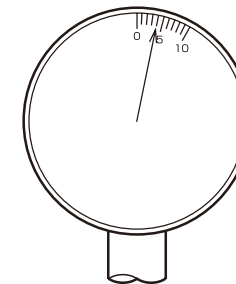

Example 1:
A reading of 4 (clockwise) indicates a radial clearance of $+2\mu\text{m}$

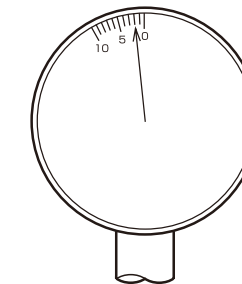

Example 2:
A reading of 2 (anti-clockwise) indicates a radial clearance of $-1\mu\text{m}$

⑦ Readjust the amount the inner ring is pushed up the shaft

As in ⑤, widen the GN gauge by turning the set screw until the dial shows play. Take the GN gauge off the inner ring. Tighten the shaft locknut. Then measure radial clearance again. Repeat these steps until the GN gauge indicates the target clearance value.

⑧ Measure the required spacer width

Take measurement of the distance between the inner ring end face and the shaft shoulder as described on page 249, step 3.

⑨ Adjust the spacer width

Finish the spacer width to the dimension obtained in ⑧.

Fig. 1.10 Correcting the GN Gauge



Fig. 1.11 Setting the GN Gauge

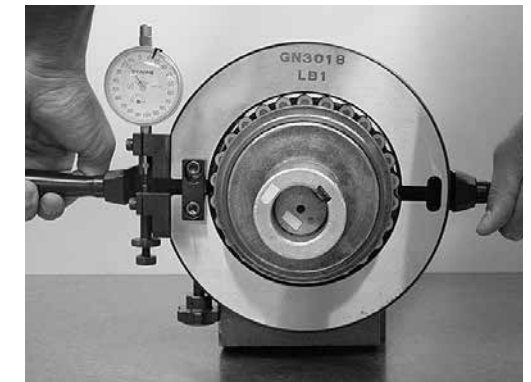
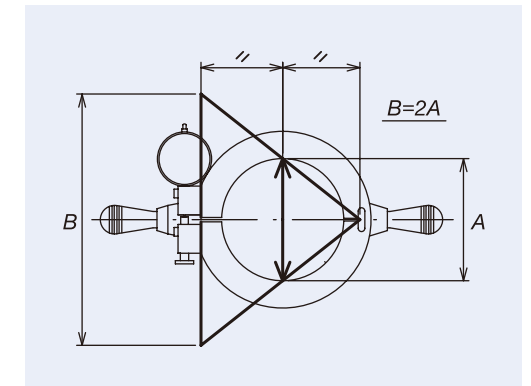

Fig. 1.11 Geometrical Structure of the GN Gauge



(2) Adjusting Radial Clearance of Cylindrical Roller Bearings Without a GN Gauge (Calculation Method)

This section briefly explains how to measure radial clearance without using a GN gauge and how to calculate the spacer width L_a required to obtain the target mounted clearance value.

When not using a GN gauge, the outer ring needs to be measured before inserting it into the housing. Further, the amount of shrinkage of the outer ring raceway diameter due to fitting in the housing must be taken into account when determining the required dimension of the spacer for clearance adjustment.

$$L_a = L - K (\Delta r_m - \Delta r + \Delta r_e)$$

- Based upon measurement of the housing bore and the dimension of the bearing outer ring, calculate the amount of shrinkage of the outer ring raceway diameter owing to the fit of the outer ring with the housing, Δr_e . If the outer ring is mounted with positive clearance, there is no need for this calculation (in this case, $\Delta r_e = 0$) (Fig. 1.13).

$$\Delta r_e = (D_h - D) \times H$$

(if this value is positive, a value of $\Delta r_e = 0$ is adopted)

Table 1.1 Housing Wall Thickness and Shrinkage Factor H

Housing wall thickness ratio $h_o (=D_o/D_h)$	Shrinkage factor H
110%	0.32
120%	0.47
130%	0.56
140%	0.61
150%	0.65
160%	0.68
170%	0.70
180%	0.71

- Place the outer ring over the rollers. Apply a dial gauge to the outside diameter of the outer ring. Then lightly tighten the shaft locknut (Fig. 1.14 above).

- Moving the outer ring up and down by hand, measure the free radial play Δr_m with the dial gauge.

Body temperature may increase the temperature of the outer ring, resulting in an erroneous measurement. Therefore we recommend you wear gloves and finish the measurement quickly (Fig. 1.14 below).

Fig 1.13 Explanation of Variables

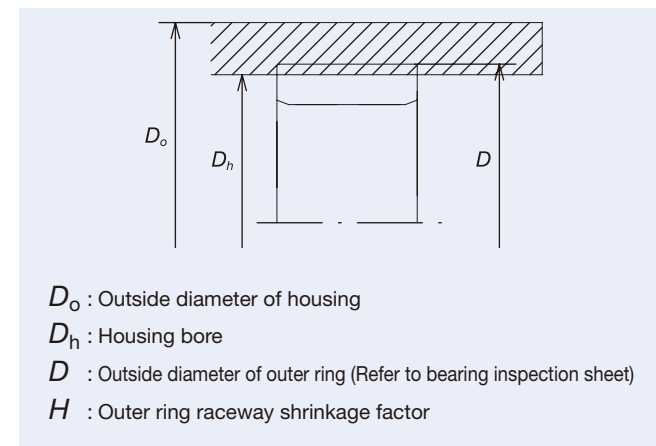
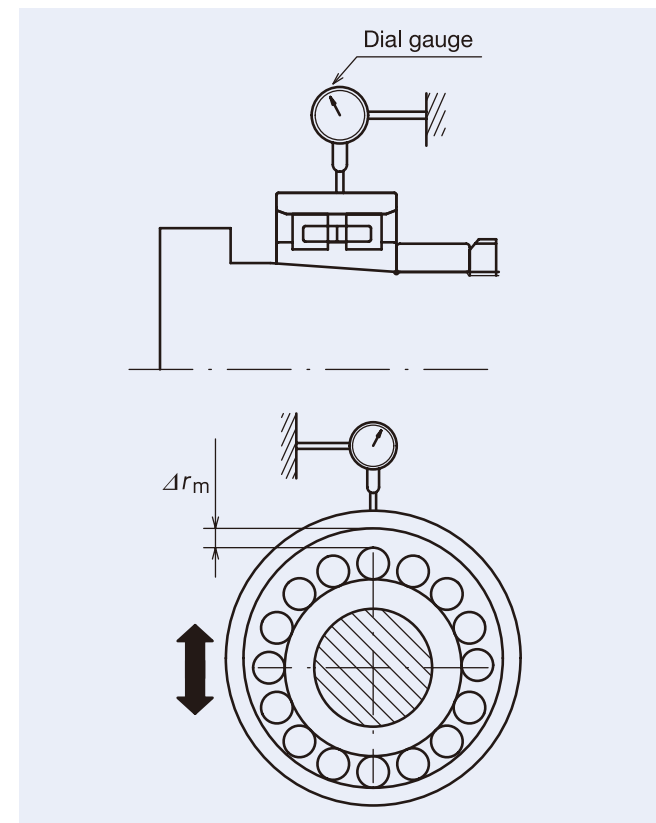

Fig 1.14 Measuring the Free Radial Play of the Outer Ring



- Repeat ② and ③ until $\Delta r_m = 5\mu\text{m}$

Note: We adopted $5\mu\text{m}$ as a guideline value because if the free radial play Δr_m is too large the deformation of the outer ring due to the measuring force may result in an incorrect measurement. Smaller values than $5\mu\text{m}$ are acceptable, for example if the target radial clearance Δr is negative. However, it should be considered that the radial clearance will be further reduced due to shrinkage of the outer ring by Δr_e as determined in ①, so the shaft locknut should not be tightened excessively (Fig. 1.15).

- Measure the distance between the inner ring end face and the shaft shoulder L as described on page 249, step 3.

- Using the following equations, determine the inner ring expansion Δr_i required to achieve the target radial clearance Δr as well as the necessary distance ΔL_i that the inner ring needs to be pushed to achieve expansion Δr_i (Fig. 1.16).

$$\Delta r_i = \Delta r_m + \Delta r_e - \Delta r$$

$$\Delta L_i = K \Delta r_i$$

Table 1.2 Hollow Shaft Ratio k_o and Coefficient K

Hollow shaft ratio $k_o (=d_o/d)$	Coefficient K	Hollow shaft ratio $k_o (=d_o/d)$	Coefficient K
0%	14.1	50%	15.2
10%	14.1	60%	16.0
20%	14.2	70%	17.4
30%	14.4	80%	20.2
40%	14.7		

- Calculate the required length L_a for the clearance adjustment spacer according to the results obtained in ⑤ and ⑥:

$$L_a = L - \Delta L_i$$

(Example calculation)

Setting radial clearance after mounting to $\Delta r = -0.002\text{ mm}$ for NN3020MBKR:

$$h_o = D_o/D = 225/150 = 150\% \Rightarrow H = 0.65$$

Shrinkage of outer ring raceway diameter due to fitting

$$\Delta r_e = (149.993 - 149.998) \times 0.65 = -0.003\text{ mm}$$

Amount of inner ring expansion necessary to achieve target clearance value

$$\Delta r_i = 0.005 - 0.003 - (-0.002) = 0.004\text{ mm}$$

$$k_o = d_o/d = 50/100 = 50\% \Rightarrow K = 15.2$$

Distance that the inner ring needs to be pushed up the tapered shaft

$$\Delta L_i = 15.2 \times 0.004 = 0.061\text{ mm}$$

Width of clearance adjustment spacer

$$L_a = 20.55 - 0.061 = 20.489\text{ mm}$$

Values used in the calculation example (mm)

Δr	-0.002
Δr_m	0.005
D_o	225
D	149.998
D_h	149.993
d	100
d_o	50
L	20.55

Fig 1.15 Deformation of the Outer Ring Due to Measuring Force

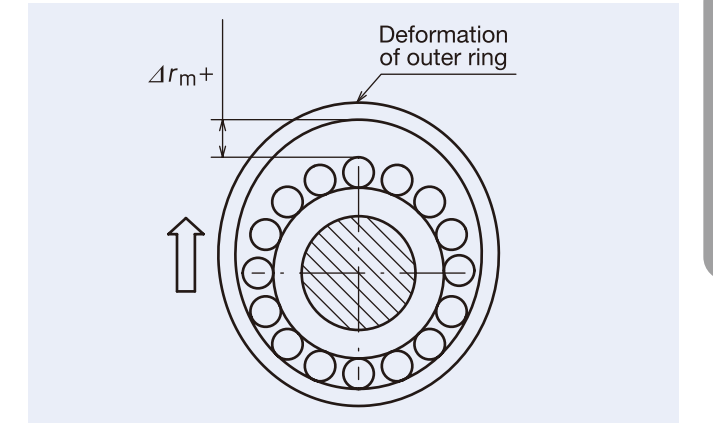
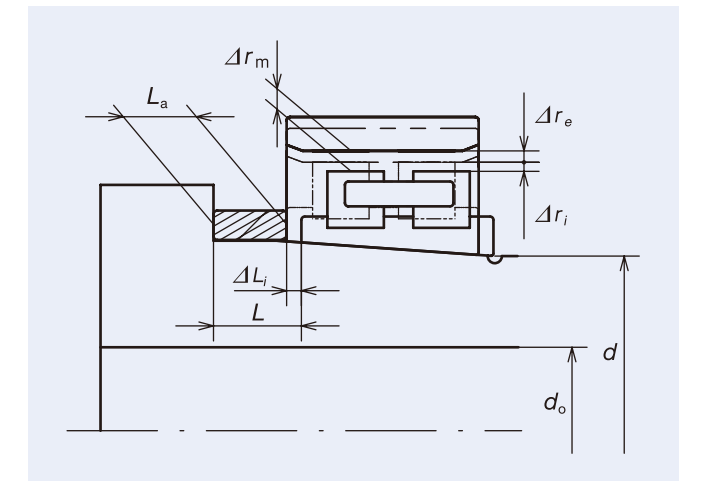

Fig 1.16 Explanation of Variables



2.2 Securing the Outer Ring

A retaining cover held by bolts is generally used to secure the bearing outer ring axially. If a bolt is tightened excessively or a combination of bolts is tightened unevenly, the bearing outer ring may become deformed. Therefore the dimensions of the surrounding parts should be checked and the clearance between retaining cover and housing controlled prior to mounting the bearings into the housing.

Measure the bearing width as well as the width of the housing section where the bearing seats are and the amount the retaining cover projects (stick-out); if necessary, machine the retaining cover to adjust the clearance between the retaining cover and housing (Fig. 1.17). In the case of a DB arrangement, we recommend to adjust the clearance between the retaining cover and housing end face at this point to about 0.01 to 0.05 mm according to the bearing size as listed in Table 1.5 on page 261 before the bolts are completely tightened.

Figures 1.18 through 1.20 show examples of deformation of the outer ring raceway caused by securing the outer ring.

Fig. 1.18: Clearance between retaining cover and housing and outer ring raceway deformation of a small bearing

Fig. 1.19: Example of deformation of the outer ring of an angular contact ball bearing as a result of

tightening force of the retaining cover

Fig. 1.20: Deformation of the outer ring of a double-row cylindrical roller bearing as a result of tightening force of the retaining cover

Fig. 1.17 Adjusting the Retaining Cover

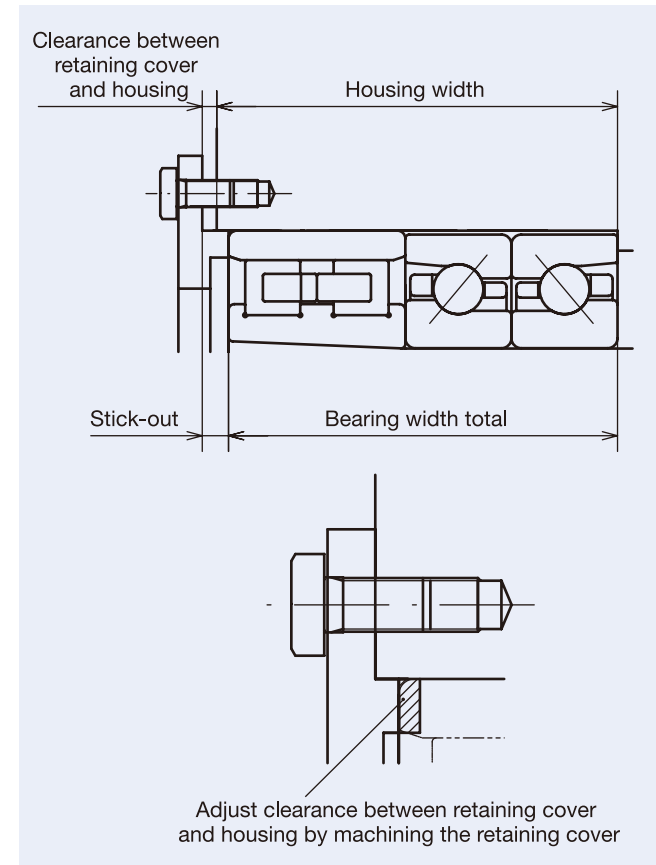
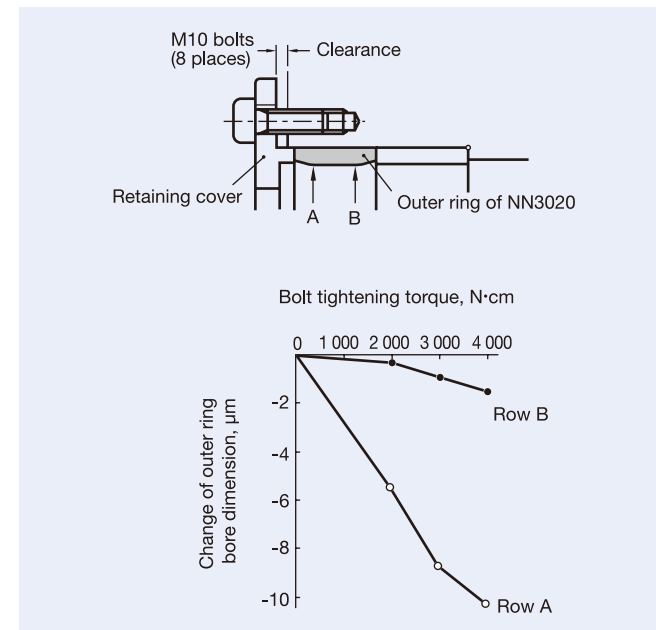

Fig. 1.20 Example of Outer Ring Deformation of a Double-Row Cylindrical Roller Bearing Caused by Tightening Force of Retaining Cover



Note concerning the adjustment of clearance between the retaining cover and housing in DF arrangements

When using bearings in DF arrangement (including DFD, DFF, DFT arrangements etc.), there is axial clearance on the outer rings before the outer rings are secured. Therefore, the outer ring width total cannot simply be measured as such. Some methods of working out the exact outer ring width total are:

- ① Measure the outer ring width of each bearing individually.
- ② Rearrange bearings so that there is no axial clearance: e.g. DT, DTT etc.
- ③ Measure the outer ring width of your bearing arrangement, then correct for the amount of axial clearance.

Fig. 1.21 Influence of Arrangement Type on Measurement of Outer Ring Width Total

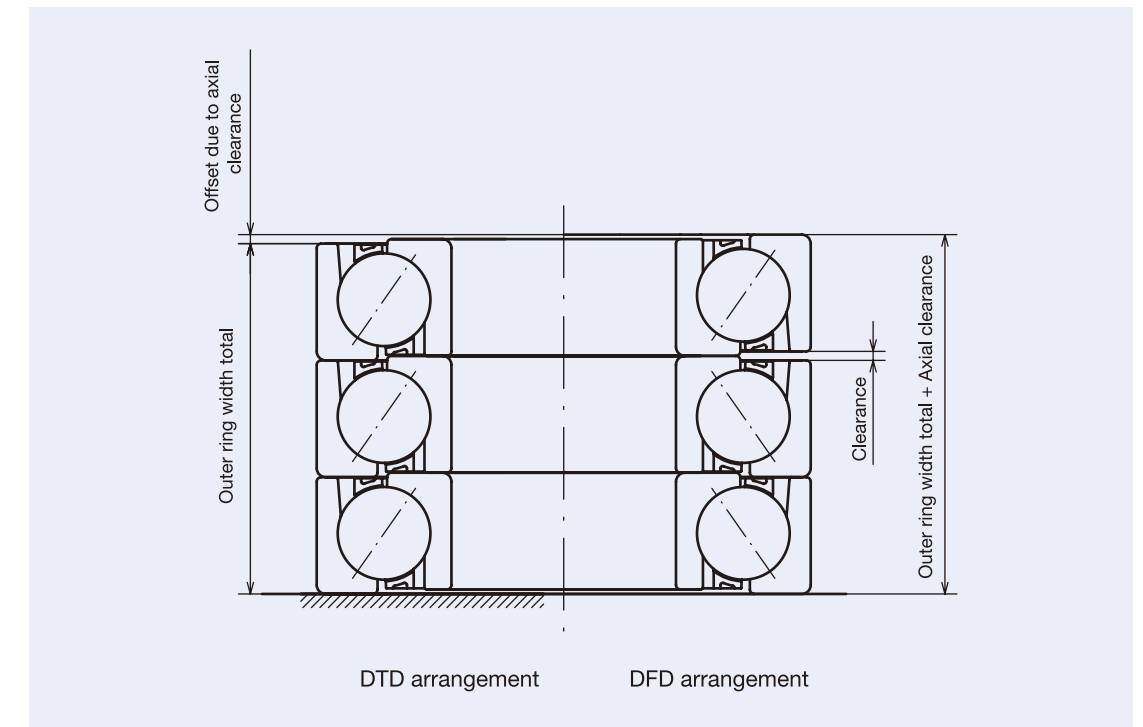

Note for method ①: When using universal arrangement bearings the outer ring width of each bearing is printed on the bearing inspection sheet, so there is no need for you to measure again.

Note for method ②: After rearranging the bearings for measurement, take care when mounting not to mistake the order and direction of bearings.

Note for method ③: In the case of matched bearings, axial clearance is stated on the bearing inspection sheet, so you only need to subtract this value after you have measured the outer ring width of your arrangement.

Fig. 1.18 Example of Outer Ring Deformation Due to Clearance Between Retaining Cover and Housing

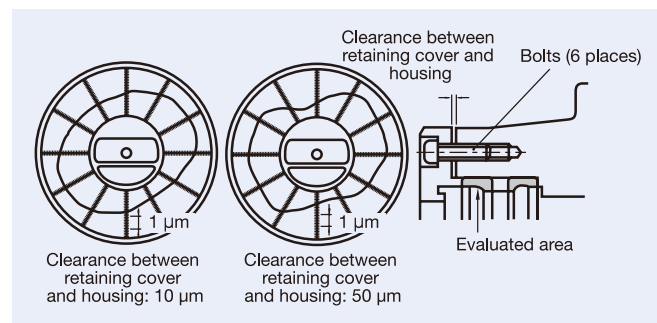
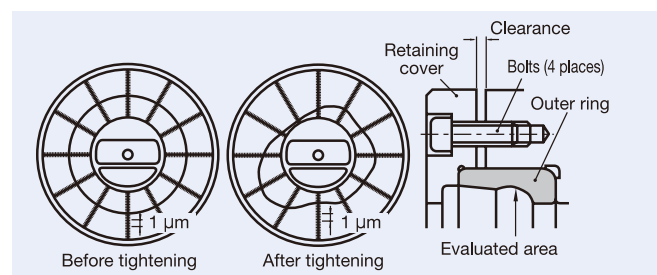

Fig. 1.19 Example of Outer Ring Deformation Caused by Tightening of Retaining Cover



3.1 Packing grease

Procedure for packing grease after cleaning bearings

After selecting a grease suited to the operating conditions, it needs to be properly packed into the bearing. Packing bearings incorrectly or with too much grease may result in a much longer running-in period or cause unusual temperature rise leading to seizure. Following proper procedures for packing grease and using the correct amount of grease require careful attention. Recommended procedures are as follows:

1. Pre-Inspection

Check to ensure there is no foreign matter in the bearing interior. Bearings for high-speed spindles should be cleaned and degreased before packing with grease. For other applications, it is advisable to remove the anti-corrosion agent adhering to interior surfaces of the bearings to prevent grease outflow.

2. Grease dispensers

Use a grease dispenser, such as a plastic syringe for precision grease dispensing. If possible, use a dispenser that comes with a gauge for packing accurate amounts of grease. Alternatively, measure the weight of the bearing before and after packing.

3. Amount of grease

Recommended amounts of grease for super precision bearings:

Angular contact ball bearings for high-speed spindles:

15-30% of internal space

Cylindrical roller bearings for high-speed spindles:

10-15% of internal space

Increasing the amount of grease extends grease life. However, more time will be required for running-in and the bearing will exhibit higher temperature rise. The advantages and disadvantages need to be considered and the grease amount chosen to suit operating conditions.

For small bearings up to 30 mm bore diameter, setting the grease amount to 15% of internal space results in a very small total amount of grease. In such cases, we suggest 20% for increased reliability.

Recommended grease quantities for each bearing type are listed in Table 1.3.

Packing method for ball bearings

- (1) Pack grease evenly between the balls. If a ring guided cage is used, apply a light coating of grease on the guided surface of the cage.
- (2) Rotate the bearing by hand to spread the grease evenly. In doing so, take care not to expose angular contact ball bearings to reverse thrust loads.

Packing method for cylindrical roller bearings

- (1) Coat about 80% of the grease amount evenly on the rolling surfaces of the rollers. Avoid putting too much grease on the cage bore. Grease on the cage bore is difficult to disperse during the running-in period, which can result in a rapid rise in temperature or a long running-in period.
- (2) Spread the grease applied to the rolling surfaces thinly to the roller end faces, roller cage contact points and along the face edges of each cage pocket.
- (3) Using the remaining 20% of grease, apply a thin film of grease to the raceway surface of the mounted outer ring (to the raceway surface of the inner ring for NNU type bearings).

Fig. 1.22 Grease Packed Angular Contact Ball Bearing



Fig. 1.23 Grease Packed Cylindrical Roller Bearing



Table 1.3 Recommended Grease Quantities for High-Speed Spindle Bearings

Unit: g/bearing

Bore number	Nominal bearing bore dia. (mm)	Angular contact ball bearings: 15% of free internal space						Cylindrical roller bearings: 10% of free internal space			
		79 Series BNR19 BER19 BSR19	70 Series BNRD10 BERD10	72 Series	BSR10 BNR10 BER10 BAR10 BTR10	TAC29F TAC29D	TAC20F TAC20D	NN49 Series NNU49 series	NN39 Series	NN30 Series	N10 Series
5	5	—	—	0.02	—	—	—	—	—	—	—
6	6	—	0.04	0.07	0.03	—	—	—	—	—	—
7	7	—	0.07	—	0.04	—	—	—	—	—	—
8	8	—	0.11	0.09	0.09	—	—	—	—	—	—
00	10	0.05	0.12	0.14	0.10	—	—	—	—	—	—
01	12	0.06	0.13	0.22	0.11	—	—	—	—	—	—
02	15	0.11	0.17	0.27	0.17	—	—	—	—	—	—
03	17	0.12	0.22	0.38	0.22	—	—	—	—	—	—
04	20	0.21	0.41	0.63	0.41	—	—	—	—	—	—
05	25	0.25	0.48	0.79	0.50	—	—	—	—	0.3	—
06	30	0.29	0.64	1.2	0.53	—	—	—	—	0.6	0.4
07	35	0.44	0.91	1.6	0.72	—	—	—	—	0.7	0.5
08	40	0.70	1.1	2.0	0.85	—	—	—	—	0.9	0.6
09	45	0.77	1.4	2.5	1.1	—	—	—	—	1.2	0.9
10	50	0.84	1.5	2.8	1.1	—	1.6	—	—	1.3	1.0
11	55	1.1	2.2	3.7	1.6	—	2.2	—	—	1.8	1.3
12	60	1.1	2.4	4.5	1.7	—	2.3	—	—	2.0	1.4
13	65	1.2	2.5	5.3	1.8	—	2.5	—	—	2.0	1.5
14	70	2.0	3.4	6.0	2.6	—	3.7	—	—	3.0	2.2
15	75	2.1	3.4	6.5	2.7	—	3.9	—	—	3.3	2.4
16	80	2.3	4.7	8.1	3.6	—	4.9	—	—	4.4	3.3
17	85	3.3	4.9	10	3.8	—	5.1	—	—	4.5	3.4
18	90	3.4	6.2	12	5.1	—	7.1	—	—	6.0	4.2
19	95	3.3	6.4	15	5.3	—	7.4	—	—	6.2	4.3
20	100	4.6	6.7	18	5.7	4.9	7.7	5.0	4.2	6.3	4.5
21	105	4.8	8.4	21	7.1	—	9.3	5.2	—	8.7	5.4
22	110	4.9	11	25	8.5	5.3	11	5.4	4.4	10	6.9
24	120	7.3	11	29	9.1	7.0	12	7.8	6.1	12	7.8
26	130	8.4	17	32	14	8.9	18	11	7.9	17	12
28	140	9.2	19	39	16	—	41	11	8.7	18	13
30	150	13	23	49	20	30	51	18	13	22	15
32	160	16	29	—	25	34	62	18	14	27	20
34	170	16	40	—	30	36	79	19	14	35	25
36	180	24	49	—	42	50	108	26	22	48	33
38	190	26	50	—	47	47	118	28	22	50	35
40	200	35	66	—	57	74	145	41	32	65	43
44	220	39	87	—	66	77	184	45	35	88	59
48	240	41	96	—	71	89	199	48	38	92	63
52	260	72	142	—	103	147	278	82	65	130	94
56	280	75	151	—	—	158	—	89	69	146	100

· To convert to volume value, divide the value listed above by 0.93 (density 0.93g/cc) for the greases listed on Page 219.

· Values listed for angular contact ball bearings are for filling 15% of the free internal space (X fill). If filling 20% (K fill), multiply values by 1.3 and if filling 30% (L fill), multiply by 2.

· Please refer to page 146 and 148 for the recommended grease quantities for angular contact thrust ball bearings for ball screw support.

· For bore diameters larger than 280mm, please contact NSK.

3.2 Mounting of Bearings with Cylindrical Bores

(1) Press Fit

Press fits tend to be used for smaller bearings. A mounting tool is placed on the inner ring as shown in Fig. 1.24 and the bearing is slowly pressed on the shaft with a press until the side of the inner ring rests against the shoulder of the shaft. When press mounting the inner ring, the mounting tool must never be placed on the outer ring, as it would cause dents or other damage to the raceway surfaces.

Before mounting, lightly greasing or oiling the mating parts is recommended for smooth insertion. Never use a hammer when mounting super precision bearings.

In the case of separable bearings, such as cylindrical roller bearings and tapered roller bearings, the inner and outer rings can be mounted onto the shaft and into the housing as separate units. When assembling the two units, take extra care to align the inner and outer rings correctly. Careless or forced assembly may cause scratches on the rolling contact surfaces.

(2) Shrink Fit

Press fitting large bearings or press fitting bearings with high interference requires a great deal of force. Therefore, a shrink fit is widely used. The inner rings of the bearings are heated to expand them before mounting. This method prevents excessive force from being imposed on the bearings and enables mounting them in a short time.

The temperature required for shrink fitting depends on the bearing bore size and the selected interference. To aid you in selecting the right temperature, Fig. 1.25 shows the expansion of the inner ring for various temperature differences and bearing sizes.

The following precautions need to be taken when shrink fitting:

1. Do not heat bearings to more than 120 °C.
2. Heat the bearings to a temperature 20 to 30 °C higher than the lowest temperature required for mounting without interference since the inner ring will cool a little during mounting.
3. After mounting, the bearings will shrink in the axial direction as well as the radial direction while cooling. Therefore, after confirming that the bearing has sufficiently cooled down, it is advisable to press by applying the mounting tool again or by further tightening the locknut, to eliminate any clearance between the bearing and shoulder (Fig 1.26).

Using NSK Bearing Heaters makes the shrink fit process more efficient. For more information, refer to Pages 182-183

Fig 1.27 Heating the Inner Ring by means of a Hot Plate

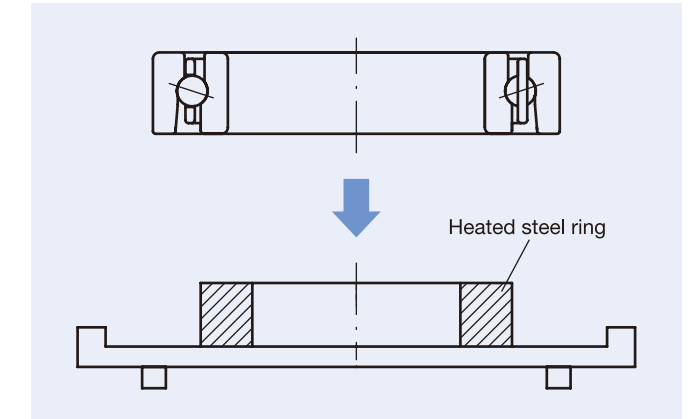

Fig 1.26 Additional Pressing

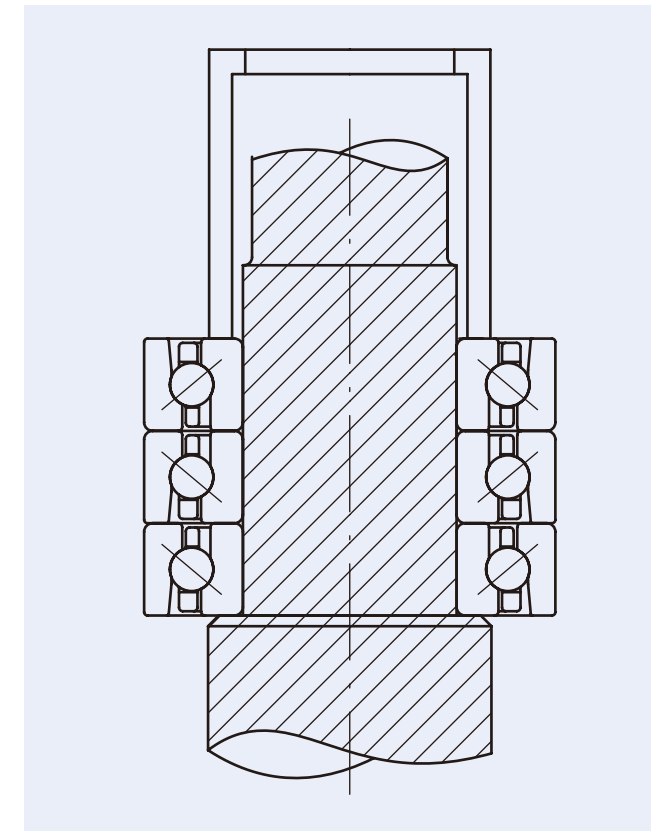

Fig 1.24 Press Fitting the Inner Ring

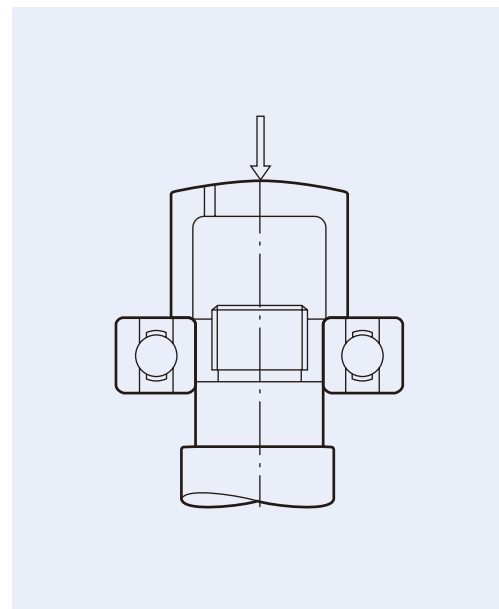
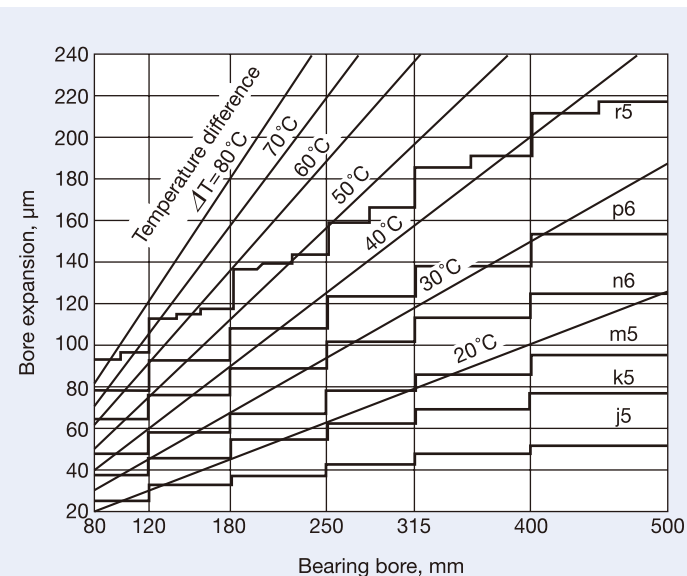

Fig 1.25 Temperature and Thermal Expansion of Inner Ring



3.3 Securing the Bearing

(1) Securing the inner ring

The inner ring is usually secured onto the shaft by tightening the locknut on the threaded shaft, which explains why perpendicularity of the threads and the end face of the locknut are very important. Even if accuracy as a single component is good, a gap between the shaft and locknut can result in a slightly tilted locknut, causing shaft misalignment, which in turn results in misalignment of the bearing. Therefore, adjustments are necessary to ensure constant running accuracy. It is important that the locknut is completely tightened so as to eliminate any risk of it becoming loose.

Tightening torque information for shaft locknuts is shown in Table 1.5.

To reduce the risk of unbalance due to locknut misalignment and clearance between the shaft thread and locknut thread, stepped sleeves are widely used to achieve an interference fit between the shaft and the sleeve bore. However, compared to a locknut a stepped sleeve is more likely to become loose after continuous operation, so it must be checked periodically.

When a wide spacer is used between combined bearings with position preload, and the tightening torque of the locknut is excessive, the inner ring spacer may become deformed and alter the preload increased to a level higher than expected. It is necessary to consider this deformation when determining the preload.

Bearings for machine tool spindles

Refer to Table 1.5 for recommended tightening force values.

Please note that when shaft interference increases, insertion pressure increases. Add an allowance to the insertion pressure value to obtain the tightening force.

Extra caution is required for high-speed operation, in particular.

Angular contact thrust ball bearings for ball screw support

Recommended locknut tightening force values for face-to-face combination (DF, DFD, DFT, etc.) are listed in Table 1.5.

For back-to-back combination (DB, DBD, DBT etc.), we recommend adding preload to the tightening force value from Table 1.5 to obtain the recommended locknut tightening force. However, compare the value thus obtained to the insertion pressure. If the insertion pressure value is higher, use the insertion pressure value and add an allowance to obtain the locknut tightening force.

(2) Securing the outer ring

Adjust the clearance between the retaining cover and housing as shown in Table 1.5, then tighten the bolts. Take care when tightening the bolts since uneven tightening forces will increase out-of-roundness of the outer ring.

Reference tightening torque values for each bolt size are listed in Table 1.4.

Table 1.4 Bolt Tightening Torque for Securing the Outer Ring

Nominal thread dimension	Tightening torque N·m
M3×0.5	1.7
M4×0.7	3.9
M5×0.8	7.9
M6×1	13.5
M8×1.25	32.8
M10×1.5	65.0
M12×1.75	114
M14×2	180
M16×2	281
M18×2.5	387
M20×2.5	549
M22×2.5	747
M24×3	949

Note: Tightening torque is affected by various conditions such as material and surface conditions. Therefore, the values in this table are reference values only.

Table 1.5 Shaft Locknut Tightening Force and Clearance Between Retaining Cover and Housing

Nominal bearing bore (mm)	Locknut tightening force (N)	Locknut tightening torque, reference (N·m)	Clearance between retaining cover and housing (mm)
6	1 500	2	0.01 ~ 0.03
8	1 500	2	0.01 ~ 0.03
10	1 500	3	0.01 ~ 0.03
12	3 000	7	0.01 ~ 0.03
15	3 000	8	0.01 ~ 0.03
17	3 000	9	0.01 ~ 0.03
20	4 900	17	0.01 ~ 0.03
25	4 900	21	0.01 ~ 0.03
30	4 900	25	0.01 ~ 0.03
35	9 800	57	0.01 ~ 0.03
40	9 800	64	0.01 ~ 0.03
45	9 800	72	0.01 ~ 0.03
50	9 800	80	0.01 ~ 0.03
55	14 700	132	0.01 ~ 0.03
60	14 700	142	0.01 ~ 0.03
65	14 700	153	0.01 ~ 0.03
70	14 700	166	0.01 ~ 0.03
75	14 700	176	0.01 ~ 0.03
80	19 600	251	0.01 ~ 0.03
85	19 600	267	0.01 ~ 0.03
90	19 600	281	0.01 ~ 0.03
95	19 600	296	0.01 ~ 0.03
100	19 600	311	0.01 ~ 0.03
105	19 600	327	0.01 ~ 0.03
110	19 600	343	0.01 ~ 0.03
120	19 600	371	0.01 ~ 0.03
130	19 600	403	0.01 ~ 0.03
140	29 400	649	0.03 ~ 0.05
150	29 400	695	0.03 ~ 0.05
160	29 400	745	0.03 ~ 0.05
170	29 400	796	0.03 ~ 0.05
180	29 400	841	0.03 ~ 0.05
190	29 400	886	0.03 ~ 0.05
200	29 400	932	0.03 ~ 0.05
220	39 200	—	0.03 ~ 0.05
240	39 200	—	0.03 ~ 0.05
260	39 200	—	0.03 ~ 0.05
280	39 200	—	0.03 ~ 0.05
300	39 200	—	0.03 ~ 0.05

Note: For bearing bores larger than 300 mm, please contact NSK.

Conversion equation of locknut tightening torque

$$T = 0.5F \{d_p \cdot \tan(\rho^* + \beta) + d_w \cdot \mu_w\} \times 10^{-3} \quad [\text{N}\cdot\text{m}]$$

The locknut tightening torque values in the table have been calculated using a friction coefficient of 0.15.

- T : Locknut tightening torque [N·m]
- F : Locknut tightening force [N]
- d_p : Effective diameter of locknut [mm]
- ρ^* : Friction angle of locknut surface
 $\rho^* = \tan^{-1} \mu_S$
- μ_S : Friction coefficient of locknut surface
- d_w : Frictional torque equivalent diameter at locknut seating surface [mm]
- μ_w : Friction coefficient of locknut seating surface
- β : Lead angle of nut
 $\beta = \tan^{-1}(\text{pitch}/(3.142 d_p))$

Equation of press-fit force (insertion pressure)

$$K = \mu \cdot p_m \cdot \pi \cdot d \cdot B \quad [\text{N}]$$

$$p_m = \frac{E}{2} \frac{\Delta d}{d} \frac{(1 - k^2)(1 - k_0^2)}{1 - k^2 k_0^2}$$

- μ : Friction coefficient at fitting surface [=0.12]
- p_m : Surface pressure [MPa]
- d : Shaft diameter [mm]
- B : Bearing width [mm]
- Δd : Effective interference [mm]
- E : Young's modulus of steel [MPa]
- k : Wall thickness ratio of inner ring ($k = d/D_i$)
- D_i : Raceway diameter of inner ring [mm]
- k_0 : Wall thickness ratio of hollow shaft ($k_0 = d_0/d$)
- d_0 : Bore diameter of hollow shaft [mm]

3.4 Precautions for Mounting Angular Contact Ball Bearings

Due to design restrictions, an angular contact ball bearing can sustain loads in only one direction. Therefore, when mounting angular contact ball bearings onto the shaft or into the housing, it is important not to apply any load in the wrong direction.

Pay special attention to the mounting order of combined bearings, as it is different for back-to-back and face-to-face arrangements.

Fig 1.28 Direction of Load for Angular Contact Ball Bearings

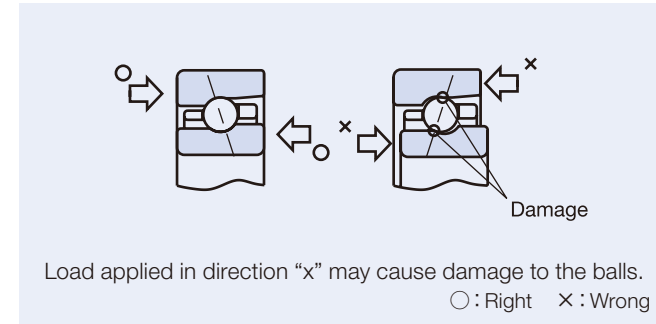

Fig 1.29 Mounting of Back-to-back Arrangement

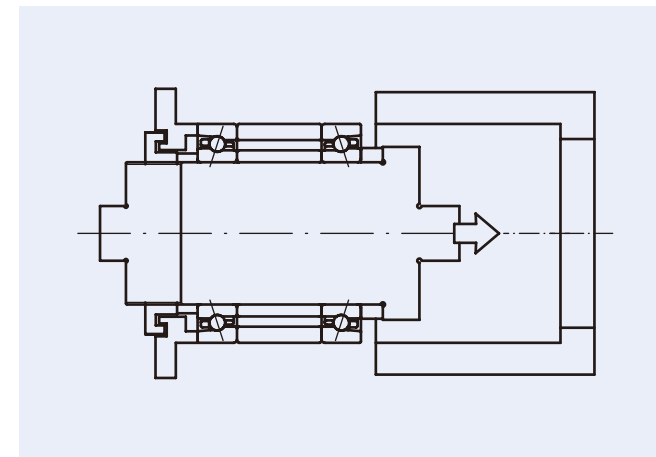
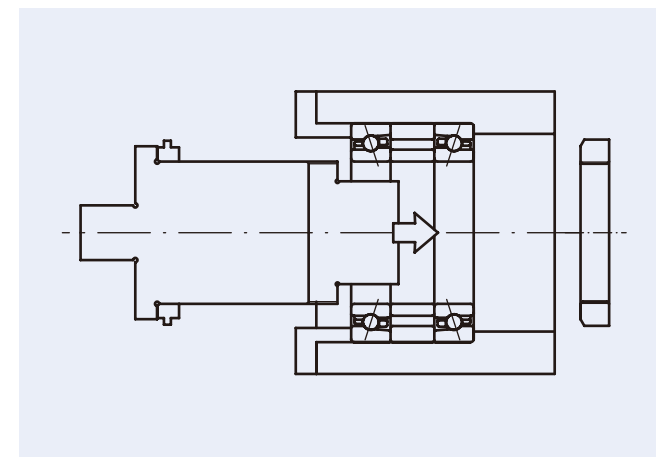

Fig 1.30 Mounting of Face-to-face Arrangement



Back-to-back arrangement:

- ① Press bearings onto shaft.
- ② Tighten shaft locknut for preloading.
- ③ Insert shaft with bearings into the housing and attach the retaining cover.

Face-to-face arrangement:

- ① Insert bearings into housing.
- ② Secure the retaining cover for preloading.
- ③ Insert shaft into the inner rings and tighten the shaft locknut.

Reverse the order of each step for dismounting.

4. Inspection after Mounting

4.1 Runout Accuracy

Spindle accuracy requires accurate components as well as an accurate assembly process. For example, misalignment of the locknut can cause the shaft and bearing to bend when tightened, as depicted in Fig. 1.31.

- 1: Assembled bearing outer ring face runout with raceway for angular contact ball bearings:
Adjust to 0.002 mm or less by lightly tapping on the outer ring end face.
- 2: Shaft locknut misalignment:
Adjust shaft nut misalignment to 0.005 mm or less (Fig. 1.31)
- 3: Shaft runout:
0.005 mm or less
- 4: Concentricity of rear side housing:
0.015 mm or less

The values given above are provided as an example. Define target accuracy values based on spindle size and application. If the target accuracy values cannot be met, disassemble and check the accuracy of the components again.

Fig 1.31 Adjusting Misaligned Shaft Locknut

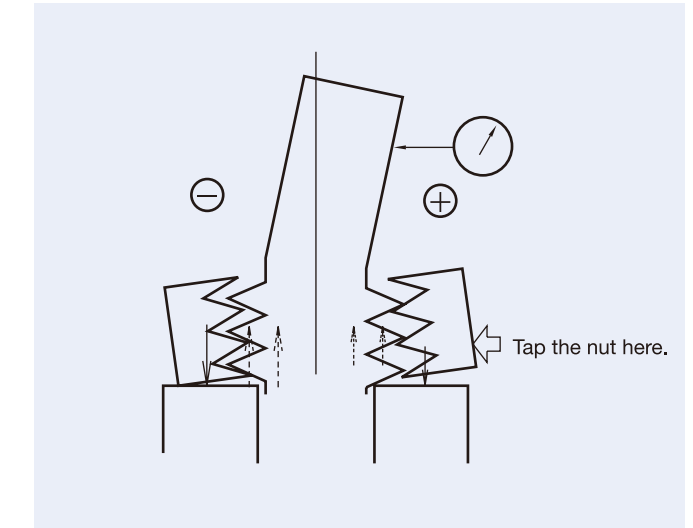
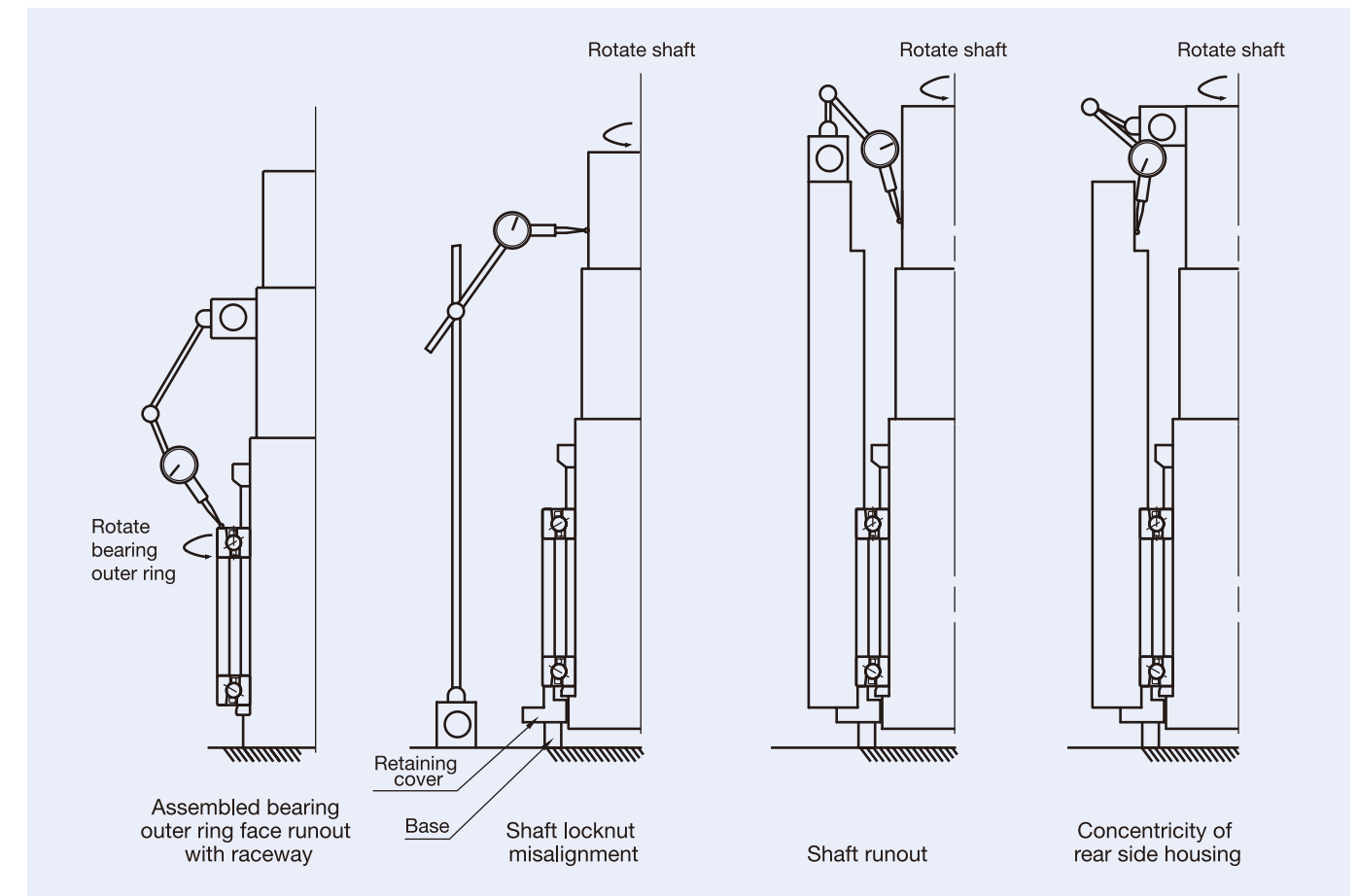

Fig 1.32 Measuring Spindle Runout



4.2 Control of Preload after Mounting of Bearings

Setting a higher preload will increase the rigidity of the bearing, but heat generation will also increase. In extreme cases it may cause seizure. Therefore, it is necessary to set the optimum preload carefully in accordance with the operating conditions and to control mounted preload. Methods for measuring preload are detailed below.

For cylindrical roller bearings, we recommend you use a GN gauge to control mounted radial preload (please refer to Page 250).

Measuring preload

There are three methods for checking the preload of bearings after they have been mounted onto a spindle: the starting torque method, the force deflection method (thrust static rigidity method), and the natural frequency method. The features of each method are summarized in Table 1.6.

For tapered roller bearings starting torque method is suitable because as shown in page 214 the axial rigidity of tapered roller bearings is not sensitive for preload amount.

Table 1.6 Methods of Measuring Mounted Preload

	Starting torque method	Force deflection method	Natural frequency method
Advantages	Suitable for heavy preload Measurement error is small if starting torque is high	Suitable for light preload	High measuring accuracy Excellent repeatability
Disadvantages	Not suitable for light preload Variation of measurement is large if starting torque is small	Not suitable for heavy preload May require large loading device Measurement may be affected by deformation of related parts	Easily influenced by measuring jig structure and spindle orientation

(1) Starting torque method

Measure the initial tangential force required to start the spindle from standstill using a push-pull gauge (Fig. 1.33). The product of the initial tangential force F and the shaft radius at the point of measurement ($d/2$) yields the starting torque T .

$$T = F \times d/2$$

Obtain the level of preload from the relationship between preload and starting torque (Fig. 1.34).

With the starting torque method, measurement is simple. However, measurement accuracy varies depending on the level of starting torque. As the starting torque is low in most high-speed machine tool spindles, the measurement error is higher.

If oil film formation in the rolling contact areas is unstable during measurement, stick-slip may occur: this is the phenomenon that rotation initially does not start even though tangential force is applied, then rotation suddenly starts as the tangential force is increased gradually. In this case, the measured force tends to be higher than the actual force. Therefore, take a sufficient number of measurements and exclude any such exaggerated measurements.

Fig. 1.33 Starting Torque Method

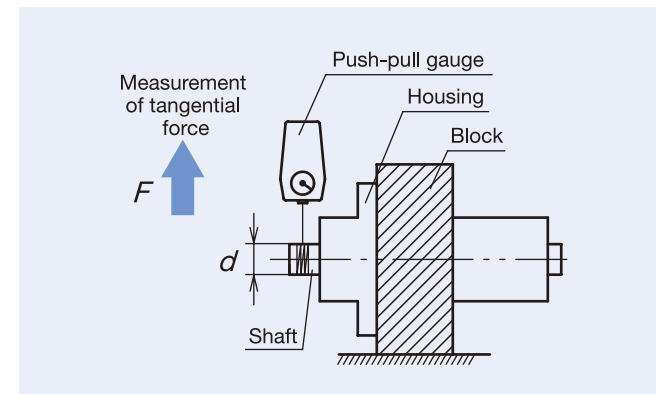
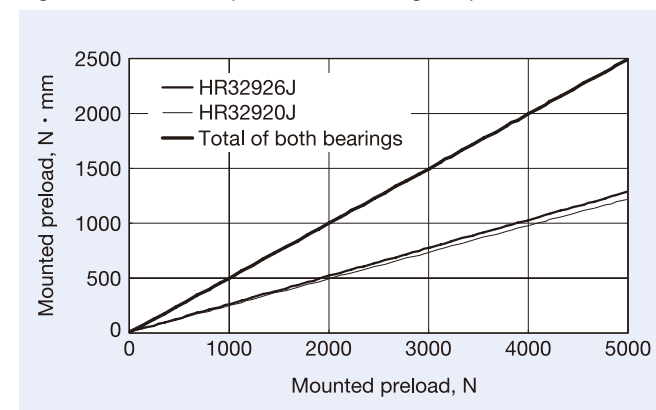

Fig. 1.34 Relationship between Starting Torque and Preload



(2) Force deflection method

Apply a thrust load to the shaft and measure its axial displacement (Fig. 1.35). The preload is obtained by the relationship between axial displacement and preload (Fig. 1.36).

This method is suitable for ball bearings since they exhibit a large change in rigidity in response to a change in preload. It is useful for spindles with moderate axial rigidity as force deflection can easily be measured. By contrast, when measuring spindles with high axial rigidity, it may be necessary to use special hydraulic equipment to apply a large enough axial load. For example, if the axial rigidity is 200 N/μm, an axial load of 2000 N will be required to deflect the spindle by 10μm.

If excessive load is applied, elastic deformation can occur in both the bearing internals and associated machine parts; in this case, the measured value tends to be lower than the actual preload.

Fig. 1.35 Force Deflection Method

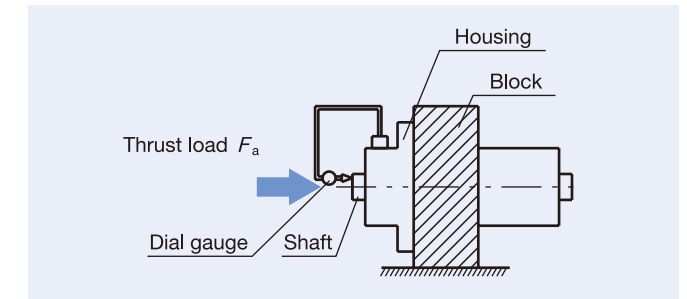
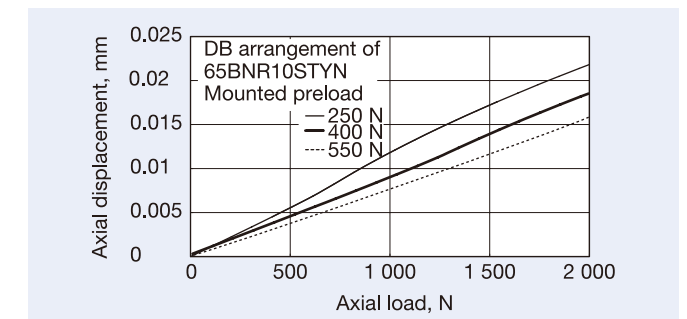

Fig. 1.36 Relationship between Axial Displacement and Preload



(3) Natural frequency method

Vibrate the shaft in the axial direction and measure its resonance frequency (Fig. 1.37).

This method is the most sensitive and repeatable method when measuring angular contact ball bearings. However, the measurement results can be affected by the measuring jig structure. In other words, when the fixing condition of spindle, spindle orientation, or both were changed, the measuring result will be affected. This means that when user adopt this natural frequency method it is desirable to do other checking method in parallel, and decide the target value at its initial production.

Fig. 1.37 Natural Frequency Method

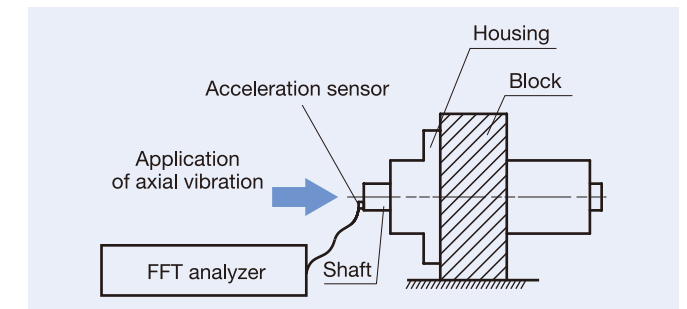
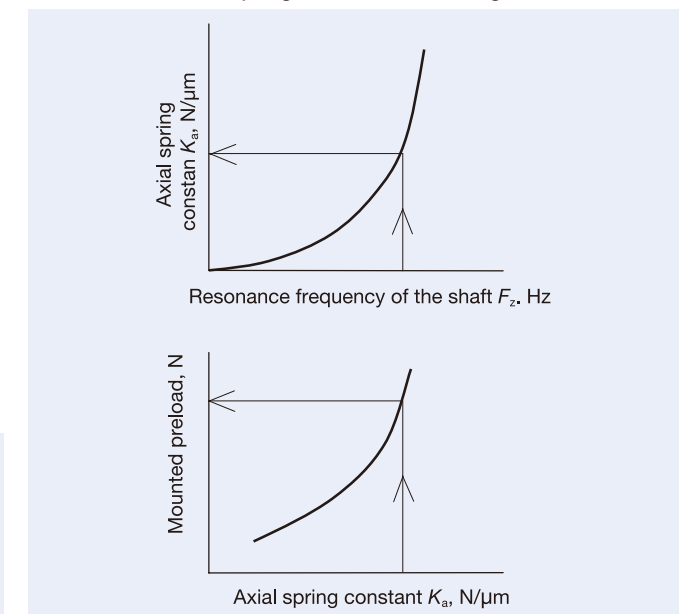

Fig. 1.38 Relationship between Resonance Frequency of Shaft and Axial Spring Constant of Bearing



Measurement of resonance frequency (F_z) of shaft in axial direction

↓

Axial spring constant (K_a) of bearing

↓

Mounted preload

$$K_a = m \left(\frac{\pi \cdot F_z}{500} \right)^2$$

K_a : Axial spring constant of bearing (N/μm)
 F_z : Resonance frequency (Hz)
 m : Mass of rotating body

Preparing for Operation

After spindle assembly has been completed, connect the spindle to the power source.

■ Connection with motor

When using V-belt drives, adjust parallelism and misalignment of the spindle pulley and the motor pulley (Fig. 2.1).

Coupling drives need to be well-balanced and checked for offset and misalignment (Fig. 2.2).

Fig. 2.1 V-belt Drive

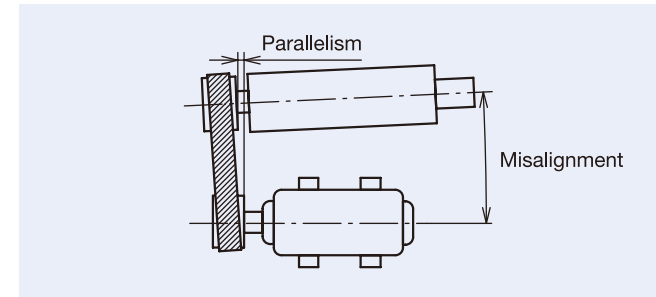
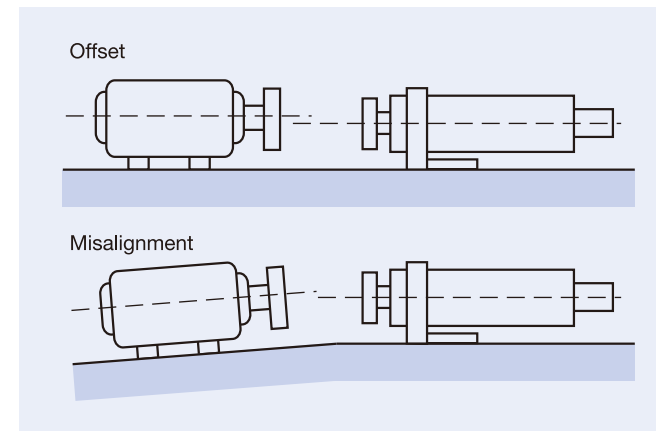

Fig. 2.2 Coupling Drive



■ Balance

Any unbalance in rotating components will cause an eccentric load during rotation due to the centrifugal force. This results in vibrations, decreased machining accuracy and decreased service life of the bearings (Fig 2.3).

Recommended balance quality grades for different types of rotors are listed in JIS B 0905. Table 2.1 and Fig 2.4 show an excerpt of this standard. Use specialized equipment when measuring ϵ (permissible residual specific unbalance) as you apply the values in Table 2.1.

Fig. 2.3 Bearing Load due to Unbalance

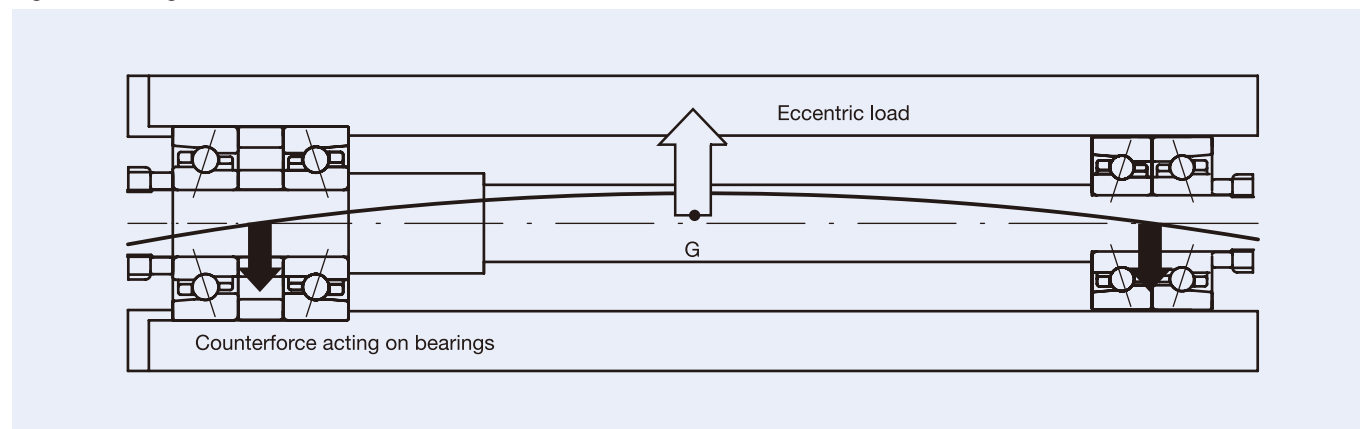
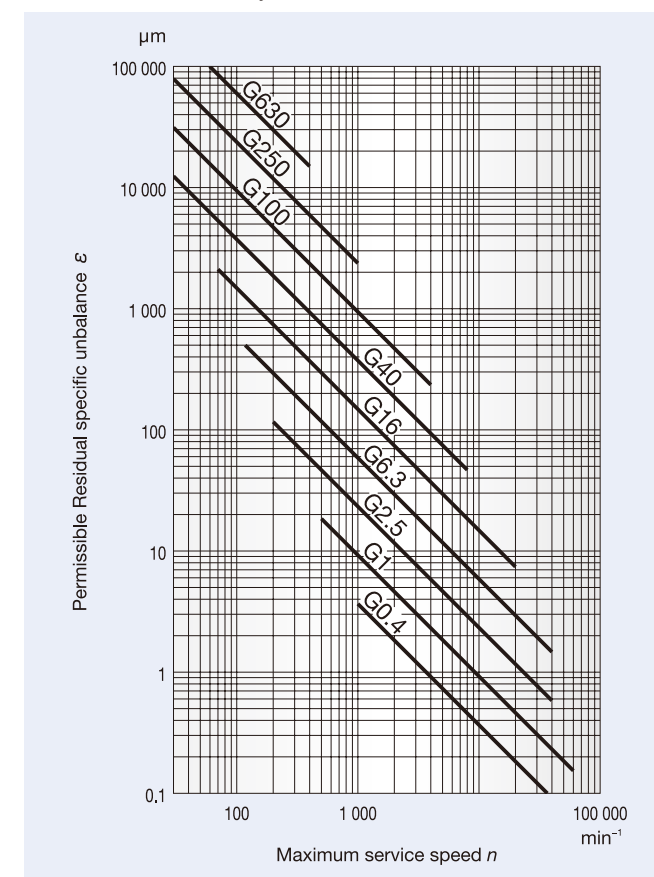

Table 2.1 Balance Quality Grades and Examples of Rotor Types

Balance Quality Grade	Rotor Type Example
G0.4	Precision grinder
G1.0	Grinding machine spindles, Small motors with special requirements
G2.5	Machine tool spindles, Medium and large motors with special requirements
G6.3	Components of machine tools and general machinery

Fig. 2.4 Permissible Residual Specific Unbalance Based on Balance Quality Grade G



clearance, mounting errors or seal friction. If there are no abnormalities, a running-in can be started.

As large equipment is impossible to turn by hand, start up without load and switch power off again immediately to allow the spindle to coast. Check for vibration, noise and abnormalities in the contact of the rotating components.

Start running-in slowly without load, then gradually increase the speed until the maximum speed is reached (page 268-269). During the test run, check for abnormal noise, excessive rise of bearing temperature, leakage or discoloration of lubricants, etc. If any abnormality is found, stop the test run immediately and inspect the machinery. If necessary, dismount the bearings for examination.

Although the temperature of the outside surface of the housing can generally help determine bearing temperature, it is better to directly measure the temperature of the outer ring using oil holes for access.

Bearing temperature should rise gradually to a steady level within one or two hours after starting operation. If problems arise in a bearing, or if an error was made in mounting, bearing temperature may increase rapidly and become abnormally high. Possible causes of such an abnormal temperature include an excessive amount of lubricant, insufficient bearing clearance, incorrect mounting, or excessive friction of the seals. In high-speed operations, an incorrect selection of bearing type or lubricating method may also cause an abnormal temperature rise.

Bearing noise can be checked with a sound detector or other instruments. Abnormal conditions are indicated by a loud metallic sound or other irregular noise. Possible causes include incorrect lubrication, insufficient accuracy of the shaft and housing, damaged bearings or ingress of contamination into the bearing.

Possible causes and countermeasures for irregularities are listed on page 275.

Operational Inspection

After mounting has been completed, conduct a test run to determine if the bearing has been mounted correctly. Small equipment may be manually operated to assure that they rotate smoothly. Items to be checked include sticking due to contamination, surface damage or dents; uneven torque caused by improper mounting or an improperly machined mounting surface; excessive torque caused by an inadequate

Running-in

If operating speed is suddenly increased after the bearings are mounted, bearings may be damaged due to insufficient lubrication, or the lubricant may deteriorate.

Proper running-in with gradual increases of operating speed is indispensable, especially for grease lubricated bearings where grease must be allowed to spread evenly. Running-in should be conducted at room temperature (15°C to 25°C) while monitoring bearing temperature.

Maximum operating temperature of the bearing should be targeted at about 60°C (50 °C at the spindle housing exterior). Do not to exceed additional 5°C. If temperature increases beyond this limit, temporarily stop the running-in process or decelerate to lower the temperature.

Some spindle assemblies incorporate both cylindrical roller bearings and angular contact ball bearings. Since cylindrical roller bearings tend to require more time than ball bearings for temperature to level off, the timing of the speed increases must be set to correspond with the cylindrical roller bearings.

Note

Spindle assemblies operating under oil mist and oil-air lubrication are at risk of a sudden temperature rise at initial operation or after the spindle assembly has not been operated for a long time. Excess oil that has collected in the oil lines of the lubrication system may suddenly flood the bearing interior, causing a temperature spike. Running-in for bearings with these lubricating systems requires much less time than for grease-based systems, and is highly recommended.

(1) Continuous running-in method

Continuous running-in works by gradually increasing the operating speed from the low speed zone. Divide the

maximum operating speed evenly into a number of stages and increase speed in increments:

1. Begin at a reasonably low operating speed.
2. Monitor temperature rise.
3. When temperature has stabilized, increase speed to the next target speed.
4. Continue repeating steps 2 and 3 until the maximum operating speed is reached.

Maximum operating speed is commonly divided into ten stages to determine the target speed for each stage. Allow between 30 min. and two hours for the temperature to stabilize before you increase speed to the next stage. Fig. 3.2 shows patterns of temperature development that help you decide whether speed may be increased or not. Determine the target speeds that are optimally suited for your application while monitoring the actual temperature on your spindle.

Although somewhat time consuming, this procedure helps machine operators to detect potential spindle defects, thus avoiding costly damage to the bearings.

Fig. 3.1 Bearing Temperature Change during Continuous Running-in

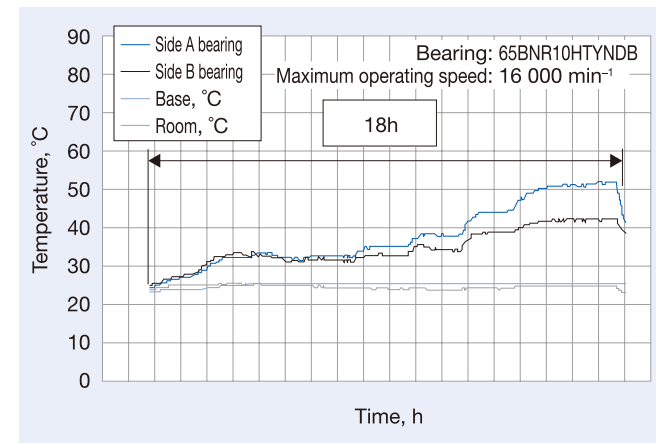
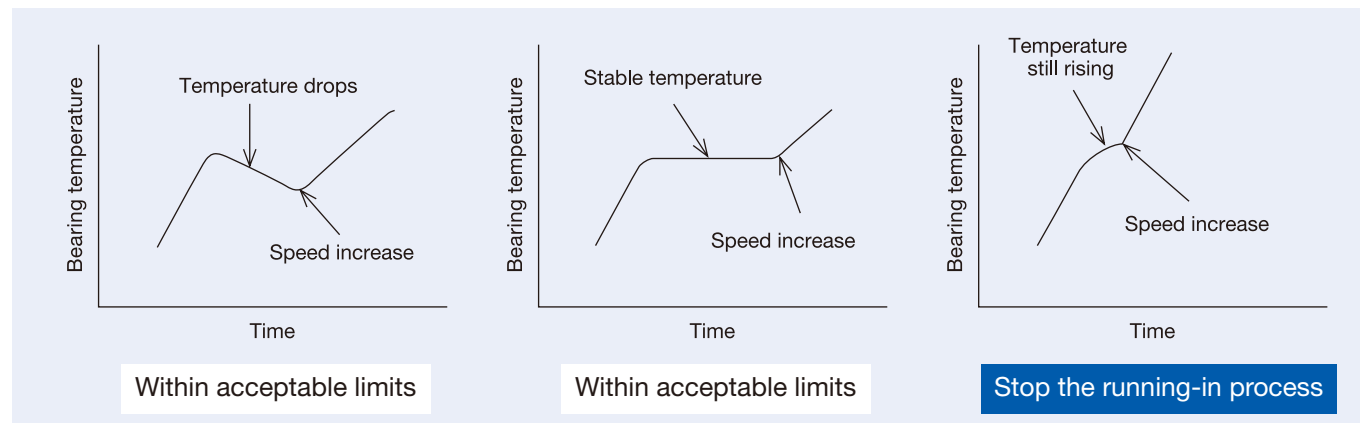

Fig. 3.2 Bearing Temperature Change during Running-in



Increase operating speed when temperature rise characteristics are within limits.

(2) Intermittent running-in method

At first, run the spindle continuously at about 500 min⁻¹ (100 min⁻¹ for larger machines) for 15 minutes to allow the grease to settle. Take the maximum operating speed and divide it into eight to ten stages to determine the maximum target speed for each stage.

1. Each stage is divided into 10 cycles that are approximately one minute long.
2. During each cycle, rapidly accelerate the spindle to the target speed for the current stage, then decelerate back to zero, and then rest for a period of 40 seconds.
3. Repeat this cycle about 10 times.
4. Continue moving up through the stages, following the above procedures, until you reach the maximum operating speed.

The temperature data shown in Fig. 3.3 were gained during intermittent running-in with a maximum operating speed of 16 000 min⁻¹, 8 speed stages and 10 cycles per stage. After the maximum operating speed is reached, we recommend continuously running the spindle at that speed for about 1 hour.

Speed increase causes a sudden supply of grease to the bearing's interior resulting in a sharp temperature rise. During intermittent running-in, the spindle is stopped to allow the temperature to stabilize. This saves time compared to the continuous running-in method.

The number of target speed stages and the number of cycles to be performed in each speed stage vary according to spindle design and arrangement. Please determine appropriate values on the actual machine.

Fig. 3.3 Cycle Structure and Bearing Temperature Change during Intermittent Running-in

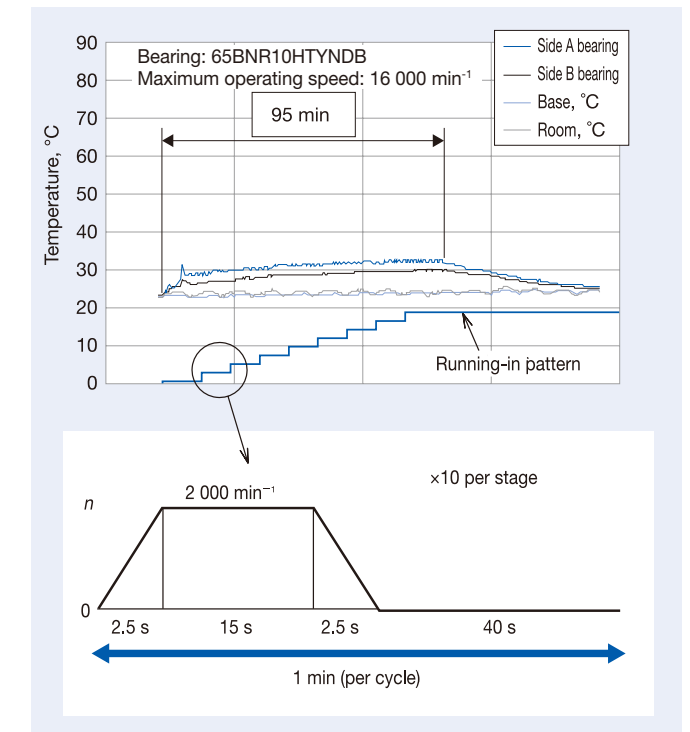

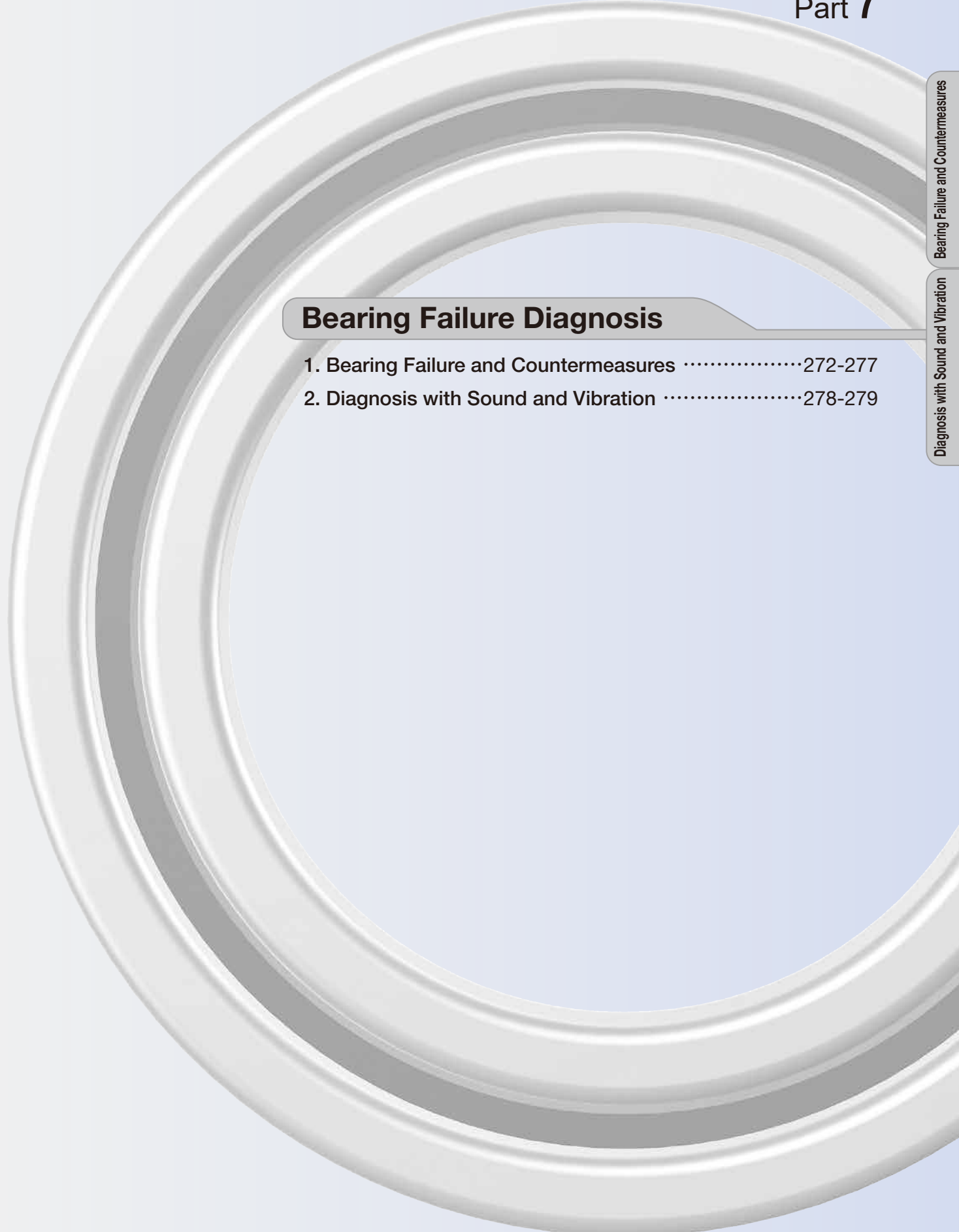

Bearing Failure Diagnosis

- 1. Bearing Failure and Countermeasures272-277
- 2. Diagnosis with Sound and Vibration278-279

Bearing Failure and Countermeasures
Diagnosis with Sound and Vibration

Maintenance, Inspection and Corrective Measures

Proper maintenance and inspection help to maintain the original performance of a bearing for as long as possible, avoid bearing problems, increase reliability and productivity, and keep operating costs low. We suggest periodic maintenance with specified procedures that should include the supervision of operating conditions, replenishment or replacement of lubricants, and the inspection of parts.

Items that should regularly be checked during operation include bearing noise, vibration, temperature, and lubrication. If any irregularity is found during operation, the cause should be determined and the proper corrective action taken after referring to Table 1.2 on page 275. If necessary, bearings should be dismantled and examined in detail.

Bearing Failure and Countermeasures







In general, if rolling bearings are used correctly they will continue to perform to their predicted fatigue life. However,



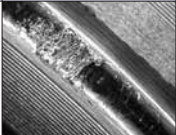







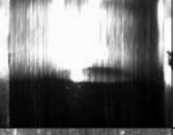

bearings often fail prematurely due to avoidable mistakes. In contrast to fatigue life, this premature failure is caused by improper mounting, handling or lubrication, ingress of contamination, or abnormal heat generation.

Possible causes of rib scoring in roller bearings, as one example, include the use of improper lubricant, a faulty lubrication system, ingress of contamination, bearing mounting errors, excessive shaft deflection, or any combination of these.

Therefore, it is difficult to determine the real cause of some premature failures by looking only at the bearing itself. If all the conditions at the time of failure and prior to failure are known, including the application, operating conditions, and the detail of spindle structure around bearings then by studying the bearing damage and its probable causes the risk of similar future failures can be reduced. The most frequent types of bearing failure, along with probable causes and countermeasures, are listed in Table 1.1.

Table 1.1 Causes and Measures for Bearing Failures

Type of Failure	Symptoms	Photo	Probable Causes	Countermeasures
Flaking	Flaking on one side of the raceway of radial bearing.		· Abnormal axial load (sliding failure of free-side bearing).	· Select a larger loose amount on housing to allow axial expansion of the shaft.
	Flaking pattern inclined relative to the raceway in radial ball bearings Flaking near the edge of the raceway and rolling surface in roller bearings.		· Improper mounting, bending of shaft · Inadequate centering · Inadequate tolerances for shaft and housing.	· Use care in mounting and centering · Select a bearing with a larger clearance · Correct the perpendicularity of shaft and housing shoulder.
	Flaking of raceway with same spacing as rolling element.		· Large shock load during mounting · Rusting while bearing is out of operation for prolonged period · Damage to cylindrical roller bearings during mounting	· Use care in mounting · Apply a rust preventative when machine operation is suspended for a long time.
	Premature flaking of raceway and rolling element.		· Insufficient clearance · Excessive load · Improper lubrication, rust, etc.	· Select proper fit, bearing clearance, and lubricant.
	Premature flaking of combined bearings.		· Excessive preload.	· Adjust the preload.
Scoring	Scoring or smearing between raceway and rolling surface.		· Inadequate initial lubrication · Excessively hard grease · High acceleration when starting operation.	· Use a softer grease · Avoid rapid acceleration.

Type of Failure	Symptoms	Photo	Probable Causes	Countermeasures
Scoring	Scoring or smearing between the end face of the rollers and guide rib.		· Inadequate lubrication · Incorrect mounting · Large axial load.	· Select proper lubricant · Modify the mounting.
Cracks	Crack in outer or inner ring.		· Excessive shock load · Excessive interference in fitting · Poor shaft cylindricity · Large fillet radius · Development of thermal cracks · Increased flaking.	· Examine load conditions · Modify the fit of bearing and sleeve · Improve accuracy in machining shaft · Correct fillet radius (the fillet radius must be smaller than the bearing chamfer).
	Crack in rolling element or broken rib.		· Increased flaking · Shock applied to rib during mounting · Dropped during handling.	· Use care in mounting and handling a bearing.
	Fracture of cage.		· Abnormal loading on cage due to incorrect mounting. · Improper lubrication	· Correct mounting · Examine the lubrication method and lubricant.
Indentations	Indentations on raceway with the same spacing as rolling element (Brinelling).		· Shock load during mounting · Excessive load while stationary	· Use care in handling the bearing.
	Indentations on raceway and rolling elements.		· Ingress of contamination such as metallic particles or grit.	· Clean the housing · Improve the seals and use clean lubricant.
Abnormal wear	False brinelling (phenomenon similar to brinelling).		· Vibration of a stationary bearing during such times as transport · Oscillating motion with small amplitude.	· Secure the shaft and housing during transport · Select a suitable lubricant · Reduce vibration by applying preload.
	Fretting, localized wear with reddish-brown wear dust at fitting surface.		· Sliding wear at a minute gap in the fitting surface.	· Increase interference · Apply oil.
	Wearing on raceway, rolling surfaces, rib and cage.		· Ingress of contamination · Incorrect lubrication and rust.	· Improve sealing capabilities · Clean the housing · Use a clean lubricant.
	Creep, scoring wear at fitting surface.		· Insufficient interference · Insufficiently secured sleeve.	· Modify fit · Tighten the sleeve properly.
Seizure	Wear of raceway, rolling elements, rib and cage. Discoloration and melting of rib surface.		· Insufficient clearance · Incorrect lubrication · Improper mounting.	· Examine fit and internal clearance of bearings · Supply an adequate amount of suitable lubricant · Examine the mounting method and quality of related parts.
Corrosion and Rust	Corrosion and rust at bearing interior or fitting surface.		· Condensation due to humidity, fretting, · Entry of corrosive substances (especially varnish solvents etc.)	· Store carefully when in a moist or hot climate · Take rust prevention measures for periods of non-running · Select suitable varnish and grease.

● Please contact NSK when bearings show this kind of symptoms.

Running Paths and Applied Loads

As the bearing rotates, the raceways of the inner ring and outer ring make contact with the rolling elements. This results in a wear path on both the rolling elements and raceways. Running paths are a source of information about the load conditions and should be carefully studied when the bearing is dismantled.

If the running paths are clearly defined, it is possible to detect whether the bearing was subjected to radial loads, axial loads or moment loads, or whether there was an excessive unevenness in housing rigidity. Running paths may point you to major mounting errors, unexpected loads or other causes of bearing damage.

Fig. 1.1 shows the running paths generated in deep groove ball bearings under various load conditions. Pattern (a) is the most common running trace generated when the inner ring

rotates under a radial load only. Patterns (e) through (h) indicate adverse conditions which usually lead to shortened service life.

Similarly, Fig 1.2 shows running paths for cylindrical roller bearings. The outer ring paths of pattern (i) indicate properly applied radial load with inner ring rotation. Running paths (j) exhibit a color shade across the width and diagonal boundaries where the load sets in. This indicates misalignment of inner and outer rings relative to each other, or shaft bending. Patterns (k) and (l) show outer ring running paths of double-row cylindrical roller bearings with inner ring rotation. While pattern (k) exhibits radial loads applied evenly to both rows, pattern (l) indicates a mismatch of bearing taper and shaft taper angle that results in an uneven preloads between the two rows.

Fig. 1.1 Typical Running Paths of Deep Groove Ball Bearings

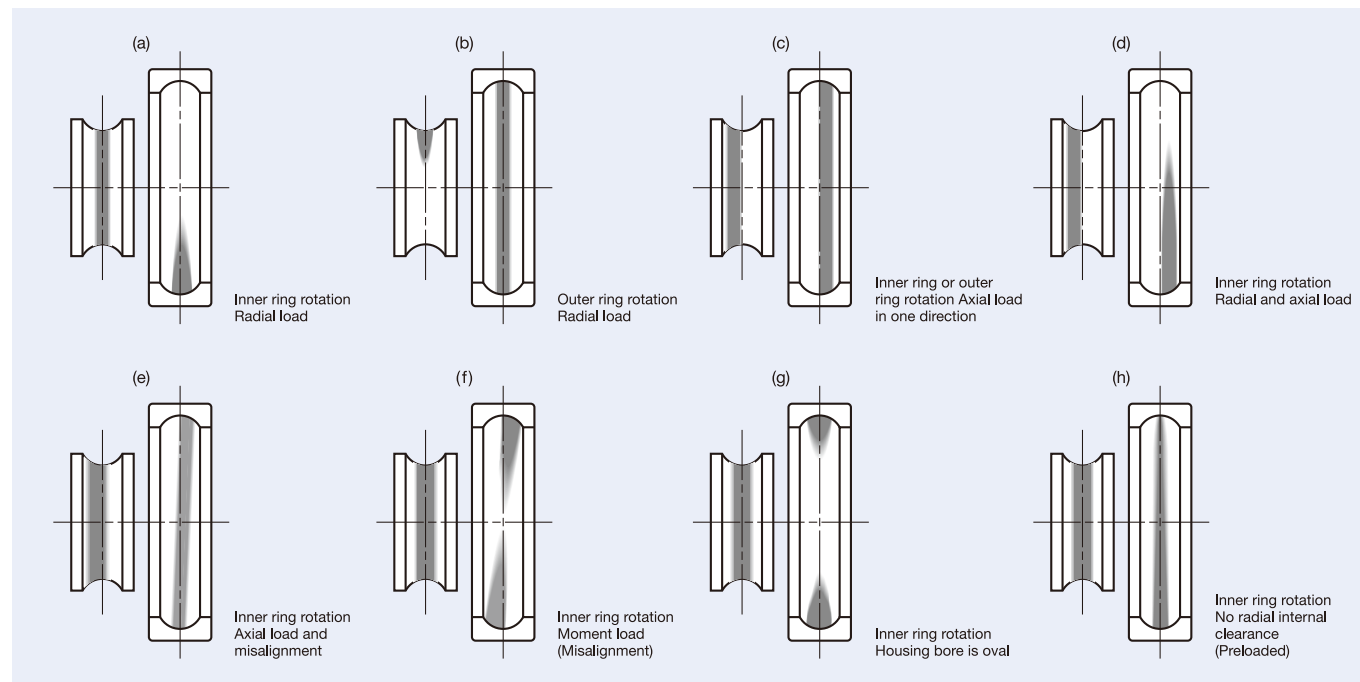

Fig. 1.2 Typical Running Paths of Roller Bearings

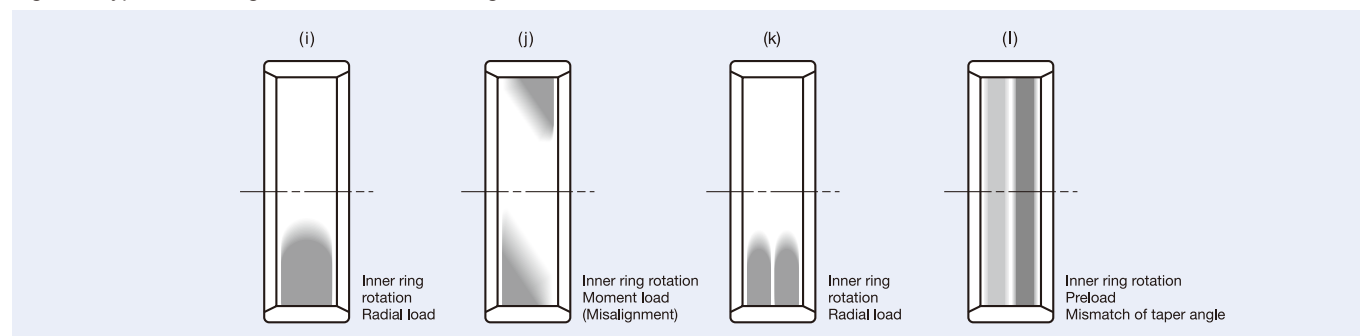

Table 1.2 Causes and Countermeasures for Operating Irregularities

Irregularities		Possible causes	Countermeasures
Noise	High-pitched metallic sound (*)	Abnormal load	Improve fit, examine internal clearance, adjust preload, correct position of housing shoulder, etc.
		Incorrect mounting	Improve machining accuracy of shaft and housing, mounting accuracy and mounting method
		Insufficient or improper lubricant	Replenish lubricant, use suitable lubricant
		Contact of rotating parts	Modify the contact area of labyrinth seal etc.
	Regular sound	Dents, corrosion or scratches on raceways due to contamination	Replace bearing, clean related parts, improve seals, use clean lubricant
		Brinelling	Replace bearing, handle bearings with care
		Flaking on raceway	Replace bearing
	Irregular sound	Excessive clearance	Examine fit and clearance, correct preload
Ingress of contamination		Consider bearing replacement, clean related parts, improve seals, use clean lubricant	
Scratches or flaking on balls		Replace bearing	
Abnormal temperature rise	Excessive amount of lubricant	Reduce amount of lubricant	
	Insufficient or improper lubricant	Replenish lubricant, use suitable lubricant	
	Abnormal load	Improve fit, examine clearance, adjust preload, correct position of housing shoulder, etc.	
	Incorrect mounting	Improve machining accuracy of shaft and housing, mounting accuracy and mounting method	
	Creep on fitted surface, excessive seal friction	Replace bearing, examine fit, correct shaft and housing, change seal type	
Vibration (Whirling of shaft)	Brinelling	Replace bearing, handle bearings with care	
	Flaking	Replace bearing	
	Incorrect mounting	Correct perpendicularity of shaft shoulder, housing shoulder and spacer end faces	
	Ingress of contamination	Replace bearing, clean related parts, improve seals, etc.	
Leakage or discoloration of lubricant	Excessive amount of lubricant, ingress of contamination, abrasion with ingress of abrasion dust	Optimize the amount of lubricant, consider replacement or selection of a different lubricant, consider bearing replacement, clean housing etc.	

(*) Squeal noise may occur when using medium- to large-sized cylindrical roller bearings and ball bearings with grease lubrication during the winter or in cold environments. Generally, such noise is not accompanied by temperature rise and has no adverse effect on rolling fatigue life or grease life. The bearings are fully functional and can continue to be used. If you are concerned that squeal noise may become a problem, feel free to contact NSK.

Some examples of bearing damage are shown in detail below.

Example 1

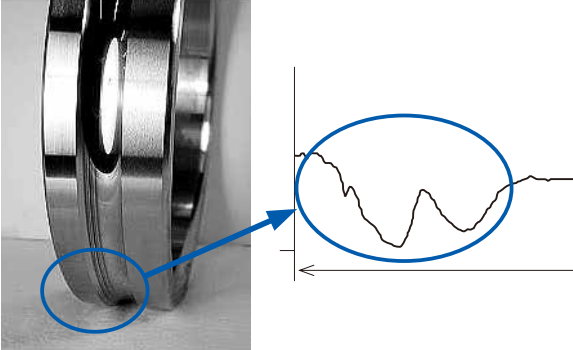

Type : Angular contact ball bearing
 Application : Machining center spindle
 Lubrication : Grease
 Symptom : Unusual noise
 Probable cause : Abnormal wear due to excessive preload
 Countermeasure : Adjust preload

Example 2

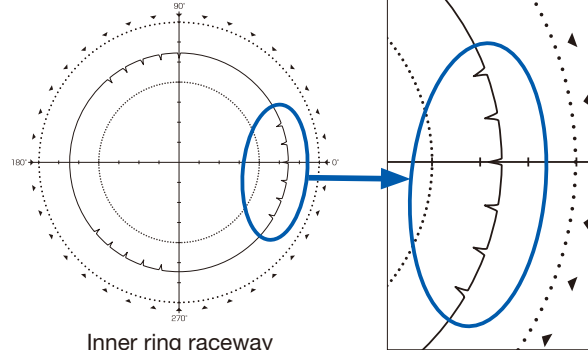

Inner ring raceway out-of-roundness

Type : Angular contact ball bearing
 Application : Machining center spindle
 Lubrication : Grease
 Symptom : Unusual noise
 Probable cause : Brinell indentations caused by a shock load
 Countermeasure : Review operating conditions

Example 3

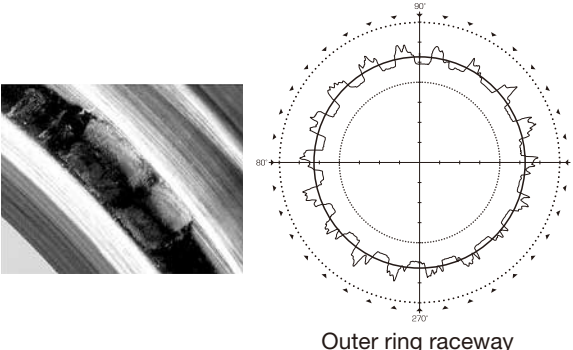

Outer ring raceway out-of-roundness

Type : Angular contact ball bearing for ball screw support
 Application : Machine tool feed shaft
 Lubrication : Grease
 Symptom : Unusual noise
 Probable cause : Fretting caused by minute vibration
 Countermeasures: Change to ceramic ball bearing
 Review stroke length
 Add a re-organization stroke for grease and balls (dummy-stroke)

Example 4

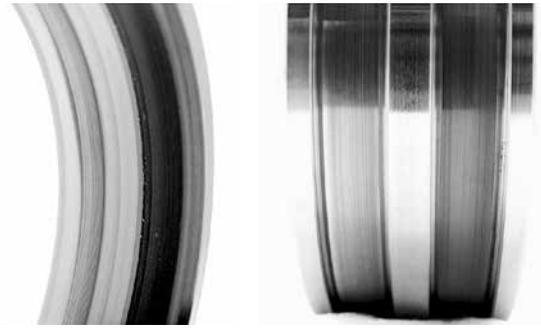

Outer ring raceway Inner ring raceway

Type : Double-row cylindrical roller bearing
 Application : Lathe spindle
 Lubrication : Grease
 Symptom : Seizure
 Probable cause : Mismatch of shaft taper angle resulting in excessive load on one row and subsequent interruption of oil film
 Countermeasure : Adjust shaft taper angle

Table 1.3 Bearing Diagnostic Chart

Type of damage	Location (Phenomenon)	Cause										Remarks			
		Handling		Bearing surrounding			Lubrication		Load		Speed				
		Storage, Shipping	Mounting	Shaft, Housing	Sealing device, Water, Debris	Temperature	Lubricant	Lubrication method	Excessive load, Shock Load	Moment load	Ultra small load		High speed, high acceleration	Oscillation, Vibration, Stationary	Bearing selection
01. Flaking	Raceway, Rolling surface		○	○	○		○	○	○	○				○	
02. Peeling	Raceway, Rolling surface				○		○	○				○	○		
	Bearing outside surfaces (Rolling contact)			○*	○		○	○							*Mating rolling part
03. Scoring	Roller end face, Rib surface		○	○	○		○	○	○	○		○			
	Cage guide surface, Pocket surface		○		○		○	○							
04. Smearing	Raceway, Rolling surface				○		○	○			○	○			
05. Fracture	Ribs, Rollers	○	○	○						○	○				
06. Cracks	Raceway rings, Rolling elements		○	○		○			○	○					
	Rib surface, Roller end face, Cage guide surface (Thermal crack)			○				○	○	○					
07. Cage damage	(Deformation), (Fracture)		○	○					○	○					
	(Wear)		○		○		○	○	○	○		○			
08. Denting	Raceway, Rolling surface (Indentation at rolling element pitch)				○			○							
	Raceway (Dents on the rolling element pitch)	○	○						○				○		
09. Pitting	Raceway, Rolling surface				○		○	○							
10. Wear	Raceway, Rolling surface, Rib surface, Roller end face		○		○		○	○							
11. Fretting	Raceway, Rolling surface	○	○	○			○	○	○			○	○		
	Bearing outside and bore, side surface (Contact with housing and shaft)		○	○					○						
12. False brinelling	Raceway, Rolling surface	○					○	○					○		
13. Creep	Fitting surface		○	○		○	○*	○*	○			○			*Loose fit
14. Seizure	Rings, Rolling elements, Cage		○	○	○		○	○	○	○		○		○	
15. Electrical corrosion	Raceway, Rolling surface		○*	○*											*Electricity passing through the rolling element
16. Rust and corrosion	Rings, Rolling elements, Cage	○	○		○	○	○	○							
17. Damage due to mounting	Raceway, Rolling surface		○	○											
18. Discoloration	Raceway ring, Rolling element, Cage					○	○	○							

Remark: This chart is not comprehensive. It lists only the more common causes for damages.

● Please contact NSK when bearings show this kind of symptoms.

Classification of Sounds and Vibrations

Sound and vibration accompany the rotation of rolling bearings. The tone and amplitude of such sound and vibration vary depending on the type of bearing, mounting conditions, operating conditions, etc. The sound and vibration of a rolling bearing can be classified under the following four chief categories and each category can be further classified into several sub-categories, as described in Table 2.1 below. However, the distinctions between the categories are not absolute. Even if some types of sound or vibration are inherent in the bearings, the volume might be related to the

manufacturing process, while some types of sound or vibration, even if they are due to manufacturing, cannot be eliminated even in normal conditions.

By recording the sounds and vibrations of a rotating machine and analyzing them, it is possible to determine the likely cause. As can be seen from the figures on the next page, a mechanically normal bearing shows a stable waveform. However, a bearing with a scratch, for example, shows a waveform with wide swings indicating large-amplitude sounds at regular intervals.

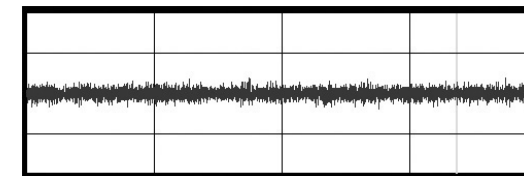

Sound waveform of a normal bearing

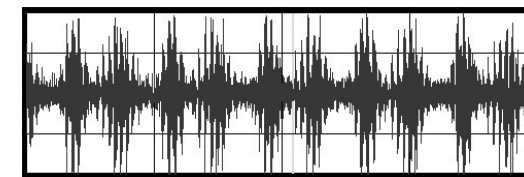

Sound waveform of a scratched bearing

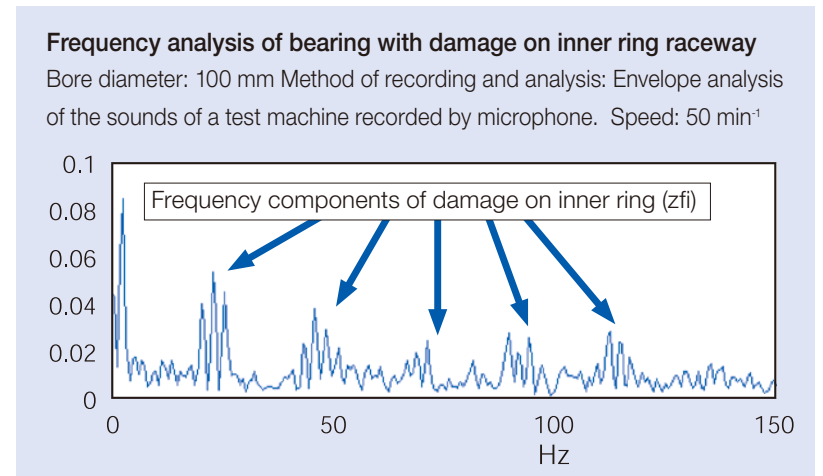

Table 2.1 Classification of sounds and vibrations in rolling bearings

	Type of sound	Vibration	Features		
			Radial (angular) direction	Axial direction	
Structural	Race noise	Free vibration of raceway ring	Continuous noise, basic unavoidable noise which all bearings generate		
	Click noise	Free vibration of raceway ring, free vibration of cage	Regular noise at a certain interval, large bearings and horizontal shaft, radial load and low rpm		
	Squeal noise	Free vibration of raceway ring	Intermittent or continuous, mostly large cylindrical roller bearings, radial load, grease lubrication, at particular speed		
	Cage noise	"CK" noise (Kacha-kacha)	Free vibration of cage	Regular noise at a certain interval, all bearing types generate it	
		"CG" noise (Gaga-gaga)	Vibration of cage	Intermittent or continuous, lubrication with particular grease	
	Tapping noise	Free vibration of cage	Certain interval, but a little irregular, under radial load and during initial stage		
	—	Rolling element passage vibration	Continuous noise, may pause occasionally (ball bearings)		
Manufacturing	Waviness noise	Vibration due to waviness	Inner ring	Continuous noise	
			Outer ring		
			Rolling element		Continuous noise, may pause occasionally (ball bearings)
Handling	Noise caused by scratches and other damage	Vibration due to flaw	Inner ring	Regular noise at a certain interval	
			Outer ring		
			Rolling element		Regular noise, may pause occasionally (ball bearings)
	Contamination noise	Vibration due to contamination	Irregular		
Others	Seal noise	Free vibration of a seal	Contact seal		
	Lubricant noise	—	Irregular		
	—	Runout	f_r	Continuous	
			f_c	Continuous	
$f_r - 2f_c$			Continuous		

n : Positive integer (1, 2, 3...)
 Z : Number of rolling elements

f_{RIN} : Ring natural frequency in radial bending mode, Hz
 f_{MI} : Natural frequency in the mode of angular vibration in inertia of outer ring-spring system, Hz

Generated frequency (frequency analysis)			Source	Countermeasures
FFT of original wave		FFT after envelope (basic No.)		
Radial (angular) direction	Axial direction			
f_{RIN}, f_{MI}	f_{AIN}, f_{AM}	—	Selective resonance of waviness (rolling friction)	Improve rigidity around the bearings, appropriate radial clearance, high-viscosity lubricant, high-quality bearings
f_{RIN}, f_{MI}	f_{AIN}, f_{AM}	Zf_c	Collision of rolling elements with inner ring or cage	Reduce radial clearance, apply preload, high-viscosity lubricant
$(\approx f_{R2N}, f_{R3N})$	—	?	Self-induced vibration caused by sliding friction at rolling surface	Reduce radial clearance, apply preload, change grease, replace with suitable bearings
Natural frequency of cage		f_c	Collision of cage with rolling elements or rings	Apply preload, high-viscosity lubricant, reduce mounting error
Natural frequency of cage		?	Self-induced vibration caused by friction at cage guide surface	Change grease, replace with suitable cage
Natural frequency of cage		Zf_c	Collision of cage and rolling element caused by grease resistance	Reduce radial clearance, apply preload, low-viscosity lubricant
Zf_c	—	—	Displacement of inner ring due to rolling element passage	Reduce radial clearance, apply preload
$nZf_i \pm f_r (nZ \pm 1 \text{ peaks})$	$nZf_i (nZ \text{ peaks})$	—	Inner ring raceway waviness, irregularity of shaft exterior	High-quality bearings, improve shaft accuracy
$nZf_c (nZ \pm 1 \text{ peaks})$	$nZf_c (nZ \text{ peaks})$	—	Outer ring raceway waviness, irregular bore of housing	High-quality bearings, improve housing bore accuracy
$2nf_b \pm f_c (2n \text{ peaks})$	$2nf_b (2n \text{ peaks})$	—	Rolling element waviness	High-quality bearings
f_{RIN}, f_{MI}	f_{AIN}, f_{AM}	Zf_i	Nicks, dents, rust, flaking on inner ring raceway	Replace bearings and handle them carefully
		Zf_c	Nicks, dents, rust, flaking on inner ring raceway	Replace bearings and handle them carefully
		$2f_b$	Nicks, dents, rust, flaking on rolling elements	Replace bearings and handle them carefully
f_{RIN}, f_{MI}	f_{AIN}, f_{AM}	Irregular	Entry of dirt and debris	Clean, improve sealing
Natural frequency of seal		(f_r)	Self-induced vibration due to friction at seal contact area	Change the seal, change the grease
?	?	Irregular	Lubricant or lubricant bubbles crushed between rolling elements and raceways	Change the grease
f_r	—	—	Irregular inner ring cross-section	High-quality bearings
f_c	—	—	Inner ring deflection due to vibration in or unequal spacing of balls	High-quality bearings
$f_r - 2f_c$	—	—	Non-linear vibration caused by anisotropic rigidity due to vibration in balls	High-quality bearings

f_i : Rotation frequency of inner ring, Hz
 f_c : Orbital revolution frequency of rolling elements, Hz
 f_{AIN} : Ring natural frequency in axial bending mode, Hz

f_{AM} : Natural frequency in the mode of axial vibration in mass of outer ring-spring system, Hz
 $f_i = f_r - f_c$
 f_b : Rotation frequency of rolling element around its center, Hz

Appendices

Tolerances for Shaft Diameters.....282-283
Tolerances for Housing Bore Diameters284-285
Values of Standard Tolerances for IT Grades.....286-287
Conversion Tables from SI (International Unit) System288
Physical and Mechanical Properties of Material289-290
Bearing Inspection Request Form291
Bearing Specifications Request Form.....292

Tolerances for Shaft Diameters

Unit: μm

Diameter classification (mm)		d6	e6	f6	g5	g6	h5	h6	h7	h8	h9	h10	js5	js6
Over	Incl.													
3	6	-30 -38	-20 -28	-10 -18	-4 -9	-4 -12	0 -5	0 -8	0 -12	0 -18	0 -30	0 -48	± 2.5	± 4
6	10	-40 -49	-25 -34	-13 -22	-5 -11	-5 -14	0 -6	0 -9	0 -15	0 -22	0 -36	0 -58	± 3	± 4.5
10	18	-50 -61	-32 -43	-16 -27	-6 -14	-6 -17	0 -8	0 -11	0 -18	0 -27	0 -43	0 -70	± 4	± 5.5
18	30	-65 -78	-40 -53	-20 -33	-7 -16	-7 -20	0 -9	0 -13	0 -21	0 -33	0 -52	0 -84	± 4.5	± 6.5
30	50	-80 -96	-50 -66	-25 -41	-9 -20	-9 -25	0 -11	0 -16	0 -25	0 -39	0 -62	0 -100	± 5.5	± 8
50	80	-100 -119	-60 -79	-30 -49	-10 -23	-10 -29	0 -13	0 -19	0 -30	0 -46	0 -74	0 -120	± 6.5	± 9.5
80	120	-120 -142	-72 -94	-36 -58	-12 -27	-12 -34	0 -15	0 -22	0 -35	0 -54	0 -87	0 -140	± 7.5	± 11
120	180	-145 -170	-85 -110	-43 -68	-14 -32	-14 -39	0 -18	0 -25	0 -40	0 -63	0 -100	0 -160	± 9	± 12.5
180	250	-170 -199	-100 -129	-50 -79	-15 -35	-15 -44	0 -20	0 -29	0 -46	0 -72	0 -115	0 -185	± 10	± 14.5
250	315	-190 -222	-110 -142	-56 -88	-17 -40	-17 -49	0 -23	0 -32	0 -52	0 -81	0 -130	0 -210	± 11.5	± 16
315	400	-210 -246	-125 -161	-62 -98	-18 -43	-18 -54	0 -25	0 -36	0 -57	0 -89	0 -140	0 -230	± 12.5	± 18
400	500	-230 -270	-135 -175	-68 -108	-20 -47	-20 -60	0 -27	0 -40	0 -63	0 -97	0 -155	0 -250	± 13.5	± 20
500	630	-260 -304	-145 -189	-76 -120	—	-22 -66	—	0 -44	0 -70	0 -110	0 -175	0 -280	—	± 22
630	800	-290 -340	-160 -210	-80 -130	—	-24 -74	—	0 -50	0 -80	0 -125	0 -200	0 -320	—	± 25
800	1 000	-320 -376	-170 -226	-86 -142	—	-26 -82	—	0 -56	0 -90	0 -140	0 -230	0 -360	—	± 28
1 000	1 250	-350 -416	-195 -261	-98 -164	—	-28 -94	—	0 -66	0 -105	0 -165	0 -260	0 -420	—	± 33
1 250	1 600	-390 -468	-220 -298	-110 -188	—	-30 -108	—	0 -78	0 -125	0 -195	0 -310	0 -500	—	± 39
1 600	2 000	-430 -522	-240 -332	-120 -212	—	-32 -124	—	0 -92	0 -150	0 -230	0 -370	0 -600	—	± 46

j5	j6	j7	k5	k6	k7	m5	m6	n6	p6	r6	r7	Diameter classification (mm)	
												Over	Incl.
-3 -2	-6 -2	-8 -4	+6 +1	+9 +1	+13 +1	+9 +4	+12 +4	+16 +8	+20 +12	+23 +15	+27 +15	3	6
+4 -2	+7 -2	+10 -5	+7 +1	+10 +1	+16 +1	+12 +6	+15 +6	+19 +10	+24 +15	+28 +19	+34 +19	6	10
+5 -3	+8 -3	+12 -6	+9 +1	+12 +1	+19 +1	+15 +7	+18 +7	+23 +12	+29 +18	+34 +23	+41 +23	10	18
+5 -4	+9 -4	+13 -8	+11 +2	+15 +2	+23 +2	+17 +8	+21 +8	+28 +15	+35 +22	+41 +28	+49 +28	18	30
+6 -5	+11 -5	+15 -10	+13 +2	+18 +2	+27 +2	+20 +9	+25 +9	+33 +17	+42 +26	+50 +34	+59 +34	30	50
+6 -7	+12 -7	+18 -12	+15 +2	+21 +2	+32 +2	+24 +11	+30 +11	+39 +20	+51 +32	+60 +41	+71 +41	50	65
+6 -9	+13 -9	+20 -15	+18 +3	+25 +3	+38 +3	+28 +13	+35 +13	+45 +23	+59 +37	+62 +43	+73 +43	65	80
+6 -11	+14 -11	+22 -18	+21 +3	+28 +3	+43 +3	+33 +15	+40 +15	+52 +27	+68 +43	+73 +51	+86 +51	80	100
+7 -11	+14 -11	+22 -18	+21 +3	+28 +3	+43 +3	+33 +15	+40 +15	+52 +27	+68 +43	+76 +54	+89 +54	100	120
+7 -13	+16 -13	+25 -21	+24 +4	+33 +4	+50 +4	+37 +17	+46 +17	+60 +31	+79 +50	+88 +80	+103 +80	120	140
+7 -16	± 16	± 26	+27 +4	+36 +4	+56 +4	+43 +20	+52 +20	+66 +34	+88 +56	+90 +98	+105 +98	140	160
+7 -18	± 18	+29 -28	+29 +4	+40 +4	+61 +4	+46 +21	+57 +21	+73 +37	+98 +62	+108 +114	+114 +114	160	180
+7 -20	± 20	+31 -32	+32 +5	+45 +5	+68 +5	+50 +23	+63 +23	+80 +40	+108 +68	+126 +132	+146 +132	180	200
—	—	—	—	+44 0	+70 0	—	+70 +26	+88 +44	+122 +78	+126 +155	+146 +155	200	225
—	—	—	—	+50 0	+80 0	—	+80 +30	+100 +50	+138 +88	+155 +185	+175 +185	225	250
—	—	—	—	+56 0	+90 0	—	+90 +34	+112 +56	+156 +100	+189 +220	+216 +220	250	280
—	—	—	—	+66 0	+105 0	—	+106 +40	+132 +66	+186 +120	+165 +250	+171 +260	280	315
—	—	—	—	+78 0	+125 0	—	+126 +48	+156 +78	+218 +140	+189 +300	+226 +300	315	355
—	—	—	—	+92 0	+150 0	—	+150 +58	+184 +92	+262 +170	+225 +370	+265 +400	355	400
—	—	—	—	+92 0	+150 0	—	+150 +58	+184 +92	+262 +170	+300 +455	+330 +455	400	450
—	—	—	—	+92 0	+150 0	—	+150 +58	+184 +92	+262 +170	+330 +520	+400 +520	450	500
—	—	—	—	+92 0	+150 0	—	+150 +58	+184 +92	+262 +170	+400 +550	+400 +550	500	560
—	—	—	—	+92 0	+150 0	—	+150 +58	+184 +92	+262 +170	+455 +600	+520 +600	560	630
—	—	—	—	+92 0	+150 0	—	+150 +58	+184 +92	+262 +170	+600 +750	+600 +750	630	710
—	—	—	—	+92 0	+150 0	—	+150 +58	+184 +92	+262 +170	+750 +900	+750 +900	710	800
—	—	—	—	+92 0	+150 0	—	+150 +58	+184 +92	+262 +170	+900 +1050	+900 +1050	800	900
—	—	—	—	+92 0	+150 0	—	+150 +58	+184 +92	+262 +170	+1050 +1200	+1050 +1200	900	1 000
—	—	—	—	+92 0	+150 0	—	+150 +58	+184 +92	+262 +170	+1200 +1350	+1200 +1350	1 000	1 120
—	—	—	—	+92 0	+150 0	—	+150 +58	+184 +92	+262 +170	+1350 +1500	+1350 +1500	1 120	1 250
—	—	—	—	+92 0	+150 0	—	+150 +58	+184 +92	+262 +170	+1500 +1650	+1500 +1650	1 250	1 400
—	—	—	—	+92 0	+150 0	—	+150 +58	+184 +92	+262 +170	+1650 +1800	+1650 +1800	1 400	1 600
—	—	—	—	+92 0	+150 0	—	+150 +58	+184 +92	+262 +170	+1800 +1950	+1800 +1950	1 600	1 800
—	—	—	—	+92 0	+150 0	—	+150 +58	+184 +92	+262 +170	+1950 +2100	+1950 +2100	1 800	2 000

Tolerances for Housing Bore Diameters

Unit: μm

Diameter classification (mm)		E6	F6	F7	G6	G7	H6	H7	H8	J6	J7	JS6	JS7
Over	Incl.												
10	18	+43 +32	+27 +16	+34 +16	+17 +6	+24 +6	+11 0	+18 0	+27 0	+6 -5	+10 -8	± 5.5	± 9
18	30	+53 +40	+33 +20	+41 +20	+20 +7	+28 +7	+13 0	+21 0	+33 0	+8 -5	+12 -9	± 6.5	± 10.5
30	50	+66 +50	+41 +25	+50 +25	+25 +9	+34 +9	+16 0	+25 0	+39 0	+10 -6	+14 -11	± 8	± 12.5
50	80	+79 +60	+49 +30	+60 +30	+29 +10	+40 +10	+19 0	+30 0	+46 0	+13 -6	+18 -12	± 9.5	± 15
80	120	+94 +72	+58 +36	+71 +36	+34 +12	+47 +12	+22 0	+35 0	+54 0	+16 -6	+22 -13	± 11	± 17.5
120	150	+110 +85	+68 +43	+83 +43	+39 +14	+54 +14	+25 0	+40 0	+63 0	+18 -7	+26 -14	± 12.5	± 20
180	250	+129 +100	+79 +50	+96 +50	+44 +15	+61 +15	+29 0	+46 0	+72 0	+22 -7	+30 -16	± 14.5	± 23
250	315	+142 +110	+88 +56	+108 +56	+49 +17	+69 +17	+32 0	+52 0	+81 0	+25 -7	+36 -16	± 16	± 26
315	400	+161 +125	+98 +62	+119 +62	+54 +18	+75 +18	+36 0	+57 0	+89 0	+29 -7	+39 -18	± 18	± 28.5
400	500	+175 +135	+108 +68	+131 +68	+60 +20	+83 +20	+40 0	+63 0	+97 0	+33 -7	+43 -20	± 20	± 31.5
500	630	+189 +145	+120 +76	+146 +76	+66 +22	+92 +22	+44 0	+70 0	+110 0	—	—	± 22	± 35
630	800	+210 +160	+130 +80	+160 +80	+74 +24	+104 +24	+50 0	+80 0	+125 0	—	—	± 25	± 40
800	1 000	+226 +170	+142 +86	+176 +86	+82 +26	+116 +26	+56 0	+90 0	+140 0	—	—	± 28	± 45
1 000	1 250	+261 +195	+164 +98	+203 +98	+94 +28	+133 +28	+66 0	+105 0	+165 0	—	—	± 33	± 52.5
1 250	1 600	+298 +220	+188 +110	+235 +110	+108 +30	+155 +30	+78 0	+125 0	+195 0	—	—	± 39	± 62.5
1 600	2 000	+332 +240	+212 +120	+270 +120	+124 +32	+182 +32	+92 0	+150 0	+230 0	—	—	± 46	± 75
2 000	2 500	+370 +260	+240 +130	+305 +130	+144 +34	+209 +34	+110 0	+175 0	+280 0	—	—	± 55	± 87.5

K5	K6	K7	M5	M6	M7	N5	N6	N7	P6	P7	Diameter classification (mm)	
											Over	Incl.
+2 -6	+2 -9	+6 -12	-4 -12	-4 -15	0 -18	-9 -17	-9 -20	-5 -23	-15 -26	-11 -29	10	18
+1 -8	+2 -11	+6 -15	-5 -14	-4 -17	0 -21	-12 -21	-11 -24	-7 -28	-18 -31	-14 -35	18	30
+2 -9	+3 -13	+7 -18	-5 -16	-4 -20	0 -25	-13 -24	-12 -28	-8 -33	-21 -37	-17 -42	30	50
+3 -10	+4 -15	+9 -21	-6 -19	-5 -24	0 -30	-15 -28	-14 -33	-9 -39	-26 -45	-21 -51	50	80
+2 -13	+4 -18	+10 -25	-8 -23	-6 -28	0 -35	-18 -33	-16 -38	-10 -45	-30 -52	-24 -59	80	120
+3 -15	+4 -21	+12 -28	-9 -27	-8 -33	0 -40	-21 -39	-20 -45	-12 -52	-36 -61	-28 -68	120	180
+2 -18	+5 -24	+13 -33	-11 -31	-8 -37	0 -46	-25 -45	-22 -51	-14 -60	-41 -70	-33 -79	180	250
+3 -20	+5 -27	+16 -36	-13 -36	-9 -41	0 -52	-27 -50	-25 -57	-14 -66	-47 -79	-36 -88	250	315
+3 -22	+7 -29	+17 -40	-14 -39	-10 -46	0 -57	-30 -55	-26 -62	-16 -73	-51 -87	-41 -98	315	400
+2 -25	+8 -32	+18 -45	-16 -43	-10 -50	0 -63	-33 -60	-27 -67	-17 -80	-55 -95	-45 -108	400	500
—	0 -44	0 -70	—	-26 -70	-26 -96	—	-44 -88	-44 -114	-78 -122	-78 -148	500	630
—	0 -50	0 -80	—	-30 -80	-30 -110	—	-50 -100	-50 -130	-88 -138	-88 -168	630	800
—	0 -56	0 -90	—	-34 -90	-34 -124	—	-56 -112	-56 -146	-100 -156	-100 -190	800	1 000
—	0 -66	0 -105	—	-40 -106	-40 -145	—	-66 -132	-66 -171	-120 -186	-120 -225	1 000	1 250
—	0 -78	0 -125	—	-48 -126	-48 -173	—	-78 -156	-78 -203	-140 -218	-140 -265	1 250	1 600
—	0 -92	0 -150	—	-58 -150	-58 -208	—	-92 -184	-92 -242	-170 -262	-170 -320	1 600	2 000
—	0 -110	0 -175	—	-68 -178	-68 -243	—	-110 -220	-110 -285	-195 -305	-195 -370	2 000	2 500

Values of Standard Tolerances for IT Grades

Basic size (mm)		Standard grade								
		IT1	IT2	IT3	IT4	IT5	IT6	IT7	IT8	IT9
Over	Incl.	Tolerances (µm)								
—	3	0.8	1.2	2	3	4	6	10	14	25
3	6	1	1.5	2.5	4	5	8	12	18	30
6	10	1	1.5	2.5	4	6	9	15	22	36
10	18	1.2	2	3	5	8	11	18	27	43
18	30	1.5	2.5	4	6	9	13	21	33	52
30	50	1.5	2.5	4	7	11	16	25	39	62
50	80	2	3	5	8	13	19	30	46	74
80	120	2.5	4	6	10	15	22	35	54	87
120	180	3.5	5	8	12	18	25	40	63	100
180	250	4.5	7	10	14	20	29	46	72	115
250	315	6	8	12	16	23	32	52	81	130
315	400	7	9	13	18	25	36	57	89	140
400	500	8	10	15	20	27	40	63	97	155
500	630	9	11	16	22	32	44	70	110	175
630	800	10	13	18	25	36	50	80	125	200
800	1 000	11	15	21	28	40	56	90	140	230
1 000	1 250	13	18	24	33	47	66	105	165	260
1 250	1 600	15	21	29	39	55	78	125	195	310
1 600	2 000	18	25	35	46	65	92	150	230	370
2 000	2 500	22	30	41	55	78	110	175	280	440
2 500	3 150	26	36	50	68	96	135	210	330	540

Standard grade									Basic size (mm)	
IT10	IT11	IT12	IT13	IT14	IT15	IT16	IT17	IT18		
		Tolerances (mm)							Over	Incl.
40	60	0.10	0.14	0.25	0.40	0.60	1.00	1.40	—	3
48	75	0.12	0.18	0.30	0.48	0.75	1.20	1.80	3	6
58	90	0.15	0.22	0.36	0.58	0.90	1.50	2.20	6	10
70	110	0.18	0.27	0.43	0.70	1.10	1.80	2.70	10	18
84	130	0.21	0.33	0.52	0.84	1.30	2.10	3.30	18	30
100	160	0.25	0.39	0.62	1.00	1.60	2.50	3.90	30	50
120	190	0.30	0.46	0.74	1.20	1.90	3.00	4.60	50	80
140	220	0.35	0.54	0.87	1.40	2.20	3.50	5.40	80	120
160	250	0.40	0.63	1.00	1.60	2.50	4.00	6.30	120	180
185	290	0.46	0.72	1.15	1.85	2.90	4.60	7.20	180	250
210	320	0.52	0.81	1.30	2.10	3.20	5.20	8.10	250	315
230	360	0.57	0.89	1.40	2.30	3.60	5.70	8.90	315	400
250	400	0.63	0.97	1.55	2.50	4.00	6.30	9.70	400	500
280	440	0.70	1.10	1.75	2.80	4.40	7.00	11.00	500	630
320	500	0.80	1.25	2.00	3.20	5.00	8.00	12.50	630	800
360	560	0.90	1.40	2.30	3.60	5.60	9.00	14.00	800	1 000
420	660	1.05	1.65	2.60	4.20	6.60	10.50	16.50	1 000	1 250
500	780	1.25	1.95	3.10	5.00	7.80	12.50	19.50	1 250	1 600
600	920	1.50	2.30	3.70	6.00	9.20	15.00	23.00	1 600	2 000
700	1 100	1.75	2.80	4.40	7.00	11.00	17.50	28.00	2 000	2 500
860	1 350	2.10	3.30	5.40	8.60	13.50	21.00	33.00	2 500	3 150

Remarks 1. Standard tolerance grades IT14 to IT18 shall not be used for basic sizes less than or equal to 1 mm.
 2. Values for standard tolerance grades IT1 to IT5 for basic size over 500 mm are included for experimental use.

Conversion Tables from SI (International Unit) System

The values accompanied by (*) in the marked boxes denote SI units.

Comparison of SI, CGS and Engineering Units (Gravitational Metric System)

Unit System	Length	Mass	Time	Temperature	Acceleration	Force	Stress	Pressure	Energy	Power
SI	m	kg	s	K, °C	m/s ²	N	Pa	Pa	J	W
CGS System	cm	g	s	°C	Gal	dyn	dyn/cm ²	dyn/cm ²	erg	erg/s
Engineering Units	m	kgf·s ² /m	s	°C	m/s ²	kgf	kgf/m ²	kgf/m ²	kgf·m	kgf·m/s

Prefixes Used in SI System

Multiples	Prefix	Code	Multiples	Prefix	Code
10 ¹⁸	Exa	E	10 ⁻¹	Deci	d
10 ¹⁵	Peta	P	10 ⁻²	Centi	c
10 ¹²	Tera	T	10 ⁻³	Milli	m
10 ⁹	Giga	G	10 ⁻⁶	Micro	μ
10 ⁶	Mega	M	10 ⁻⁹	Nano	n
10 ³	Kilo	k	10 ⁻¹²	Pico	p
10 ²	Hecto	h	10 ⁻¹⁵	Femto	f
10	Deca	da	10 ⁻¹⁸	Ato	a

Force	*N	dyn	kgf
	1	1×10 ⁵	1.01972×10 ⁻¹
	1×10 ⁻⁵	1	1.01972×10 ⁻⁶
	9.80665	9.80665×10 ⁵	1

Stress	*Pa	*MPa or N/mm ²	kgf/mm ²	kgf/cm ²
	1	1×10 ⁻⁶	1.01972×10 ⁻⁷	1.01972×10 ⁻⁵
	1×10 ⁶	1	1.01972×10 ¹	
	9.80665×10 ⁶	9.80665	1	
	9.80665×10 ⁴	9.80665×10 ⁻²	1×10 ²	
			1	

Pressure	*Pa	bar	kgf/cm ²	atm	mmH ₂ O	mmHg or Torr
	1	1×10 ⁻⁵	1×10 ⁻⁵	1.01972×10 ⁻⁵	9.86923×10 ⁻⁶	1.01972×10 ⁻¹
	1×10 ⁵	1	1.01972	9.86923×10 ⁻¹	1.01972×10 ⁴	7.50062×10 ²
	9.80665×10 ⁴	9.80665×10 ⁻¹	1	9.67841×10 ⁻¹	1×10 ⁴	7.35559×10 ²
	1.01325×10 ⁵	1.01325	1.03323	1	1.03323×10 ⁴	7.60000×10 ²
	9.80665	9.80665×10 ⁻⁵	1×10 ⁻⁴	9.67841×10 ⁻⁵	1	7.35559×10 ⁻²
	1.33322×10 ²	1.33322×10 ⁻³	1.35951×10 ⁻³	1.31579×10 ⁻³	1.35951×10	1

Note: 1Pa=1N/m²

Viscosity	*Pa·s	cP	P
	1	1×10 ³	1×10
	1×10 ⁻³	1	1×10 ⁻²
	1×10 ⁻¹	1×10 ²	1

Note: 1Pa=1dyn·s/cm²=1g/cm·s, 1Pa·s=1N·s/m², 1cP=1mPa·s

Thermal Conductivity	*W/(m·K)	kcal _{IT} /(h·m·°C)
	1	8.59845×10 ⁻¹
	1.16300	1

Heat Transfer Coefficient	*W/(m ² ·K)	kcal _{IT} /(h·m ² ·°C)
	1	8.59845×10 ⁻¹
	1.16300	1

Note: 1St=1cm²/s, 1cSt=1mm²/s,

Energy, Work, Amount of Heat	*J	kW·h	kgf·m	kcal _{IT}
	1	2.77778×10 ⁻⁷	1.01972×10 ⁻¹	2.38846×10 ⁻⁴
	3.600×10 ⁶	1	3.67098×10 ⁵	
	9.80665	2.272407×10 ⁻⁶	1	
	4.18680×10 ³	1.16300×10 ⁻³	4.26935×10 ²	
			1	

Note: 1J=1W·s, 1W·h=3600W·s 1cal_{IT}=4.186 8J

Power, Thermal Flow	*W	kgf·m/s	PS	kcal _{IT} /h
	1	1.01972×10 ⁻¹	1.35962×10 ⁻³	8.59845×10 ⁻¹
	9.80665	1	1.33333×10 ⁻²	
	7.355×10 ²	7.5×10	1	
	1.16300	1.18593×10 ⁻¹	1.58124×10 ⁻³	
			1	

Note: 1W=1J/s, PS : Metric horsepower

Physical and Mechanical Properties of Material

Application	Material	Heat treatment	Density g/cm ³	Specific heat KJ/(kg K)	Thermal conductivity W/(m K)	Electric resistance μΩ·cm	Coefficient of linear expansion (0°-100°C) ×10 ⁻⁷ /°C	Young's modulus MPa	Yield point MPa	Tensile strength MPa	Elongation %	Hardness HB		
Bearing	High-carbon chrome bearing steel No.2 SUJ2	Quenching, tempering	7.83	0.47	46	22	12.5	208 000	1 370	1 570 -1 960	Max. 0.5	650 -740		
		Spheroidizing annealing	7.86						11.9	420	647	27	180	
	Chrome steel SCr420	Quenching, Low temp. tempering	7.83		48	21	12.8		882	1 225	15	370		
	Nickel-chromium-molybdenum steel SAE4320 (SNCM420)	Quenching, Low temp. tempering	7.83		44	20	11.7		902	1 009	16	**293 -375		
	Nickel-chromium-molybdenum steel SNCM815	Quenching, Low temp. tempering	7.89		40	35	-		-	Min. *1 080	Min. *12	*311 -375		
	Martensitic stainless steel SUS440C	Quenching, Low temp. tempering	7.68		0.46	24	60		10.1	200 000	1 860	1 960	-	**580
	Cold rolled steel plate SPCC	Annealing	7.86		0.47	59	15		11.6	206 000	-	Min. *275	Min. *32	-
	Carbon steel for machine structure S25C	Annealing	7.86		0.48	50	17		11.8	323	431	33	120	
	High-tension brass CAC301 (HB _S C1)		8.5		0.38	123	6.2		19.1	103 000	-	Min. *431	Min. *20	-

Notes *Standard value of JIS or reference value.

**The hardness is usually expressed using the Rockwell C scale, but for comparison, it is converted into Brinell hardness.

Reference Proportional limits of SUJ2 and SCr420 are 833 MPa (85kgf/mm²) and 440 MPa (45kgf/mm²) respectively.

Physical and Mechanical Properties of Material

Application	Material	Heat treatment (°C)	Density g/cm ³	Specific heat KJ/(kg K)	Thermal conductivity W/(m K)	Electric resistance μΩ·cm	Coefficient of linear expansion (0°-100°C) ×10 ⁻⁶ /°C	Young's modulus MPa	Yield point MPa	Tensile strength MPa	Elongation %	Hardness HB	
Shaft	Carbon steel for machine structure S45C	Quenching, 650 °C tempering	7.83	0.48	47	18	12.8	207 000	440	735	25	217	
	Chrome steel SCr430	Quenching, 520 to 620 °C fast cooling											22
	Chrome steel SCr440	Quenching, 520 to 620 °C fast cooling			12.5	23	208 000	Min. *784	Min. *930	Min. *13	*269 -331		
	Chrome Molybdenum steel SCM420	Quenching, 150 to 200 °C air cooling										48	21
	Nickel-chromium-molybdenum steel SNCM439	Quenching, 650 °C tempering			38	30	11.3	207 000	920	1 030	18		
	Low carbon cast steel SC46	Normalizing										-	-
	Martensitic stainless steel SUS420J2	1038 °C oil cooling, 400 °C air cooling.			7.75	0.46	22	55	200 000	1 440	1 650	10	400
Housing	Gray cast iron FC200	Casting	7.3	0.50	43	-	10.4	98 000	-	Min. *200	-	Max. *217	
	Spheroidal graphite cast iron FCD400	Casting	7.0	0.48	20	-	11.7		Min. *250	Min. *400	Min. *12	Max. *201	
	Pure aluminum A1100	Annealing	2.69	0.90	222	3.0	23.7	70 600	34	78	35	-	
	Aluminum alloy for sand casting AC4C	Casting	2.68	0.88	151	4.2	21.5	72 000	88	167	7	-	
	Aluminum alloy for die casting ADC10	Casting	2.74	0.96	96	7.5	22.0	71 000	167	323	4	-	
	Austenitic stainless steel SUS304	Annealing	8.03	0.50	15	72	15.7-16.8	193 000	245	588	60	150	

Notes *Standard value of JIS or reference value.

Bearing Investigation Request Form

Please complete the form below and send to your nearest NSK sales office if you wish to have a bearing investigated.

Investigation Request for Super Precision Bearings

Company name: _____ Reference No. of previous NSK reports: _____

Attachments: Structural drawing attached: Yes No Other attachments: Yes No

● Symptoms Observed symptoms: Abnormal noise Seizure Lockup Excessive temperature rise Vibration
 Crack on machined surface Poor accuracy Entry of coolant Others

Bearing condition: Seized Sticks when turned by hand Adhesion of foreign matter Discolored grease

Abnormal noise: Synchronous with rotation Not synchronous with rotation Continuous Not continuous In low speed operation

Failure occurred during: Routine operation In-house test Running-in Development evaluation Other ()

Time bearing was in service: _____ months, _____ hours Actual operating time: _____ months (_____ years _____ days)
 Full time operation Operation in _____ shift(s) per day

Further details of operating conditions: _____

● Conditions of use: Machine type: Machining center Lathe Grinder Others () Production machine Test Machine

Bearing position: Spindle Ball screw support Automatic Tool Changer Motor Other ()

Model No.: _____

Spindle position: Vertical Horizontal Swiveling

Drive type: Built-in motor spindle Belt drive Direct drive Gear drive Other ()

Maximum speed: _____ min⁻¹ Speed during operation: _____ min⁻¹ Regular speed: _____ min⁻¹

Lubrication: Grease Oil-air Oil mist Circulating lubrication Other ()
 MTE MTS NBU 15 NBU 8 EP Alvania S2 Viscosity (_____ cSt)

Coolant: Yes Brand name: _____ No Set temperature of cooling oil: _____ °C Synchronized with room temperature: + _____ °C
 Temperature control: Oil cooling unit (OCU) Control at OCU outlet Control at OCU inlet

Bearing arrangement: (example: Angular contact ball bearing \odot Cylindrical roller bearing \square , \square With Spacers $\odot = \odot$ With Spring $\text{WWW} \odot$)

Spindle front (tool/chuck) - for vertical spindles, please indicate top and bottom _____ Spindle rear _____

(Please enter bearing serial No. and indicate the mounting position as well as the direction of the bearing, e.g. whether row A faces the chuck or the rear side, etc.)

● Bearing: Front-side (fixed side) bearing Serial No.: _____ Rear-side (free side) bearing Serial No.: _____

Designation: _____ Designation: _____

Mounted clearance/preload, amount of adjustment by spacers: _____ Mounted clearance/preload, amount of adjustment by spacers: _____

Jacket cooling: Yes No Sleeve: Yes No Jacket cooling: Yes No Sleeve: Yes No

Spacer Width: 1st Spacer _____ mm, 2nd Spacer _____ mm, 3rd Spacer _____ mm Spacer Width: 1st Spacer _____ mm, 2nd Spacer _____ mm, 3rd Spacer _____ mm

Shaft bore: _____ mm Housing outside diameter: _____ mm Shaft bore: _____ mm Housing outside diameter: _____ mm

Inner ring temp.: _____ °C Outer ring temp.: _____ °C Inner ring temp.: _____ °C Outer ring temp.: _____ °C

Shaft fit: _____ Housing fit: _____ Shaft fit: _____ Housing fit: _____

● Comments, suspected causes, further observations:

Appendices

Bearing Specification Request Form

To request bearing specification, please complete the form below and send to your nearest NSK sales office.

Specification Request for Super Precision Bearings

Company name: _____

Your reason for requesting specification:

(Example: to increase spindle rigidity, to avoid previous bearing damage, etc.)

Attachments: Yes No

● Specification: Machine type: Machining center Lathe Grinder Other (_____)

Model No.: _____

Orientation: Vertical Horizontal Swiveling

Drive type: Built-in motor spindle Belt drive Direct drive Gear drive

Maximum speed: _____ min⁻¹ Unclamping force: _____ N

Lubrication: Grease Oil-air Oil mist Circulating lubrication

Other (_____)

Bearing arrangement: (example: Angular contact ball bearing \oslash Cylindrical roller bearing $\square\square$, \square Spacers $\oslash = \oslash$ Spring $\text{WM} \oslash$)

(If currently using bearings, please provide the designation)
 Front side bearings: _____
 Rear side bearings: _____

Shaft material: _____ Housing material: _____

Front-side (fixed side) bearing

Designation: _____

Bore diameter: _____ mm Outside diameter: _____ mm

Combined width: _____ mm Accuracy class: _____

Clearance/Preload: _____ (e.g. EL, 800N, CC9)

Jacket cooling: Yes No Sleeve: Yes No

Spacer Width: 1st Spacer _____ mm, 2nd Spacer _____ mm,
 3rd Spacer _____ mm

Shaft bore: _____ mm Housing outside diameter: _____ mm

Inner ring temp.: _____ °C Outer ring temp.: _____ °C

Shaft fit: _____

Housing fit: _____

Rear-side (free side) bearing

Designation: _____

Bore diameter: _____ mm Outside diameter: _____ mm

Combined width: _____ mm Accuracy class: _____

Clearance/Preload: _____ (e.g. EL, 800N, CC9)

Jacket cooling: Yes No Sleeve: Yes No

Spacer Width: 1st Spacer _____ mm, 2nd Spacer _____ mm,
 3rd Spacer _____ mm

Shaft bore: _____ mm Housing outside diameter: _____ mm

Inner ring temp.: _____ °C Outer ring temp.: _____ °C

Shaft fit: _____

Housing fit: _____

● Room to write down your priorities, comments, etc.

Detail your requests in order of importance. Example: 1. Rolling fatigue life 20 000 hours or more, 2. Mounted axial rigidity 100N/ μ m, etc.
 - Please understand it may not always be possible to meet all of the requested criteria.

※Note: If you wish to request calculation of service life under external load, please provide additional information on the load conditions (Load point, amount and direction of load, rotational speed, duty cycle in %) and the spindle structure (spindle dimensions, distance between bearings).

Worldwide Sales Offices

P: Phone F: Fax ☆: Head Office

NSK LTD.-HEADQUARTERS, TOKYO, JAPAN

Nissei Bldg., 1-6-3 Ohsaki, Shinagawa-ku, Tokyo 141-8560, Japan
P: +81-3-3779-7111 F: +81-3-3779-7431

●Africa

South Africa:

NSK SOUTH AFRICA (PTY) LTD.

SANDTON 25 Galaxy Avenue, Linbro Business Park, Sandton 2146, South Africa
P: +27-011-458-3600 F: +27-011-458-3608

●Asia and Oceania

Australia:

NSK AUSTRALIA PTY. LTD.

MELBOURNE ☆ 100 Logis Boulevard, Dandenong South, Victoria, 3175, Australia

P: +61-3-9765-4400 F: +61-3-9765-4466

SYDNEY Suite A315, 20 Lexington Drive, Bella Vista, New South Wales, 2153, Australia

P: +61-2-9839-2300 F: +61-2-8824-5794

BRISBANE 1/69 Selhurst Street, Coopers Plains, Queensland 4108, Australia

P: +61-7-3347-2600 F: +61-7-3345-5376

PERTH Unit 1, 71 Tacoma Circuit, Canning Vale, Western Australia 6155, Australia

P: +61-8-9256-5000 F: +61-8-9256-1044

New Zealand:

NSK NEW ZEALAND LTD.

AUCKLAND Unit F, 70 Business Parade South, Highbrook, Business Park Auckland 2013, New Zealand

P: +64-9-276-4992 F: +64-9-276-4082

China:

NSK (SHANGHAI) TRADING CO., LTD.

JIANGSU No.8 NSK Rd., Huaqiao Economic Development Zone, Kunshan, Jiangsu, China (215332)
P: +86-512-5796-3000 F: +86-512-5796-3300

NSK (CHINA) INVESTMENT CO., LTD.

JIANGSU ☆ No.8 NSK Rd., Huaqiao Economic Development Zone, Kunshan, Jiangsu, China (215332)
P: +86-512-5796-3000 F: +86-512-5796-3300

BEIJING Room 1906, Beijing Fortune Bldg., No.5 Dong San Huan Bei Lu, Chao Yang District, Beijing, China (100004)
P: +86-10-6590-8161 F: +86-10-6590-8166

TIAN JIN Unit 4604, 46/F., Metropolitan Tower, 183 Nanjing Road, Heping District, Tianjin, China (300051)
P: +86-22-8319-5030 F: +86-22-8319-5033

CHANGCHUN Room 902-03, Changchun Hongwell International Plaza, No.3299 Renmin Street, Changchun, Jilin, China (130061)
P: +86-431-8898-8682 F: +86-431-8898-8670

SHENYANG No.7, 15 Street, Shenyang Economic & Technological Development Area, Shenyang, Liaoning, China (110141)
P: +86-24-2550-5017 F: +86-24-2334-2058

DALIAN Room 1805 Xiwang Tower, No.136 Zhongshan Road, Zhongshan District, Dalian, Liaoning, China (116001)
P: +86-411-8800-8168 F: +86-411-8800-8160

NANJING Room A1 22F, Golden Eagle International Plaza, No.89 Hanzhong Road, Nanjing, Jiangsu, China (210029)
P: +86-25-8472-6671 F: +86-25-8472-6687

FUZHOU Room 1801-1811, B1#1A Class Office Building, Wanda Plaza, No.8 Aojiang Road, Fuzhou, China (350009)
P: +86-591-8380-1030 F: +86-591-8380-1225

WUHAN Room 1512, No.198Yuncaí Road, Office Building, Oceanwide City Square, JiangHan, District, WuHan, China (400039)
P: +86-27-8556-9630 F: +86-27-8556-9615

QINGDAO Room 802, Farlory International Plaza, No.26 Xianggang Zhong Road, Shinan District, Qingdao, Shandong, China (266071)
P: +86-532-5568-3877 F: +86-532-5568-3876

GUANGZHOU Room 1011-16, Yuexiu Financial Tower, No.28 Zhujiang Road East, Zhujiang New Town, Guangzhou, Guangdong, China (510627)
P: +86-20-3817-7800 F: +86-20-3786-4501

CHANGSHA Room 3209, Huayuan International Center, No.36, Section 2, Xiangjiang Middle Road, Tianxin District, Changsha, Hunan, China (410002)
P: +86-731-8571-3100 F: +86-731-8571-3255

LUOYANG Room 955, HUA-YANG PLAZA HOTEL, NO.88 Kaixuan W.Rd., Jian Xi District, Luoyang,Henan Province, China (471003)
P: +86-379-6069-6188 F: +86-379-6069-6180

XI'AN Room 1007, B Changan Metropolis Center, No.88 Nanguanzheng Steet, Xi'an, Shanxi, China (710068)
P: +86-29-8765-1896 F: +86-29-8765-1895

CHONGQING Room 612, Commercial Apartment, Athestel Hotel, No.288, Keyuan Rd.4, Jiulongpo District, Chongqing, China (400039)
P: +86-23-6806-5310 F: +86-23-6806-5292

CHENGDU Room1117, Lippo Tower, No.62 North Kehua Road, Chengdu, Sichuan, China (610041)
P: +86-28-8528-3680 F: +86-28-8528-3690

NSK CHINA SALES CO., LTD.

JIANGSU No.8 NSK Rd., Huaqiao Economic Development Zone, Kunshan, Jiangsu, China (215332)
P: +86-512-5796-3000 F: +86-512-5796-3300

NSK HONG KONG LTD.

HONG KONG ☆ Suite 705, 7th Floor, South Tower, World Finance Centre, Harbour City, T.S.T, Kowloon, Hong Kong, China

P: +852-2739-9933 F: +852-2739-9323

SHENZHEN Room 624-626, 6/F, Kerry Center, Renminnan Road, Shenzhen, Guangdong, China
P: +86-755-25904886 F: +86-755-25904883

Taiwan:

TAIWAN NSK PRECISION CO., LTD.

TAIPEI ☆ 10F-A6, No.168, Sec.3, Nanjing East Rd., Zhongshan Dist., Taipei City 104, Taiwan

P: +886-2-2772-3355 F: +886-2-2772-3300

TAICHUNG 3F. -2, No. 540, Sec. 3, Taiwan Blvd., Xitun Dist., Taichung City 407, Taiwan
P: +886-4-2708-3393 F: +886-4-2708-3395

TAINAN Rm. A1, 9F., No.189, Sec. 1, Yongfu Rd., West Central Dist., Tainan City 700, Taiwan

P: +886-6-215-6058 F: +886-6-215-5518

India:

NSK BEARINGS INDIA PRIVATE LTD.

CHENNAI ☆ TVH Beliciaa Towers, 2nd Floor, Block I, No.71/1, MRC Nagar Main Road, MRC Nagar, Chennai, Tamil Nadu, India - 600028

P: +91-44-28479600

GURGAON Unit No. 202, 2nd Floor, 'A' Block, Iris Tech Park, Sector-48, Sohna Road, Gurgaon, Haryana, India-122018

P: +91-124-4838000

MUMBAI 91 Spring Board Business Hub Private Limited, Godrej & Boyce, Gate No 2, Plant No 6, LBS Marg, Opposite Vikhroli Bus Depot, Vikhroli West, Mumbai, Maharashtra 400079, India

P: +91-9987617968

JAMSHEDPUR 36, Maharani Mansion Ground Floor, Circuit House Area P.O.- Bistupur, East Singhbhum, Jamshehpur, Jharkhand, India-831011

P: +91-657-2421144

Indonesia:

PT. NSK INDONESIA

JAKARTA Summitmas II, 6th Floor, Jl. Jend Sudirman Kav. 61-62, Jakarta 12190, Indonesia
P: +62-21-252-3458 F: +62-21-252-3223

Korea:

NSK KOREA CO., LTD.

SEOUL Posco Center (West Wing) 9F, 440, Teheran-ro, Gangnam-gu, Seoul, 06194, Korea

P: +82-2-3287-0300 F: +82-2-3287-0345

Malaysia:

NSK BEARINGS (MALAYSIA) SDN. BHD.

SHAH ALAM ☆ No. 2, Jalan Pemaju, U1/15, Seksyen U1, Hicom Glenmarie Industrial Park, 40150 Shah Alam, Selangor, Malaysia

P: +60-3-7803-8859 F: +60-3-7806-5982

PRAI No.24, Jalan kikkik, Taman Inderawasih, 13600 Prai, Penang, Malaysia
P: +60-4-3902275 F: +60-4-3991830

JOHOR BAHRU 88 Jalan Ros Merah 2/17, Taman Johor Jaya, 81100 Johor Bahru, Johor, Malaysia
P: +60-7-3546290 F: +60-7-3546291

IPOH No.10&10A, Jalan Industri Paloh, Kawasan Perindustrian Ringan Paloh, 30200 Ipoh, Perak,Malaysia
P: +60-5-2555000 F: +60-5-2553373

Philippines:

NSK REPRESENTATIVE OFFICE

MANILA 8th Floor The Salcedo Towers 169 H.V. Dela Costa St.,Salcedo Villeg Makati City, Philippines 1227

P: +63-2-893-9543 F: +63-2-893-9173

Singapore:

NSK INTERNATIONAL (SINGAPORE) PTE LTD.

SINGAPORE 238A, Thomson Road, #24-01/05, Novena Square Tower A, Singapore 307684
P: +65-6496-8000 F: +65-6250-0247

Thailand:

NSK BEARINGS (THAILAND) CO.,LTD.

BANGKOK 26 Soi Onnuch 55/1 Pravet Subdistrict, Pravet District, Bangkok 10250, Thailand
P: +66-2320-2555 F: +66-2320-2826

Vietnam:

NSK VIETNAM CO., LTD.

HANOI ☆ Techno Center, Room 204-205, Thang Long Industrial Park, Dong Anh District, Hanoi, Vietnam

P: +84-24-3955-0159 F: +84-24-3955-0158

HO CHI MINH CITY Unit 609, The Landmark Building, 5B Ton Duc Thang Street,District 1, REPRESENTATIVE

Ho Chi Minh City, Vietnam

OFFICE P: +84-28-3822-7907 F: +84-28-3822-7910

Worldwide Sales Offices

P: Phone F: Fax ☆: Head Office

●Europe

United Kingdom:

NSK EUROPE LTD. (EUROPEAN HEADQUARTERS)

MAIDENHEAD Belmont Place, Belmont Road, Maidenhead, Berkshire SL6 6TB, U.K.
P: +44-1628-509-800 F: +44-1628-509-808

NSK UK LTD.

NEWARK Northern Road, Newark, Nottinghamshire NG24 2JF, U.K.

P: +44-1636-605-123 F: +44-1636-605-000

France:

NSK FRANCE S.A.S.

PARIS Quartier de l'Europe, 2 Rue Georges Guynemer, 78283 Guyancourt, France
P: +33-1-30-57-39-39 F: +33-1-30-57-00-01

Germany:

NSK DEUTSCHLAND GMBH

DUSSELDORF ☆ Harkortstrasse 15, D-40880 Ratingen, Germany
P: +49-2102-4810 F: +49-2102-4812-290

STUTTGART Liebknechtstrasse 33, D-70565 Stuttgart-Vaihingen, Germany

P: +49-711-79082-0 F: +49-711-79082-289

WOLFSBURG Tischlerstrasse 3, D-38440 Wolfsburg, Germany

P: +49-5361-27647-10 F: +49-5361-27647-70

Italy:

NSK ITALIA S.P.A.

MILANO Via Garibaldi 215, Garbagnate Milanese (Milano) 20024, Italy

P: +39-299-5191 F: +39-299-025778

Netherlands:

NSK EUROPEAN DISTRIBUTION CENTRE B.V.

TILBURG Brakman 54, 5047 SW Tilburg, Netherlands

P: +31-13-4647647 F: +31-13-4641082

Poland:

NSK POLSKA SP.Z O.O.

WARSAW Ul. Migdalowa 4/73, 02-796, Warsaw, Poland

P: +48-22-645-1525 F: +48-22-645-1529

Spain:

NSK SPAIN S.A.

BARCELONA C/Tarragona, 161 Cuerpo Bajo, 2a Planta, 08014, Barcelona, Spain

P: +34-93-289-2763 F: +34-93-433-5776

Turkey:

NSK RULMANLARI ORTA DOGU TIC. LTD. STI.

ISTANBUL Cevizli Mahallesi. D-100 Güney Yanyolu, Kuriş Kule İş Merkezi No:2 Kat:4, P.K.: 34846, Cevizli-Kartal-Istanbul, Turkey

P: +90-216-5000-675 F: +90-216-5000-676

United Arab Emirates:

NSK BEARINGS GULF TRADING CO.

DUBAI JAFZA View 19, Floor 24 Office LB192402/3, PO Box 262163, DOWNTOWN Jebel Ali, Dubai, U.A.E

P: +971-(0)4-804-8200 F: +971-(0)4-884-7227

●North and South America

United States of America:

NSK AMERICAS, INC. (AMERICAN HEADQUARTERS)

ANN ARBOR 4200 Goss Road, Ann Arbor, Michigan 48105, U.S.A.

P: +1-734-913-7500 F: +1-734-913-7511

NSK CORPORATION

ANN ARBOR 4200 Goss Road, Ann Arbor, Michigan 48105, U.S.A.

P: +1-734-913-7500 F: +1-734-913-7511

NSK PRECISION AMERICA, INC.

FRANKLIN ☆ 3450 Bearing Drive, Franklin, Indiana 46131, U.S.A.

P: +1-317-738-5000 F: +1-317-738-5050

SAN JOSE 780 Montague Expressway, Suite 505, San Jose, California, 95131, U.S.A.

P: +1-408-944-9400 F: +1-408-944-9405

NSK LATIN AMERICA, INC.

MIAMI 11601 NW 107 Street, Suite 200, Miami Florida, 33178, U.S.A.

P: +1-305-477-0605 F: +1-305-477-0377

Canada:

NSK CANADA INC.

TORONTO ☆ 317 Rutherford Road South, Brampton, Ontario, L6W 3R5, Canada

P: +1-888-603-7667 F: +1-905-890-1938

MONTREAL 2150-32E Avenue Lachine, Quebec, Canada H8T 3H7

P: +1-514-633-1220 F: +1-800-800-2788

Argentina:

NSK ARGENTINA SRL

BUENOS AIRES Garcia del Rio 2477 Piso 7 Oficina "A" (1429) Buenos Aires-Argentina

P: +54-11-4704-5100 F: +54-11-4704-0033

<As of July 2024>

For the latest information, please refer to the NSK website.

www.nsk.com

Every care has been taken to ensure the accuracy of data in this publication, but NSK Ltd. accepts no liability for any loss or damage incurred from errors or omissions. As we pursue continuous improvement, all content (text, images, product appearances, specifications, etc.) contained in this publication is subject to change without notice. Unauthorized copying and/or use of the contents of this publication is strictly prohibited. Please investigate and follow the latest product export laws, regulations, and permit procedures when exporting to other countries.

MOTION & CONTROL™
NSK



NSK used environmentally friendly paper and printing methods for this publication.