

NSK

MEGATORQUE® MOTOR SYSTEM

User's Manual

(ESA25 Driver Unit System)

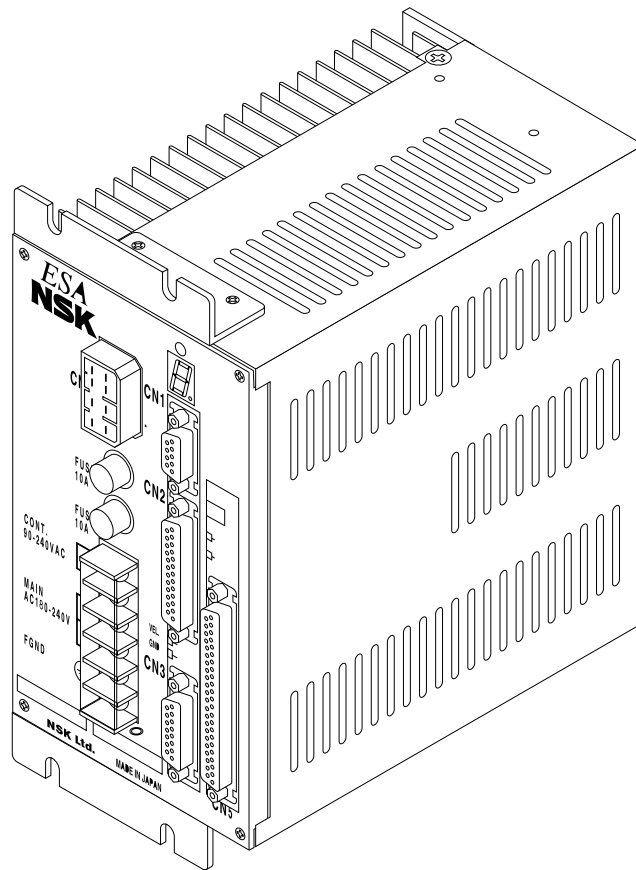

M-E099SA0C2-058

NSK Ltd.

Document Number: C20058-02

Limited Warranty

NSK Ltd. warrants its products to be free from defects in material and/or workmanship which NSK Ltd. is notified of in writing within, which comes first, one (1) year of shipment or 2400 total operation hours. NSK Ltd., at its option, and with transportation charges prepaid by the claimant, will repair or replace any product which has been proved to the satisfaction of NSK Ltd. to have a defect in material and/or workmanship.

This warranty is the sole and exclusive remedy available, and under no circumstances shall NSK Ltd. be liable for any consequential damages, loss of profits and/or personal injury as a result of claim arising under this limited warranty. NSK Ltd. makes no other warranty express or implied, and disclaims any warranties for fitness for a particular purpose or merchantability.

Copyright 1997-2000 by NSK Ltd., Tokyo, Japan

All rights reserved.

No part of this publication may be reproduced in any form or by any means without permission in writing from NSK Ltd.

NSK Ltd. reserves the right to make changes to any products herein to improve reliability, function or design without prior notice and without any obligation.

NSK Ltd. does not assume any liability arising out of the application or use of any product described herein; neither does it convey any licence under its present patent nor the rights of others.

Patents issued and patents pending.

“MEGATORQUE” is a registered trademark of NSK Ltd. in Japan and that of NSK Corp. in the United States of America.

Contents

1. Notes to Users -----	1-1	4. Connector Specification -----	4-1
1.1. About This Manual -----	1-1	4.1. CN1: RS-232C Serial Communication Connector --	4-1
1.2. Notes for Safety -----	1-1	4.1.1. CN1 Pin-Out -----	4-1
1.3. Operational Remarks -----	1-2	4.1.2. CN1 Signal List -----	4-1
2. System Outline -----	2-1	4.1.3. Sample Wiring Diagram -----	4-2
2.1. System Configuration -----	2-1	4.2. CN2,CN5: Control I/O Signal Connectors -----	4-3
2.2. Reference Number Configuration -----	2-2	4.2.1. Pin- Out (CN2, CN5) -----	4-3
2.2.1. Motor -----	2-2	4.2.2. Signal Name and Function (CN2, CN5) -----	4-4
2.2.2. Driver Unit -----	2-2	4.2.3. Setting the Polarity (A or B contact)	
2.2.3. Cable Set -----	2-2	of the Input Ports -----	4-6
2.2.4. Handy Terminal -----	2-2	4.2.4. Signal Specification -----	4-8
2.3. Standard Combination -----	2-3	4.2.4.1. General Input -----	4-8
2.3.1. YS Series Motor -----	2-3	4.2.4.2. Pulse Train Input -----	4-8
2.3.1.1. Motor and Driver Unit -----	2-3	4.2.4.3. General Output -----	4-8
2.3.1.2. Cable Set -----	2-3	4.2.4.4. Alarm Output -----	4-9
2.3.2. JS Series Motor -----	2-4	4.2.4.5. Position Feed Back -----	4-9
2.3.2.1. Motor and Driver Unit -----	2-4	4.2.4.6. Analog Command Input -----	4-10
2.3.2.2. Cable Set -----	2-4	4.2.4.7. Analog Monitor Output -----	4-10
3. Specification -----	3-1	4.2.5. Wiring Example (CN2, CN5) -----	4-11
3.1. Motor Specification -----	3-1	4.2.5.1. Position Control Mode Wiring Example -	4-11
3.1.1. YS Series Motor -----	3-1	4.2.5.2. Wiring Example of Velocity Control/	
3.1.1.1. Name of Parts -----	3-1	Torque Control Mode -----	4-12
3.1.1.2. Specification -----	3-2	4.2.5.3. Wiring Example of YS Series Motor with	
3.1.1.3. Dimensions -----	3-5	Brake -----	4-13
3.1.2. JS Series Motor -----	3-11	4.3. CN3: Resolver Cable Connector -----	4-16
3.1.2.1. Name of Parts -----	3-11	4.3.1. CN3 Pin-out -----	4-16
3.1.2.2. Specification -----	3-11	4.3.2. CN3 Signal List -----	4-16
3.1.2.3. Dimensions -----	3-13	4.4. CN4: Motor Cable Connector -----	4-17
3.2. Driver Unit -----	3-15	4.4.1. CN4 Pin-out -----	4-17
3.2.1. Name of Parts -----	3-15	4.4.2. CN4 Signal List -----	4-17
3.2.2. General Specification -----	3-16	4.5. TB: Terminal Block for Power Supply -----	4-18
3.2.3. Functional Specification -----	3-17	4.5.1. Terminal List -----	4-18
3.2.4. Jumper -----	3-19	4.5.2. Wiring Diagram (TB) -----	4-18
3.2.5. Dimensions -----	3-20		
3.3. Cable Set -----	3-21		
3.3.1. Cable Set for YS Motor -----	3-21		
3.3.2. Cable Set for YS Motor with Brake -----	3-21		
3.3.3. Cable Set for JS Motor -----	3-22		
3.4. Handy Terminal -----	3-23		
3.4.1. Name of Parts and Dimensions -----	3-23		
3.4.2. Specification -----	3-24		

5. Unpacking, Installing, Wiring -----	5-1	8. Operational Function -----	8-1
5.1. Unpacking and Inspection -----	5-1	8.1. General Operation and Function -----	8-1
5.1.1. Unpacking -----	5-1	8.1.1. Servo "ON" -----	8-1
5.1.2. Motor and Driver Unit Combination -----	5-2	8.1.2. Emergency Stop -----	8-2
5.2. Installation -----	5-3	8.1.3. Clearing Position Error Counter -----	8-3
5.2.1. Motor -----	5-3	8.1.4. Integration off (IOFF) -----	8-3
5.2.1.1. Motor Mounting -----	5-3	8.1.5. Overtravel Limit Switch -----	8-4
5.2.1.2. Load Inertia -----	5-4	8.1.5.1. Hardware Overtravel Limit Switch -----	8-4
5.2.2. Driver Unit Mounting -----	5-5	8.1.5.2. Software Overtravel Limit Switch -----	8-5
5.3. Wiring -----	5-6	8.1.6. Alarm Output -----	8-6
5.3.1. Connecting Motor and Driver Unit -----	5-6	8.1.7. Brake Signal Output -----	8-6
5.3.2. Connecting Power -----	5-7	8.1.8. In-Position Output -----	8-7
5.3.3. Connector Wiring -----	5-8	8.1.8.1. Output Signal Format -----	8-8
5.3.4. Ground Connection and Wiring -----	5-8	8.1.8.2. Parameter "IN" -----	8-9
5.4. Turning on Power -----	5-9	8.1.8.3. Parameter "IS" -----	8-9
5.4.1. Precautions -----	5-9	8.1.8.4. "IPOS" Output in Special Occasion. -	8-10
5.4.2. Turning Power on -----	5-9	8.1.9. Position Feedback Signal -----	8-11
5.4.3. Servo On -----	5-10	8.1.10. Monitor Functions -----	8-12
6. Handy Terminal Communication -----	6-1	8.1.10.1. Velocity Monitor -----	8-13
6.1. When Power is Turned on -----	6-1	8.1.10.2. Monitoring I/O State (IO) -----	8-14
6.2. Command Entry -----	6-2	8.1.10.3. Reading Current Position -----	8-17
6.2.1. Password -----	6-2	8.1.10.4. Analog Monitor -----	8-18
6.2.2. Canceling Command -----	6-3	8.2. For More Advanced Operation -----	8-20
6.2.3. Error -----	6-3	8.2.1. Position Scale -----	8-20
6.2.4. Entering Parameter -----	6-4	8.2.1.1. Resolution -----	8-20
6.2.5. Entering Parameter Requiring Entry of		8.2.1.2. Direction of Position Scale -----	8-20
Password -----	6-4	8.2.1.3. Types of Position Scale -----	8-21
6.3. Readout Command -----	6-5	8.2.1.4. Position Scale Reset -----	8-24
6.3.1. "TS" Command for Reading Set Value -----	6-5	8.2.1.5. Example of Position Scale Setting --	8-24
6.3.2. " ? " Reading Function Command		8.2.2. Digital Filter -----	8-25
for Set Value -----	6-6	8.2.3. Feed Forward Compensation -----	8-26
7. Tuning and Trial Running -----	7-1	8.2.4. Integrator Limit : ILV -----	8-26
7.1. Tuning Sequence -----	7-1	8.2.5. Dead Band Setting: DBP -----	8-27
7.2. Automatic Tuning -----	7-2	8.3. RS-232C Communication -----	8-28
7.2.1. Precautions -----	7-2	8.3.1. Specification of Communication -----	8-28
7.2.2. Initialize Servo Parameters -----	7-4	8.3.2. Communication Procedure -----	8-28
7.2.3. Execution of Automatic Tuning		8.3.2.1. When Power is Turned on -----	8-28
(Tuning Level 1) -----	7-5	8.3.2.2. Command Entry -----	8-29
7.2.4. Trial Running (Tuning Level 1) -----	7-6	8.3.2.3. Password -----	8-30
7.2.5. Servo Gain Minor Adjustment		8.3.2.4. Canceling Command -----	8-31
(Tuning Level 2) -----	7-8	8.3.2.5. Error -----	8-32
7.3. Manual Tuning -----	7-10	8.3.2.6. Readout Command -----	8-33
7.3.1. Precautions -----	7-10	8.3.3. Daisy Chain Communication -----	8-35
7.3.2. Adjustment of the Velocity Gain (VG) -----	7-10	8.3.3.1. Procedure to Set Daisy chain	
7.3.3. Adjustment of Velocity Integrator Frequency		Communication -----	8-35
(VI) -----	7-12	8.3.3.2. Initial Setting -----	8-36
7.4. Setting Filters (Tuning Level 2) -----	7-14	8.3.3.3. Interfacing -----	8-36
		8.3.3.4. Power on -----	8-38
		8.3.3.5. Operation -----	8-39

9. Operation -----	9-1	13. Alarm -----	13-1
9.1. Preparation -----	9-1	13.1. Identifying Alarm -----	13-1
9.1.1. Wiring Check -----	9-1	13.1.1. LED Alarm Indicator -----	13-1
9.1.2. Procedure -----	9-1	13.1.2. Using TA Command -----	13-2
9.2. Position Control Mode Operation -----	9-2	13.1.3. Alarm Code List -----	13-3
9.2.1. Home Return -----	9-2	13.2. Details of Alarm -----	13-4
9.2.1.1. Home Return Parameter List -----	9-4	13.2.1. Normal State -----	13-4
9.2.1.2. Adjusting Home Position Switch and Home Offset Value -----	9-4	13.2.2. Alarms Related to Power Amplifier -----	13-4
9.2.2. Programmable Indexer -----	9-7	13.2.2.1. Heat Sink Overheat or Regeneration Resistor Overheat -----	13-4
9.2.2.1. Programmable Indexer Channel Switching -----	9-8	13.2.2.2. Abnormal Main AC Line Voltage ----	13-5
9.2.3. Pulse Train Command Operation -----	9-9	13.2.2.3. Over Current -----	13-6
9.2.3.1. Pulse Train Signal Format -----	9-9	13.2.2.4. Control AC Line Under-Voltage ----	13-6
9.2.3.2. Pulse Train Resolution -----	9-10	13.2.3. Alarms Related to Motor -----	13-7
9.2.3.3. Input Timing -----	9-13	13.2.3.1. Resolver Circuit Error -----	13-7
9.2.4. RS-232C Position Commands -----	9-14	13.2.3.2. Software Thermal Sensor -----	13-8
9.2.5. Jog Operation -----	9-15	13.2.4. Alarms Related to Control -----	13-8
9.3. Velocity Control Mode Operation -----	9-16	13.2.4.1. Memory Error -----	13-8
9.3.1. RS-232C Communication Command -----	9-16	13.2.4.3. CPU Error -----	13-9
9.3.2. Analog Velocity Command -----	9-17	13.2.4.4. Interface Error -----	13-9
9.4. Torque Control Mode Operation -----	9-19	13.2.4.5. Analog Command Error -----	13-10
9.4.1. RS-232C Communication Command -----	9-19	13.2.4.6. Excess Position Error -----	13-10
9.4.2. Analog Torque Command -----	9-20	13.2.4.7. Software Over Travel Limit -----	13-11
10. Programming -----	10-1	13.2.4.8. Hardware Over Travel Limit -----	13-11
10.1. Commands and Parameters -----	10-2	13.2.4.9. Emergency Stop -----	13-11
10.2. Program Editing Command -----	10-4	13.2.4.10. Program Error -----	13-12
10.3. Inputting a Program -----	10-5	13.2.4.11. Automatic Tuning Error -----	13-12
10.4. Sample Program -----	10-7	14. Troubleshooting -----	14-1
11. Command and Parameter -----	11-1	14.1. Identifying Problem -----	14-1
11.1. List of Command and Parameter -----	11-1	14.2. Troubleshooting -----	14-2
11.2. Glossary -----	11-5	14.2.1. Power Trouble -----	14-3
12. Maintenance -----	12-1	14.2.2. Motor Trouble -----	14-4
12.1. Precautions -----	12-1	14.2.3. Command Trouble -----	14-6
12.2. Maintenance Check -----	12-2	14.2.4. Terminal Trouble -----	14-10
12.2.1. Motor -----	12-2	Appendix	
12.2.2. Driver Unit and Cable Set -----	12-2	Appendix 1: How to Check Motor Condition -----	A-1
12.3. Periodical Replacement of Parts -----	12-3	Appendix 2: Initializing Driver Unit -----	A-5
12.3.1. Motor -----	12-3	Appendix 3: How to Replace ESA25 Driver Unit -----	A-7
12.3.2. Driver Unit -----	12-3	Appendix 4: Regenerative Dump Resistor -----	A-14
12.4. Storing -----	12-3	Appendix 5: Brake Built in YS Series Motor -----	A-16
12.5. Limited Warranty -----	12-3	Appendix 6: Parameter · Program Setting List -----	A-20

(Blank Page)

1. Notes to Users

1.1. About This Manual

- This manual describes the interface, function, and operation of the Megatorque Motor System with the ESA25 Driver Unit.
- Before operating the Megatorque Motor System for the first time, this manual should be read thoroughly.
- Motors, Driver Units and Cable sets described in this manual are interchangeable.
- For motors, this manual describes the standard Motor of YS and JS series only.
If your motor is not one of these, please refer to the respective specification document to which the priority is given.

1.2. Notes for Safety

- Following notice is added to the clause of safety precautions to get your attention.
 - Danger** : Might cause serious injuries
 - Warning** : Might result in injuries
 - Caution** : Might damage the equipment (machine) and/or the load attached to the motor (work or end effector), or might cause malfunction of the system.

1.3. Operational Remarks

- Pay special attention to the following precautions when installing, adjusting, checking and troubleshooting Megatorque Motor System.

Caution : *Make sure that Motor size and maximum torque number of Motor and Driver Unit are the same. Refer to “2.3. Standard Combination” for the details.*

- *Parameters of Driver Unit are set to Motor size and maximum torque before shipped.*
- *If the numbers are different, the system does not operate properly.*

Caution : *Do not make Cable Set shorter or longer. Changing the length may worsen Motor and Driver Unit performance.*

Caution : *Do not disassemble the Motor since it is precisely adjusted and assembled. If disassembled, it may cause abnormalities such as deterioration in accuracy and rigidity as well as noise.*

Caution : *Do not touch Driver Unit. Touching the Driver Unit just after the power is turned off may cause electric shock.*

- *Driver Unit has high capacity conductors in its internal circuits and there is high residual voltage for few minutes after the power is turned off.*
- *Do not detach Driver Unit cover unless it is necessary. When the cover has to be removed, follow procedures described below.*

- ① *Turn off the control and main power. If only main power has been turned on, turn the control power on for more than 5 seconds, then turn off both powers.*

Neglecting this procedure is very dangerous. The procedure is to reduce residual voltage of capacitors.

- ② *Wait for 5 minutes or more, then remove the cover.*

Figure 1-1

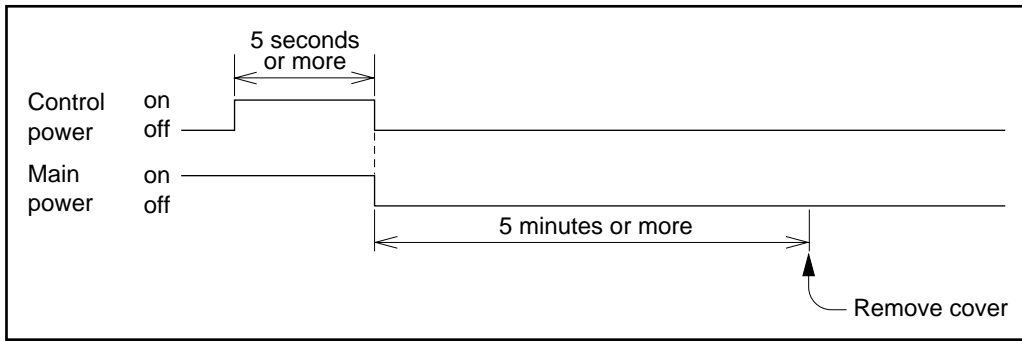

Caution : Using an optional regenerative dump resistor shall be considered for heavy duty operation .

- When Motor is decelerating, rotational energy is dissipated by internal dump resistor. Excessive rotational energy causes very high regeneration of Motor, the dump resistor is overheated, then the alarms goes off and Motor stops.
- Gentler deceleration rate or decreasing duty cycle prevents overheating of the dump resistor.
- If heavy duty operation is still needed, installation of optional “Regenerative Dump Resistor” is recommended. Refer to “Appendix 4” for the details.

Danger : Never apply any water or oil to Driver Unit. Take appropriate measures to protect Driver Unit from water, oil, slag , dust and corrosive gas.

Warning : Do not conduct an “Isolation test” or “Megger test” on Driver Unit. It may damage the internal circuit.

Caution : Be sure to adjust the servo parameters according to conditions of actual use. In most cases, the Direct Drive Motor System cannot exhibit its full performance unless the shipping set of these parameters are not altered. Refer to “7. Tuning and Trial Running” for the details of parameter setting.

(Blank Page)

2. System Outline

2.1. System Configuration

Figure 2-1: System configuration (without brake)

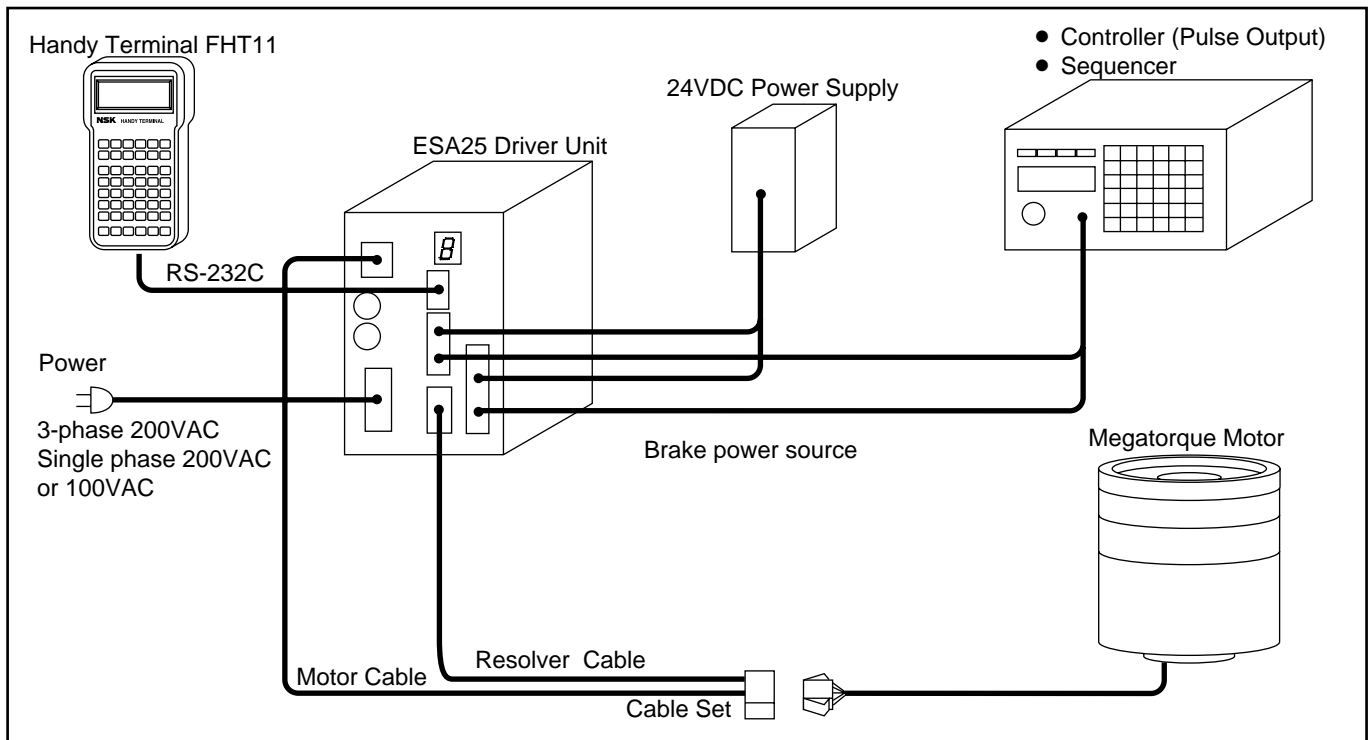
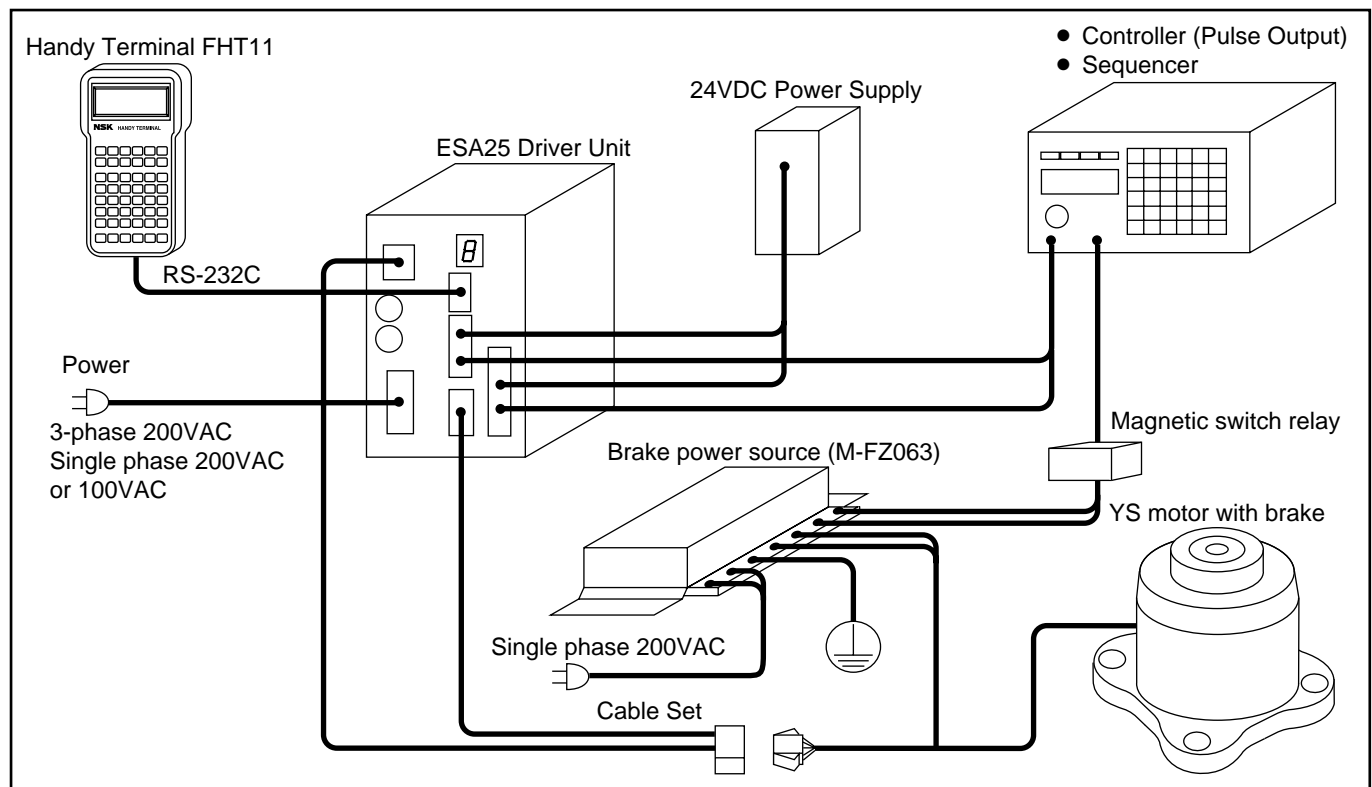

Figure 2-2: System configuration with brake



2.2. Reference Number Configuration

2.2.1. Motor

Figure 2-3

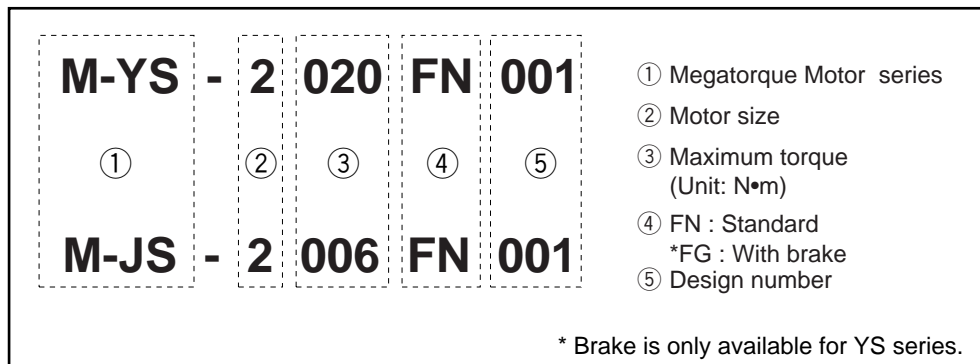

2.2.2. Driver Unit

Figure 2-4

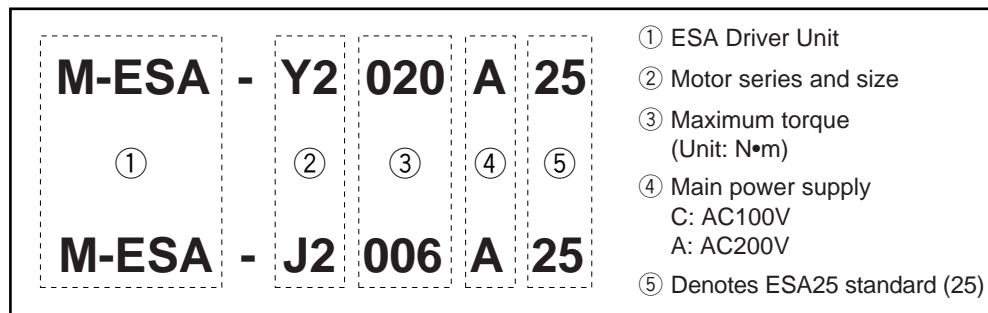

2.2.3. Cable Set

Figure 2-5

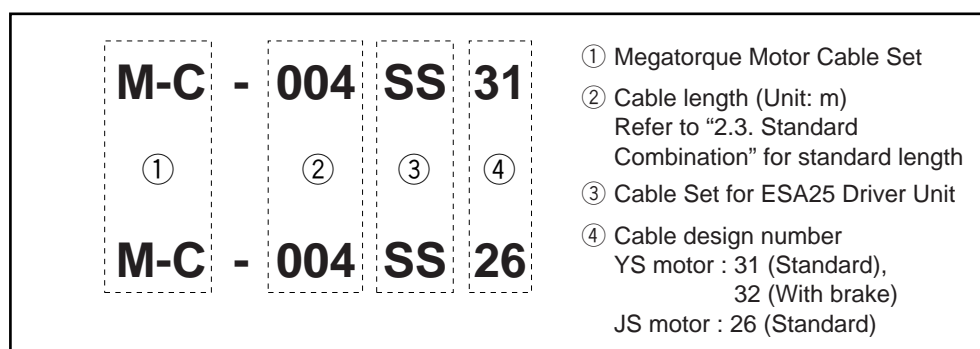

2.2.4. Handy Terminal

Figure 2-6

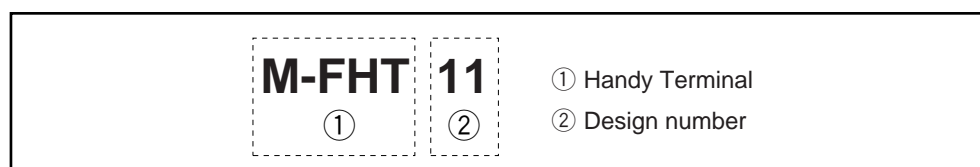

2.3. Standard Combination

- This section describes “Standard Combination” of the Motor, ESA25 Driver Unit and Cable set.
- Make sure to select right combination of each parts when ordering.

2.3.1. YS Series Motor

2.3.1.1. Motor and Driver Unit

Table 2-1

Motor Reference No.	ESA25 Driver Unit Reference No.	Power Supply Voltage
M-YS2005FN001	M-ESA-Y2005C25	AC100V
	M-ESA-Y2005A25	AC200V
M-YS2020FN001	M-ESA-Y2020C25	AC100V
	M-ESA-Y2020A25	AC200V
M-YS3008FN001	M-ESA-Y3008C25	AC100V
	M-ESA-Y3008A25	AC200V
M-YS3040FN501	M-ESA-Y3040C25	AC100V
	M-ESA-Y3040A25	AC200V
M-YS4080FN001	M-ESA-Y4080C25	AC100V
	M-ESA-Y4080A25	AC200V
M-YS5120FN001	M-ESA-Y5120C25	AC100V
	M-ESA-Y5120A25	AC200V
M-YS5240FN001	M-ESA-Y5240A25	AC200V

2.3.1.2. Cable Set

Table 2-2: Standard

Reference No.	Length
M-C002SS31	2m
M-C004SS31	4m
M-C008SS31	8m
M-C015SS31	15m
M-C030SS31	30m

Table 2-3: Motor with brake

Reference No.	Length
M-C002SS32	2m
M-C004SS32	4m
M-C008SS32	8m
M-C015SS32	15m
M-C030SS32	30m

2.3.2. JS Series Motor

2.3.2.1. Motor and Driver Unit

Table 2-4

Motor Reference No.	ESA25 Driver Unit Reference No.	Power Supply Voltage
M-JS0002FN001	M-ESA-J0002C25	AC100V
	M-ESA-J0002A25	AC200V
M-JS1003FN001	M-ESA-J1003C25	AC100V
	M-ESA-J1003A25	AC200V
M-JS2006FN001	M-ESA-J2006C25	AC100V
	M-ESA-J2006A25	AC200V
M-JS2014FN001	M-ESA-J2014C25	AC100V
	M-ESA-J2014A25	AC200V

2.3.2.2. Cable Set

Table 2-5

Reference No.	Length
M-C002SS26	2m
M-C004SS26	4m
M-C008SS26	8m
M-C015SS26	15m
M-C030SS26	30m

3. Specification

3.1. Motor Specification

3.1.1. YS Series Motor

3.1.1.1. Name of Parts

Figure 3-1

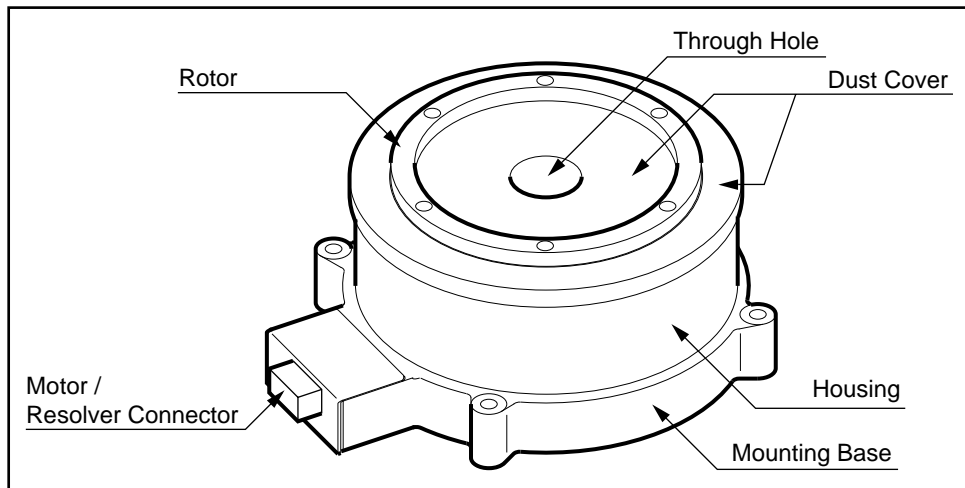

3.1.1.2. Specification

- There are three types of motor in YS series.
 - (1) Standard
 - (2) Motor with brake
 - (3) Low profile type
- YS Series Motor can be run on either 100V/110V or 200V/220V AC.
- The unit is in SI unit system
 - 1N = 0.102 kgf = 0.225lb
 - 1N · m = 0.102 kgf · m = 0.738 ft · lb

(1) Standard

Table 3.1: Standard

Motor reference No.		M-YS2020FN001	M-YS3040FN501	M-YS4080FN001	M-YS5120FN001	M-YS5240FN001
Item (Unit)						
Maximum torque	(N·m)	20	40	80	120	240
Maximum current/phase	(A)	6				
Allowable axial load	(N)	3700	4500	9500	19600	19600
Allowable moment load	(N·m)	60	80	160	400	400
Axial rigidity	(mm/N)	4.0×10^{-6}	3.0×10^{-6}	1.4×10^{-6}	1.0×10^{-6}	1.0×10^{-6}
Moment rigidity *1	(rad/N·m)	3.5×10^{-6}	2.5×10^{-6}	1.5×10^{-6}	3.0×10^{-7}	3.0×10^{-7}
Maximum stall torque	(N·m)	15	35	70	105	198
Rotor moment of inertia	(kg·m ²)	0.0070	0.020	0.065	0.212	0.255
Rotor inertia GD ²	(kgf·m ²)	0.028	0.080	0.26	0.85	1.020
Mass	(kg)	10	16	29	55	95
Operating condition		Temperature: 0~40°C, Humidity: 20~80 % , Use indoors in a dust-free condition.				
Maximum speed	(s ⁻¹ (r.p.s.))	3				
Resolver resolution	(p/rev)	614400				
Positioning accuracy	(sec)	150				
Repeatability	(sec)	±2.1				
Compatible Driver Unit	AC 200V	M-ESA-Y2020A25	M-ESA-Y3040A25	M-ESA-Y4080A25	M-ESA-Y5120A25	M-ESA-Y5240A25
	AC 100V	M-ESA-Y2020C25	M-ESA-Y3040C25	M-ESA-Y4080C25	M-ESA-Y5120C25	-

*1 These value assume that the Motor is mounted on a rigid base.

(1) Motor with brake

Table 3-2: Motor with brake

Motor reference No.		M-YS2020FG001	M-YS3040FG001	M-YS4080FG001	M-YS5120FG001
Item (Unit)					
Maximum torque	(N·m)	20	40	80	120
Maximum current/phase		6			
Allowable axial load	(N)	3700	4500	9500	19600
Allowable moment load	(N·m)	60	80	160	400
Axial rigidity	(mm/N)	4.0×10^{-6}	3.0×10^{-6}	1.4×10^{-6}	1.0×10^{-6}
Moment rigidity ^{*1}	(rad/N·m)	3.5×10^{-6}	2.5×10^{-6}	1.5×10^{-6}	3.0×10^{-7}
Maximum stall torque	(N·m)	15	35	70	105
Rotor moment of inertia	(kg·m ²)	0.008	0.023	0.072	0.240
Rotor inertia GD ²	(kgf·m ²)	0.032	0.092	0.288	0.96
Brake torque	(N·m)	20	40	80	120
Mass	(kg)	12	20	36	66
Operating condition		Temperature: 0~40°C, Humidity: 20~80 % , Use indoors in a dust-free condition.			
Maximum speed	(s ⁻¹ (rps))	3			
Resolver resolution	(p/rev)	614400			
Positioning accuracy	(sec)	150			
Repeatability	(sec)	± 2.1			
Compatible Driver Unit	AC 200V	M-ESA-Y2020A25	M-ESA-Y3040A25	M-ESA-Y4080A25	M-ESA-Y5120A25
	AC 100V	M-ESA-Y2020C25	M-ESA-Y3040C25	M-ESA-Y4080C25	M-ESA-Y5120C25

*1 These value assume that the Motor is mounted on a rigid base.

(1) Low profile type

Table 3-3: YS low profile type

Motor reference No.		M-YS2005FN001	M-YS3008FN001
Item (Unit)			
Maximum torque	(N·m)	5	8
Maximum current/phase	(A)	1.5	
Allowable axial load	(N)	3700	4500
Allowable moment load	(N·m)	60	80
Axial rigidity	(mm/N)	4.0×10^{-6}	3.0×10^{-6}
Moment rigidity ^{*1}	(rad/N·m)	3.5×10^{-6}	2.5×10^{-6}
Maximum stall torque	(N·m)	4	5
Rotor moment of inertia	(kg·m ²)	0.003	0.006
Rotor inertia GD ²	(kgf·m ²)	0.012	0.024
Mass	(kg)	4	6
Operating condition		Temperature: 0~40°C, Humidity: 20~80 % , Use indoors in a dust-free condition.	
Maximum speed	(s ⁻¹ (rps))	3	2/3 ^{*2}
Resolver resolution	(p/rev)	614400	
Positioning accuracy	(sec)	150	
Repeatability	(sec)	± 2.1	
Compatible Driver Unit	AC 200V	M-ESA-Y2005A25	M-ESA-Y2005A25
	AC 100V	M-ESA-Y2005C25	M-ESA-Y3008C25

*1 These value assume that the Motor is mounted on a rigid base.

*2 Differs with main power voltage.

● **How to calculate axial and moment load**

Caution : ● Do not apply excessive load to the Motor.
An excessive load more than specified in Table 3-2 may result in premature Motor failure.

- Followings show how to calculate the loads.

Figure 3-2: How to calculate loads

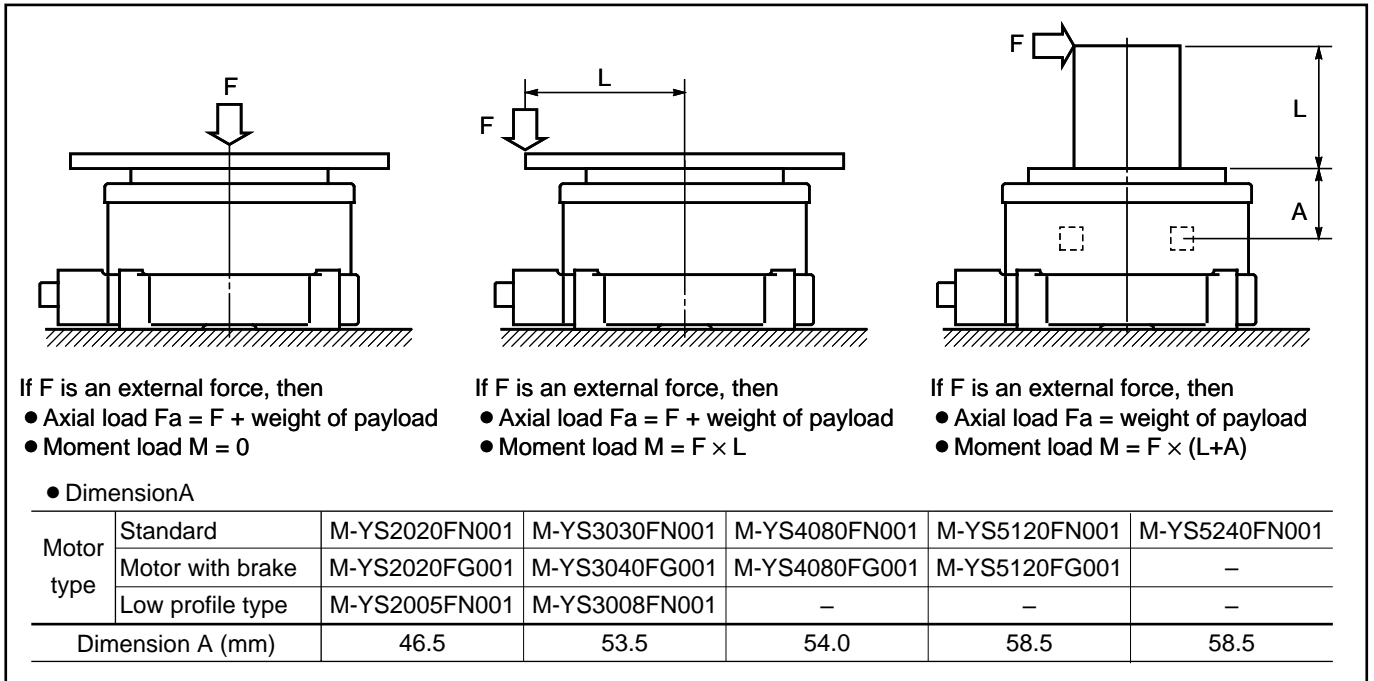

3.1.1.3. Dimensions

(1) Standard

Figure 3-3: M-YS2020FN001

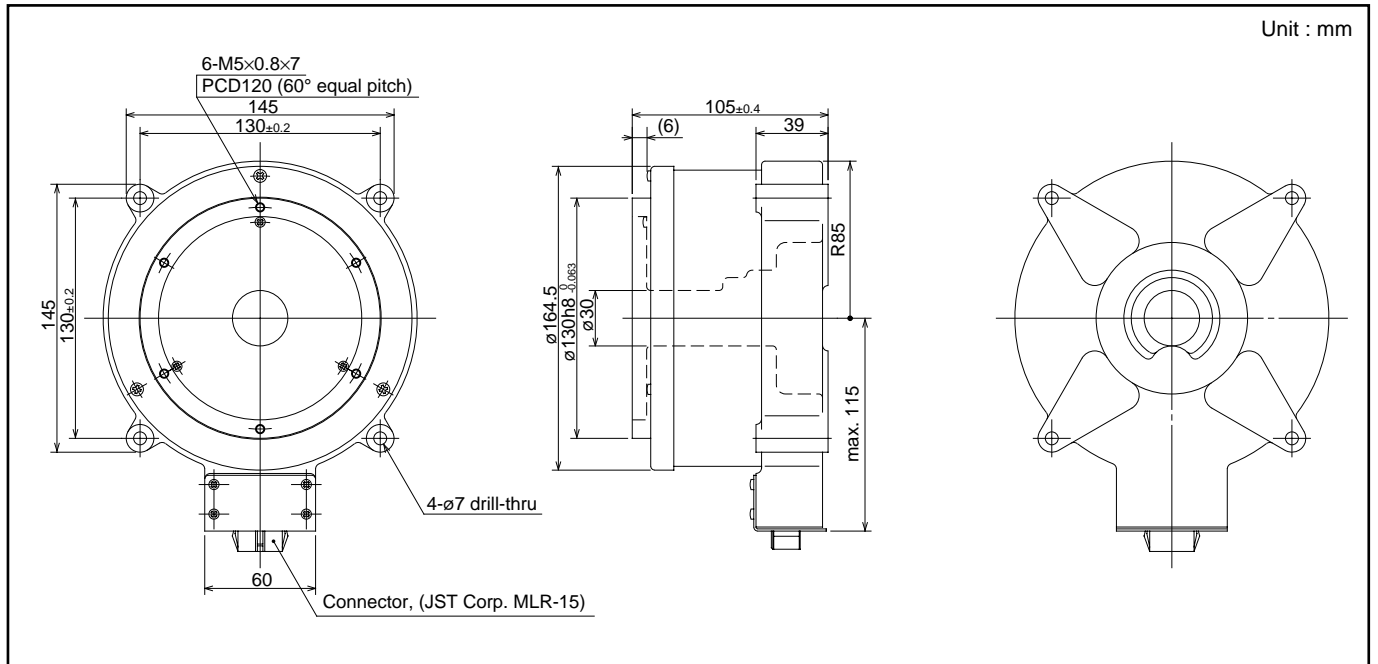

Figure 3-4: M-YS3040FN501

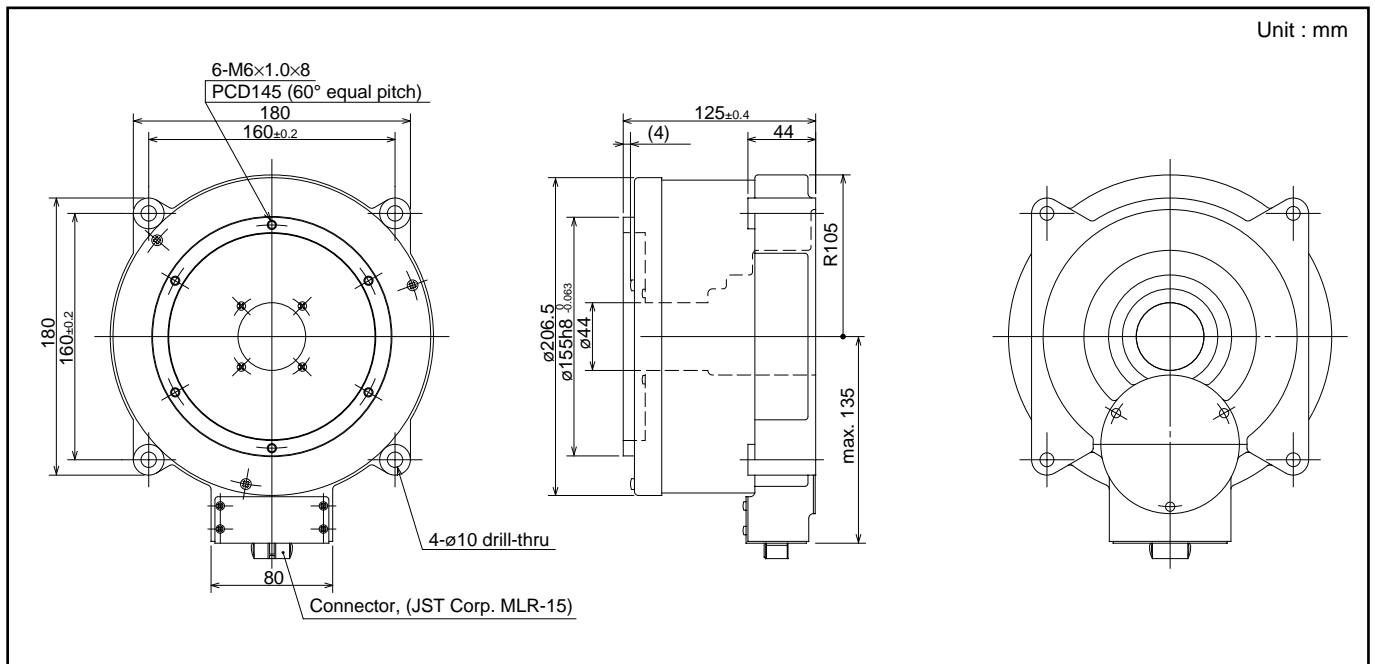

Figure 3-5: M-YS4080FN001

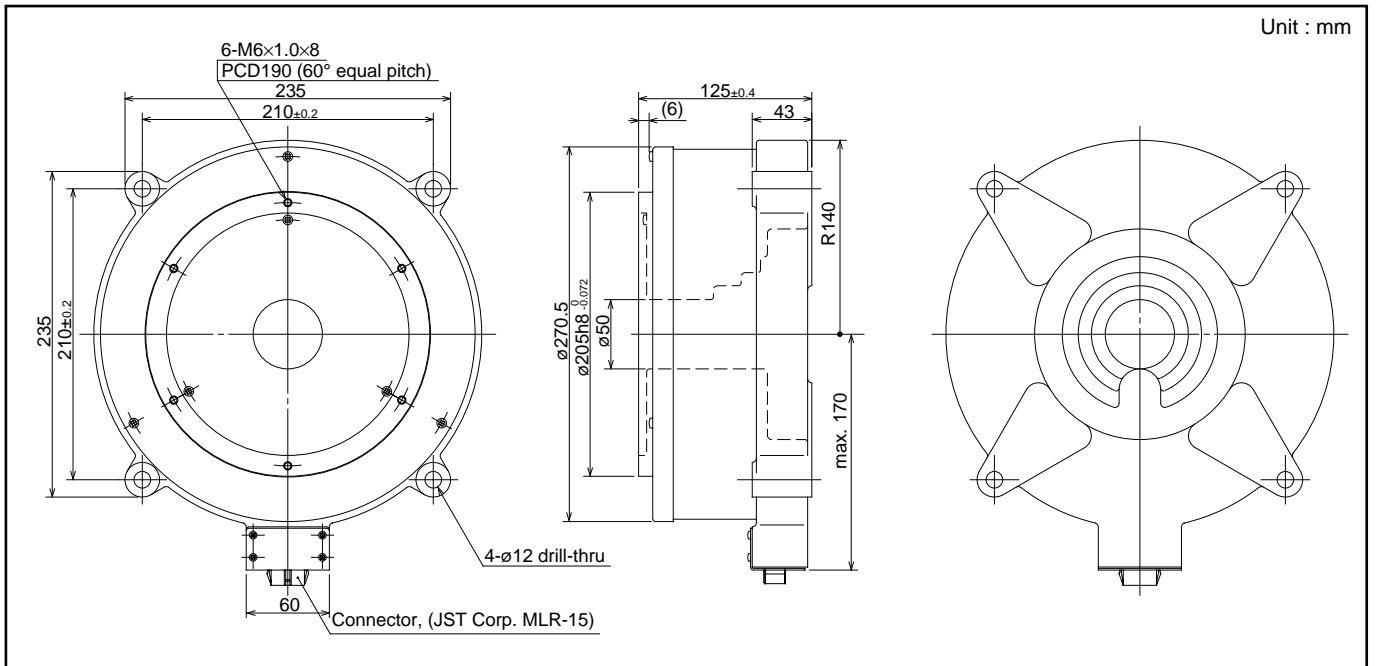

Figure 3-6: M-YS5120FN001

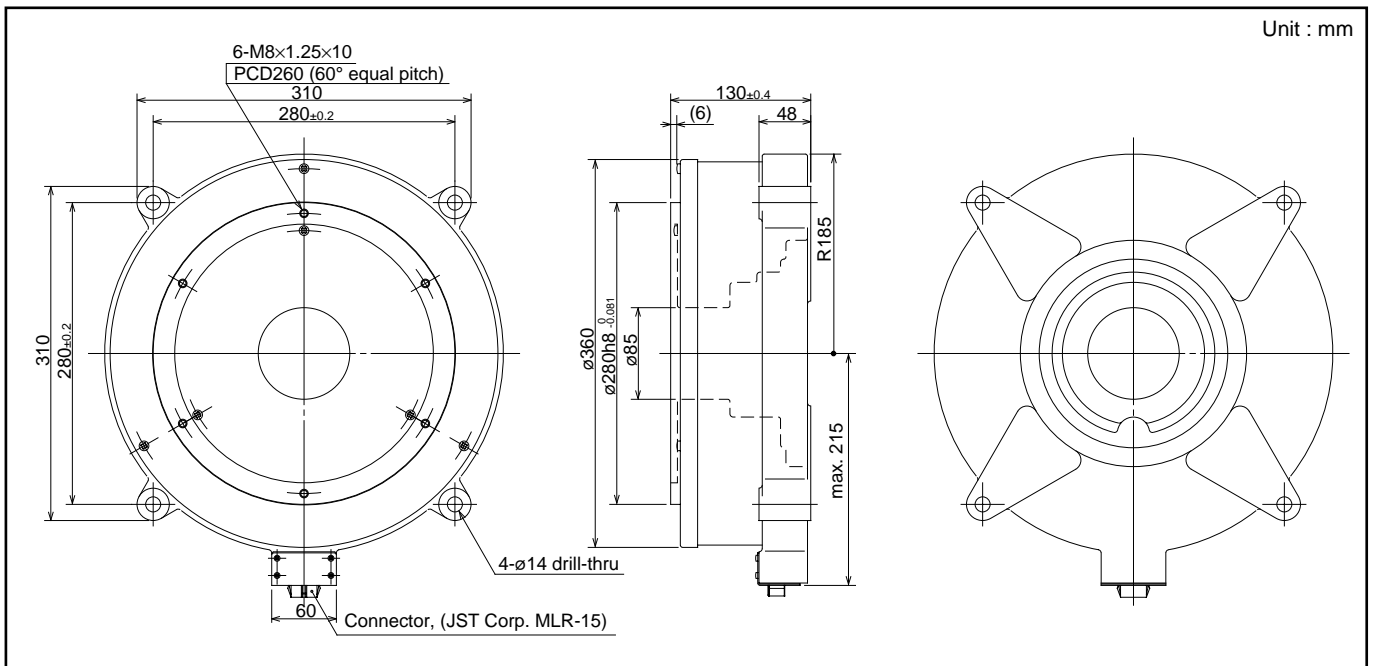
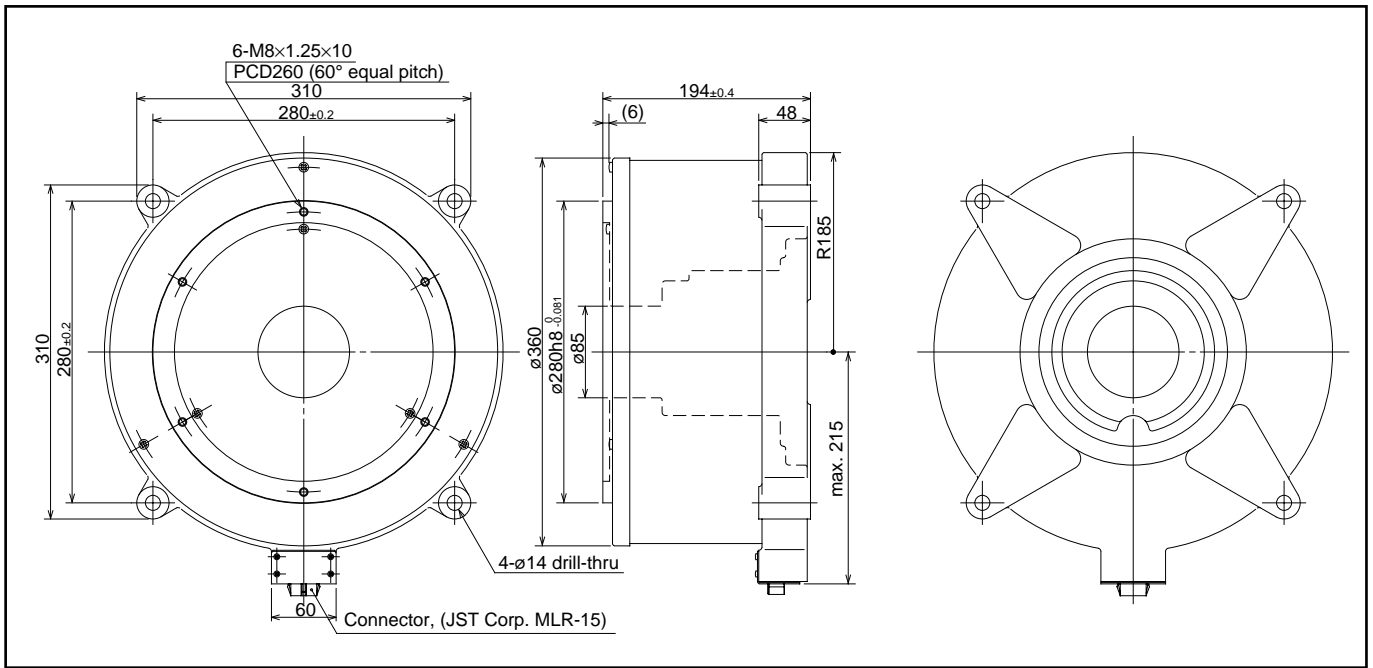

Figure 3-7: M-YS5240FN001



(2) Motor with brake

Figure 3-8: M-YS2020FG001

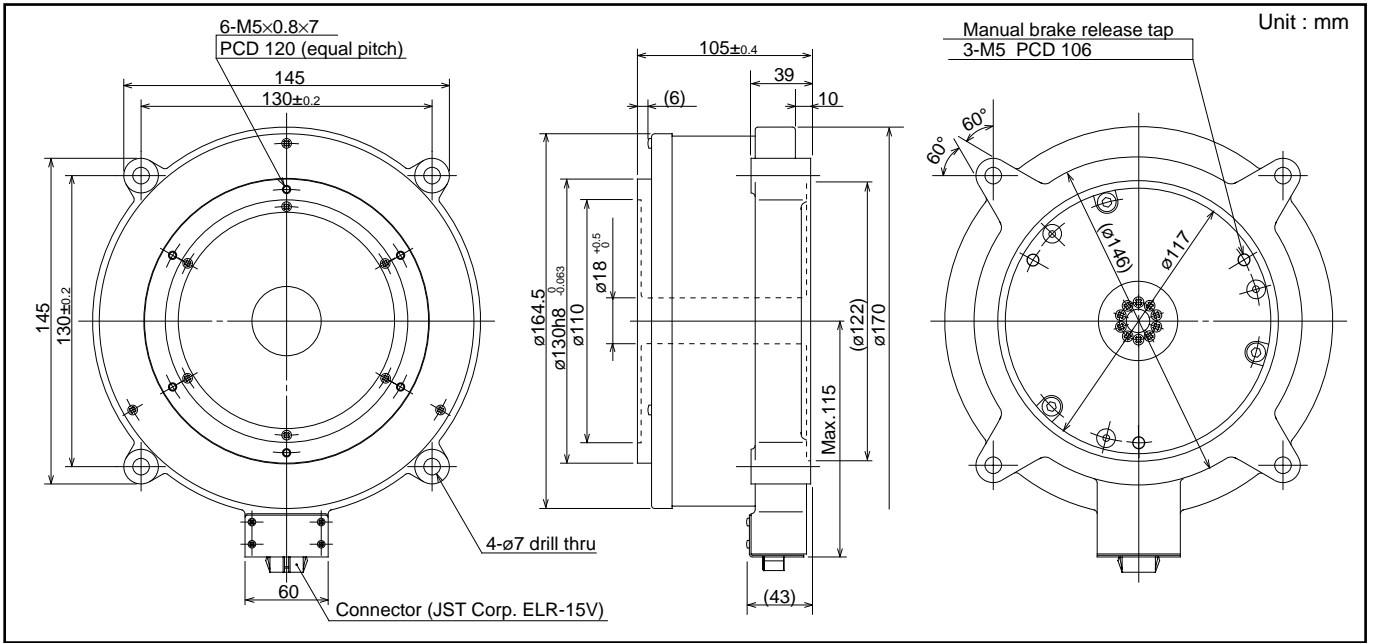

Figure 3-9: M-YS3040FG001

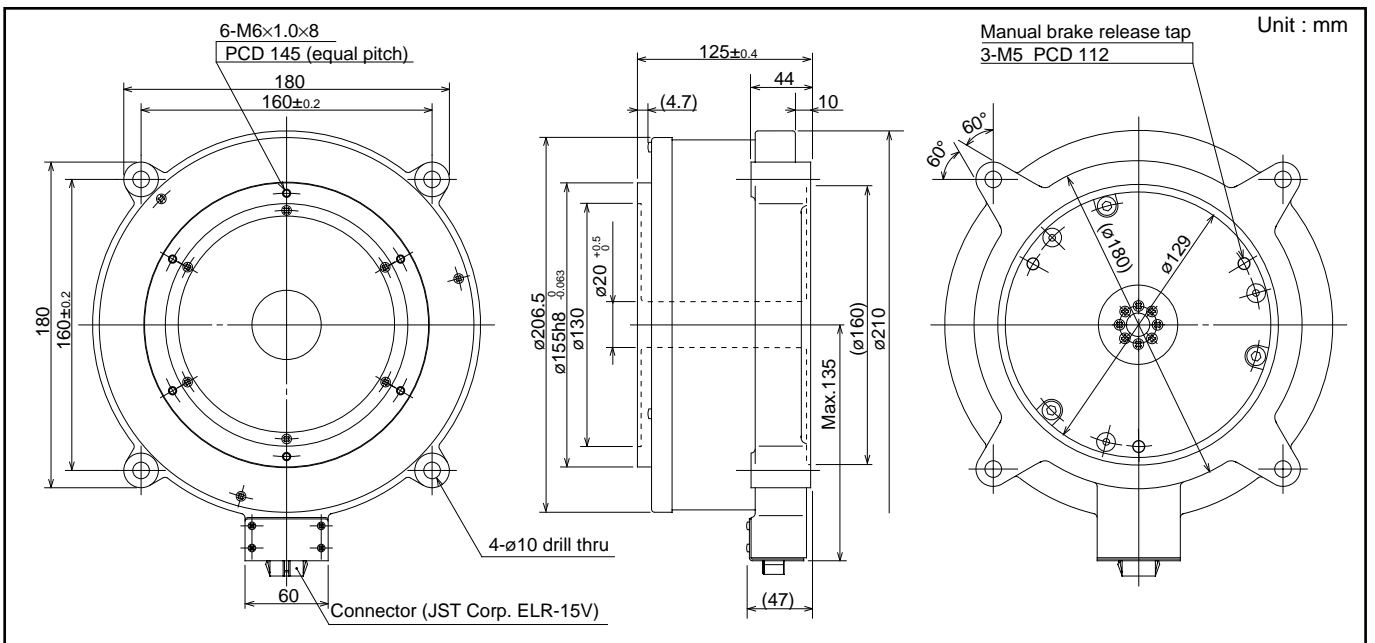

Figure 3-10: M-YS4080FG001

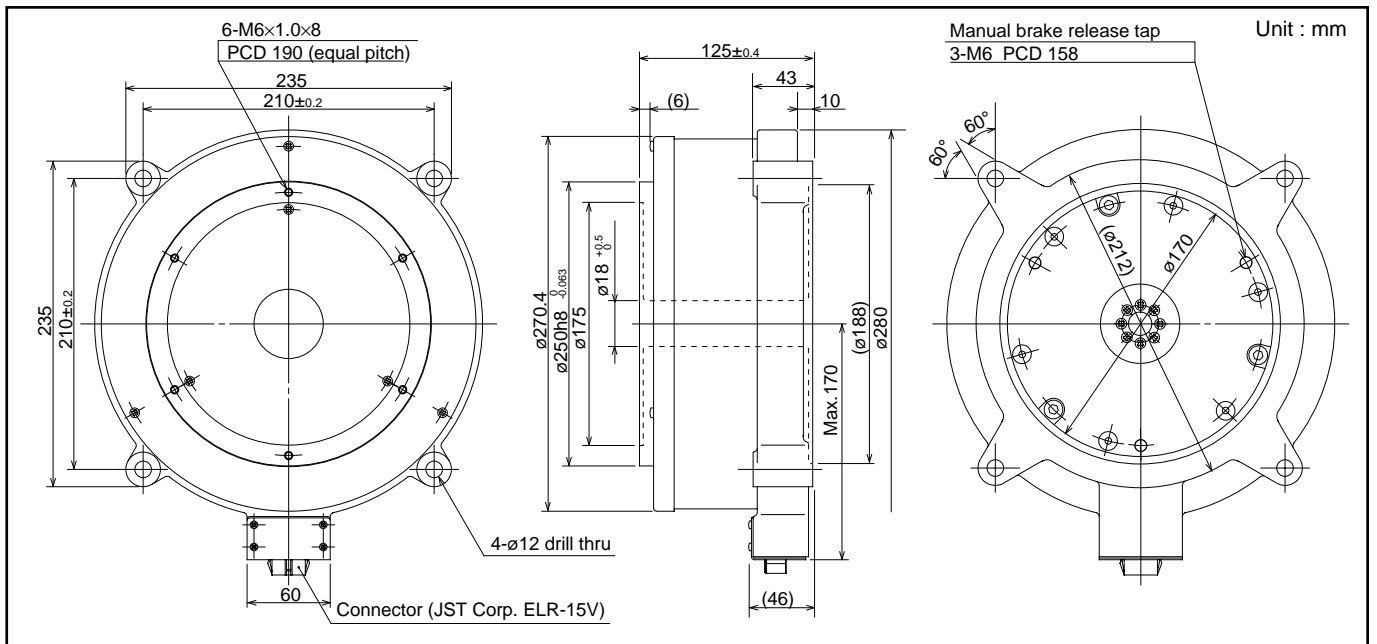
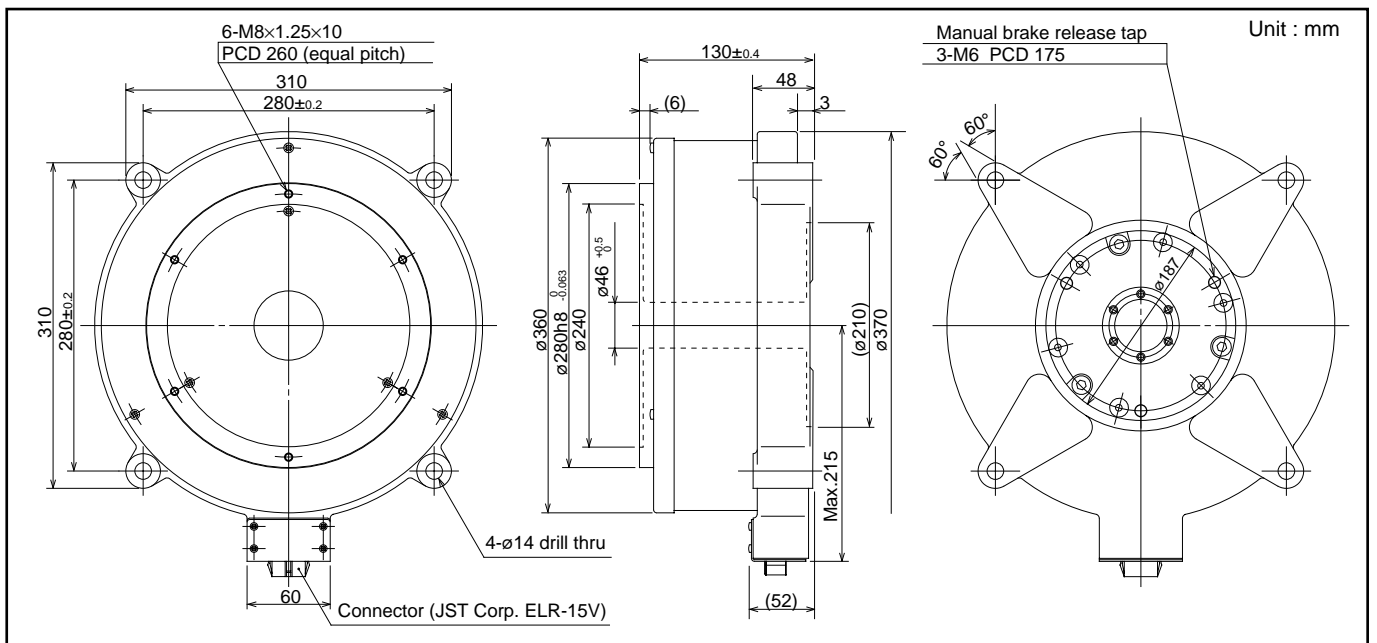

Figure 3-11: M-YS5120FG001



(3) Low profile type

Figure 3-12: M-YS2005FN001

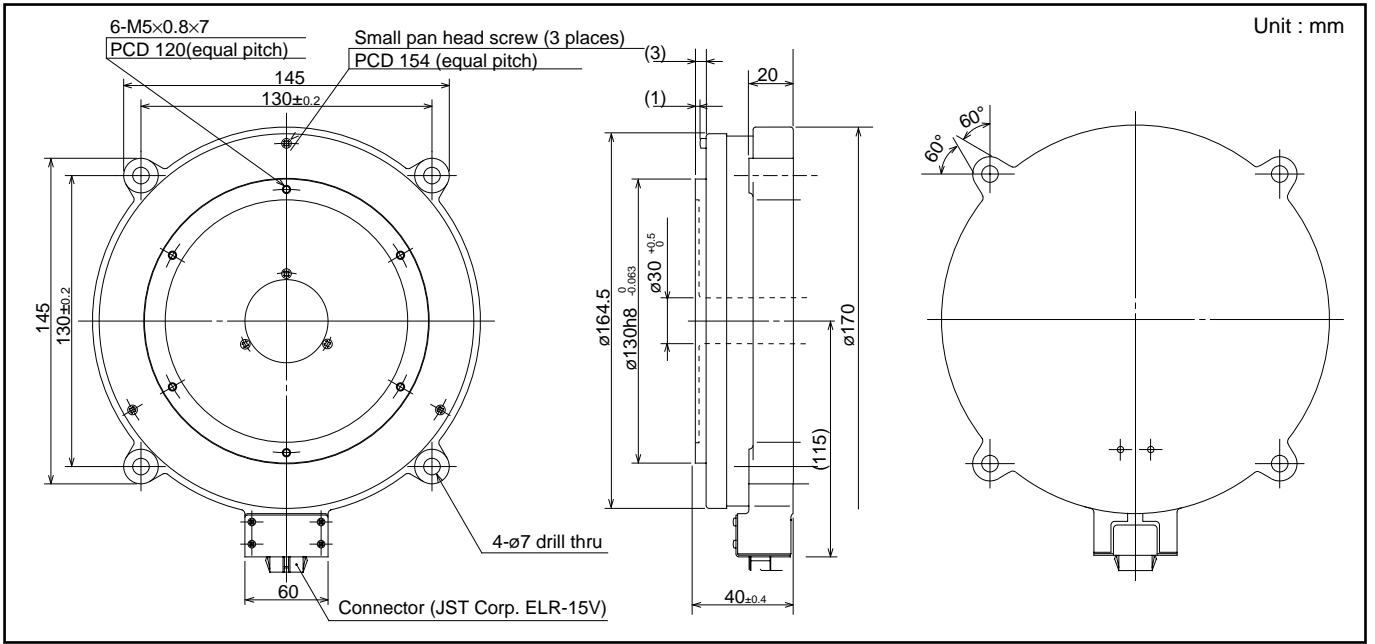
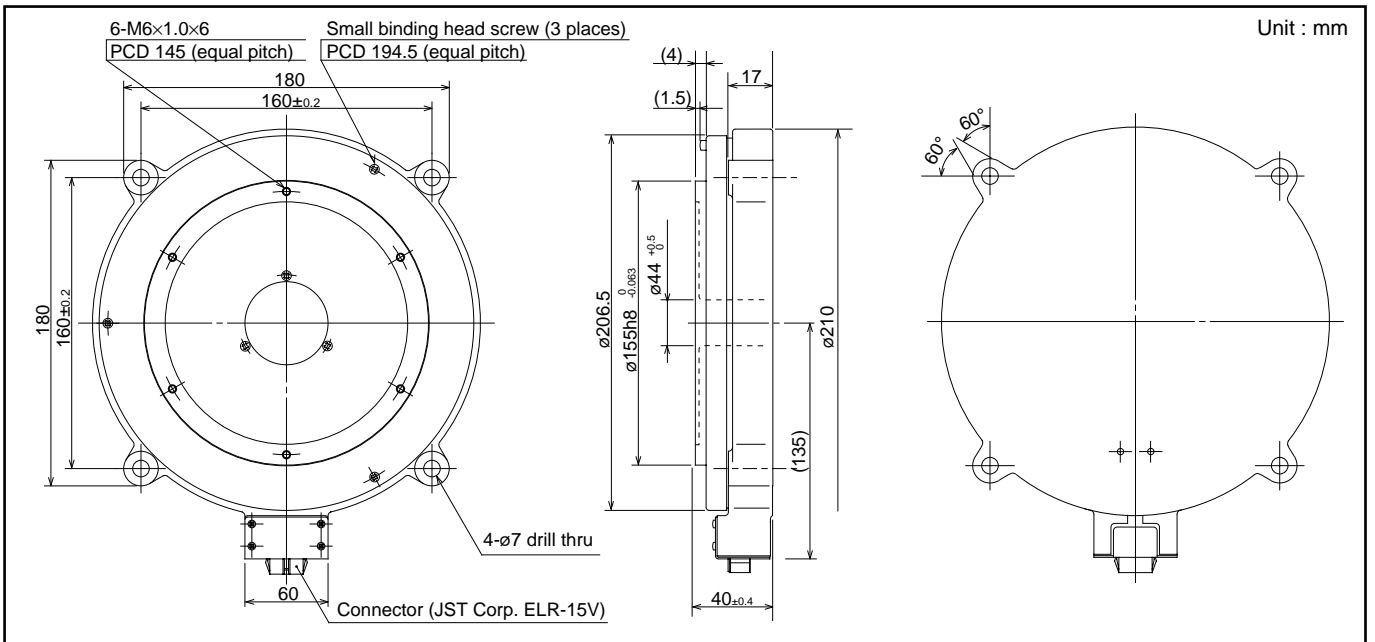

Figure 3-13: M-YS3008FN001



3.1.2. JS Series Motor

3.1.2.1. Name of Parts

Figure 3-14

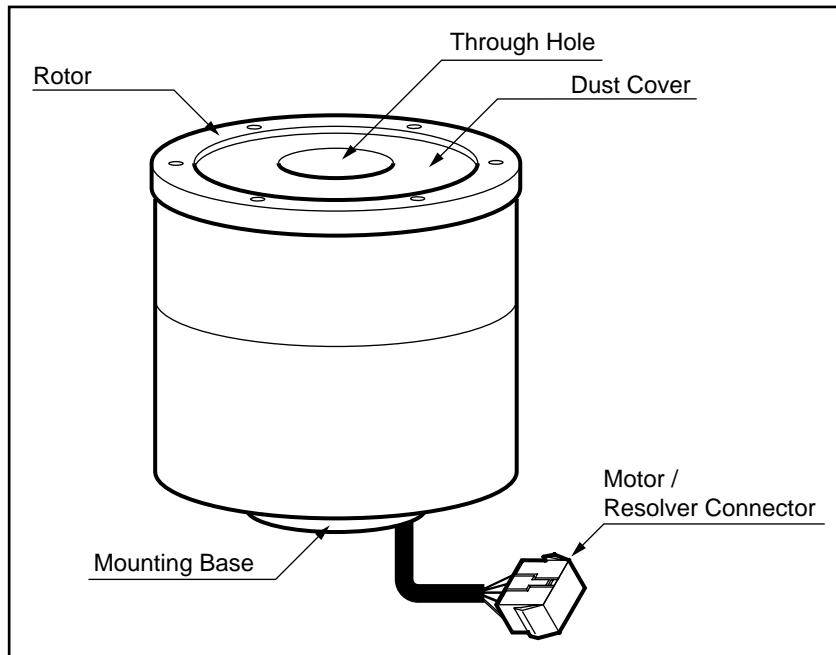

3.1.2.2. Specification

- JS series Motor can be run on either 100V/110V or 200V/220V AC.

Table 3-4: Specification

Motor reference No.		M-JS0002FN001	M-JS1003FN001	M-JS2006FN001	M-JS2014FN001
Item (unit)					
Motor outside diameter	(mm)	75	100	130	
Maximum torque	(N·m)	2	3	6	14
Maximum current/phase	(A)	1.5	1.5	3	
Allowable axial load	(N)	950	1960	3700	
Allowable moment load	(N·m)	10	40	60	
Axial rigidity	(mm/N)	1.6×10^{-5}	1.4×10^{-5}	7.4×10^{-6}	
Moment rigidity *1	(rad/N·m)	2.8×10^{-5}	1.4×10^{-5}	4.8×10^{-6}	
Maximum stall torque	(N·m)	1.4	2.1	4.2	9.8
Rotor moment of inertia	(kg·m ²)	0.002	0.00375	0.00525	0.0095
Rotor inertia GD ²	(kgf·m ²)	0.008	0.015	0.021	0.038
Mass	(kg)	2.4	3.2	4.8	5.5
Operating conditions		Temperature: 0~40°C, Humidity: 20~80% , Use indoors in a dust-free condition.			
Maximum speed	(S ⁻¹ (r.p.s.))	4.5		3	
Resolution	(p/rev)	409600		614400	
Positioning accuracy	(sec)	300		150	
Repeatability	(sec)	±3.2		±2.1	
Compatible Driver Unit	AC200V	M-ESAJ0002A25	M-ESA-J1003A25	MESA-J2006A25	M-ESA-J2014A25
	AC100V	M-ESAJ0002C25	M-ESA-J1003C25	MESA-J2006C25	M-ESA-J2014C25

*1 These values assume that the Motor is mounted on a rigid base.

SI unit system	1N = 0.102 kgf = 0.225lb
	1N·m = 0.102 kgf·m = 0.738 ft·lb

● **How to calculate axial and moment load**

Caution : ● *Do not apply excessive load to the Motor.*
An excessive load more than specified in Table 3-2 may result in premature Motor failure.

● *Followings show how to calculate the loads.*

Figure 3-15

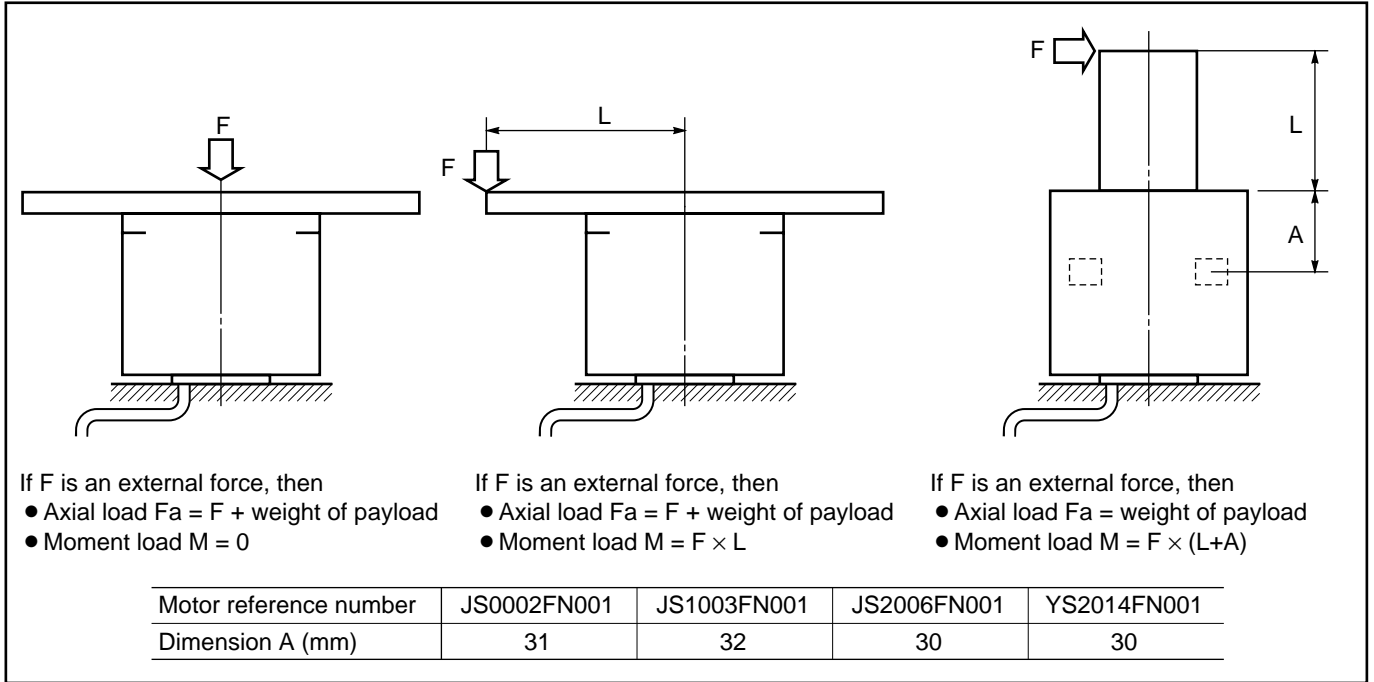

3.2. Driver Unit

3.2.1. Name of Parts

Figure 3-20

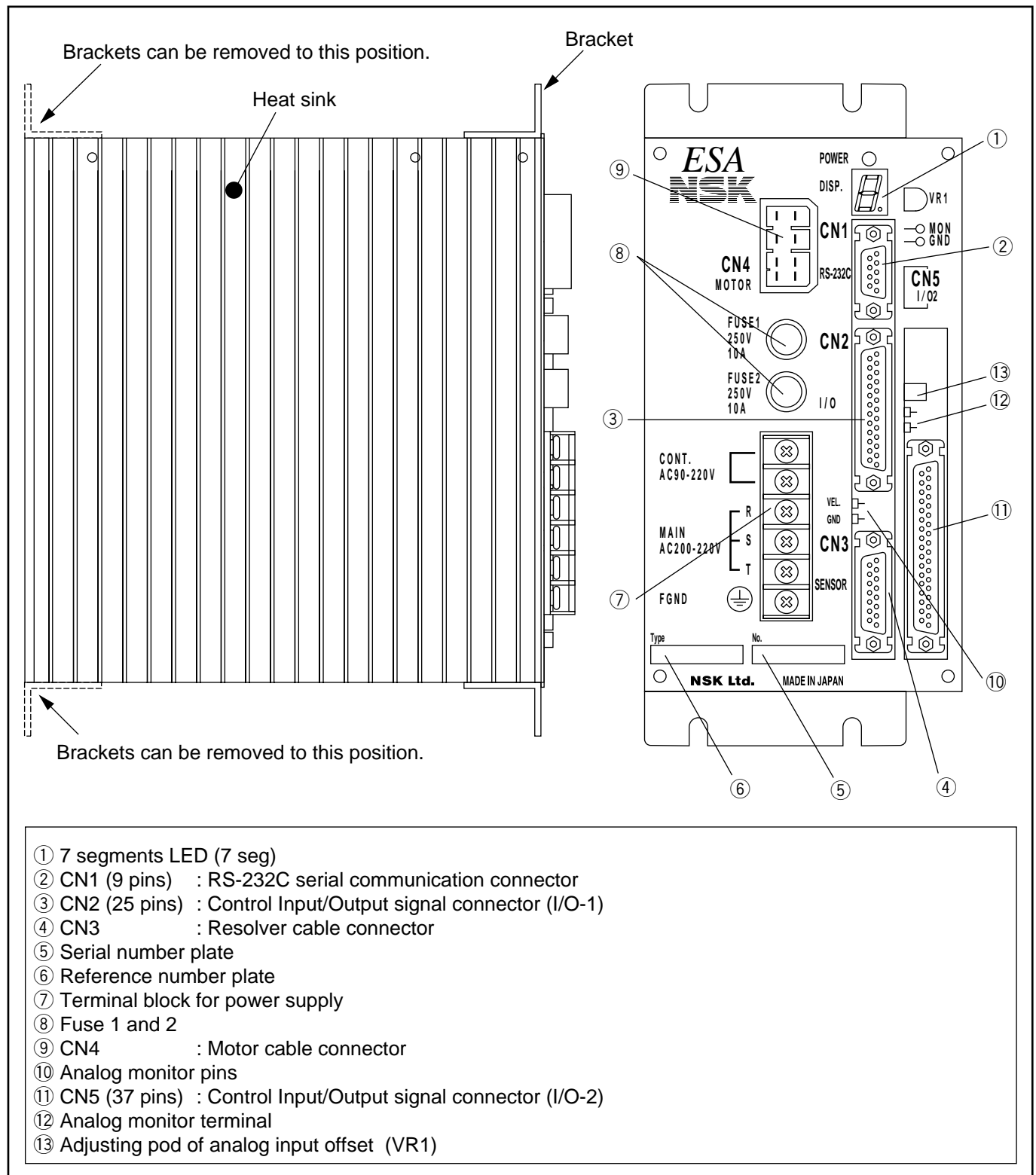

3.2.2. General Specification

● Control mode

- Closed loop, P·PI position control

● Operation mode

- Pulse train position command
- Programmable control
- RS-232C serial communication command
- Return Home operation
- Jog

● Power supply capacity

(1) AC200V/220V ± 10%

Table 3-5: Power supply capacity

Driver Unit Reference No.	Main power Max. (exclude surge current)	Control power Max. (exclude surge current)
M-ESA-Y2005A25	0.5 kVA	50 VA
M-ESA-Y2020A25	1.0 kVA	
M-ESA-Y3008A25	0.6 kVA	
M-ESA-Y3040A25	1.2 kVA	
M-ESA-Y4080A25	1.4 kVA	
M-ESA-Y5120A25	1.5 kVA	
M-ESA-Y5240A25	2.0 kVA	
M-ESA-J0002A25	0.7 kVA	
M-ESA-J1003A25	0.7 kVA	
M-ESA-J2006A25	0.9 kVA	
M-ESA-J2014A25	1.0 kVA	

* For the power supply capacity of RS and SS series motors, refer to their specification document.

Table 3-6: Surge and leakage current

	Control power	Main power
Surge current	14A	140A
Leakage current	(40 ^{HZ} ~ 1 ^{KHZ})	5 mA r.m.s
	(~1 ^{MHZ})	35 mA r.m.s

(2) AC100V/110V ± 10 %

Table 3-7: Power supply capacity

Driver Unit Reference No.	Main power Max. (exclude surge current)	Control power Max. (exclude surge current)
M-ESA-Y2005C25	0.3 kVA	50 VA
M-ESA-Y2020C25	0.7 kVA	
M-ESA-Y3008C25	0.3 kVA	
M-ESA-Y3040C25	0.9 kVA	
M-ESA-Y4080C25	1.0 kVA	
M-ESA-Y5120C25	1.0 kVA	
M-ESA-J0002C25	0.4 kVA	
M-ESA-J1003C25	0.4 kVA	
M-ESA-J2006C25	0.7 kVA	
M-ESA-J2014C25	0.7 kVA	

* For the power supply capacity of RS and SS series motors, refer to their specification document.

Table 3-8: Surge and leakage current

	Control power	Main power
Surge current	7A	80A
Leakage current	(40 ^{HZ} ~ 1 ^{KHZ})	3 mA r.m.s
	(~1 ^{MHZ})	20 mA r.m.s

● Environmental specification

Table 3-9

Vibration resistance		0.5 G
Line noise resistance		1500V 1 μ S (by noise simulator)
Mass		2.5 kg
Environmental condition	In operation	Temperature: 0 ~ 50°C Humidity: 20 ~ 90 % (no condensation)
	In storage	Temperature: - 20 ~ 70°C indoor condition

3.2.3. Functional Specification

● Control mode can be selected by the parameter SL.

- SL1: Torque control mode
- SL2: Velocity control mode
- SL3: Position control mode

● Position control mode

- RS-232C serial communication command
- Programmable control (internal programmable indexer)
 - Maximum 64 channels
- Pulse train input operation
 - CW/CCW or
 - Pulses/direction or
 - Phase A-Phase B
- Jog operation
- Home Return operation

● Velocity control mode

- RS-232C serial communication
- Analog \pm 10V

● Torque control mode

- RS-232C serial communication
- Analog \pm 10V

● Position detector resolution (Resolver)

Table 3-10

Resolver resolution Motor type	Automatic resolution switching or 12-bit setting	10-bit setting
YS, JS1, JS2, RS	614400 pulses/rev.	153600 pulses/rev.
SS	491520 pulses/rev.	122880 pulses/rev.
AS, BS, JS0	409600 pulses/rev.	102400 pulses/rev.

● **Maximum velocity**

Table 3-11

Motor type	Resolver resolution	
	12 bit setting	Automatic resolution switching or 10 bit setting
YS, JS1, JS2, RS	1 r.p.s.	3 r.p.s.
SS	1.25 r.p.s.	3.75 r.p.s.
AS, BS, JS0	1.5 r.p.s.	4.5 r.p.s.

● **Encoder output signal : ϕA , ϕB and ϕZ (MSB)**

- Signal output format:
 - ϕA , ϕB : Line driver
 - ϕZ (MSB) : Line driver/ Open corrector selectable (It can be switched by a jumper pin 1.)

Table 3-12: Resolution

Motor type	Resolver resolution		ϕZ (MSB)
	$\phi A, \phi B$		
	12-bit setting	10-bit setting	
YS, JS1, JS2, RS	153600 pulses/rev.	38400 pulses/rev.	150 pulses/rev.
SS	122880 pulses/rev.	30720 pulses/rev.	120 pulses/rev.
AS, BS, JS0	102400 pulses/rev.	21600 pulses/rev.	100 pulses/rev.

● **Control I/O signal**

- Input signals : Emergency stop, Servo on, Home position limit, Run move, Programmable indexer channel switching (max. 64 channels) Jog and Overtravel limit
- Output signals : Driver Unit ready, In position and Brake^{*1}

*1: The brake output signal is for controlling the brake. It cannot be used to supply power to an electromagnetic brake.

● **Alarms**

- Excess position error, Software thermal over, Travel limit over, Controller error, Resolver error, Motor over current, Power amplifier overheat, Main power voltage abnormal and Control power low voltage

● **Monitor output**

- Analog monitor, Analog velocity and RS- 232C communication monitor
 - Current position, Alarm state, Servo parameters, etc.

● **Communication**

- Asynchronous RS-232C communication Baud rate: 9600 b.p.s.

● **Data back up**

- Backed up by EEPROM
- 100000 times for resetting/ deleting parameters

3.2.4. Jumper

- Jumper (JP1) is for selecting output format of θ Z position feedback signal.
- Jumper is inside of the Driver Unit. When setting Jumper, remove the side cover of the Driver Unit. Follow the procedure in Appendix 4: How to replace ESA25 Driver Unit.
- Figure 3-14 indicates the Jumper location.

Figure 3-21

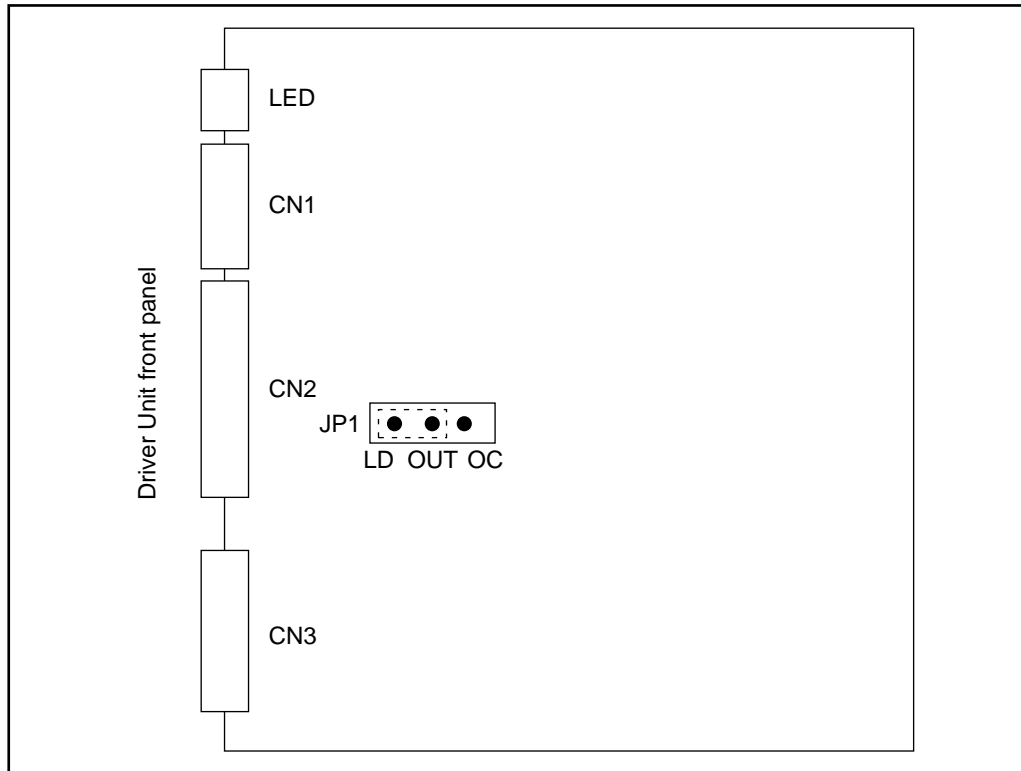
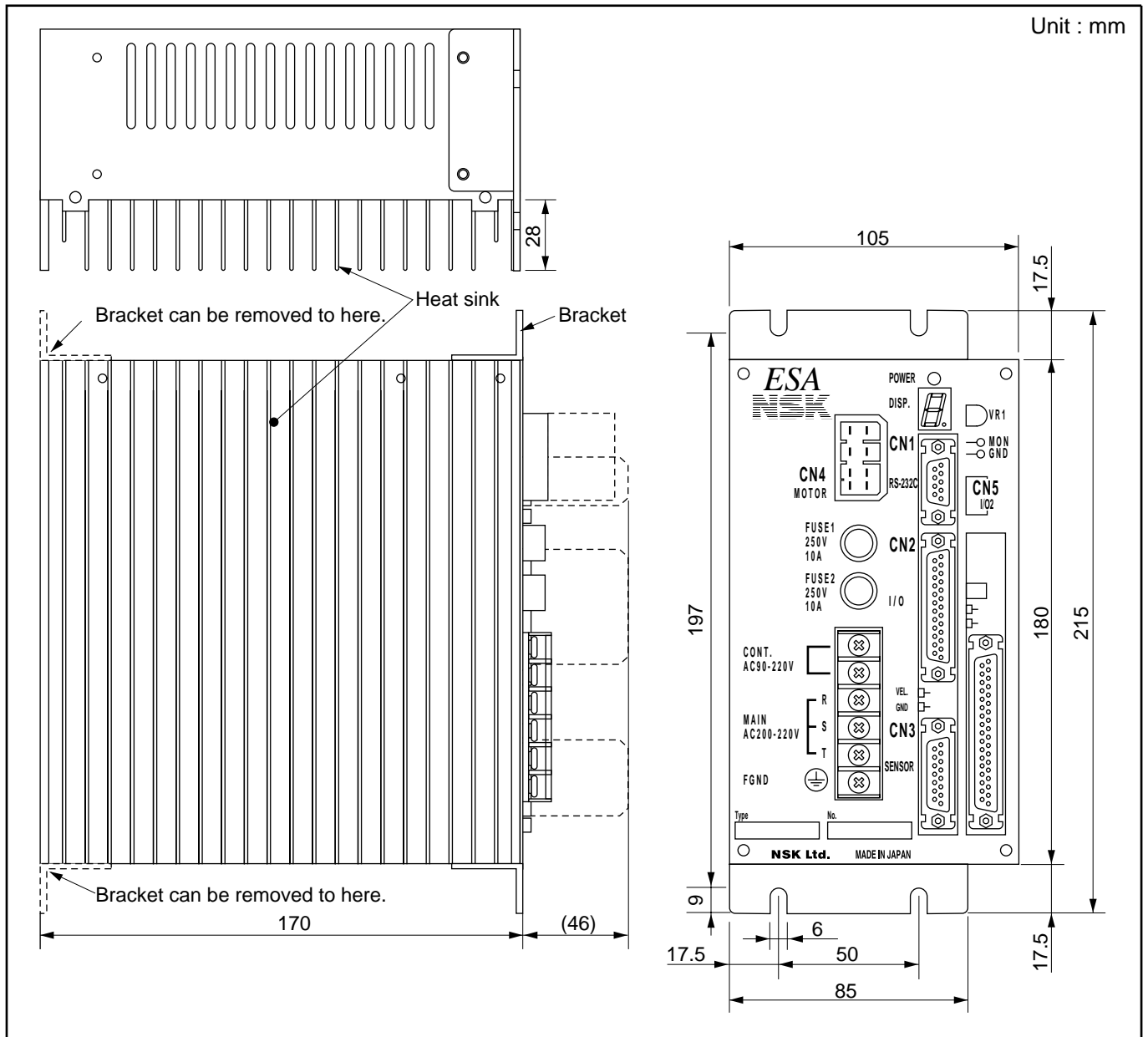

Table 3-13: Jumper setting.

Setting	θ Z output format
LD-Out short	Line driver (Shipping set)
OC-Out short	Open collector

3.2.5. Dimensions

Figure 3-22



3.3. Cable Set

- This section shows Cable Set for YS and JS series Motor.
- Refer to respective specification for SS and RS series Motor.
- For reference number and cable length, see “ 2.3. Standard Combination.”

3.3.1. Cable Set for YS Motor

Figure 3-23

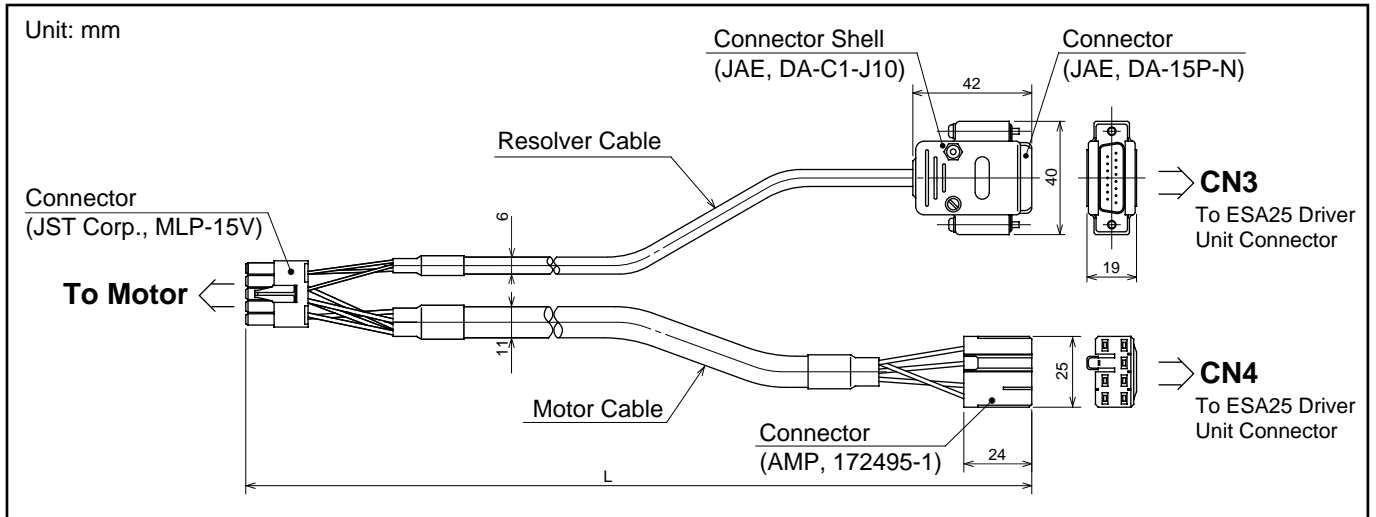

3.3.2. Cable Set for YS Motor with Brake

Figure 3-24

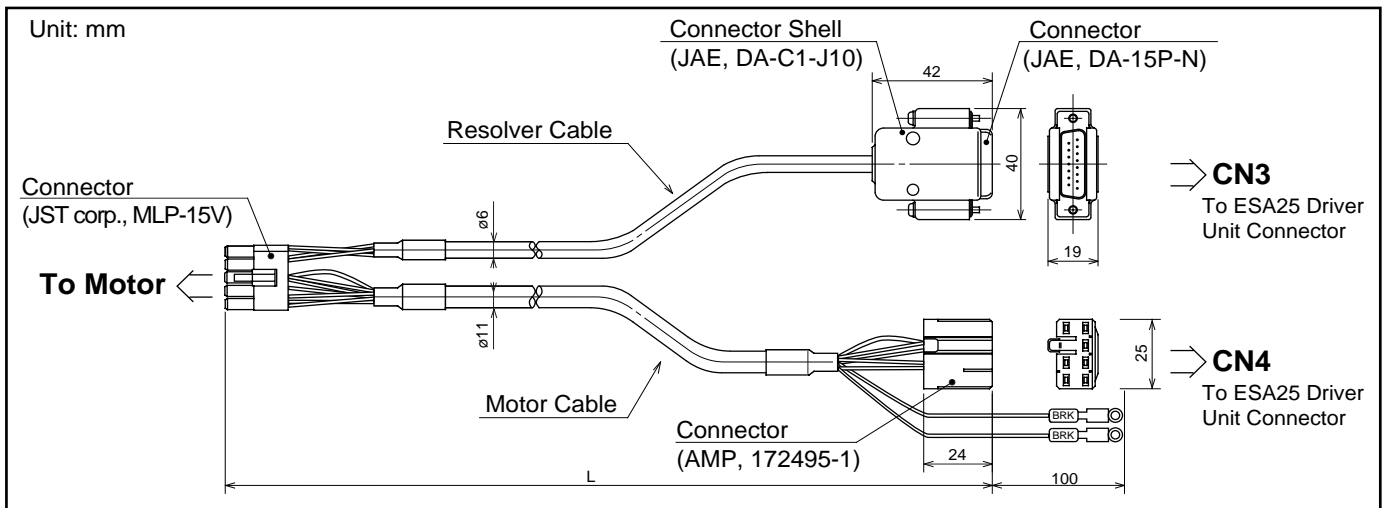

3.3.3. Cable Set for JS Motor

Figure 3-25

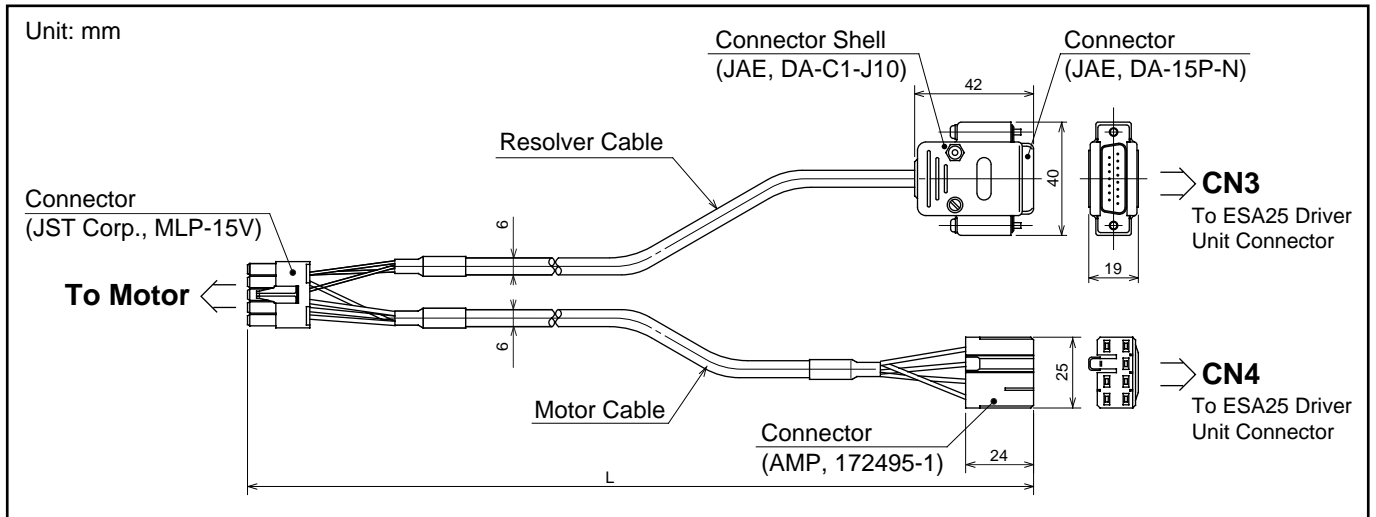

3.4. Handy Terminal

- FHT11 Handy Terminal is an easy to use hand held terminal with an RS-232C communication interface for Megatorque Motor System Driver Unit. FHT11 terminal connects directly to the CN1 connector on the ESA25 Driver Unit.

3.4.1. Name of Parts and Dimensions

Figure 3-26

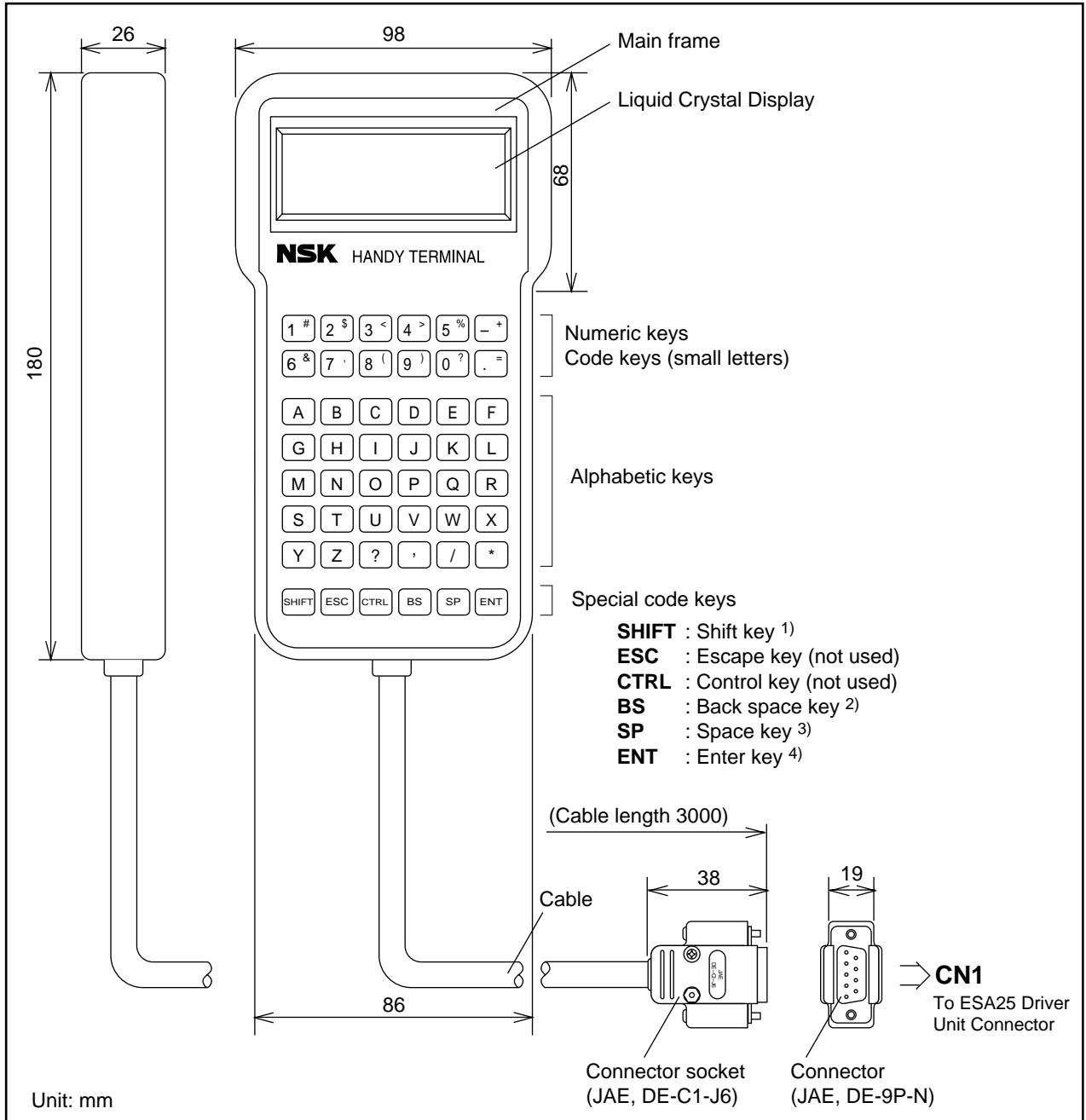

Note : (1) SHIFT: Press the code key while holding "SHIFT" key. (Small characters)

(2) BS : When correcting logged-in mistakes, press "BS" key.

(3) SP : Press "SP" key to have space between characters.

(4) ENT : Press "ENT" key at the end of the command or the parameter setting.

3.4.2. Specification

Table 3-14

Item	Specification	
Power source voltage	DC 5V \pm 5%	
Power consumption	200 mW	
Environment	Temperature	<ul style="list-style-type: none">● Operating : 0~50°C● Storage : -10~+65°C
	Humidity	35~85% (Non condensing)
RS-232C Interface	Data code	ASCII code
	Communication speed	9600 b.p.s
	Data bit	8 bit
	Stop bit	2 bit
	Start bit	1 bit
	Parity check	None
Mass	250g (exclude cable)	

4. Connector Specification

4.1. CN1: RS-232C Serial Communication Connector

- NSK’s Handy Terminal FHT11 (sold separately) can be used as an RS-232C terminal.

Table 4-1

Driver Unit connector	Japan Aviation Electronics Industry, Limited	DBLC-J9SAF-13L6
Mating connector type (user device side)	Japan Aviation Electronics Industry, Limited (to be prepared by the user)*	DE-9P-N
Mating connector shell type (user device side)	Japan Aviation Electronics Industry, Limited (to be prepared by the user)*	DE-C2-J6

* These connectors are not necessary if NSK Handy Terminal FHT11 is used.

4.1.1. CN1 Pin-Out

Figure 4-1: CN1 Pin-out

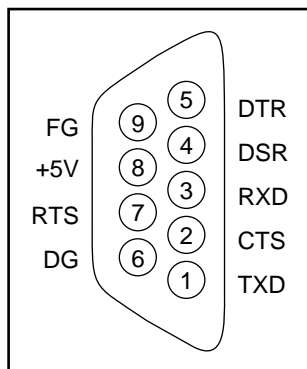

4.1.2. CN1 Signal List

Table 4-2: CN1 Signal List

Pin	Signal Name	I/O	Function
1	TXD	Output	Transmit data
2	CTS	Input	Clear to send
3	RXD	Input	Receive data
4	DSR	Input	Data set ready
5	DTR	Output	Data terminal ready
6	SG	–	Digital signal ground
7	RTS	Output	ø Ready to send
8	+5V	Output	Never connect
9	FG	–	Frame ground (shield)

4.1.3. Sample Wiring Diagram

- Connect the ESA25 Driver Unit with the controller (e.g., personal computer) in accordance with its RS-232C control signal specification.

● RTS Control / CTS Monitoring Active (standard wiring)

Figure 4-2

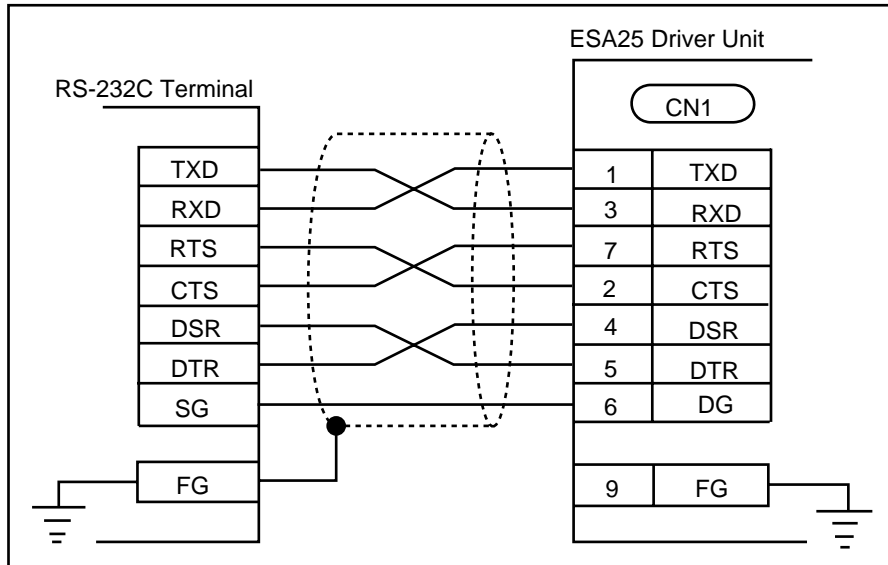

● RTS Control / CTS Monitoring Inactive

Important : When wired as shown below, always confirm the echo-back from Driver Unit or send the data slowly. With this wiring, Driver Unit may not accept the whole data when data is sent at high speed and large amount.

Figure 4-3

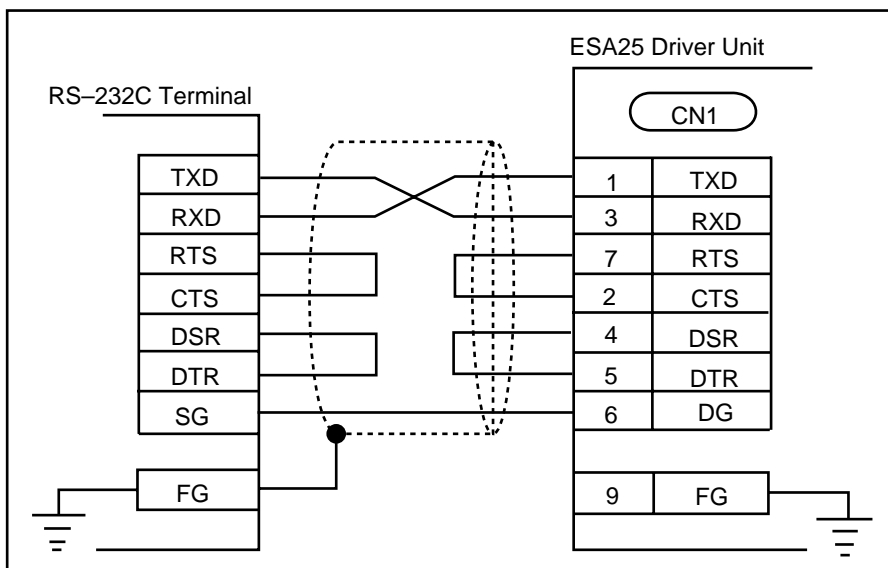

4.2. CN2,CN5: Control I/O Signal Connectors

- Table 4-3 shows connector types of CN2 and CN5.

Table 4-3

Driver Unit side connector	CN2	Japan Aviation Electronics Industry, Ltd.	DBLC-J25SAF-13L6
	CN5		DCLC-J37SAF-13L9
Mating connector (user device side)	CN2	Japan Aviation Electronics Industry, Ltd.	DB-25P-N *1
	CN5		DC-37P-N *1
Mating connector shell type (user device side)	CN2	Japan Aviation Electronics Industry, Ltd.	DB-C2-J9 *1
	CN5		DC-C8-J13-F4-1 *1

* 1: Provided with Driver Unit

- Wiring precautions for CN2 and CN5 connectors are described below.
 - ① Use shielded cable for CN2 and CN5 connectors and a twisted pair cables must be used for the pulse train input and position feed back signals.
 - ② These cables should be laid in an independent duct separate from the power line.
 - ③ Connect one end of the cable shield to the frame ground.

Caution : Check for wiring mistake of external power supply polarity and shorting between connector pins.

4.2.1. Pin- Out (CN2, CN5)

Figure 4-4

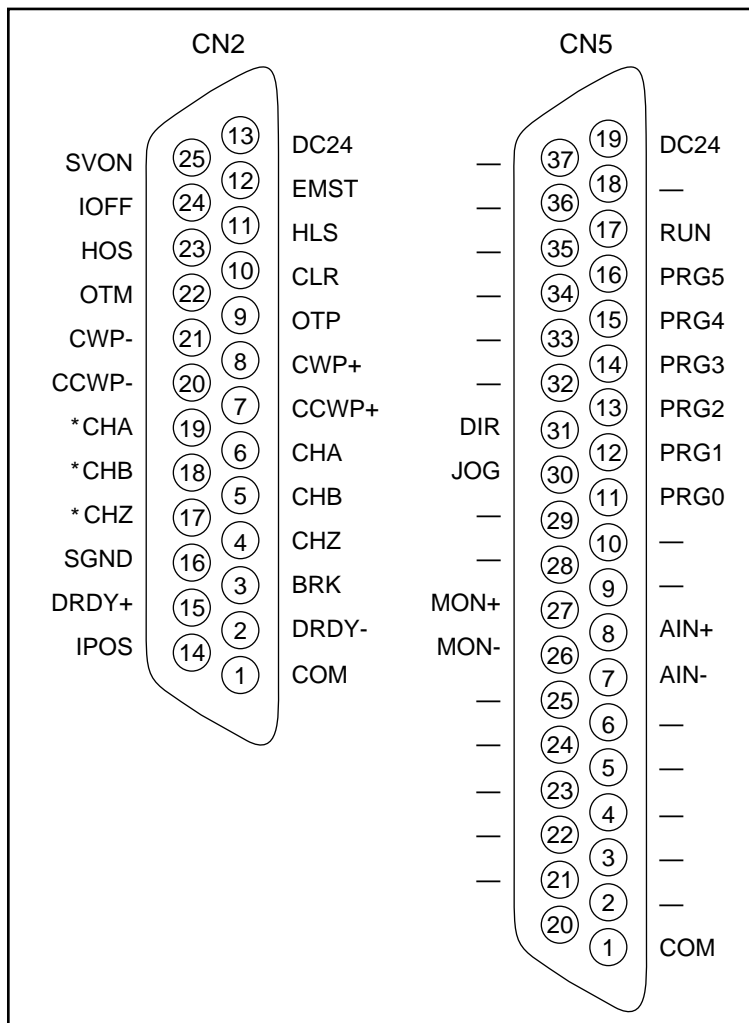

4.2.2. Signal Name and Function (CN2, CN5)

Table 4-4: CN2

Pin	Signal Name	I/O	Function
1	COM	Output	Output COMMON
2	DRDY-	Output	Driver Unit ready (-)
3	BRK	Output	Brake control signal (normally closed)
4	CHZ*	Output	Position feedback ϕZ /digital position data MSB*
5	CHB	Output	Position feedback ϕB
6	CHA	Output	Position feedback ϕA
7	CCWP+	Input	Counter clockwise pulse (+)
8	CWP+	Input	Clockwise pulse (+)
9	OTP	Input	+ direction overtravel limit switch (CW direction)
10	CLR	Input	Clear
11	HLS	Input	Home limit switch
12	EMST	Input	Emergency stop
13	DC24	Input	24 VDC external supply
14	IPOS	Output	In-position
15	DRDY+	Output	Driver Unit ready (+)
16	SGND	—	Signal ground
17	★CHZ*	Output	Position feedback ★ ϕZ /digital position data ★MSB*
18	★CHB	Output	Position feedback ★ ϕB
19	★CHA	Output	Position feedback ★ ϕA
20	CCWP-	Input	Counter clockwise pulse (-)
21	CWP-	Input	Clockwise pulse (-)
22	OTM	Input	- direction overtravel limit switch (CCW direction)
23	HOS	Input	Home return start
24	IOFF	Input	Integration off
25	SVON	Input	Servo-on

* The parameter FZ (RS-232C communication interface) is used to select between the position feedback signal ϕZ and the digital position signal ★MSB.

Table 4-5: CN5

Pin	Signal Name	I/O	Function
1	COM	Output	Output COMMON
2	—	—	Do not connect
3	—	—	Do not connect
4	—	—	Do not connect
5	—	—	Do not connect
6	—	—	Do not connect
7	AIN-	Input	Analog command (-)
8	AIN+	Input	Analog command (+)
9	—	—	Do not connect
10	—	—	Do not connect
11	PRG0	Input	Internal program channel selection bit 0
12	PRG1	Input	Internal program channel selection bit 1
13	PRG2	Input	Internal program channel selection bit 2
14	PRG3	Input	Internal program channel selection bit 3
15	PRG4	Input	Internal program channel selection bit 4
16	PRG5	Input	Internal program channel selection bit 5
17	RUN	Input	Start internally programmed operation
18	—	—	Do not connect
19	DC24	Input	DC 24V external power supply
20	—	—	Do not connect
21	—	—	Do not connect
22	—	—	Do not connect
23	—	—	Do not connect
24	—	—	Do not connect
25	—	—	Do not connect
26	MON-	Output	Analog monitor output (-)
27	MON+	Output	Analog monitor output (+)
28	—	—	Do not connect
29	—	—	Do not connect
30	JOG	Input	Jogging
31	DIR	Input	Jog direction
32	—	—	Do not connect
33	—	—	Do not connect
34	—	—	Do not connect
35	—	—	Do not connect
36	—	—	Do not connect
37	—	—	Do not connect

Caution : For the Input / Output signals of special-order Driver Unit, refer to its special document.

4.2.3. Setting the Polarity (A or B contact) of the Input Ports

- The shipping set of polarity for all CN2 input signal ports is A contact.
- The polarity of some input signal ports can be changed to B contact in an ESA25 Driver Unit.
- The ports of which the polarity can be changed are only four signals below. The other ports are fixed to A contact.
 - EMST : Emergency stop
 - HLS : Home limit switch
 - OTP : + direction overtravel limit switch (CW direction)
 - OTM : - direction overtravel limit switch (CCW direction)
- The polarity can be changed with the parameter AB.
- The password input is necessary before inputting AB parameter.
- Table 4-6 shows the data and port. Refer to “Setting Example” below and the explanation of AB parameter.

Table 4-6

Data digit	n1	n2	n3	n4	n5	n6	n7	n8
CN2 Pin No.	25	12	24	11	23	10	22	9
Signal name	SVON	EMST	IOFF	HLS	HOS	CLR	OTM	OTP

- Explanation of data
 - 0 = A contact (normally open)
 - 1 = B contact (normally closed)
 - X = At the time of input : The port set to X does not change polarity.
 - = At the time of read-out : For the port which is shown as “X”, the polarity can not be changed. (fixed to A contact)
- See “11. Command and Parameter” for more details.

● **Setting Example**

- (1) **SHIFT** **0 ?**
 Press the code key while holding down the SHIFT key.
- (2) **A** **B** **ENT**
 Input the command to read the setting of the AB parameter. Check the present polarity setting (in this example, all the input ports are set to A contact).
- (3) **/** **N** **S** **K** **SP**
O **N** **ENT**
 Input the password.
 The password acknowledgment message appears on th display.
- (4) **A** **B** **X** **1 #** **X** **X**
X **X** **X** **X** **ENT**

```

:
: ?_

```

```

:
: ?AB
: ABX0X0XXXX
: _

```

```

: ABX0X0XXXX
: /NSK ON
: NSK ON
: _

```

```

: /NSK ON
: NSK ON
: ABX1XXXXXX
: _

```

The second bit following AB represents EMST. Set this bit to “1”, and the other bits to “X” (no change).

- Thus, the polarity of EMST input signal port has been changed to B contact.

4.2.4. Signal Specification

4.2.4.1. General Input

Applied Inputs: SVON, EMST, PRG0~5, RUN, HOS, HLS, JOG, DIR, OTP, OTM, CLR, IOFF

Table 4-7

Item	Specification
Input voltage	24 VDC \pm 10%
Input impedance	3.3 k Ω
Maximum current	10 mA (per input)

Figure 4-5

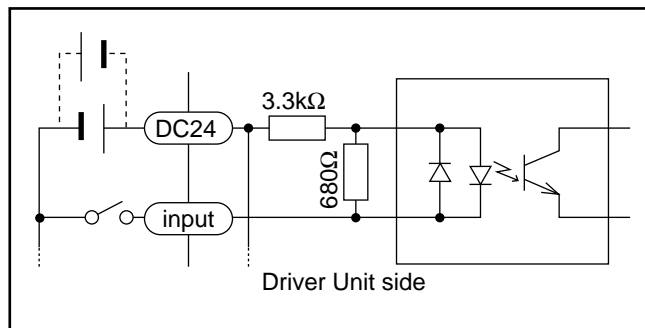

* The polarity of DC24V external supply may be reversed.

4.2.4.2. Pulse Train Input

Applied Inputs: CWP+, CWP-, CCWP+, CCWP-

Table 4-8

Item	Specification
Input voltage	5 VDC \pm 10%
Input impedance	240 Ω
Maximum current	25 mA

Figure 4-6

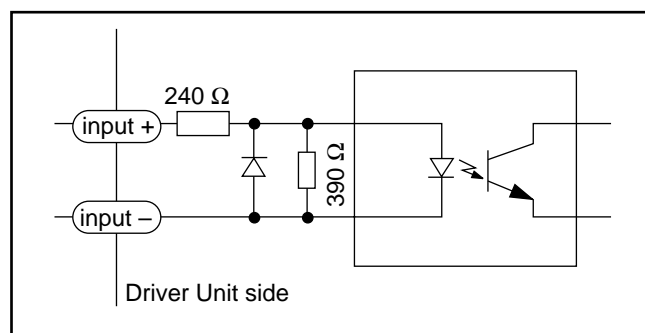

4.2.4.3. General Output

Applied Outputs: BRK, IPOS

Table 4-9

Item	Specification
Maximum load capacity	24 VDC/100 mA
Maximum saturated voltage	2 V or less

Figure 4-7

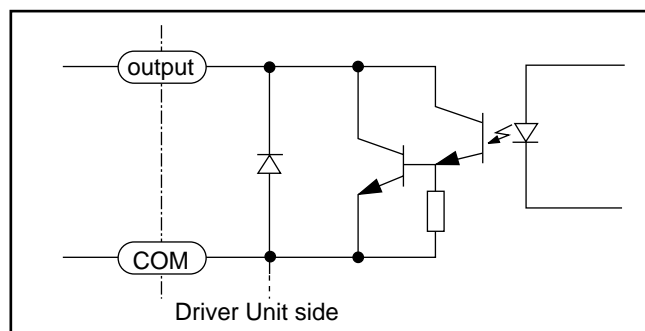

4.2.4.4. Alarm Output

Applied Outputs: DRDY+, DRDY-

Table 4-10

Item	Specification
Maximum load capacity	24 VDC/100 mA
Maximum saturated voltage	2 V or less

Figure 4-8

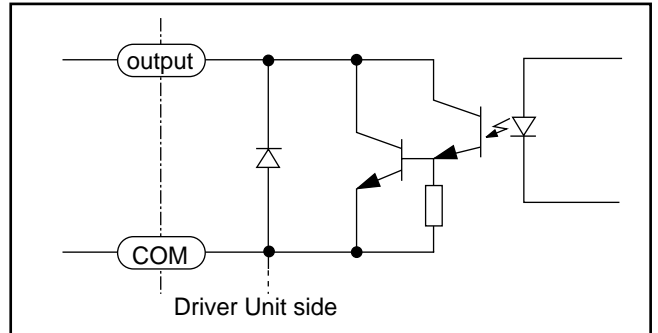

4.2.4.5. Position Feed Back

Applied Outputs: CHA, CHB, CHZ, *CHA, *CHB, *CHZ

Table 4-11

Item	Specification	
Output format	Line driver (CHA, CHB, *CHA, *CHB)	
	Line driver or open collector (CHZ, *CHZ) (Can be selected by Jumper 1. Refer to "3.2.4. Jumper")	
Output device	Texas Instruments SN75ALS192	
Recommended Line Driver	Texas Instruments SN75ALS193 or AM26LS32 or equivalent	
Maximum Line Receiver	100mA	For open collector
Maximum collector voltage	24V	
Saturated voltage	1V or less	

Figure 4-9

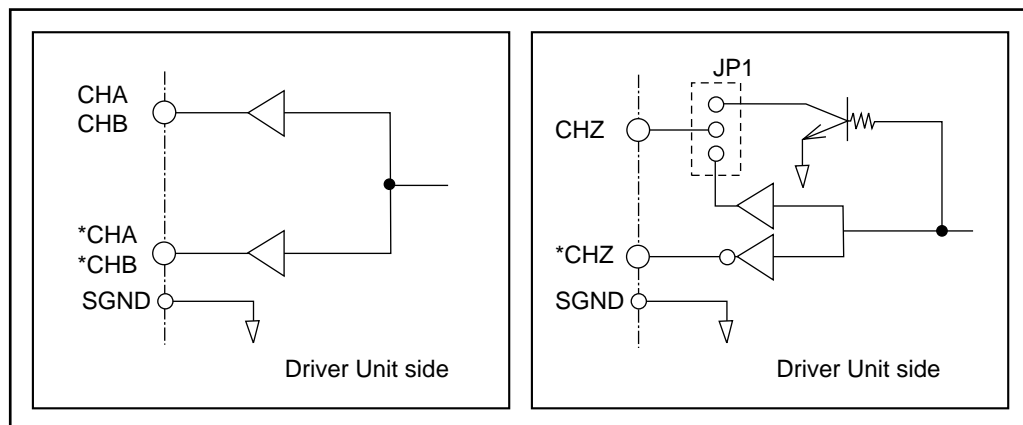

4.2.4.6. Analog Command Input

Applied Inputs: AIN+, AIN-

Table 4-12

Item	Specification
Max. input voltage	$\pm 10\text{VDC}$
Input impedance	20 k Ω
Max. input current	0.5 mA

Figure 4-10

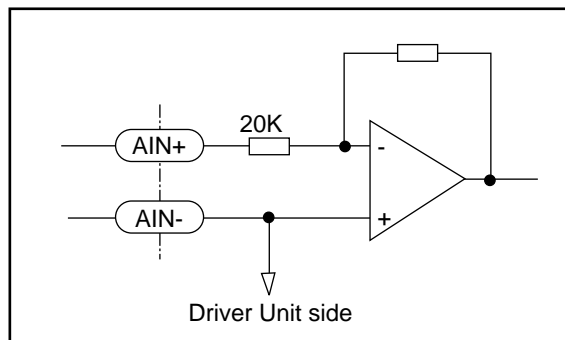

4.2.4.7. Analog Monitor Output

Applied Outputs: MON+, MON-

Table 4-13

Item	Specification
Output format	Ope-amp
Max. input voltage	$\pm 10\text{V} \pm 10\%$
Saturated voltage	4mA or less

Figure 4-11

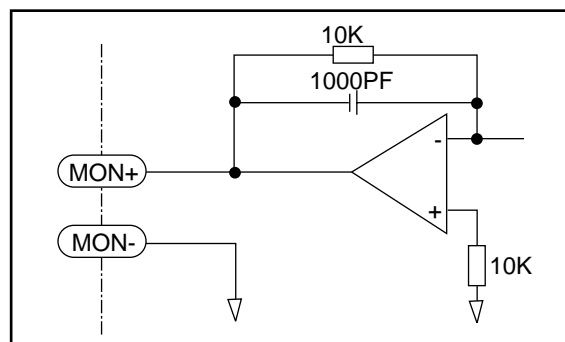

4.2.5. Wiring Example (CN2, CN5)

4.2.5.1. Position Control Mode Wiring Example

Figure 4-12

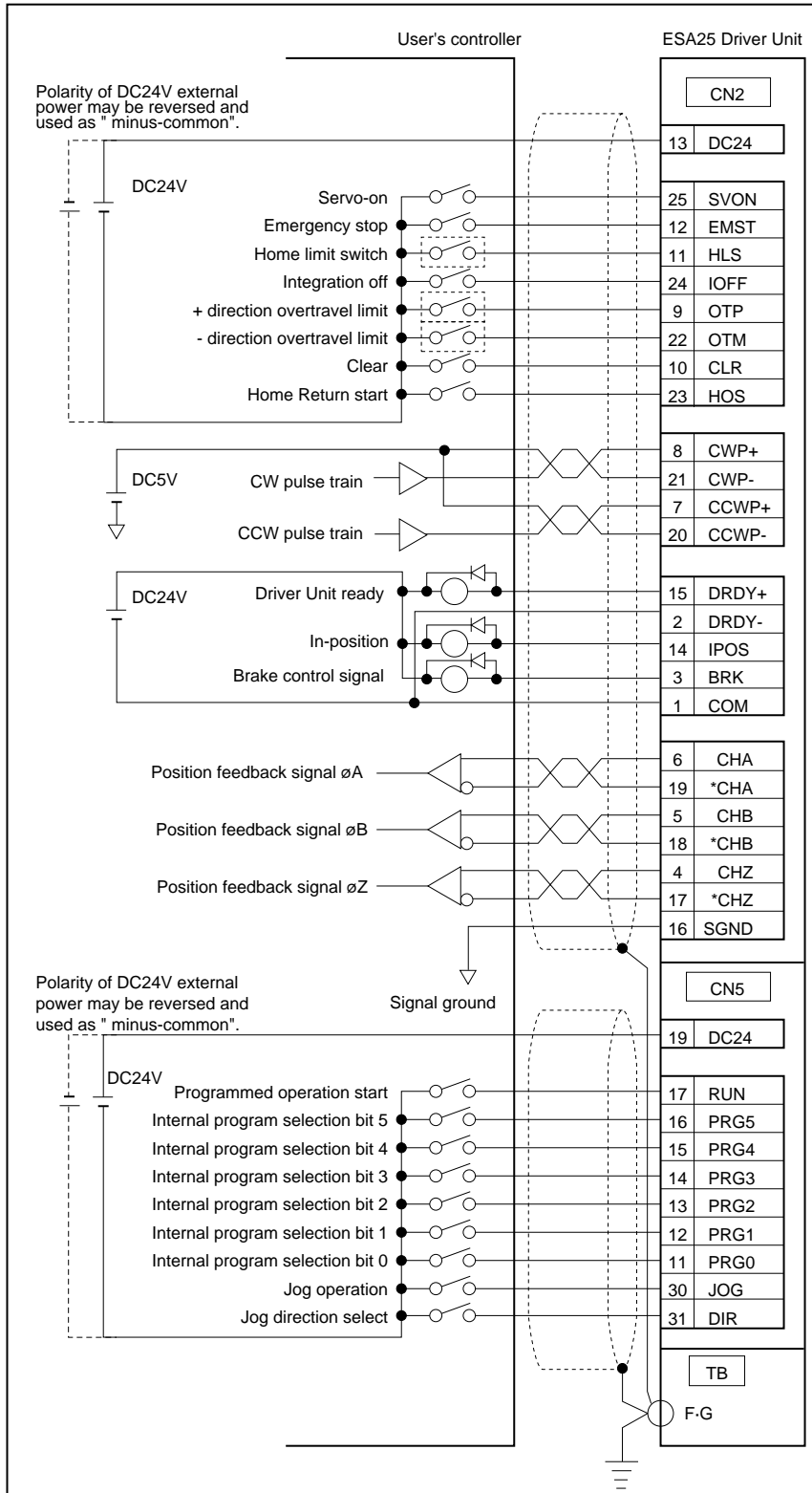

- Caution :**
- When using an inductive switch (e.g., relay), be sure to insert a surge killer circuit.
 - When the user installs sensors as the Home position limit switch, + direction overtravel limit and - direction overtravel limit switch, connect sensor output directly with the input port of the Driver Unit, not via the master controller.

4.2.5.2. Wiring Example of Velocity Control/Torque Control Mode

Figure 4-13

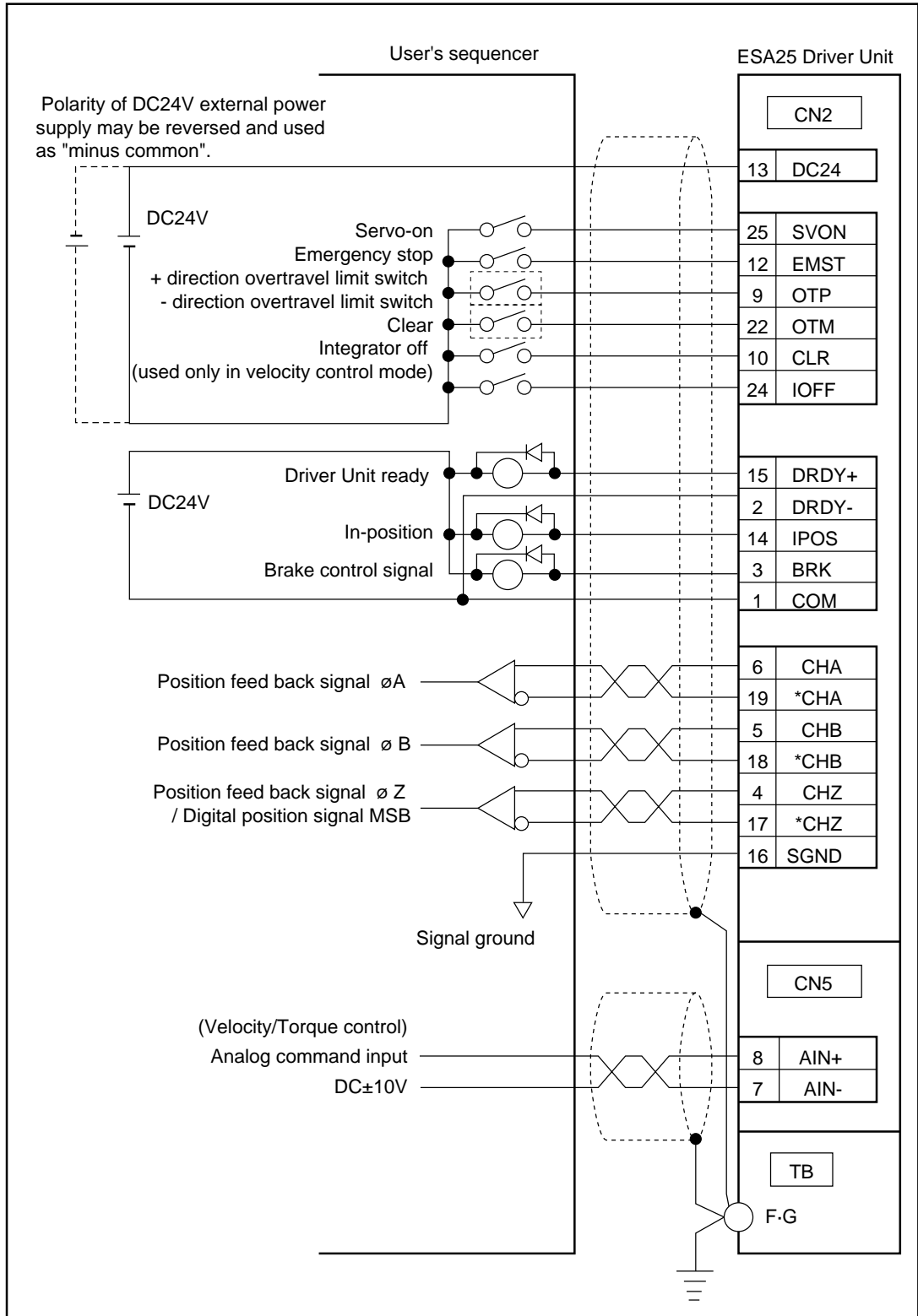

Caution : ● When using an inductive switch (e.g. relay), be sure to install a surge killer circuit.

- When the user installs sensors as the + direction overtravel limit switch and - direction overtravel limit switch, connect sensor output directly with the input port of the Driver Unit, not via the master controller.

4.2.5.3. Wiring Example of YS Series Motor with Brake

- The brake built in the YS series motors with brake is an electromagnetic type of negative action (brake to be released when the coil is turned on, and to be applied when the coil is turned off), being a non-backlash type.
- It is designed to provide security in case of power interruption, or to supply holding rigidity when the Motor is stopping.
- Use a dedicated brake power supply because the brake is designed to operate on a power supply of overexcitation system switching between full-wave and half-wave. [full-wave rectifying during overexcitation, half-wave rectifying during holding (rated excitation).]
 - Reference number of the brake power supply: M-FZ063

Table 4-14: Main specification

Power voltage	AC200V ± 10% 50 / 60 Hz	
Output voltage/current	Overexcitation	DC180V·4A Full -wave rectification
	Hold	DC90V·2A Half-wave rectification
Overexcitation time	0.35 sec	
Ambient temperature	0 ~ 40 °C	

Figure 4-14: Terminal block wiring

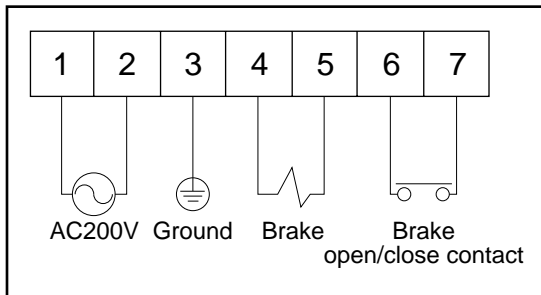

Caution : ● For brake on/off, use contacts with a capacity of more than 10 times the inductive load current at 180 VDC.

- Do not short-circuit No.4 and No.5 terminals with power on.
- Be sure to use No.6 and No.7 terminals to turn on/off the brake.
- Never open/close No.6 and No.7 terminals with AC power applied.

Table 4-15

Motor size	Inductive load current (A)
YS2020	0.36
YS3040	0.50
YS4080	0.66
YS5120	0.72

- The brake signal must be controlled through the user's sequence.

Figure 4-15: Recommended sequence diagram

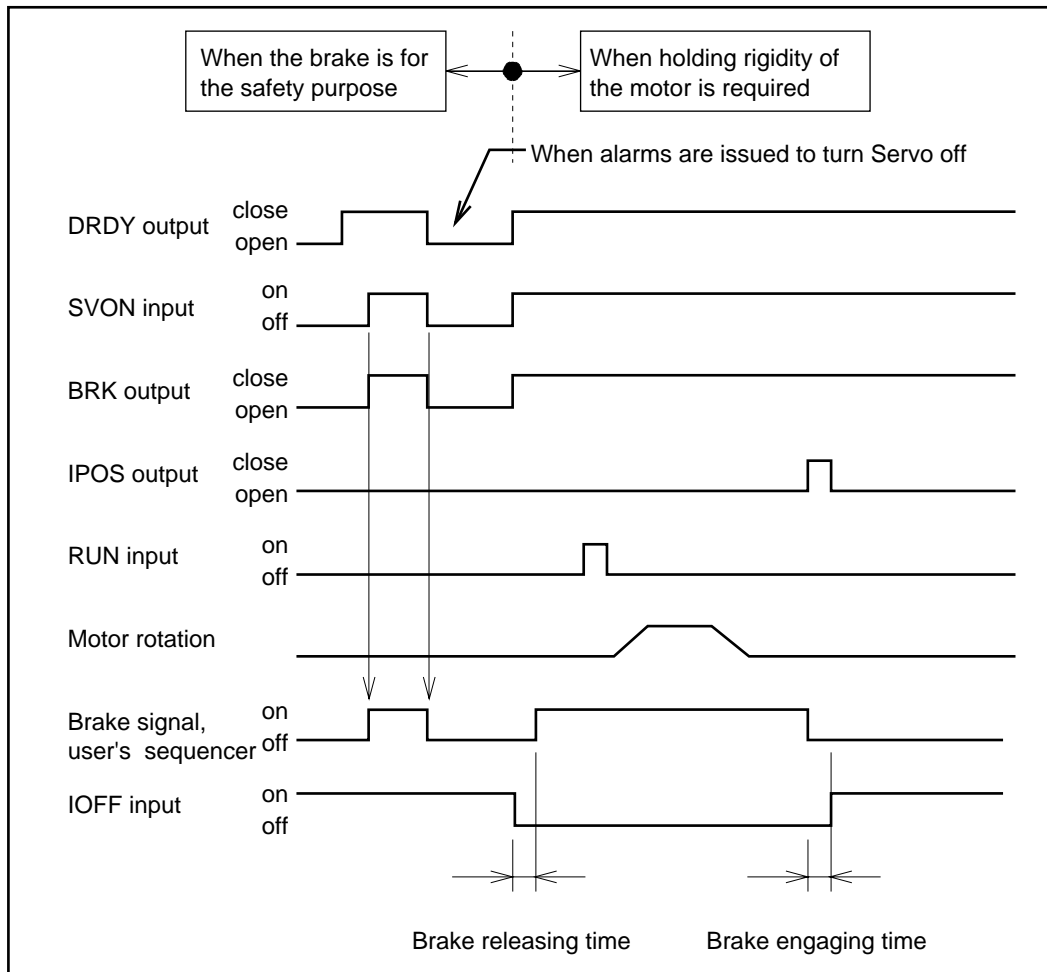
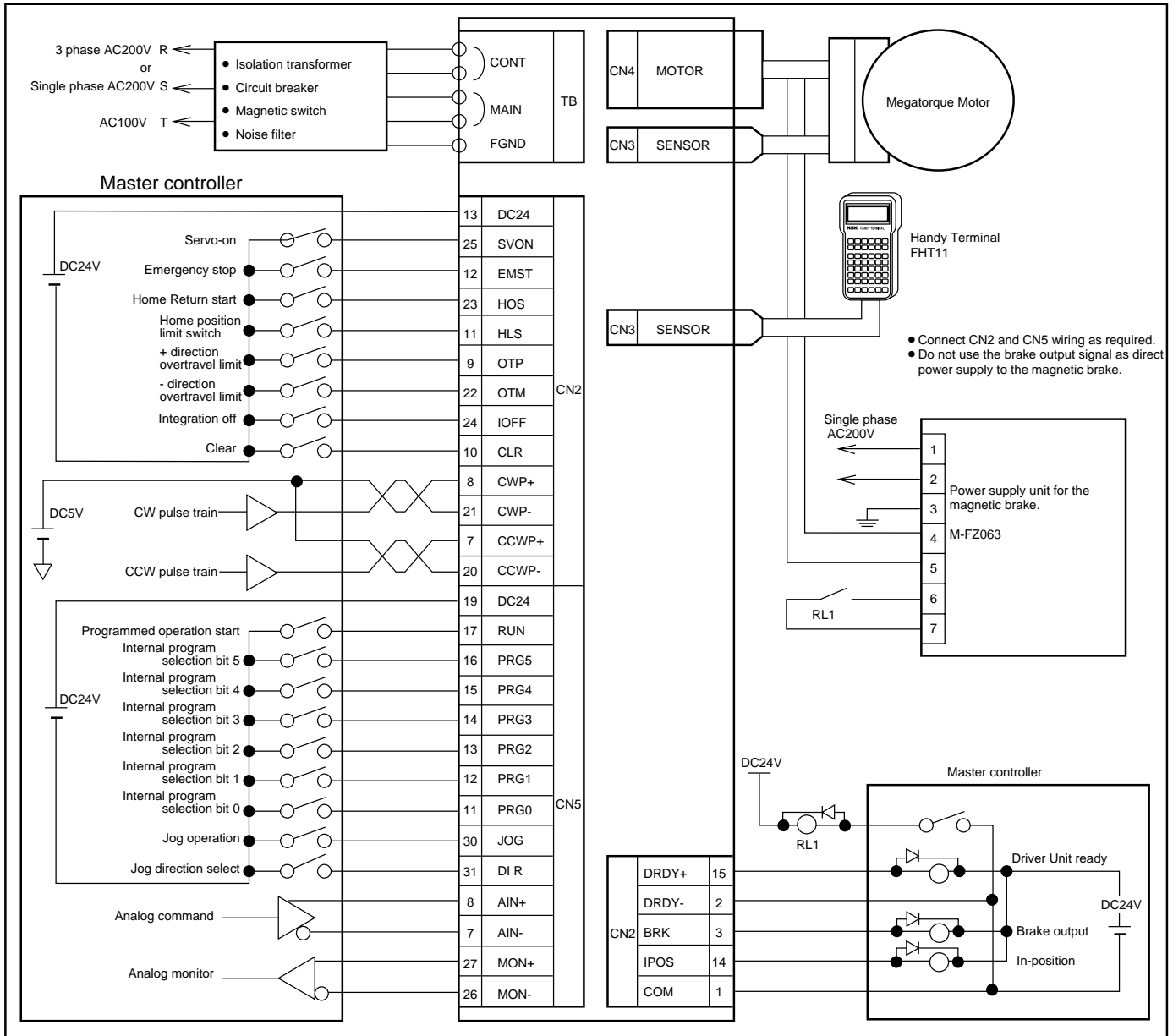

Table 4-16

Motor type	Brake type	Static friction torque (N·m)	Torsional rigidity (sec./N·m)	Brake releasing time (msec)	Brake engaging time (msec)	Capacity (W)
YS2020	RNB2K	20	4.5	26	10	17
YS3040	RNB4K	40	4.9	62	3	23
YS4080	RNB8K	80	1.3	66	5	30
YS5120	RNB12K	120	1.9	78	9	33

Figure 4-16 : Wiring example with brake



4.3. CN3: Resolver Cable Connector

- Since the resolver cable supplied with the Megatorque Motor System should always be used, you need only plug the resolver cable connector into CN3. Knowledge of the pin assignment or signal names is not necessary. This section is offered for reference.

Caution : • Do not change the length of the cable.

- Do not use other connector between the Resolver cable and CN3.

Danger : • Never connect pins not listed below.

- Insert the connector being careful of its orientation. Tighten the screws for fastening the connector so that it will not be loosened by shock.
- Never insert/remove the CN3 connector with the Driver Unit power turned on.

Table 4-17

Driver Unit connector	Japan Aviation Electronics Industry, Limited	DALC-J15SAF-13L9
Mating connector type	Japan Aviation Electronics Industry, Limited	DA-15P-N
Mating connector shell type	Japan Aviation Electronics Industry, Limited	DA-C1-J10

4.3.1. CN3 Pin-out

Figure 4-17: CN3 Pin-out

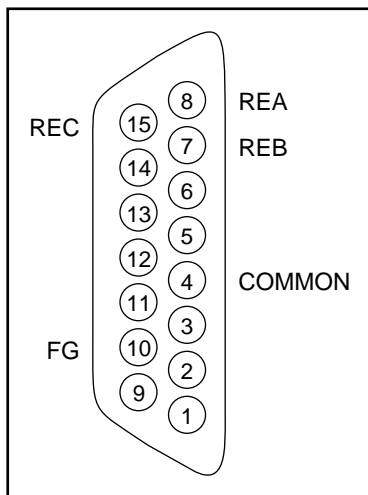

4.3.2. CN3 Signal List

Table 4-18: CN3 Signal List

Pin	Signal Name	Function
8	REA	Resolver signal phase A
7	REB	Resolver signal phase B
15	REC	Resolver signal phase C
4	COMMON	Common
10	FG	Frame ground

4.4. CN4: Motor Cable Connector

- Since the Motor cable supplied with the Megatorque Motor System should always be used, you need only plug the Motor cable connector into CN4. Knowledge of the pin assignment or signal name is not necessary. This section is offered for reference.

Caution : • Do not change the cable length.

- Do not use other connector between the Motor cable and CN4.

Danger : • Insert the connector being careful of its orientation. The connector is of a self-locking type. Insert the connector until it bottoms; otherwise, it will not lock.

- Never insert/remove the CN4 connector with the Driver Unit power turned on.

- A high voltage is applied to this connector after the power is turned on. Be very careful not to cause short-circuit.

Table 4-19

Driver Unit connector	AMP 172039-1
Mating connector type (user device side)	AMP 172495-1 (to be prepared by the user)
Mating connector shell type (user device side)	AMP 172774-1 (to be prepared by the user)

4.4.1. CN4 Pin-out

Figure 4-18: CN4 Pin-out

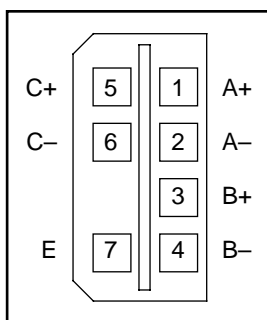

4.4.2. CN4 Signal List

Table 4-20: Signal Name and Function

Pin	Signal Name	Function
1	A+	Motor winding phase A (+)
2	A-	Motor winding phase A (-)
3	B+	Motor winding phase B (+)
4	B-	Motor winding phase B (-)
5	C+	Motor winding phase C (+)
6	C-	Motor winding phase C (-)
7	E	Motor grounding wire

4.5. TB: Terminal Block for Power Supply

4.5.1. Terminal List

Table 4-21: Terminal Labels and Functions

Terminal Label	Function
CONT	Control power input
MAIN	Main power input
FGND	Frame ground

4.5.2. Wiring Diagram (TB)

Figure 4-19: Wiring diagram (TB)

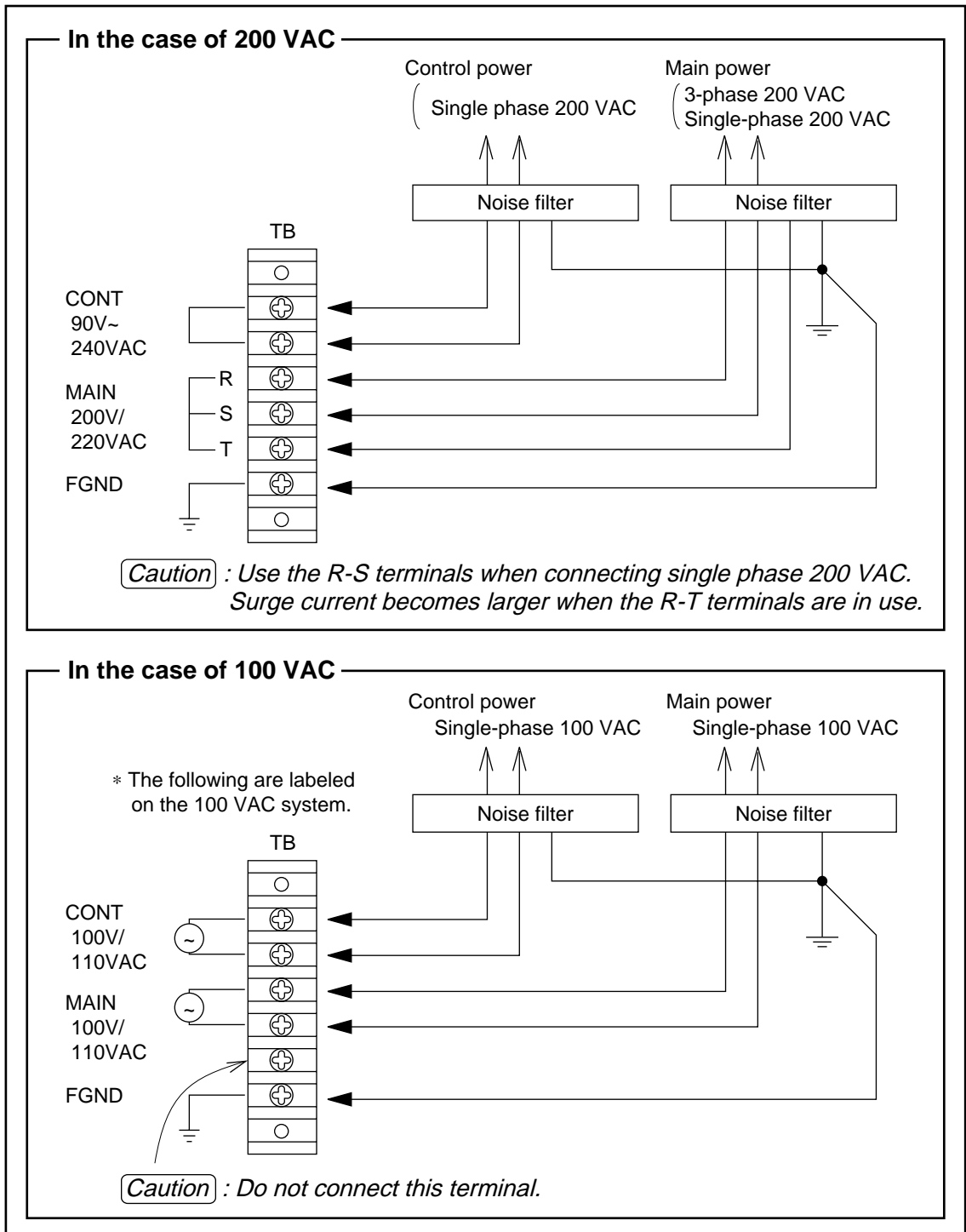

Additional Notes

- When the power is turned on, an inrush current will occur because the capacitive load is connected to the power supply. If circuit breaker and fuse are affected by the inrush current, install the inrush current control circuit to the power supply circuit as shown in the figures below.
- The inrush current varies with the source impedance. When an inrush current is over 300A, the Driver Unit may be damaged. We recommend to install the circuit to protect the Driver Unit.
- When the power is turned on in the inrush current control circuit, the current is being charged initially to a capacitor of the Driver Unit through R1 and R2 resistors for 9 ~ 20 msec, which is required time to close the contact of magnetic switch, and thus, the inrush current is reduced.
- When a magnet switch CR1 is failed (failed to contact), the resistor R1 may overheat and result in a fire. We recommend to take the countermeasures by installing the thermal sensor circuit to turn main power off.
- Example of circuit to reduce inrush current

Figure 4-20

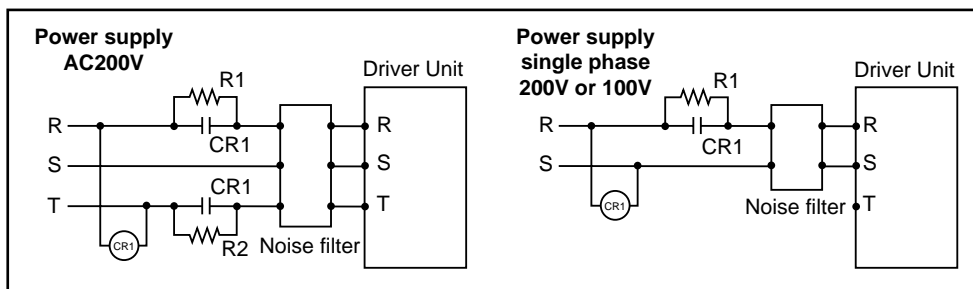

- Resistor R1 • R2 : Cement resistor 15 ~ 20W 10Ω
or ceramic resistor (Koa Ltd. HPC5 or equivalent)
- Magnetic switch CR1 : Contact point capacity 200V 20A or more
(SC-03 type or equivalent , recommended manufacturer; Fuji Electric)

- The optional “inrush current control circuit” is available. (Reference number M-FZ077)

[Checking Inrush Current]

Follow the instructions below to check the maximum inrush current.

- (1) Set the current probe to phase S of the Driver Unit power supply.
(Response frequency of the monitor shall be 10 K Hz or more.)
- (2) Inrush current shall be checked at the timing of A or B of the voltage wave form between phase R and S of power supply.
- (3) The maximum current reading of phase R just after the power supply is turned on is the inrush current.

Figure 4-21

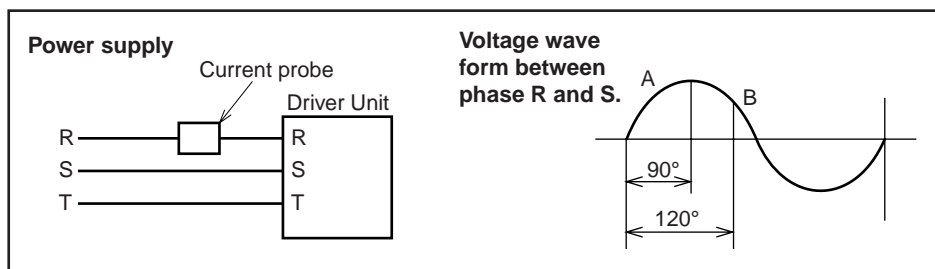

- When the dump resistor overheat alarm (Overheat 3: OH3) is detected, make sure to turn off the main power to protect the internal dump resistor from burning due to the defective Driver Unit or abnormal source voltage.

(Blank Page)

5. Unpacking, Installing, Wiring

5.1. Unpacking and Inspection

5.1.1. Unpacking

- Make sure that you have received following units.
 - ① Megatorque Motor
 - ② Driver Unit
 - ③ Cable Set (Motor Cable and Resolver Cable)
 - ④ Accessories
 - CN2 and CN5 control input/output signal connector
 - Fuse (2 sets)
 - These are packed with the Driver Unit.
- Inspect shipping containers for damage as an indication that the System might have been mishandled in transit.
- When unpacking the System, save all packing materials for reuse in the event that the System needs to be shipped or require service.

Danger : *Inspect the Motor and the Driver Unit very closely for damage which might have occurred in shipment. The Driver Unit is particularly fragile and should be inspected for warped or bent sheet metal, broken standoffs, and loose or damage electric components.*

- Rotate Motor's rotor by hand, without AC power. The rotation should be smooth.
- If you suspect damage, do not apply power to the System, since this can cause immediate catastrophic damage to the Driver Unit. Furthermore, a damaged system could be a potential electric shock hazard. Notify the carrier immediately, and call your NSK representative.

5.1.2. Motor and Driver Unit Combination

Caution : Make sure that the combination of Motor and Driver Unit conforms to your requirements.

Check and record the Motor and Driver Unit reference number and serial number.

- Standard Combination
 - The Motor series, size and maximum torque numbers in both Motor and Driver Unit reference number must be same.
- Special-order Combination
 - Refer to the respective specification document.
- Even when the Motor and Driver Unit are in an interchangeable combination, check reference number in same manner as Standard combination. If the combination is not interchangeable, serial numbers of Motor and Driver Unit must be same.
- A nameplate is attached to individual Motor and Driver Unit. Configuration of each plates are shown in Figure 5-1. Refer to “2.2. Reference Number Configuration” for the more details.

Figure 5-1

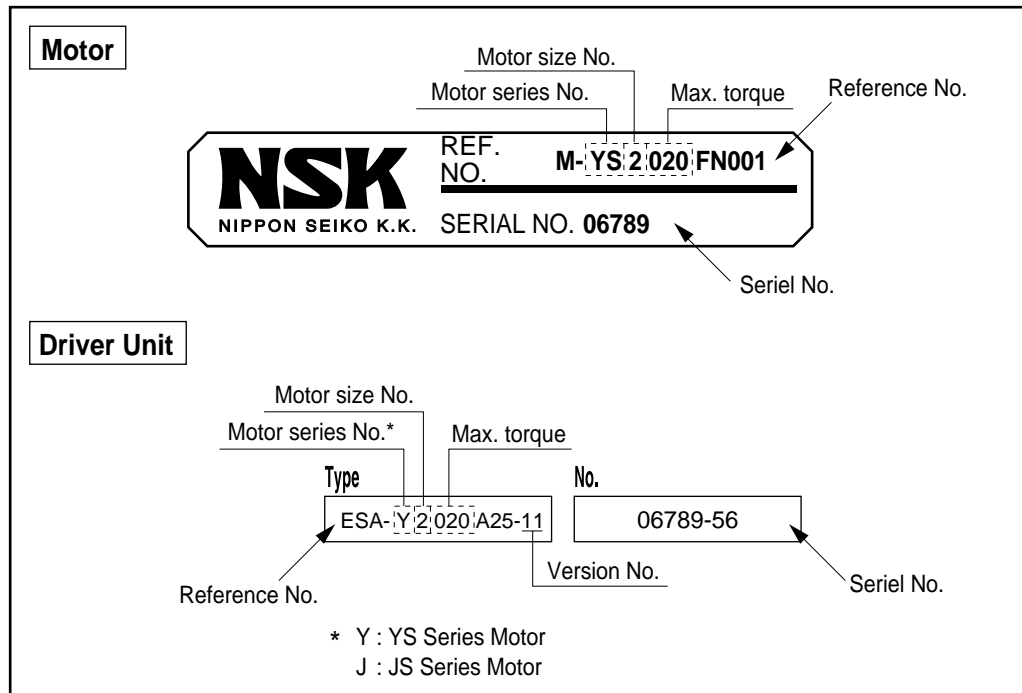

5.2. Installation

5.2.1. Motor

5.2.1.1. Motor Mounting

- The high acceleration/deceleration characteristic of a direct drive mechanism requires the system to have high mechanical rigidity. Therefore, it is essential to maximize rigidity of the Motor and the load system.
- The Motor will work best if all of the elements have a natural frequency between them of at least 100 Hz, and preferably more than 200 Hz.

Warning : • Fully fasten all the mounting holes (mounting tap holes) of the Motor.

- Fasten a load using all of the tapped holes of the rotor.
- Eliminate play between the load and the rotor.
- Eliminate play in the mechanism as much as possible.

Warning : The flatness of the surface where the Motor is mounted affects Motor operation. Approximately less than 0.02 mm flatness is needed for smooth operation. When mounting, minimize the looseness between Motor and the mounting surface.

Figure 5-2: Motor Mounting

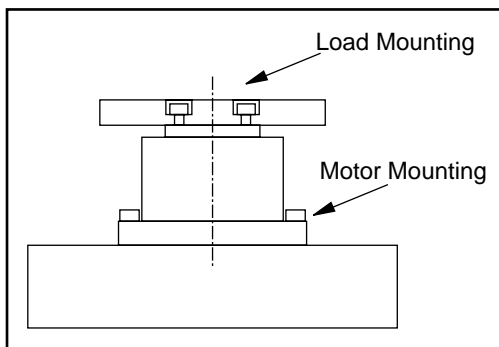

5.2.1.2. Load Inertia

- Generally, the load inertia is much bigger than the rotor inertia of the Motor. Table 5-1 shows the approximate inertia capacity of Motor. (Inertia is shown as J in kgm².)

Table 5-1: Inertia capacity

(Unit: kgm²)

	High speed positioning	General use	Large inertia (Low speed positioning)
YS2005	0.006 ~ 0.25	0.25 ~ 0.5	–
YS2020	0.025 ~ 1	1 ~ 2	–
YS3008	0.01 ~ 0.4	0.4 ~ 0.8	–
YS3040	0.05 ~ 2	2 ~ 4	–
YS4080	0.1 ~ 4	4 ~ 8	–
YS5120	0.15 ~ 6	6 ~ 12	12 ~ 30
YS5240	0.3 ~ 12	12 ~ 24	24 ~ 125
JS0002	0.003 ~ 0.1	0.1 ~ 0.2	–
JS1003	0.004 ~ 0.15	0.15 ~ 0.3	–
JS2006	0.008 ~ 0.3	0.3 ~ 0.6	–
JS2014	0.018 ~ 0.7	0.7 ~ 1.4	–

Caution : Make sure that the actual moment load and thrust load are less than the allowable load capacity. Refer to YS and JS Motor specifications.

5.2.2. Driver Unit Mounting

Caution : Cooling the Driver Unit relies on natural convection. For proper air circulation, clearance is required above and below the Unit (see Figure 5-3).

- Clearance is not necessary in the back of the Unit.

Caution : When installing two or more Driver Unit for multi-axis combination, give a space approximately 10 cm between adjacent Driver Unit.

- When installing the Driver Unit in the control panel , keep the panel internal temperature from 0 °C to 50 °C. If the heat sink over-heat alarm arises frequently, cool the heat sink using a fan etc.
- ESA25 Driver Unit has a bracket for easy fixing to the control panel or enclosure.

Figure 5-3

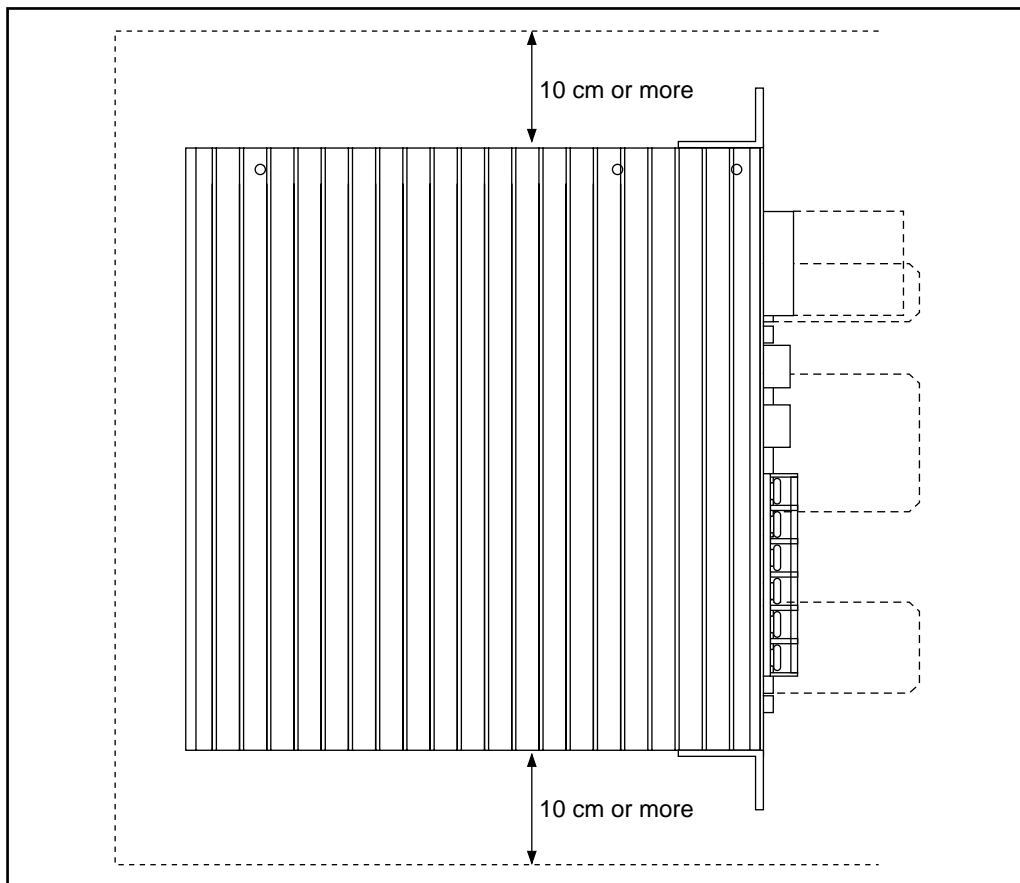

- Maximum power dissipation of ESA25 Driver Unit is 100W.

5.3. Wiring

5.3.1. Connecting Motor and Driver Unit

Caution : Do not make the Cable Set length longer or shorter. Changing cable length may worsen Motor and Driver Unit performances, typically resolver and resolver repeatability. When changing the length, the Motor and the Driver Unit must be returned to the manufacturer. Contact your local NSK representative.

Caution : Do not place the power lines (AC power supply and Motor cable) and the signal lines (CN2 and Resolver cable) in close proximity. Do not tie wrap them and not put in the same duct.

Figure 5-4: YS Motor

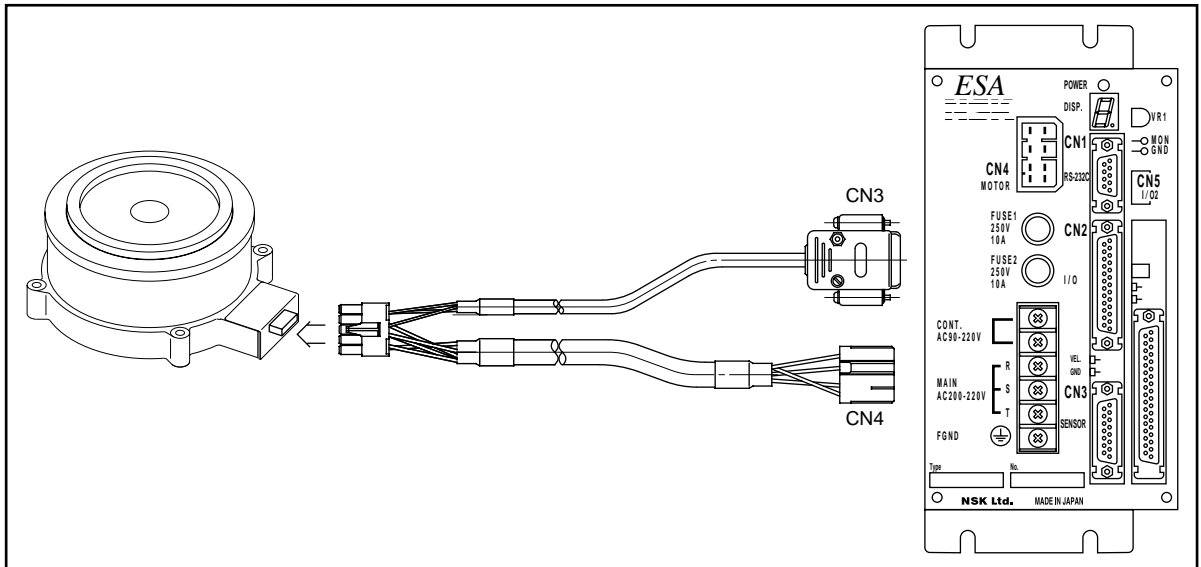
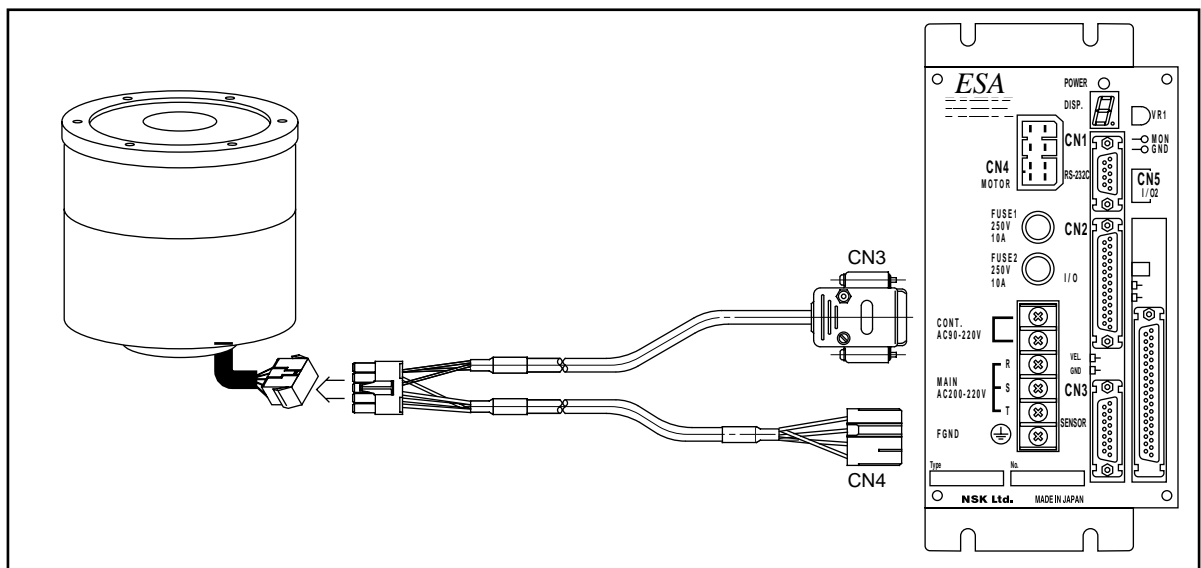

Figure 5-5: JS Motor



5.3.2. Connecting Power

- Refer to “4.5. TB: Terminal Block of Power Supply.”
- Use 2.0 mm² or larger wire with heat-proof vinyl for power line.
- Do not place the main power AC line supplies and signal wires in close proximity. Do not tie wrap them and not to put in a same duct.
- The noise filter and the isolation transformer must be installed between main power supply and the Driver Unit for the protection from electrical noise.

Table 5-2

Driver Unit AC Line	Noise Filter Voltage Rating	Current Rating
220VAC, 3ø	250V AC/DC	15A AC/DC
220VAC, 1ø		
110VAC, 1ø		
Control Power	250V AC/DC	5A AC/DC

- The primary and secondary wires of a noise filter and an isolation transformer must not be in close proximity. Do not put them in a same duct.
- The Driver Unit and the noise filters must be close to each other and wiring must be of minimal length. Do not insert contacts like a magnetic switch and relay between them as much as possible.
- Install a surge killer circuit for magnetic switches, relays and solenoids.
- When the main power is turned on, an inrush current to the circuit will arise due to the capacitive load connected to the main power supply circuit. Use contacts, like a magnetic switch and a relay, which have a enough capacity shown in Table 5-3 and Table 5-4.

Table 5-3: Contact requirements

Contacts	For ESA25 Type
No-Fuse Breaker	Current Rating 15A
Short-Circuit Breaker	Contact Capacity 15A Sensitivity 15mA
Magnetic Switch	Contact Capacity 30A

Table 5-4: Inrush-current

Item	Inrush Current (TYP)	
	AC100v	AC200V
Control Power	7A	14A
Main Power	80A	140A

Caution : • Use the R-S terminals when connecting single-phase 200 VAC for the main power supply. Surge current becomes larger when the R-T terminals are in use.

- During wiring, be careful not to loose terminal block screws.

5.3.3. Connector Wiring

- Refer to “4. Connector Specification.”

5.3.4. Ground Connection and Wiring

- For grounding Driver Unit, use heavy gage cable as possible, such as a flat braided copper cable or a wire 3.5mm² (AWG 10) or larger.

Warning : All the ground lines must be connected at one point and the line resistance must be under or equal to 100Ω.

Caution : • Connect the shield of the signal shielded cable (CN2) to the FG terminals (or SG terminals) of the user’s controller. If runaways are caused by noise, connect the shield to the FG terminal of the Driver Unit.

- If the Motor is isolated from the mother machine, then ground the Motor separately.

- Figure 5-6 shows the wiring example. (This is provided as an example, not the instruction.)

Figure 5-6: Ground wiring example

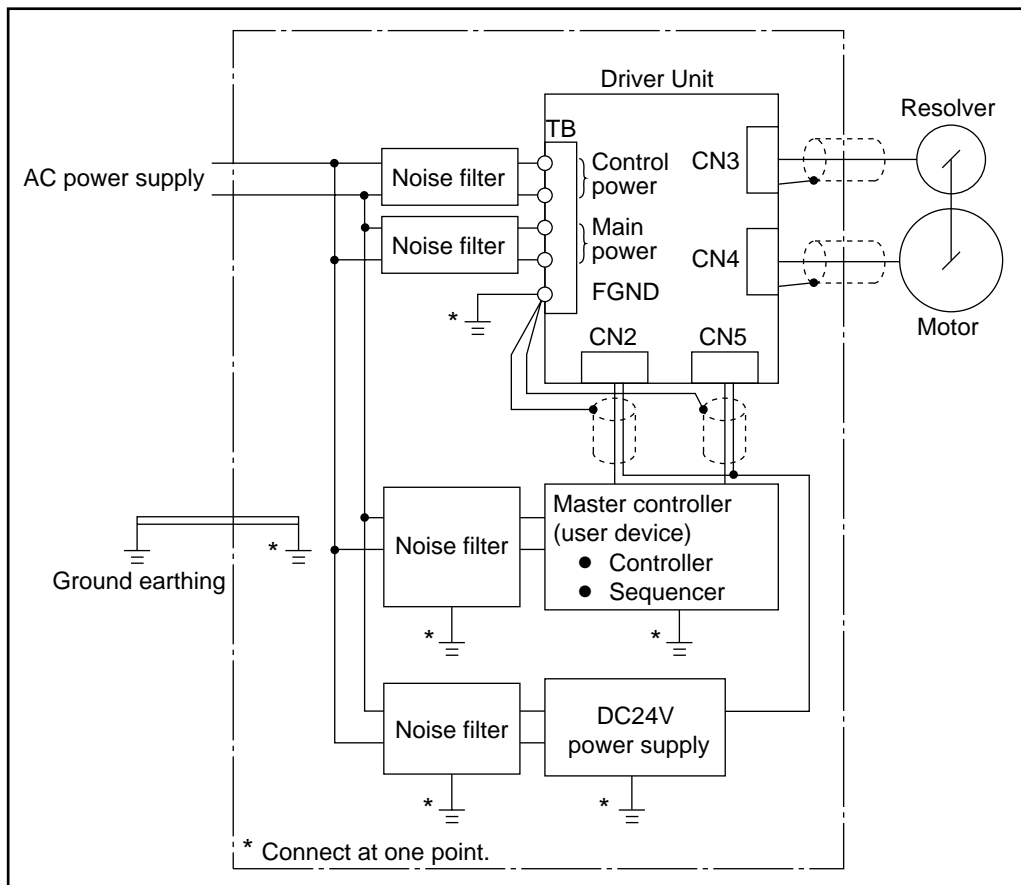

5.4. Turning on Power

5.4.1. Precautions

Caution : Before turning on the main power, check the following.

- (1) Wiring of connectors
- (2) Connecting Cable of Motor and Driver unit.
- (3) Safety
- (4) A wrong connection may damage the Driver Unit.

Danger : Always stay in a safe place.

Warning : Confirm that the Motor is securely fixed to the mounting base and the load is fixed to the Motor. Fully fasten all the mounting bolts.

Danger : If the Motor is fitted with an arm or a work, make sure that no obstacles are around in the operating area.

5.4.2. Turning Power on

- (1) Turn on the power
- (2) Make sure that the LED of the Driver Unit and the Handy Terminal display are indicating that the system is ready for operation.
 - ① Normal state
 - Figure 5-7 shows the LED indicator in normal condition.

Figure 5-7

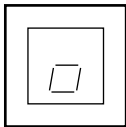

② Abnormal

Figure 5-8

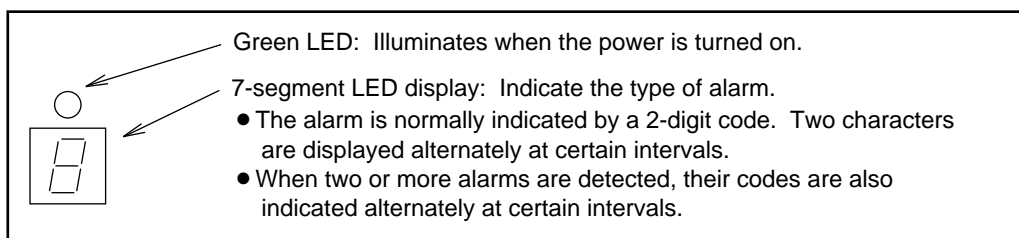

○ Refer to “ 13. Alarms” for the description of alarms.

③ Handy Terminal display

Figure 5-9: Handy Terminal display in normal state

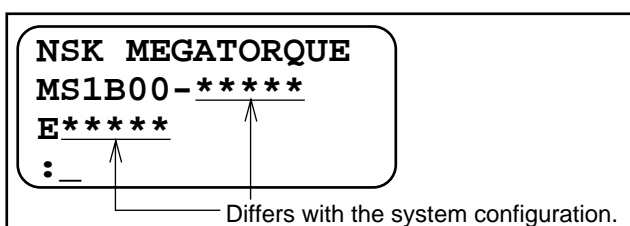

○ If a message “NSK MEGA....” is displayed on the Handy Terminal, the system is ready for operation. A colon (:) indicates that a command be entered.

5.4.3. Servo On

- (1) Turn main power on.
- (2) Check DRDY output 2 seconds after the power is on.
- (3) If the system is normal, input SVON signal.
- (4) Then input necessary commands.
 - If an alarm is detected, refer to “13. Alarms” and take a proper remedy.

Figure 5-10 : Power “ON” sequence

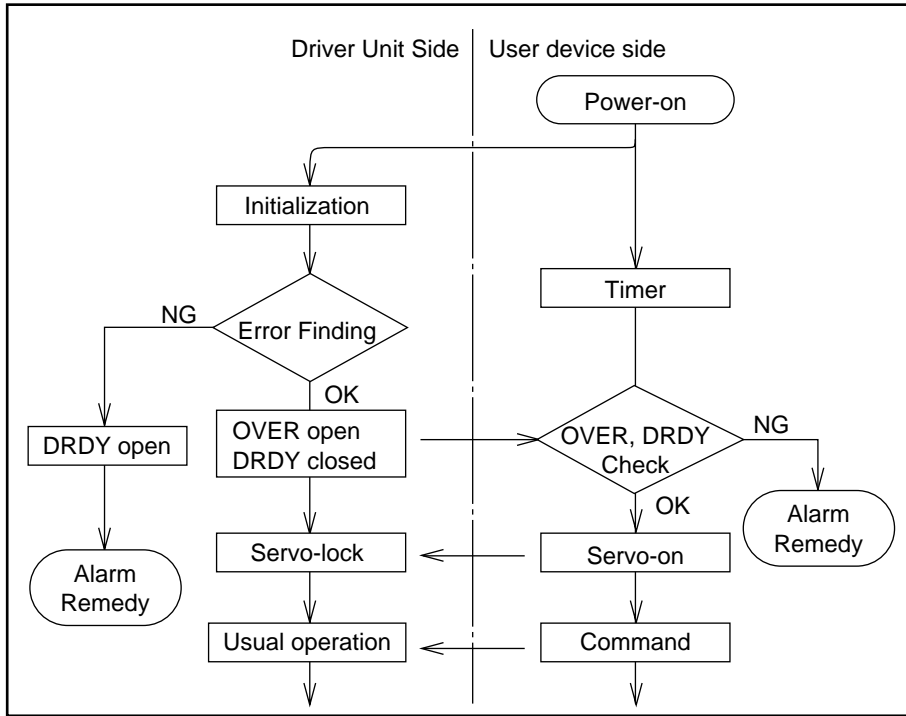
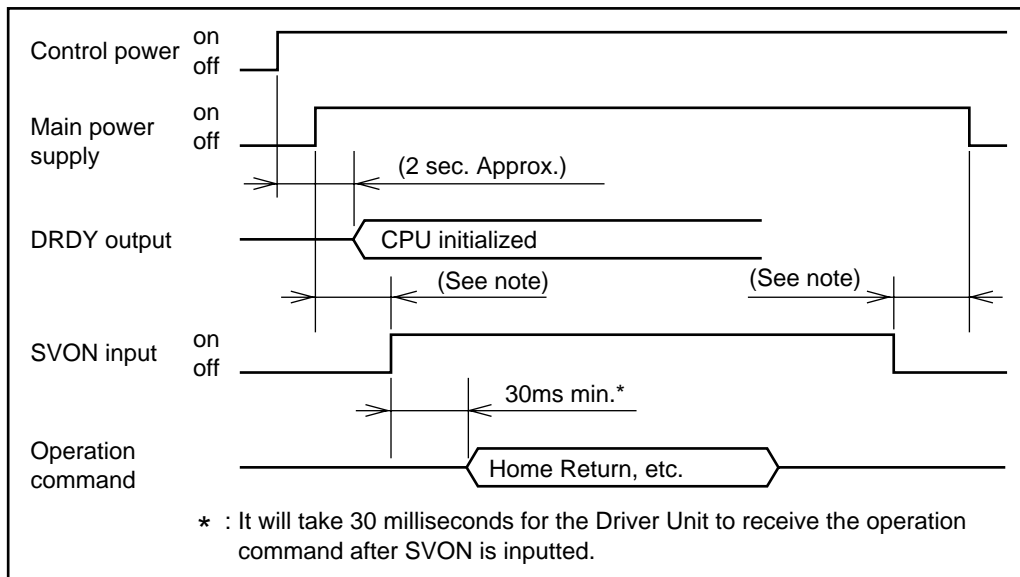

Figure 5-11 : Power ON / SVON timing



Caution : Turn on the main power supply first, then the SVON input, when turn off the main power supply, turn off SVON first. If the main power supply is turned off in the servo-on state, the Driver Unit outputs the AC Line under-voltage alarm. Once this alarm occurs it will not recover unless the power is turned on again.

6. Handy Terminal Communication

- Setting of various parameters, trial running, and adjustment are enabled by issuing commands to the Driver Units through NSK Handy Terminal FHT11. (i.e., communication through the RS-232C interface).
- The Driver Unit has CN1 as the Input/Output ports for RS-232C communication.
- FHT11 Terminal can be a daisy chain communication terminal. Refer to “8.3.4. Daisy Chain Communication” for details.

Caution : Always turn off the Driver Unit when plugging on/off the CN1 connector.

- Turn off the Driver Unit, if it has been turned on.
- Connect FHT11 and the Driver Unit at connector CN1.
- The communication will automatically begin when you turn on the control power of the Driver Unit.

6.1. When Power is Turned on

- If the terminal (NSK Handy Terminal FHT11) is connected to CN1 and the Driver Unit power is turned on, the message shown below is displayed.
- The contents (and the number of characters) of this message may differ with Driver Unit setting and system versions.
- When the Driver Units are initialized, a colon (:) is displayed and the system waits for a command to be entered. The colon (:) is called a prompt. If the colon (:) is not displayed, press **ENT** key.

Figure 6-1: Power-On Message

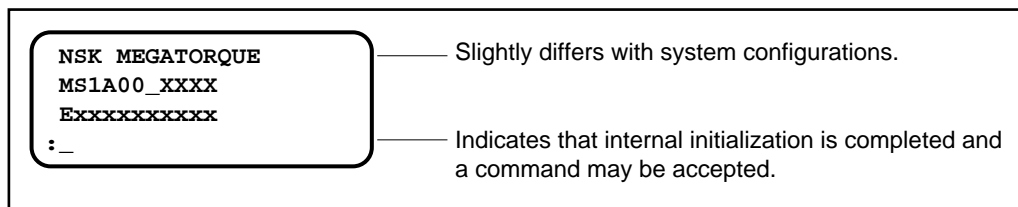

6.2. Command Entry

- Refer to “3.4. Handy Terminal” for the function of the keys.
- Communication command shall consist of “a command (character string) + data (if necessary) + **ENT**”
- If the velocity gain is to be set to 0.5, for example, “VG0.5” should be entered by adding data of 0.5 to a VG command.
- Every time a character is input, the Driver Unit echoes the character back to the terminal. (The Driver Unit returns same character it receives.)
- When **ENT** code is input, the Driver Unit decodes a character string which it has received (VG0.5 in the example above) and executes it. Therefore, a command is not executed unless it ends with **ENT**.

Caution : When turn off the Driver Unit power, make sure that a colon (:) is displayed. If not, an alarm “Memory error” might be detected when you turn on the power next time.

6.2.1. Password

- Among the communication commands used for this System, some special commands (such as AB, PA, SI, etc.) require password entry for preventing erroneous entries. These commands cannot be entered in the same manner as other commands.
- The password is /NSK ON (a space between K and O) as shown below. If the Driver Unit accepts it, it returns an “NSK ON” message. Refer to “11. Command and Parameter” for details.
- A command requiring password entry may only be executed immediately after the password is entered.

Figure 6-2: Password Input

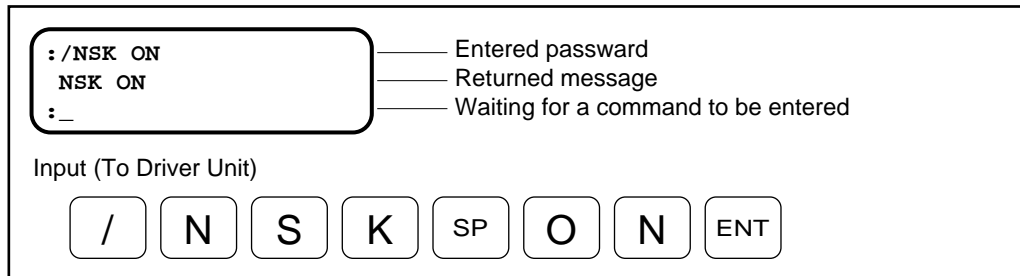

6.2.2. Canceling Command

- To cancel a command which has been entered halfway, enter a backspace code.
- For example, when the backspace code is input following VG0.5, the cursor moves one space back to the position where 5 was input and thereby deletes 5.

Figure 6-3: Canceling Example

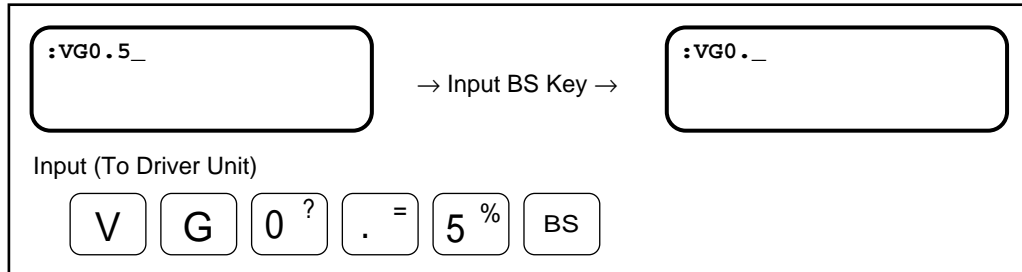

6.2.3. Error

- Note that an error occurs in any of the following cases:
 - (1) If a nonexistent command (i.e., character string) is entered (If an entered character string cannot be decoded).
 - (2) If data or subscript out of the allowable range is entered.
 - (3) If a command requiring the password is entered without the password.
- In any of these cases, the entered character string with a '?' mark is returned as an error message.

For example,

Figure 6-4: Input Error Example 1

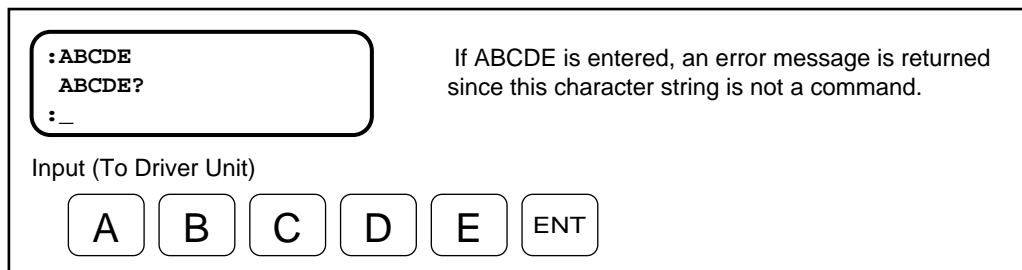

6.2.4. Entering Parameter

- (1) When entering parameter, make sure that a colon (:) is displayed on the screen.
(If the colon is not displayed, press the enter key once.)



- (2) As an example, set the parameter “Move Velocity MV” (revolution speed) to 0.5 r.p.s.
Enter the parameter as shown below.

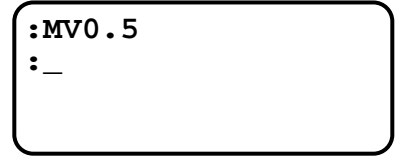
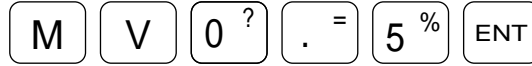

The colon (:) appears to confirm the entry.

- As shown above, inputting “the parameter command + numeric value + **ENT** key” completes the parameter entry. (Entering the space key between the parameter and numeric values is not necessary.)

6.2.5. Entering Parameter Requiring Entry of Password

- (1) When entering parameter, make sure that a colon (:) is displayed on the screen.
(If the colon is not displayed, press the enter key once.)



- (2) Enter the password referring to “6.2.1. Password.”

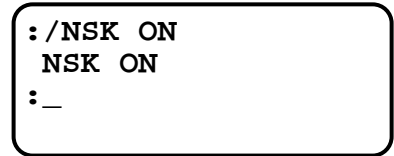
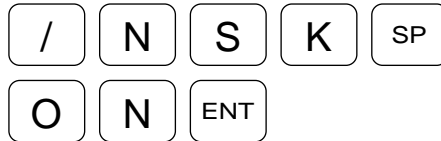

The message confirming the entry of password is displayed and the colon (:) appears on the screen.

- (3) Enter the parameter as described in “6.2.4. Entering Parameter” above.
The parameter entry requiring password may only be executed immediately after the password is inputted.

6.3. Readout Command

- If a command for reading initial setting or current state is entered, the Driver Unit returns data.
- The following is an example for checking “Jog Velocity JV” set value.

6.3.1. “TS” Command for Reading Set Value

- (1) When entering the command, make sure that a colon (:) is displayed on the screen.
(If the colon is not displayed, press the enter key once.)

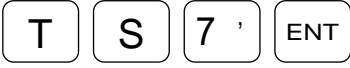

- (2) Refer to “11. Command and Parameter TS”. “JV” command is in the group of TS7, input

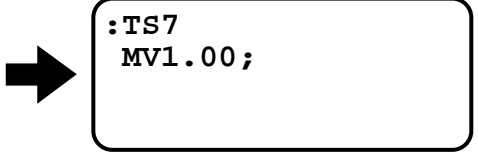

The setting value of MV (Move Velocity) is displayed first.

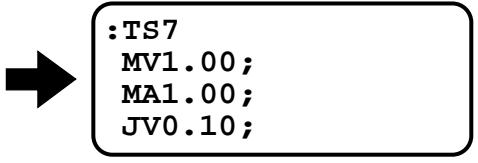
- (3) Press the space key to scroll display to find out JV value.

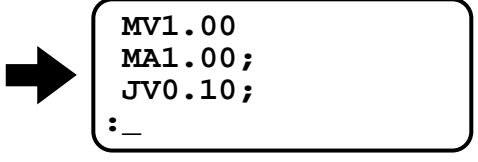

- (4) To finish the read out, keep pressing the space key until display stops scrolling or press the back space key.



- (5) The colon (:) is displayed to indicate the system is waiting for next command.

6.3.2. “ ? ” Reading Function Command for Set Value

- (1) When entering the command, make sure that a colon (:) is displayed on the screen.
(If the colon is not displayed, press the enter key once.)



```
:_
```

- (2) Enter “ ? ” before inputting the command.
In case of this example, input “JV” after “ ? ”.



```
:?JV  
JV0.10  
:_
```

- (3) The colon (:) is displayed to indicate the system is waiting for next command.

Caution : When reading out set value, using TS command is recommended.

When using “?” command, make sure to input “?” command before parameter characters. If not, and pressing key after the characters may change the set value.

7. Tuning and Trial Running

- Gain adjustment is necessary for the position control mode and the velocity control mode.
- In the torque control mode, the noise filter adjustment may be required.

7.1. Tuning Sequence

Figure 7-1: Tuning Sequence

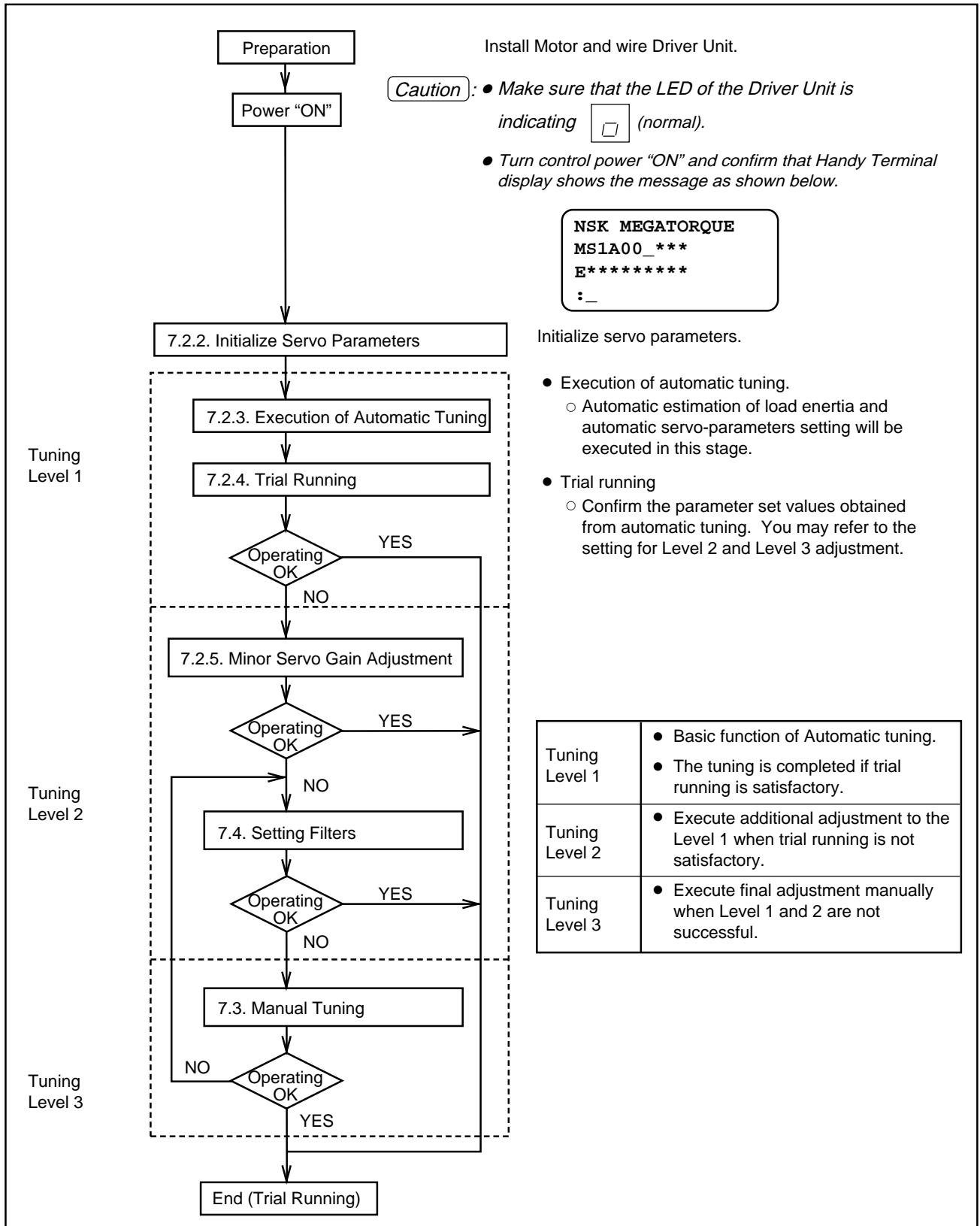

7.2. Automatic Tuning

Caution : Automatic tuning cannot be performed if the following conditions are not met.

- The load inertia must be under the limit of the Motor. (Refer to “3.1. Motor Specification”)
- The Motor axis must be vertical. (The load conditions to the Motor must not be affected by the gravity.)
- Mechanical rigidity of the Motor mounting base and attached load is sufficient enough.
- There must be no backlash or play caused by gears and couplings.
- Frictional load to the Motor shall be minimal.

7.2.1. Precautions

Danger : ● Wire “EMST” (Emergency Stop, CN2) signal to stop the Motor immediately when an accident is foreseen.

● If the Motor rotation range is restricted, set overtravel limits (OTP, OTM).

● The Motor rotates $\pm 20^\circ$ (degree) when executing automatic tuning. Always stay in safe position.

Caution : If mechanical rigidity of the load (work) is not sufficient enough, the Motor may vibrate. Turn “SVON” signal off or turn off the power when the Motor starts to vibrate. Execute manual tuning in chapter 7.3 or increase the rigidity of the load.

Caution : The automatic tuning is valid in the position control mode and the velocity control mode. It is not necessary for the torque control mode.

Figure 7-2: Wiring Diagram Example of Automatic Tuning Preparation

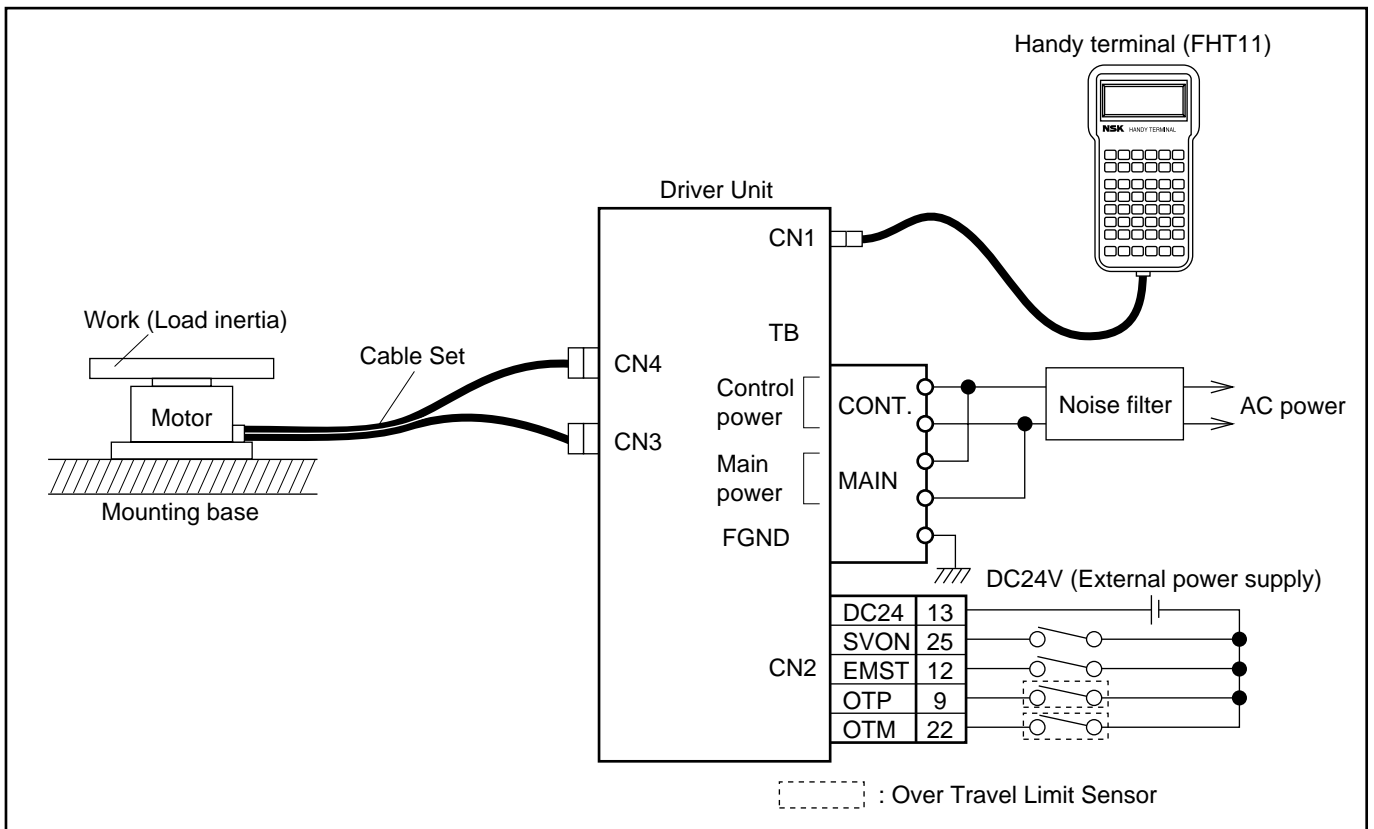

7.2.2. Initialize Servo Parameters

(1) Turn off the servo-on (SVON, CN2) signal.

(2) Enter **T S 1 # ENT** and **T S 2 \$ ENT**

to check the parameter settings. Note down all values.

(3) Log in the password.

/ N S K SP
O N ENT



: /NSK ON
NSK ON
: _

Display indicates the confirmation.

(4) Log in SI (Set Initial Parameters) command.

S I ENT



: SI
INITIALIZE
: _

“INITIALIZE” is displayed as the confirmation, and the initializing parameter begins. It takes few seconds and a colon “:” is displayed for next command.

Caution : When “SVON” signal (CN2) is “ON” and “SI” command is input, Driver Unit rejects to execute the command. “SI INHIBITED” message will appear in the display.



: SI
SI INHIBITED
: _

Table 7-1: Servo Parameter List

Parameter	TS1 Reading		Parameter	TS2 Reading	
	Initial Setting	Set Value		Initial Setting	Set Value
PG	0.100		FO*	0.000	
VG	1.0		FP	0	
VI	1.00		FS	0	
VM	1		NP	0	
LG*	50		DBP*	0	
TL*	100		ILV*	100	
			FF*	0.000	
			FC*	0	

* These parameters are not necessary to adjust in Level 1 and 2 adjustment.

7.2.3. Execution of Automatic Tuning (Tuning Level 1)

Caution : Make sure the work (or Motor) does not hit any obstacle when the Motor makes a full turn. Always stay in safe position.

- The Motor needs to rotate at least $\pm 20^\circ$ when executing the automatic tuning. If the application restricts the Motor rotation, keep room for $\pm 20^\circ$ Motor rotation. The overtravel limits (OTP, OTM) must be used to restrict the Motor rotation range.

(1) Turn SVON (CN2) signal “ON” and inputting “SV” command makes the Motor in servo-on states.

S
V
ENT

➔

```
:SV
:_
```

(2) Confirm that Driver Unit’s “LED” is indicating “” for normal condition.

(3) Input “Automatic Tuning” command.

A
T
ENT

➔

```
:AT
AT ready OK
?_
```

If a message is different from the display shown right, try procedures (1) and (2) again.

(4) Confirm the message “AT ready OK” then input “OK”.

O
K
ENT

➔

```
:AT
AT ready OK
?OK
...
```

The Motor rotates 10~20° back and forth to estimate the load inertia. When executing estimation, a dot (.) keeps appearing in the display till the Motor stops.

(5) After the estimation of load inertia, the display indicates the inertia value “LO”.
(Way of displaying “.” and the value of LO differ with the condition of load inertia.)

➔

```
?OK
.....
LO****
:_
```

Load inertia estimation.

Caution : When executing the automatic tuning, if an error message is “ON”, refer to “13. Alarm” and take a proper remedy. Driver Unit’s LED indicates “F8” for “AT” error in an example display shown right.

➔

```
?OK
.....
AT Error1*
:_
```

Error number

7.2.4. Trial Running (Tuning Level 1)

Danger : Confirm that the work (or Motor) does not hit any obstacle when the Motor makes a full turn. Always stay in safe position.

- For this adjustment, ESA25 Driver Unit's demonstration program is used as an example. The program is originally set before it is shipped.

- (1) Turn SVON (CN2) signal "ON" and inputting "SV" command makes the Motor in servo-on states.

S **V** **ENT**



```
:SV
:_
```

- (2) Confirm that Driver Unit's "LED" is indicating "" for normal condition.

- (3) Confirm an emergency stop (ESTM) and over travel limits (OTP, OTM) are "OFF".

- (4) After the automatic tuning the rotational speed "MV" has been initialized to 1 rps. Change "MV" to 0.1 rps for trial running.

M **V** **0** **?** **.** **=** **1** **#** **ENT**



```
:MV0.1
:_
```

Note : After the adjustment, change "MV" to the actual use.

- (5) Display the demonstration program.

S **P** **/** **A** **J** **ENT**



```
:SP/AJ
IN100,IS0.0,FW1.0
ID9000/OK
?_
```

The message indicates the conditions of positioning and rotation angle.

IN: In-position, IS: In-position stability timer.

FW: FIN Width.

ID: Incremental Positioning, Degree.

(Refer to "11. Command and Parameter")

- (6) To make the adjustment simple, set IN "10" (pulse) and IS "50" (m sec).

I **N** **1** **#** **0** **?** **ENT**

I **S** **0** **?** **.** **=** **5** **%** **ENT**



```
?IS0.5
IN10,IS0.5,FW1.0
ID9000/OK
?_
```

Check the display for confirmation.

- (7) When rotational angle (ID) 9000 (90 degrees) is feasible, input "OK".



```
IN10,IS0.5,FW1.0
ID9000/OK
?OK
: _
```

The motor starts the cycles as soon as "OK" is logged in.
(Firstly the Motor rotates clockwise (CW).)

For changing rotational angle (ID) while "?" prompt is displayed, input desired ID, then input "OK".

[Example for rotational angle: 30° (degree)]



```
?ID3000
IN10,IS0.5,FW1.0
ID3000/OK
? _
```

- (8) When the trial running is completed, type



```
:MS
: _
```

to stop the Motor.

- If the Motor is operating satisfactorily, complete the trial running.
- When the Motor operation is not stable, try further adjustment in chapter 7.2.5 and 7.3.
- If you want to get out from the demonstration program, press the enter key after "?".

7.2.5. Servo Gain Minor Adjustment (Tuning Level 2)

Danger : Confirm that the work (or Motor) does not hit any obstacle when the Motor makes a full turn. Always stay in safe position.

- This section describes minor servo-gain adjustment as the next step when the Motor operation is not satisfactory with the automatic tuning.
- Servo-gain can be adjusted by the parameter “SG”.
 - Setting higher “SG” value improves response to the programmed motion profile. However, if “SG” is too high, the Motor starts to vibrate.
- The same demonstration program in chapter 7.2.4 is used as the example for adjusting “SG” value. (Execute same procedure (1) ~ (7) in chapter 7.2.4 and keep operate the Motor.)

(1) Start “SG” adjusting program.

S G / A J ENT

The message is displayed as shown below. Press plus (+) or minus (key) to change “SG” value. (The display shown below is an example. Those values shall be set to the conditions for actual use.)

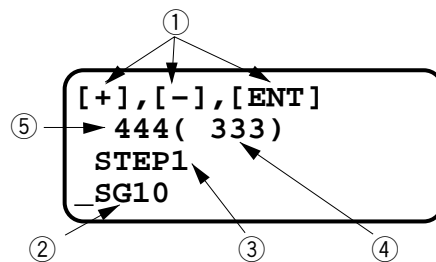

● Explanation of the messages

① Key function

SHIFT and $\text{—} \text{+}$: Pressing key one time increases 1 resolution of “SG”.

$\text{—} \text{+}$: Pressing key one time decreases 1 resolution of “SG”.

ENT : Store “SG” value to the memory.

② Indicates present “SG” value.

③ Indicates “SG” value changed by pressing plus (+) or minus (–) key.

④ Response index number: The lower numbers denotes better response.

⑤ Positioning index number: The lower number denotes quicker response.

Note: Do not use space key or back space key. When it is used, the “SG” changing resolution (③) may be altered.

- (2) Observing the Motor operation, press the plus (+) key several times.

Pressing ,     ...

As the response index decreases, the movement of the Motor is getting crisply.



```
[+],[-],[ENT]
333( 222)
STEP1
_SG13
```

- (3) Keep pressing the plus (+) key, eventually the Motor starts hunting and stops.

Pressing ,   ...



```
[+],[-],[ENT]
233( 123)
STEP1
_SG18
```

- (4) Keep pressing the minus (-) key until the Motor stops hunting and starts moving.

    ...



```
[+],[-],[ENT]
253( 145)
STEP1
_SG16
```

- (5) Set "SG" value 80% of "SG" value at when the Motor stopped hunting. The Motor operates stable in any position.



```
[+],[-],[ENT]
263( 156)
STEP1
_SG13
```

- (6) Type the enter key to complete the adjustment.





```
263( 156)
STEP1
SG13
:_
```

7.3. Manual Tuning

Danger : Confirm that the work (or Motor) does not hit any obstacle when the Motor makes a full turn. Always stay in safe position.

- Manual tuning is needed when the automatic tuning did not work.

7.3.1. Precautions

- ① Initialize servo parameters. Follow procedures in “7.2.2. Initialize Servo Parameters”.
- ② Execute the demonstration program referring to “7.2.4. Trial Running (Tuning Level 1)”. At the beginning, Motor operation is unstable due to insufficient tuning.

7.3.2. Adjustment of the Velocity Gain (VG)

- (1) Start “VG” adjusting program.

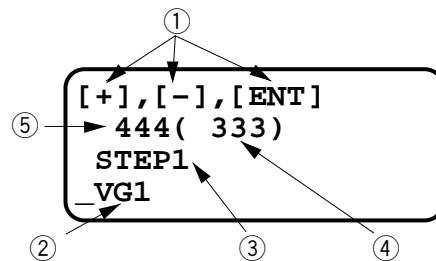

- The display shows the message as shown on the left.

- Explanation of the messages

- ① Key function

SHIFT and **- +** : Pressing key one time increases 1 resolution of “VG”.

- + : Pressing key one time decreases 1 resolution of “VG”.

ENT : Store “VG” value in the memory and completes the adjustment..

② Indicates present “VG” value.

③ Indicates “VG” value changed by pressing plus (+) or minus (-) key.

④ Response index number: The lower number denotes better response.













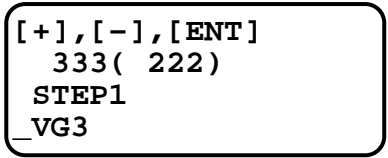

⑤ Positioning index number: The lower number denotes quicker positioning.

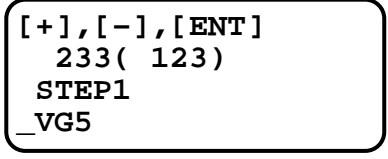
Note: Changing “VG” step (③).

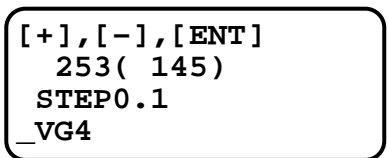
If you want to change the resolution of step, press space key or back space key.

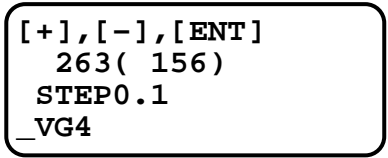
Space key : Changes the step to 1/10 of present resolution.
(Pressing twice makes 1/100.)

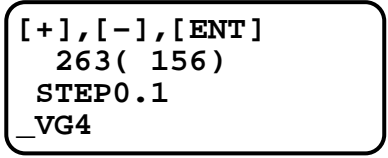
Back space key : Changes the step to 10 times of present resolution.
(Pressing twice makes 100 times.)

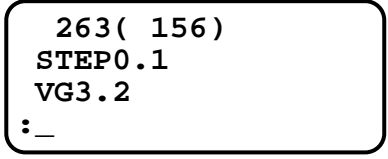
- (2) Observing the Motor operation, press the plus (+) key several times.
- Pressing ,  +  ...
- As the response index decreases, the movement of the Motor is getting crisply.
- 
- (3) Keep pressing the plus (+) key, eventually the Motor starts hunting and stops.
- Pressing ,  +  ...
- 
- (4) Keep pressing the minus (-) key until the Motor stops hunting and starts moving.
-  +  ...
- 
- (5) Set the “VG” value to 80% of displayed “VG” when a hunting is stopped.
 $4 \times 0.8 = 3.2$
- (6) Press the space key to change the resolution of “VG” setting value from 1.0 to 0.1.
- 
- 
- (7) Press the minus key till “VG” value reaches to 3.2.
-  +  ...
- 
- (8) Press the enter key to store the “VG” value.
- 
- A colon (:) will appear to confirm the input.
- 

7.3.3. Adjustment of Velocity Integrator Frequency (VI)

- The adjustment of velocity integrator frequency (VI) shall be conducted after the velocity gain (VG) is adjusted.

(1) Start “VI” adjusting program.

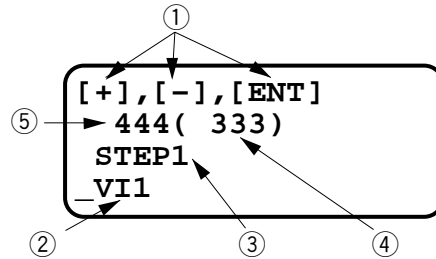

- The messages are shown on the left.
- Inputting the plus (+) or minus (-) key changes “VI” value (The “VI” value varies with an actual load inertia and revolution speed.)

- Explanation of the messages

① Key function

SHIFT and **- +** : Pressing key one time increases 1 resolution of “VI”.

- + : Pressing key one time decreases 1 resolution of “VI”.

ENT : Store “VI” value in the memory and completes the adjustment.

② Indicates present “VI” value.

③ Indicates “VI” value changed by pressing plus (+) or minus (-) key.

④ Response index number: The lower number denotes better response.















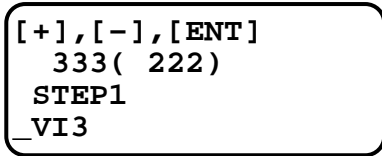



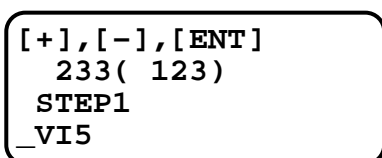

⑤ Positioning index number: The lower number denotes quicker positioning.

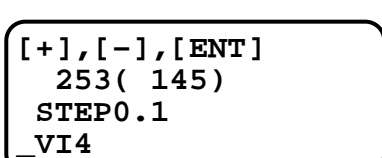
Note: Changing “VI” step (③).

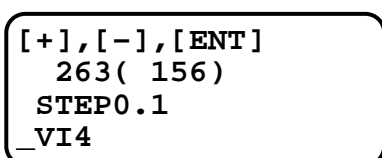
If you want to change the resolution of step, press space key or back space key.

Space key : Changes the step to 1/10 of present resolution.
(Pressing twice makes 1/100.)

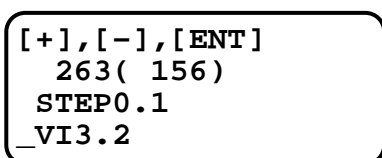
Back space key : Changes the step to 10 times of present resolution.
(Pressing twice makes 100 times.)

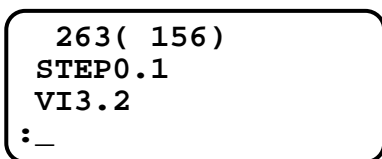
- (2) Observing the Motor operation, press the plus (+) key several times.
- Pressing ,   ...
- As the resonance index decreases, the movement of the Motor is getting crisply.
-  
- ```
[+],[-],[ENT]
333(222)
STEP1
_VI3
```
- (3) Keep pressing the plus (+) key, till the Motor starts hunting and stops.
- Pressing ,   ...
-  
- ```
[+],[-],[ENT]
233( 123)
STEP1
_VI5
```
- (4) Keep pressing the minus (-) key until the Motor stops hunting and starts moving.
-   ...
-  
- ```
[+],[-],[ENT]
253(145)
STEP0.1
_VI4
```
- (5) Set the “VI” value to 80% of displayed “VI” when a hunting us stopped.  
 $4 \times 0.8 = 3.2$
- Input the space key to change the resolution of “VI” setting value from 1.0 to 0.1.
- (6) 
-  
- ```
[+],[-],[ENT]
263( 156)
STEP0.1
_VI4
```
- Press the minus key till “VI” value reaches to 3.2.
- (7)   ...
-  
- ```
[+],[-],[ENT]
263(156)
STEP0.1
_VI3.2
```
- Input the enter key to store the “VI” value.
- (8) 
- A colon ( : ) will appear to confirm the input.
-  
- ```
263( 156)
STEP0.1
VI3.2
:_
```

7.4. Setting Filters (Tuning Level 2)

- When positioning, the Motor may resonate mechanically and generate a noise of certain frequency. Using Megatorque Motor's software "low-pass filters" (Parameter FP and FS), the noise level can be reduced.

The unit of parameters of FP and FS is cycles / second (HZ).

- If low frequency less than 100Hz is set to parameters "FP" and "FS", hunting or unstable positioning may occur.
- Before using filters, make sure that all adjustments of gain (VG) and integrator frequency (VI) are completed.
- Use same demonstration program (SA/AJ) for adjusting filters. Follow the procedures (1)~(7) in "7.2.4. Trial Running (Tuning Level 1)".

- (1) Start "FP" adjusting program.



The message is displayed as shown below. Press plus (+) or minus (key) to change "FP" value. (The display shown below is an example. Those values shall be set to the conditions for actual use.)

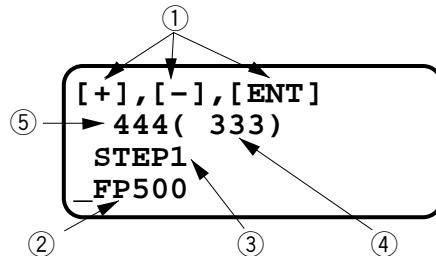

- Explanation of the messages

- ① Key function

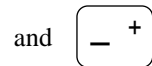

: Pressing key one time increases 10 resolution of "FP".



: Pressing key one time decreases 10 resolution of "FP".



: Store "FP" value in the memory and completes the adjustment..

② Indicates present "FP" value.

③ Indicates "FP" value changed by pressing plus (+) or minus (-) key.

④ Response index number: The lower number denotes better response.

⑤ Positioning index number: The lower number denotes quicker positioning.

Note: Changing "FP" step (③).

If you want to change the resolution of step, press space key or back space key.

Space key : Changes the step to 1/10 of present resolution.
(Pressing twice makes 1/100.)

Back space key : Changes the step to 10 times of present resolution.
(Pressing twice makes 100 times.)

- (2) Decrease low-pass filter frequency (FP) to lower noise level by typing minus (-) key several times.

...



```
[+],[-],[ENT]
333( 222)
STEP10
FP500
```

- (3) If the Motor starts to work unstably, increase "FP" value by typing plus (+) key several times.

Pressing , ...



```
[+],[-],[ENT]
233( 123)
STEP1
FP120
```

- (4) Type the enter key to complete the adjustment.



```
233( 123)
STEP1
FP120
:_
```

Note : To deactivate the filter, input the filter command with "0" data.

For example type as:



```
:FP0
:_
```

Note : Setting "Notch Filter"

- When setting notch filter, you can connect the ocsilloscope to monitor pins on Driver Unit front panel to know the resonance frequency.

• Example

- ① Check the resonance frequency as shown in Figure 7-3.
- ② If the resonance frequency is 200Hz, input

to set notch filter frequency.

Figure 7-3

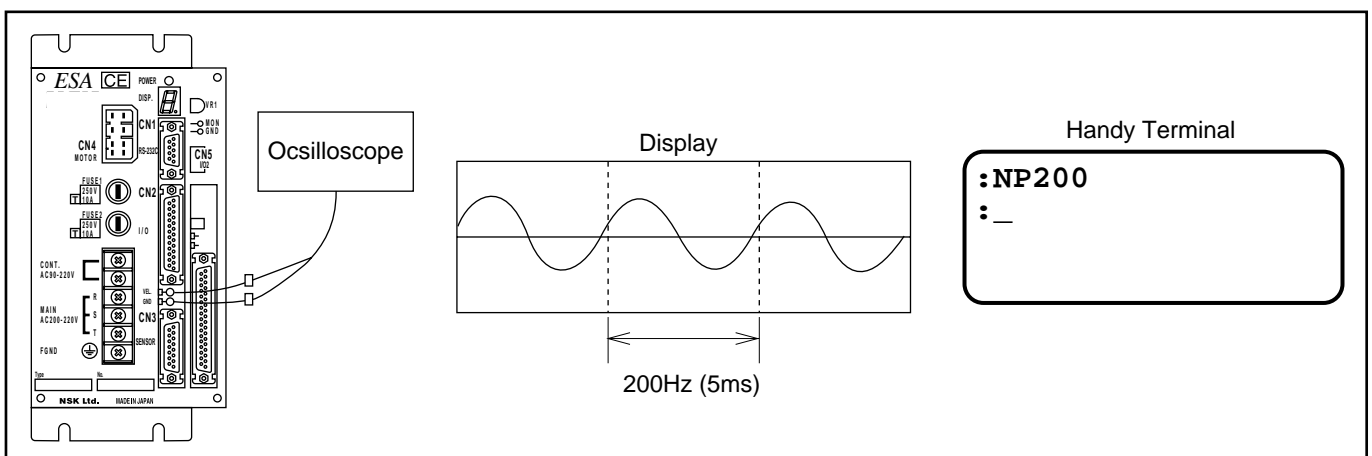

(Blank Page)

8. Operational Function

8.1. General Operation and Function

8.1.1. Servo “ON”

- After the Driver Unit power is turned on and its DRDY output circuit becomes closed, making SVON input ON should make motor servo-on.
- The position error counter will be cleared when SVON input is OFF.
- When SVON input is ON, the “MO” command results in servo-off.
- The “SV” or “MS” command will cancel this “MO” command effect.

Figure 8-1

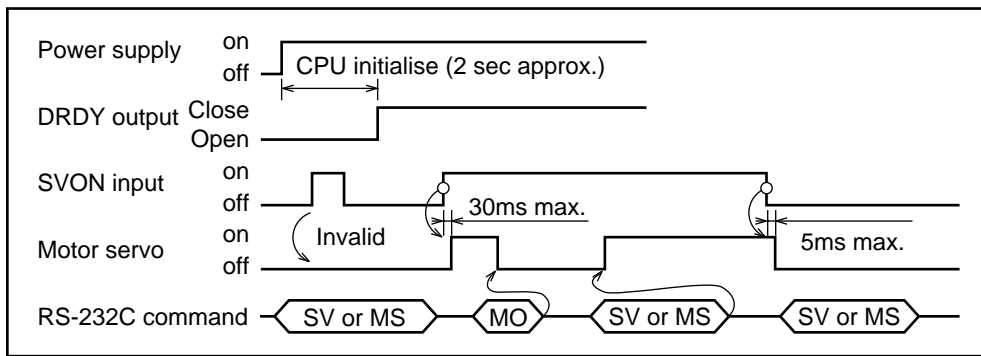

- Take the following precaution when turning ON/OFF the main power supply and the control power supply separately:
 - When turning on the main power supply with the control power supply turned on: Turn on the main power supply first, then the SVON input.
 - When turning off the main power supply with the control power supply turned on: Turn off the SVON input first, then the main power supply.
- * When the main power supply is turned off in the servo-on state, the Driver Unit outputs the AC Line under-voltage alarm. (Once this alarm occurs, it will not recover unless the power is turned on again.)

Figure 8-2

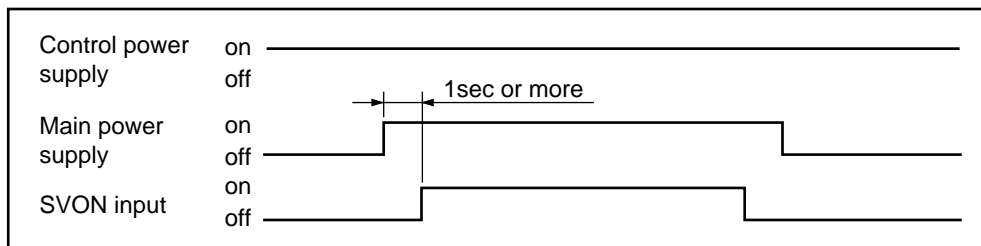

8.1.2. Emergency Stop

- Turning on the EMST input stops the position loop control function and stops the Motor in the servo-lock state* under velocity loop control.
- No motion commands will be accepted while EMST input is on.
- In the EMST state, the LED on the front panel indicates “F4”. The DRDY output remains unchanged (closed).
- The polarity of the EMST signal input port is set to A contact before shipment, but it can be changed to B contact (refer to the AB parameter).
 - * Position loop control is not performed this time. If the possibility exists of an external force being applied to the Motor in this state, use a mechanical brake. When the SVON input is OFF after EMST input is ON, the Motor remains servo-on for one second after the EMST input went on. If the EMST input is ON when the SVON input off, motor will be servo-off.

Figure 8-3

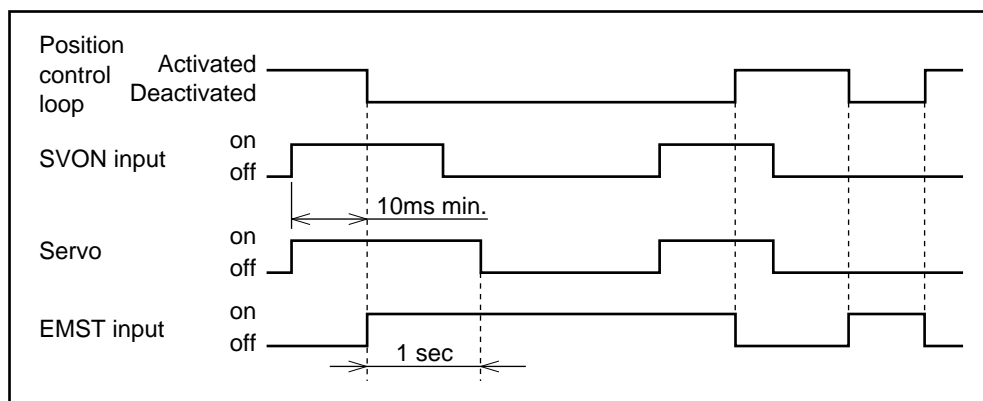

- The Driver Unit may not accept EMST input unless it stays on for 10 ms or longer.

8.1.3. Clearing Position Error Counter

- If the CLR input is on, position loop error will be cleared.
- When the excess position error alarm occurs, turning on the CLR input clears the position error counter and recovers from the alarm state.
- * The Driver Unit detects the rising edge of the CLR input pulse and clears the position error counter to zero. Then, the counter continues its operation regardless of the state of the CLR input (even when it remains on).

Figure 8-4

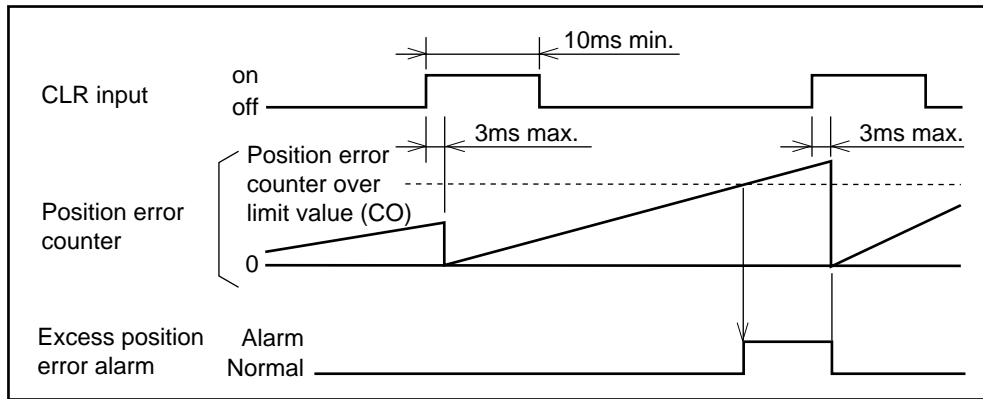

- Software thermal and program error alarms can be cleared by inputting “CLR” on. (Other alarms cannot be cleared using “CLR”.)

8.1.4. Integration off (IOFF)

- Parameter VI (Velocity Integrator Frequency) will be invalidated when IOFF input is activated. Simultaneously, VG (Velocity Gain) will be lowered according to LG (Gain lowering coefficient) setting. ($VG \times LG$)
- VI is validated when IOFF input is turned off.

Figure 8-5

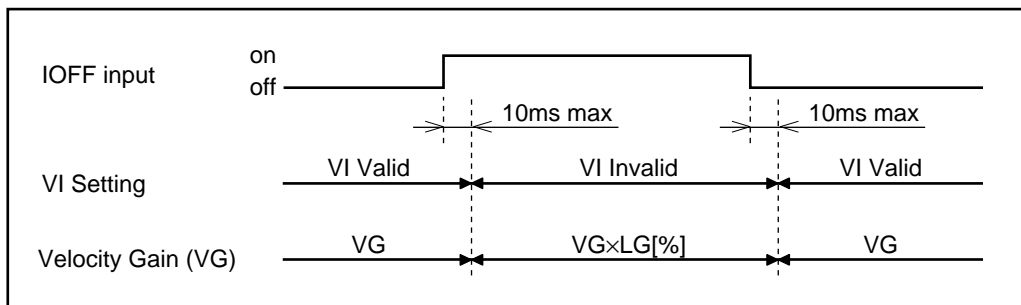

8.1.5. Overtravel Limit Switch

8.1.5.1. Hardware Overtravel Limit Switch

- Use the OTP and OTM inputs to restrict the range of Motor rotation.
- If the OTP input is activated, the Motor motion will stop immediately and remain in servo-on. The Motor can be rotated counter clockwise only.
- If the OTM input is activated, the Motor motion will stop immediately and remain in servo-on. The Motor can be rotated clockwise only.
- * The polarity of the OTP and OTM input ports is set to A contact before shipment. It can be changed to B contact (refer to the section on the AB parameter).
- * Besides the OTP and OTM inputs, the Motor rotation can also be limited by software (software overtravel limit function) in the Driver Unit. Refer to “8.1.5.2. Software Overtravel Limit Switch”.
 - When the overtravel error occurs, the DRDY output will be open and LED on the front panel indicates the following alarms.
 - OTP or OTM limit : F3
 - Software overtravel limit : F2

Figure 8-6

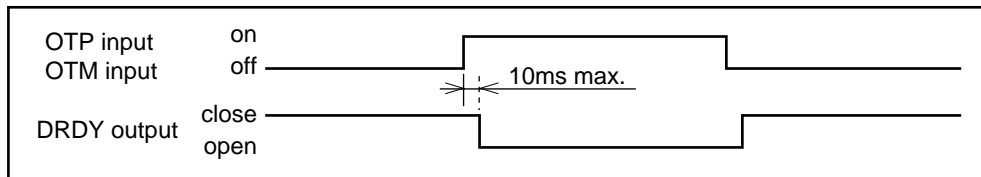

- * When the OTP or OTM input works in the middle of Home Return operation, the Motor completes the Home Return operation after performing the following:

(1) When the Motor is turning CCW

Caution : ● The OTP input is invalid (the Motor continues rotation).

- Turning on the OTM input makes the Motor decelerate, then rotate in reverse.

(2) When the Motor is turning CW

Caution : ● Turning on the OTP input makes the Motor decelerate, then rotate in reverse.

- The OTM input is invalid (the Motor continues rotation).

8.1.5.2. Software Overtravel Limit Switch

Notes to be taken in overtravel limit setting

- Caution** : ① *The overtravel area should be 1000 [pulses] or wider. When the overtravel area is too narrow the Motor may turn through the prohibited area.*
- ② *Set the overtravel limits with ample margin, giving consideration to the overshoot of the mechanism controlled by the Motor.*
- ③ *When the command to take the shortest route to destination is executed, the Motor takes the shortest rout regardless of the software overtravel limit setting.*

- This function becomes valid after the Home position is determined by Home Return or AZ command.
- Use the OTP and OTM commands to set the overtravel limit values.

<Operation> Setting by teaching

- (1) Turn off the Motor servo.

M O ENT



:MO
:_

- (2) Move the Motor's rotor manually to a point to be the overtravel limit on the plus side.

- (3) Input the password.

/ N S K SP
O N ENT



:MO
:/NSK ON
NSK ON
:_

- (4) Register the present position as the overtravel limit on the plus side. The registered overtravel limit value appears on the display.

O T P / S T
ENT



:OTP/ST
OTP123456
OTM0
:_

- (5) Move the Motor's rotor manually to a point to be the overtravel limit on the minus side.

- (6) Input the password.

/ N S K SP
O N ENT



:MO
:/NSK ON
NSK ON
:_

- (7) Register the present position as the overtravel limit on the minus side. The registered overtravel limit value appears on the display.

O T M / S T
ENT



:OTM/ST
OTP123456
OTM456789
:_

- (8) Move the Motor's rotor into the overtravel area. Check that the Driver Unit outputs the F2 alarm (check the alarm indicated on the LED or input the TA command).

- After the Home Return is completed, take the following steps:
- If the F2 alarm is not output this time, check the following:
 - Is the position scale home position located between OTP and OTM?
 - In the single rotation position scale: is $OTP < OTM$?
 - In the Linear position scale: Is OTP a positive value, and OTM a negative value?

Setting by position scale data

- When the overtravel limit values are already known, users can directly set these values in the OTP and OTM command parameters.

8.1.6. Alarm Output

- After the power is on and “CPU” is initialized, “DRDY” output is closed when alarms are not detected.
- The “DRDY” output opens when the alarm is detected.
- Alarm signal shall be connected to “alarm input” of user’s controller.

Figure 8-7

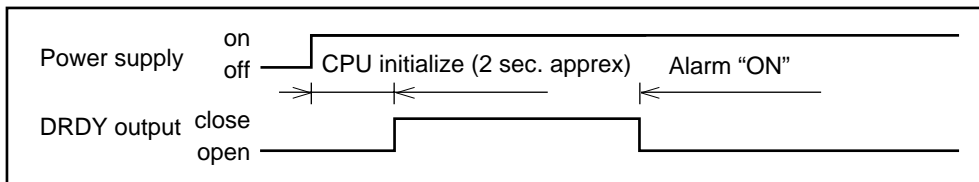

8.1.7. Brake Signal Output

- The BRK output circuit opens in the following states:
 - ① SVON input : off
 - ② Occurrence of an alarm which causes the Motor servo to turn off (example: memory error, etc.).
 - ③ During system initialization after the power is turned on
 - ④ EMST input : on

Figure 8-8

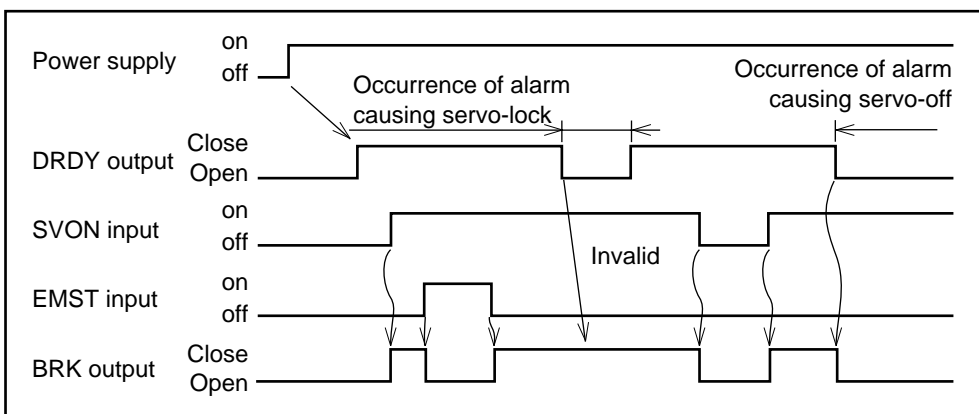

- * This signal can be used to control negative (normally on) brake, which activates the external brake when the Motor servo goes off or the EMST is input.

8.1.8. In-Position Output

- In-Position output condition is determined by the following parameters.

Table 8-1

Parameter	Function (Name)	Shipping set
FW	IPOS outputting time range (Output mode)	FW1
IN	In-Position limit value	IN100
IS	In-Position stability timer	ISO

Figure 8-9

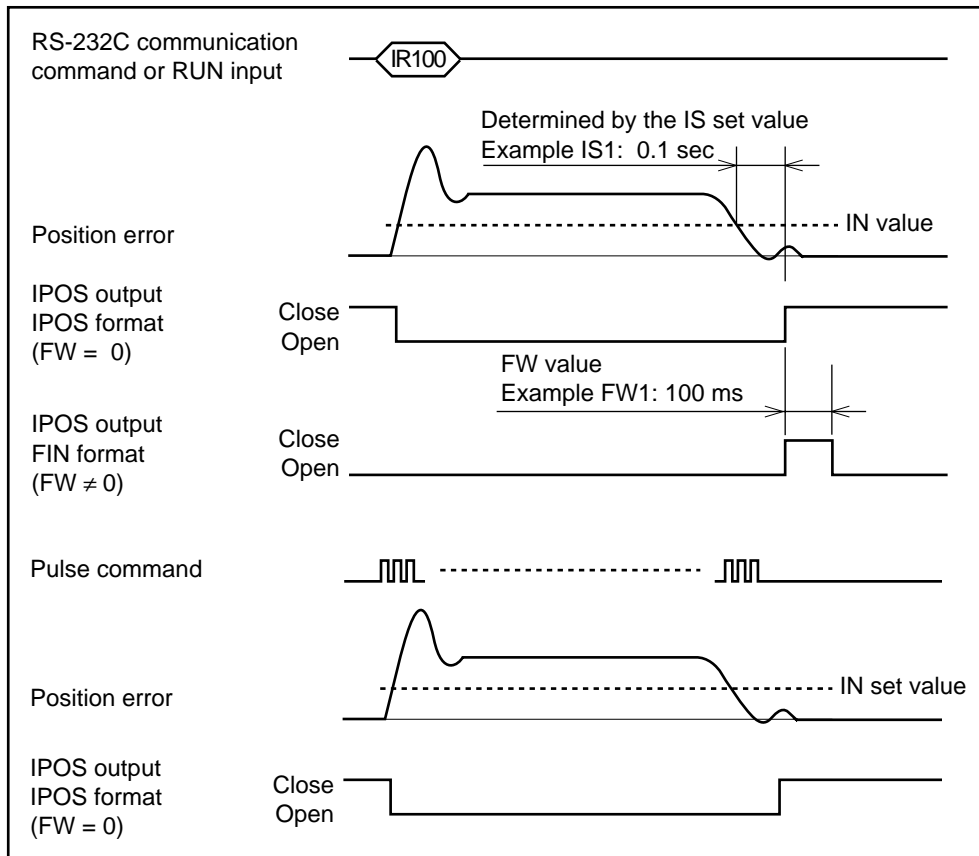

8.1.8.1. Output Signal Format

- The output signal format --- either IPOS format or FIN format --- can be selected by setting the FW parameter.
 - FW data : FIN format is selected when data ≠ 0 (shipping set: FW1)
 - FW0 : IPOS format

(1) When data of parameter “FW” is not “0” (Zero) (FIN format)

- “IPOS” output indicates that the positioning has completed.
- IPOS will be output for every positioning start command such as **RUN** and **HOS**.
- Out put format
 - IPOS output is always open and it closes only for the moment set by “FW” when completion of positioning. (Closing time unit in “FW” is 100m sec. Shipping set FW1: 100m sec.)

Recommendation

We recommend to use FIN format when you use the programmable indexer in the Driver Unit.

- “IPOS” will not be output for pulse train operation and jog operation.
- When the positioning is stopped in the middle of operation by the emergency stop or overtravel limit switch, “IPOS” will not be output.

(2) When “data” of parameter “FW” is 0 (Zero) (IPOS format)

- The format is to indicate if there is an error between position command and present position.
- Basically “IPOS” output will be closed only when residual pulses in the position error counter is within the range set by “IN” parameter. In other state, it is open.
- However, even residual pulses in the position error counter is within the “IN” value, output is forced to open during pulses are generated internally when executing programmable indexer, Home Return, jog and operations via RS-232C.

Recommendation

Select “IPOS” format for pulse train operation or RS-232C operation.

- When the positioning is stopped in the middle of the operation by emergency stop or overtravel limit signal, IPOS output will stay closed if residual pulses of position error counter are within the “IN” value.
- When executing pulse train input operation, even pulses are being input, IPOS output is closed if residual pulses in the position error counter are within “IN” value.
[This state tends to occur when executing low speed operation or feed forward compensation is applied (“FF” parameter).]

8.1.8.2. Parameter “IN”

- Parameter “IN” is to decide positioning accuracy.
- “IPOS” output will be closed when residual pulses of position error counter are within the range of “IN” parameter.
- The unit of parameter “IN” value is the maximum resolution (pulses) of the motion detector (resolver).

Table 8-2

Motor series	Resolution (pulses/revolution)
YS, JS1, JS2, RS	614400
SS	491520
AS, BS, JS0	409600

● Example (YS series)

Desired positioning accuracy (repeatability): ± 100 sec.

$$\begin{aligned} \text{“IN” set value} &= \frac{\text{resolver resolution}}{360} \times \text{repeatability (degree)} \\ &= \frac{614400}{360} \times \frac{100}{3600} \\ &= 47 \text{ pulses} \end{aligned}$$

8.1.8.3. Parameter “IS”

- “IS” is to confirm the stability of the positioning. When the in-position output signal is IPOS format, if the parameter “IN” value is smaller (roughly less than FN10), “IPOS” output will be instable in the moment of positioning settling, even all servo gains are adjusted properly.
- “IS” parameter should be set to eliminate above instability.
- When “IPOS” output is in “FIN” format, “IS” parameter prevents to output IPOS signal before the Motor complete the positioning.
- “IS” parameter is not effective for pulse train input operation and jog operation.

8.1.8.4. "IPOS" Output in Special Occasion.

(1) When 0 (Zero) movement operation is executed.

● Example

When [AD0] or [AR0] is executed even the Motor is in the Home position, movement of the Motor is 0 (Zero). Followings show "IPOS" output states.

① "IPOS" format IS = 0

- There is no internal pulse output and "IPOS" output remains close if residual pulse of position error counter are within "IN" value.

② "IPOS" format IS ≠ 0

- Even no pulse is internally generated, "IPOS" output will be opened for the moment set by "IS" value to check positioning stability.

③ "FIN" format

- Even no pulse is generated internally, "IPOS" output signal shall always be returned for positioning start command.

(2) Sequential operation (BCD mode) for Programmable Indexer.

① "IPOS" format

- After the positioning is completed, execute next channel program, while "IPOS" output remains open.

② "FIN" format

- After the positioning is completed, "IPOS" output closes for the moment which is set by the parameter "FW", then execute the next channel's program after "IPOS" output is opened again.

8.1.9. Position Feedback Signal

- Resolution

Set the $\phi A/\phi B$ resolution using the FR parameter (via RS-232C).

Table 8-3

		Unit: pulses/rotation		
Motor series	Feedback signal	$\phi A, \phi B$		ϕZ
		FR1	FR0	
YS, JS1, JS2, RS		153600	38400	150
SS		122880	30720	120
AS, BS, JS0		153600	38400	150

* When the resolver resolution is set to the automatic resolution switching or 10-bit setting, set the FR parameter to FR0. When it is set to FR1, $\phi A/\phi B$ will not be output.

- Output timing

Figure 8-10

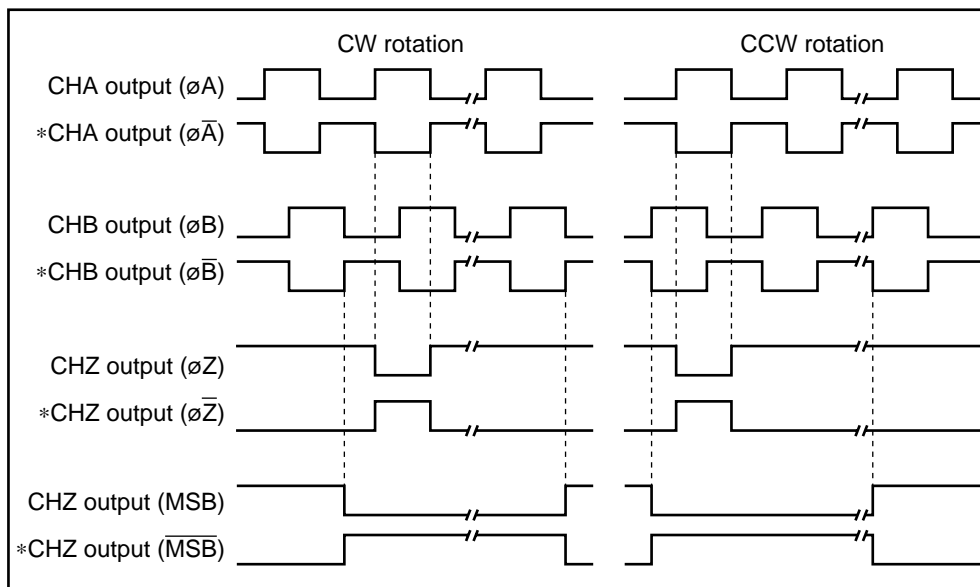

* The phase can be reversed by the FD parameter (set via RS-232C).

FD0: Standard ; at CW rotation, ϕA becomes ON before ϕB

FD1: Reverse ; at CW rotation, ϕB becomes ON before ϕA

* The output specification of the CHZ signal--whether to output ϕZ or MSB--is selected by the FZ parameter (set via RS-232C).

FZ0: ϕZ

FZ1: MSB

8.1.10. Monitor Functions

- The Motor operation can be monitored by using the analog velocity monitor pins, which are provided in the front panel of Driver Unit, and RS-232C communication.

Table 8-4

Item	RS-232C communication command	Monitor output	Description
Velocity	—	VELOCITY check pin on the front panel	<ul style="list-style-type: none"> • Monitors the Motor velocity in forms of analog voltage output.
Position error	TE	CN1 via RS-232C terminal	<ul style="list-style-type: none"> • Monitors value of the position error counter. • For the details, refer to “11. Commands and Parameters.”
Input/output	IO		<ul style="list-style-type: none"> • Monitors the input/output status (on/off) of CN2. • For the details, refer to “11. Commands and Parameters.”
Current position	TP		<ul style="list-style-type: none"> • Monitors the current position in the absolute position scale. • For the details, refer to “11. Commands and Parameters.”
Parameter value	TS		<ul style="list-style-type: none"> • Monitors the set values of parameters. • For the details, refer to “11. Commands and Parameters.”
Alarm	TA		<ul style="list-style-type: none"> • Monitors the alarm status. • For the details, refer to “13.1.2. TA Command.”
Channel program	TC		<ul style="list-style-type: none"> • Monitors the program stored in the channels. • For the details, refer to “11. Commands and Parameters.”

8.1.10.1. Velocity Monitor

- The user can monitor the velocity of the Motor by measuring the voltage between VELOCITY and GND check pins on the front panel.

● **When the resolver is set to 12-bit resolution**

Note: ± 10 V is only a typical value; actual values vary slightly. The voltage is not a precise representation of the velocity.

Figure 8-11

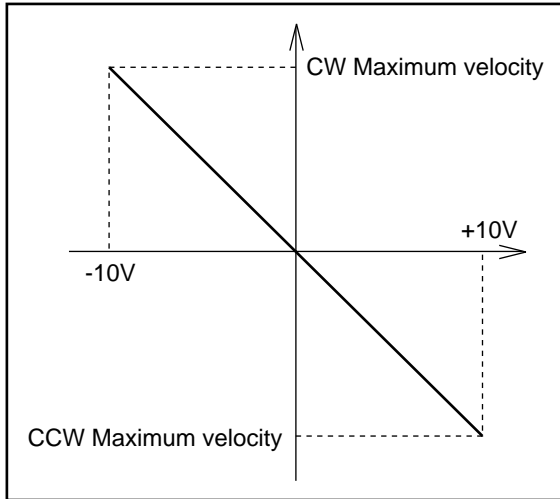

● **When the resolver is set to 10-bit resolution or automatic resolution switching**

Note: ± 7.5 V is only a typical value; actual values vary slightly. The voltage is not a precise representation of the velocity.

Figure 8-12

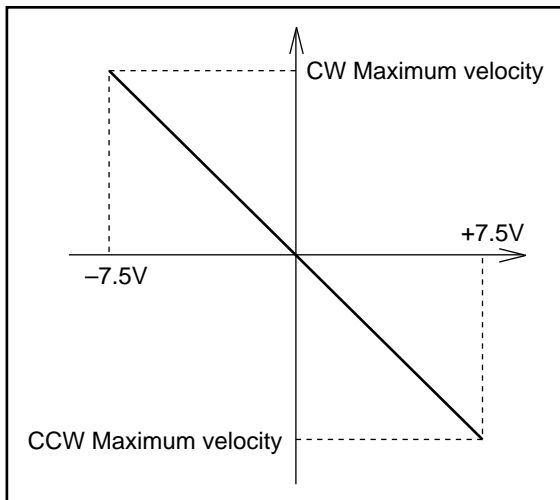

Table 8-5: Maximum velocity

Motor series	Resolver resolution 12-bit setting	Automatic resolution switching or 10-bit setting
YS, JS1, JS2, RS	1 r.p.s.	3 r.p.s.
SS	1.25 r.p.s.	3.75 r.p.s.
AS, BS, JS0	1 r.p.s.	3 r.p.s.

- Automatic resolution switching, 12-bit setting and 10-bit setting are selected by the RR parameter.

8.1.10.2. Monitoring I/O State (IO)

- The Input/Output signal state of CN2 and CN5 connectors can be monitored using “IO” command.
- This is useful to check the wiring.
 - Input format
 - IO0/RP : Monitor CN2 I/O state
 - IO2/RP : Monitor the I/O related to programmable indexer
 - IO3/RP : Monitor the I/O related to Jog operation

Note: /IP is to set the frequency of the monitoring.

- Without /IP : One-shot monitoring
- With /IP : Real-time monitoring (Repeats monitoring)

- Display format
 - Bit map representing Input/Output in 1 line (See Figure 8-13 to 8-15.)

- The status is displayed on the Handy Terminal screen.

Figure 8-13: IO0/RP (Monitor CN2 I/O state)

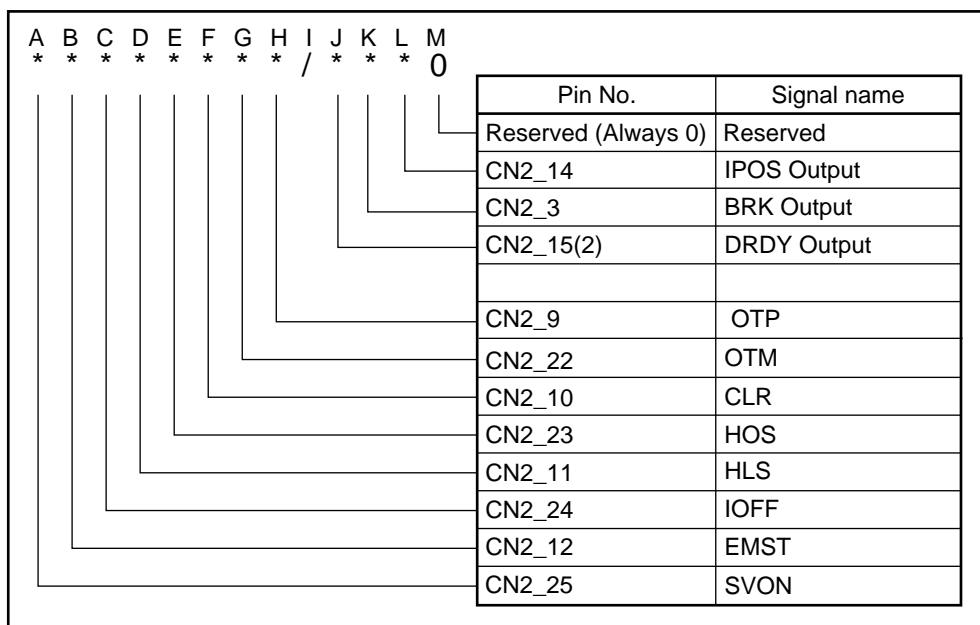

Figure 8-14: IO2/RP (Monitor I/O related to programmable indexer)

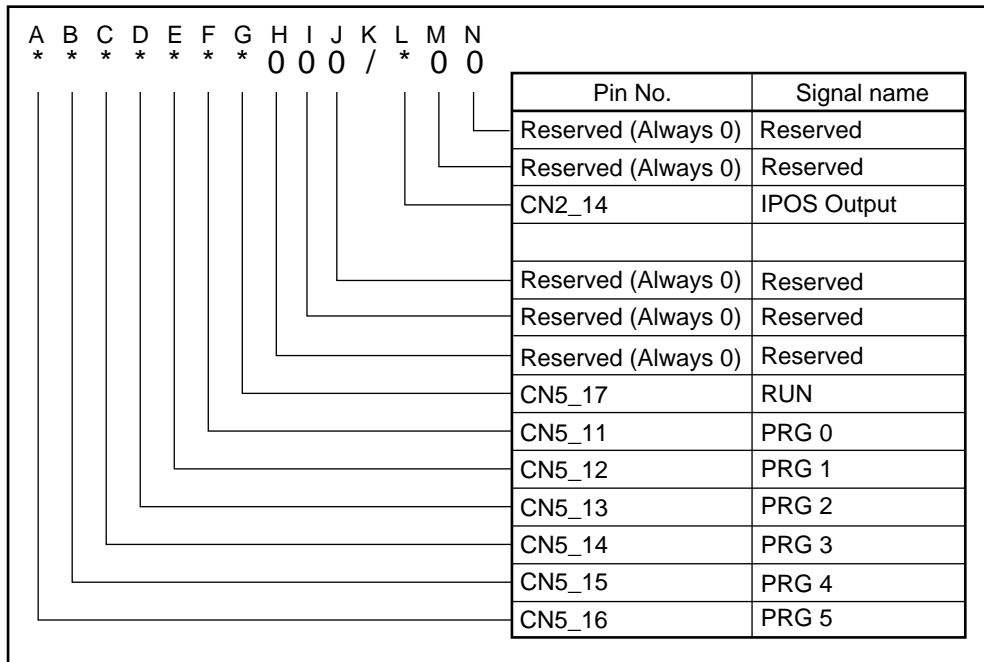

Figure 8-15: IO3/RP (Monitor the I/O related to Jogging operation)

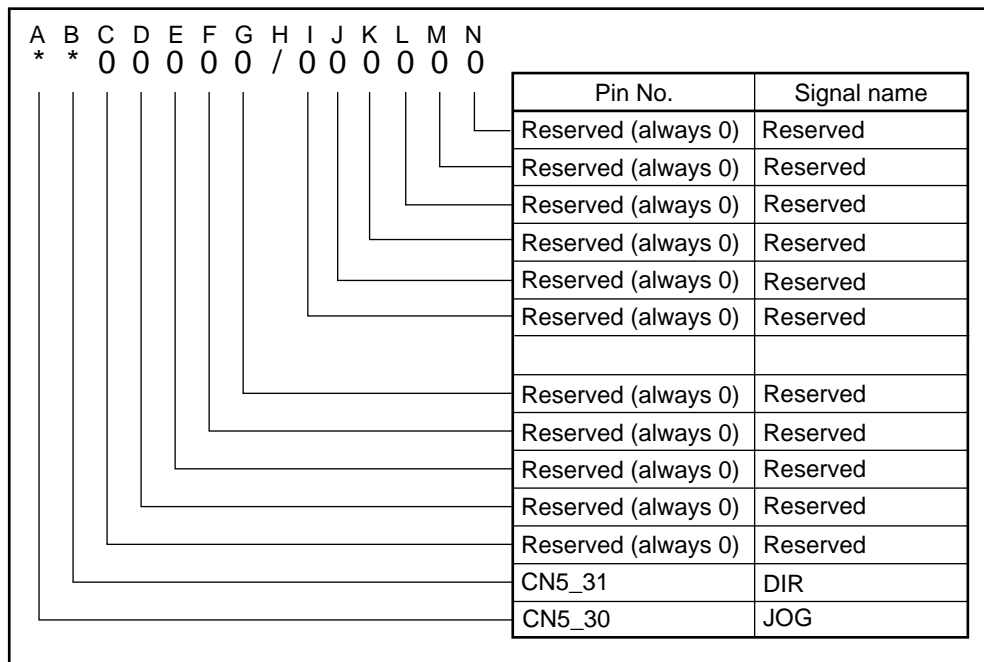
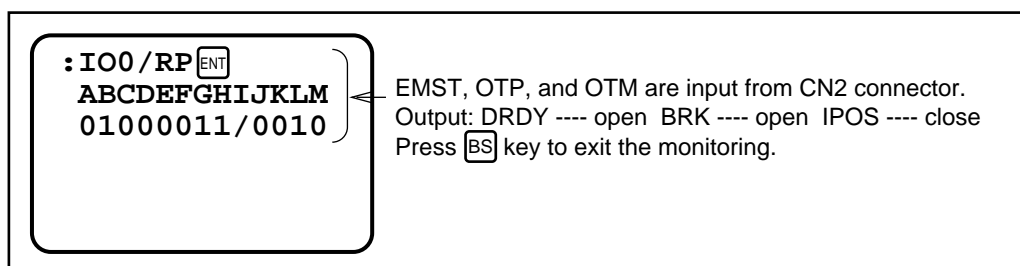

Table 8-6: Meaning of display data

	Display: 1	Display: 0
Input port	ON	OFF
Output port	Close	Open

Figure 8-16: Example of monitoring



[Example] Verify the Programmable Indexer start command “RUN” is ON.

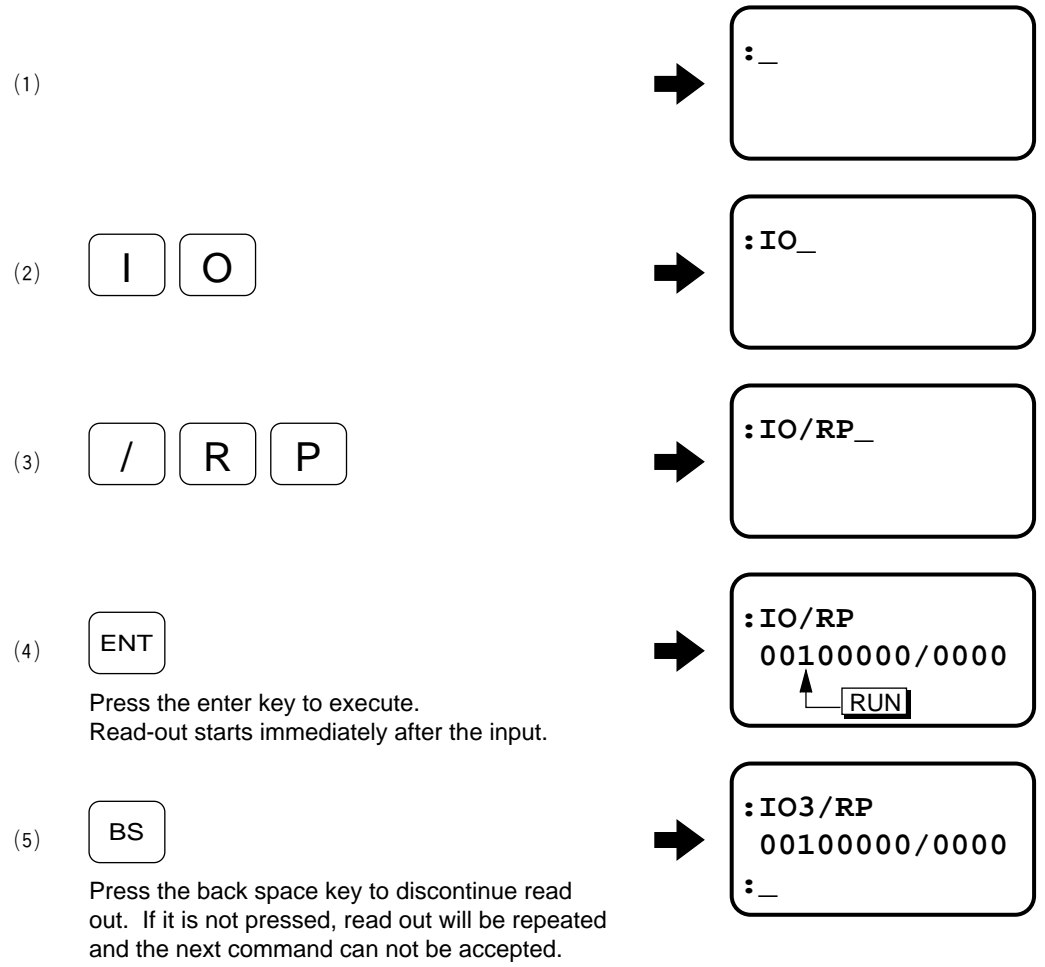

- Above example shows that read out of RUN input is “1”, which indicates “RUN” input is ON.

[Reference]

- Read-out follows the changes of signal status while repeating reading-out.
(Signals ON and OFF are followed by 1 and 0 in the display.)
- If the option code “/RP” is not entered, the read-out at the moment will be displayed for only once.

8.1.10.3. Reading Current Position

(1) Reading the position scale current value in the units of pulse

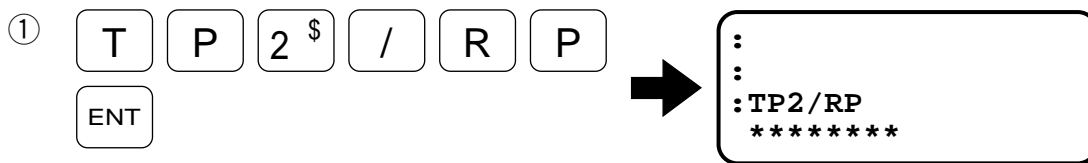

The position scale value is displayed continuously in the units of pulse. Moving the Motor's rotor changes the value on the display.



Press the BS key to end the display.

(2) Reading the position scale current value in the units of 1/100 degree

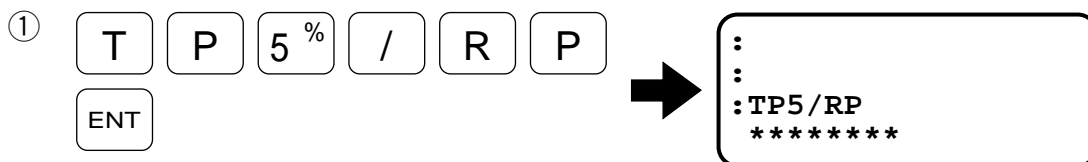

The position scale value is displayed continuously in the units of 1/100 degree. Moving the Motor's rotor changes the value on the display.



Press the BS key to end the display.

8.1.10.4. Analog Monitor

- The voltage between analog output pin (MON) and analog ground pin (GND) on the front panel of the Driver Unit monitors one of the following Motor and Driver Unit conditions.
 - Velocity ----- actual velocity of the Motor
 - Velocity command ----- velocity command given to the Motor from the Driver Unit
 - Velocity error ----- error between velocity command and actual velocity, per one sampling instant
 - Torque command ----- torque command given to the Motor from the Driver Unit
 - Phase C current command --- current command given to the Motor phase C from the Driver Unit
 - Position command ----- position command given to the Motor from the Driver Unit
 - Position error counter ----- error between position command and actual position
- MN command select one of the conditions to be monitored as shown in Table 8-7.

Table 8-7

Monitoring condition	MN command
Velocity	MN 0
Velocity command	MN 1
Velocity error	MN 2
Torque command	MN 3
Phase C current command	MN 4
Position command	MN 5
Position error	MN 6
Position error	MN 7

- The monitor output scale is shown below.

Figure 8-17: Velocity (MN0)

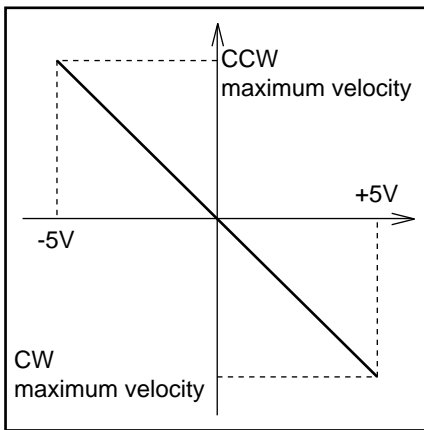

Figure 8-19: Velocity error (MN2)

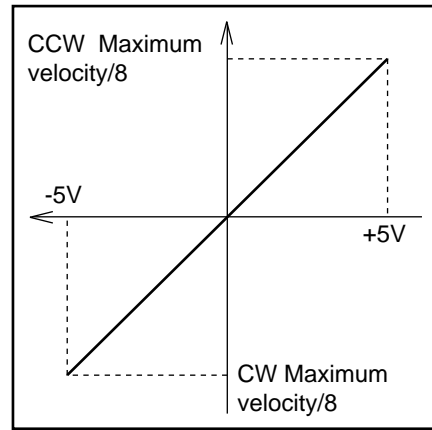

Figure 8-18: Velocity command (MN1)

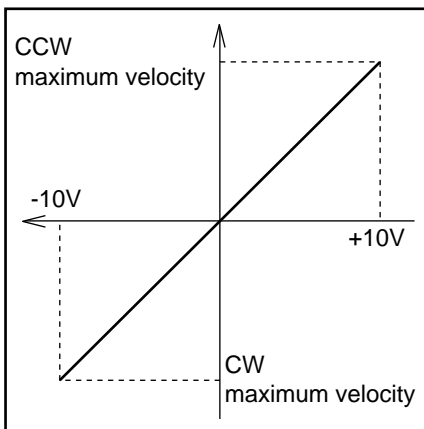

Figure 8-20: Torque command (MN3)

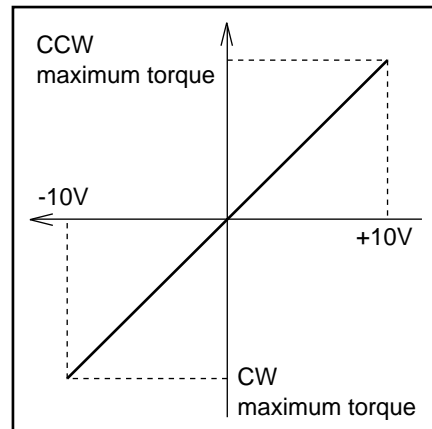

Figure 8-21: Phase C current command (MN4)

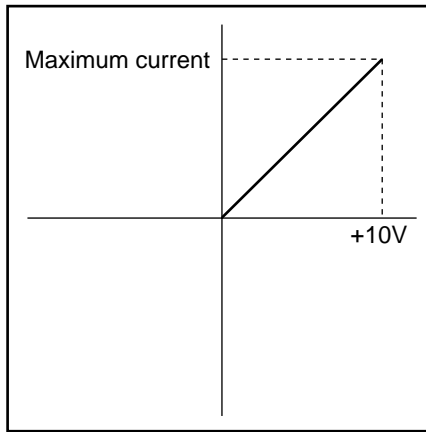

Figure 8-23: Position error (MN6)

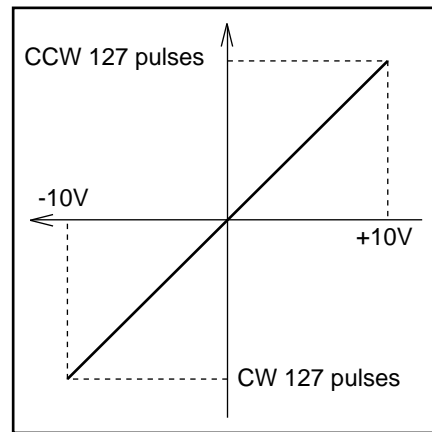

Figure 8-22: Position command (MN5)

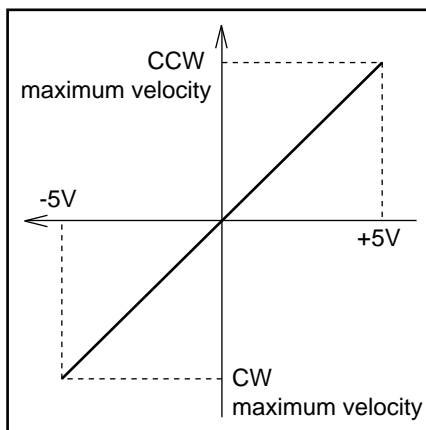
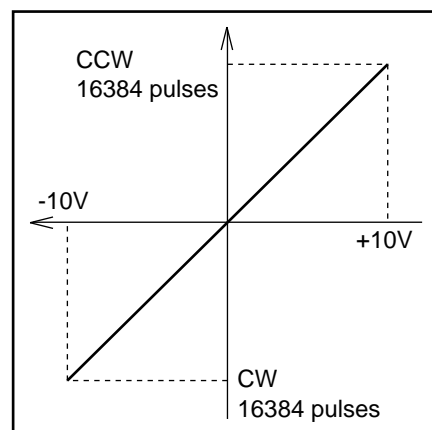

Figure 8-24: Position error (MN7)



Caution : The maximum velocity shown in above figures is for the cases when the selection of resolver resolution is automatic or 10 bit setting.

8.2. For More Advanced Operation

8.2.1. Position Scale

- The ESA25 Driver Unit has a position scale for positioning and overtravel limit.

8.2.1.1. Resolution

- The Motor resolver has teeth for detecting its position, and each tooth is digitally divided into 4096. In other words, the resolution of Motor position detection is $4096 \times$ number of teeth per turn.
- Table 8-8 lists Motor series and the resolution.

Table 8-8

Motor series	Number of teeth	Resolution [pulses / rotation]
YS, JS1, JS2, RS	150	614400
SS type	120	491520
AS, BS, JS0	150	614400

8.2.1.2. Direction of Position Scale

Caution : For your safety, the direction of the hardware overtravel limit switches are fixed to the Motor as follow regardless of the DI setting:

- OTP: CW direction
- OTM: CCW direction

- The direction of position scale counting can be switched by the DI command.

Table 8-9

DI setting	CW direction	CCW direction
DI0*	Plus direction	Minus direction
DI1	Minus direction	Plus direction

* : Shipping set

- When the position scale direction is set, the directions of operations performed by the following functions are also determined.
 - Pulse train operation
 - Positioning via communication (IR, ID, AR, AD, HS)
 - Programmable indexer
 - Home Return
 - Jog
 - Software overtravel limit switch

8.2.1.3. Types of Position Scale

- Three types of position scale are available for the user to select the appropriate type for each purpose. Position scale type can be switched by setting the PS command.

Table 8-10

PS setting	Type of position scale	Application
PS0	Linear position scale	Ball screw driving, limited motion range.
PS1*	Single-rotation position scale	General indexer, etc.
PS2-99	Multi-rotation position scale	Chain driving, etc.

* : Shipping set

1) Linear Position Scale

- This position scale extends linearly from the Home position in both plus and minus directions.
- Scale values range from -2,147,483,648 [pulses] to +2,147,483,647 [pulses] with the Home position at 0. The coordinate value increases in the plus direction. When it exceeds +2,147,483,647 [pulses], the value returns to -2,147,483,648 [pulses]. Falling below -2,147,483,648 [pulses], the value returns to +2,147,483,647 [pulses].

Figure 8-25: Linear position scale

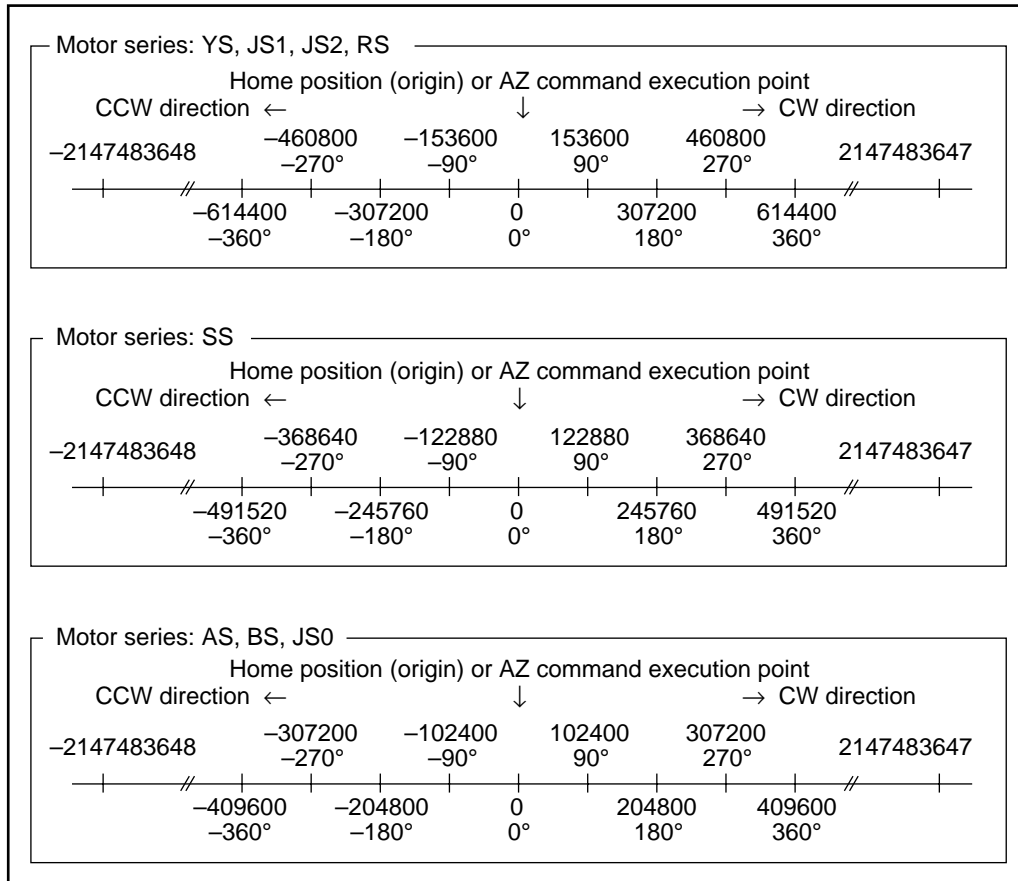

2) Single Rotation Position Scale

- Scale starts from the Home position (origin) and extends only in the plus direction. The coordinate value returns to 0 after a 360° turn.
 - Motor Series: YS, JS1, JS2 and RS
Coordinate values from 0~614399 [pulses]
 - Motor Series: SS
Coordinate values from 0~491519 [pulses]
 - Motor Series: AS, BS and JS0
Coordinate values from 0~409599 [pulses]

Figure 8-26: Single-rotation position scale

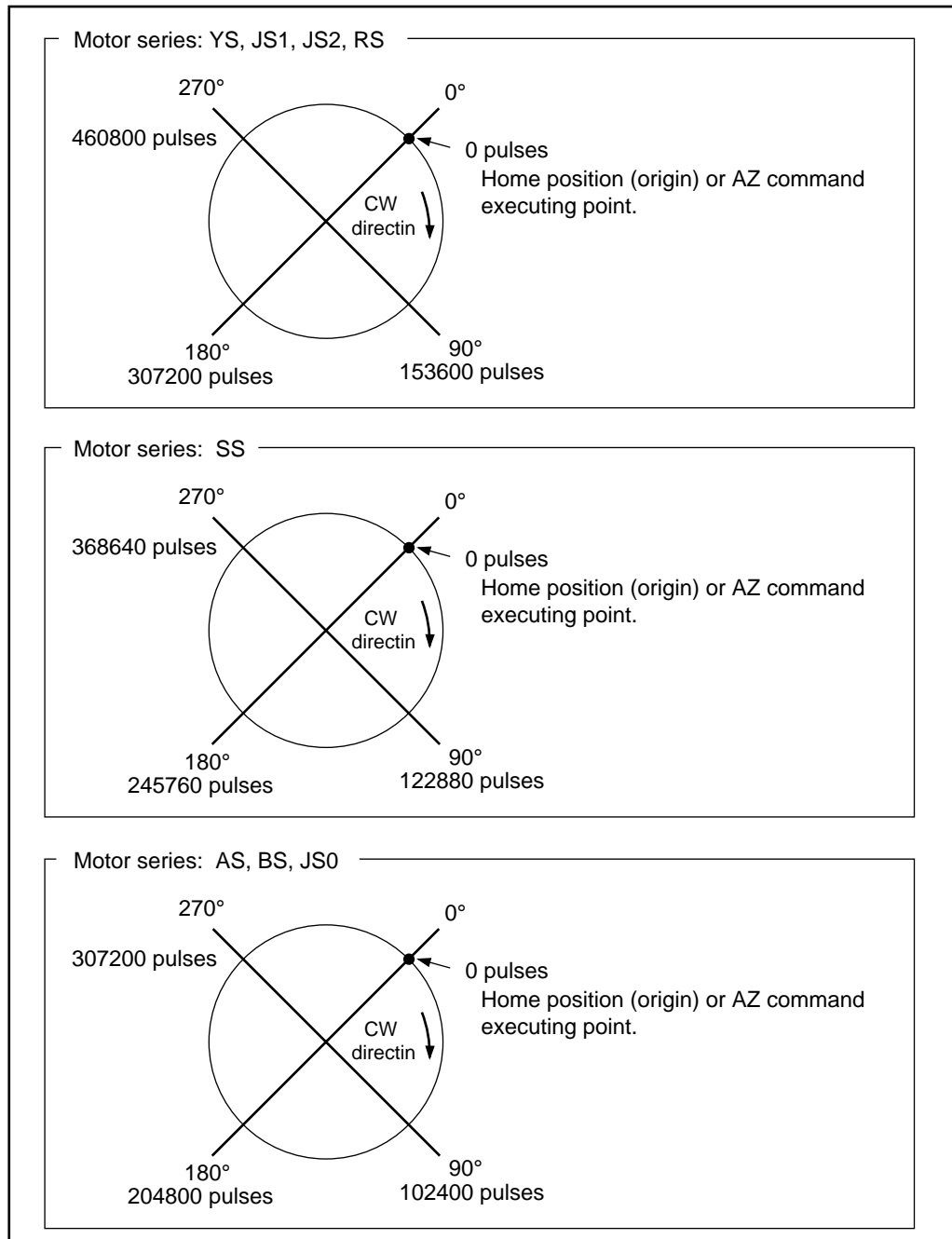

3) Multi-Rotation Position Scale

- Scale starts from the Home position (origin) and extends only in the plus direction. The value returns to 0 after making the number of revolutions set by “PS” command.
 - Motor Series: YS, JS1, JS2 and RS
 - Coordinate values range from 0 to $\{614400 \times (\text{PS data}) - 1\}$
 - Motor Series: SS
 - Coordinate values range from 0 to $\{491520 \times (\text{PS data}) - 1\}$
 - Motor Series: AS, BS and JS0
 - Coordinates values range from 0 to $\{409600 \times (\text{PS data}_- - 1)\}$

Figure 8-27: Multi-rotation position scale

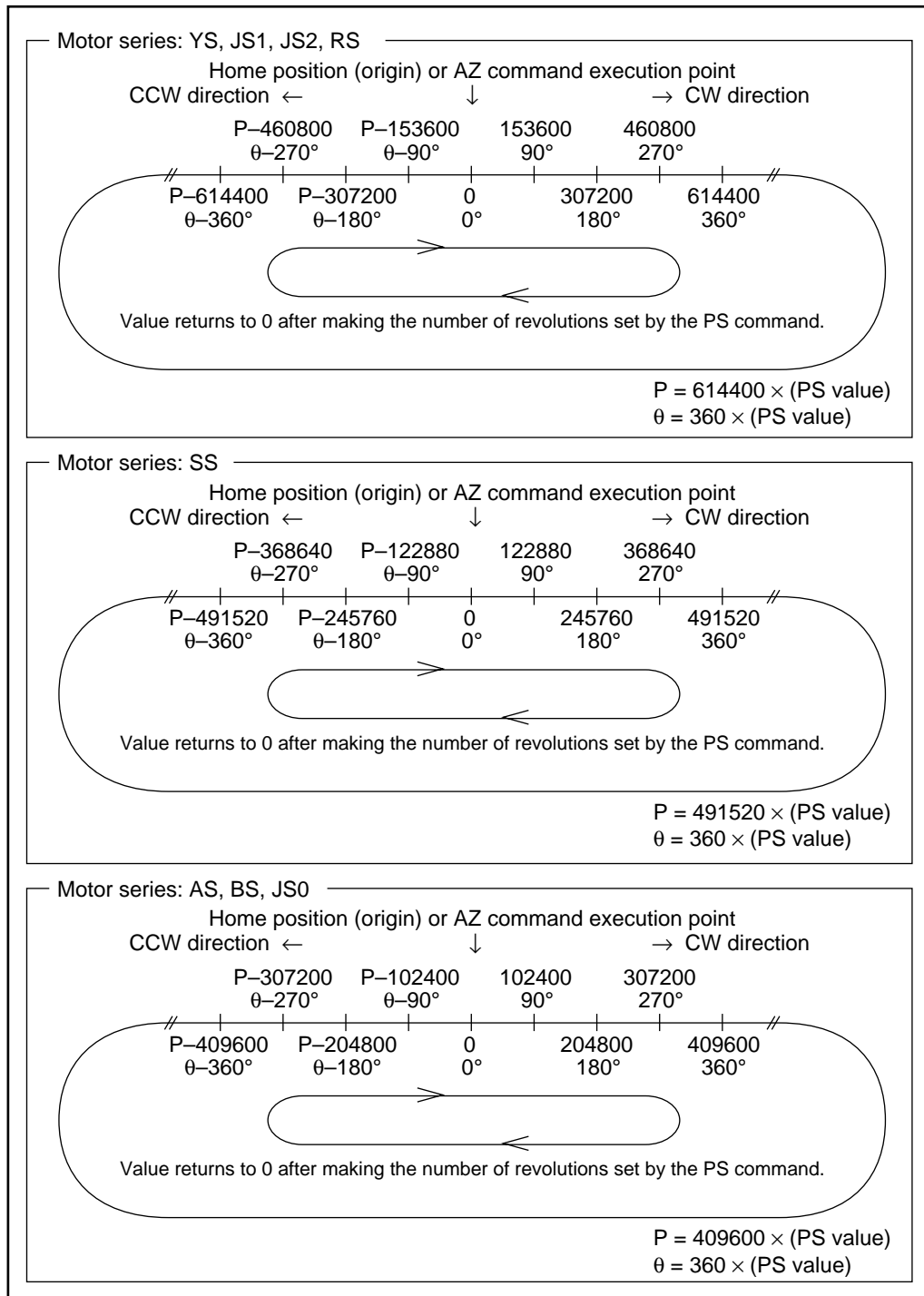

8.2.1.4. Position Scale Reset

Caution : • The position scale value is not decided immediately after the power is turned on. Be sure to reset the position scale before positioning.

- The position scale value is reset to 0 by the following operations.
 - Home Return finish
 - AZ command input

8.1.2.5. Example of Position Scale Setting

(1) Set the CCW direction of the position scale as the plus direction.



Input the password.
The password acknowledgment message appears on the display.

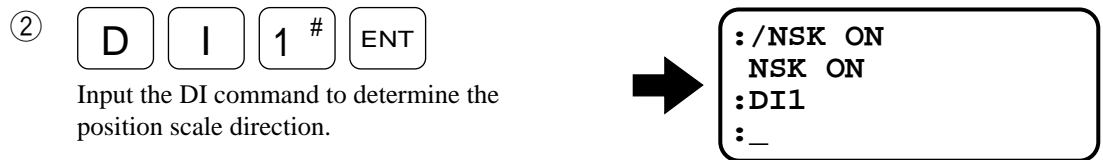

Input the DI command to determine the position scale direction.

(2) Setting the linear position scale



Input the password.
The password acknowledgment message appears on the display.

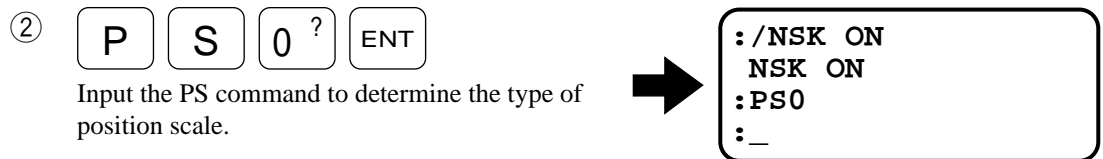

Input the PS command to determine the type of position scale.

(3) Resetting the position scale value



Input the password.
The password acknowledgment message appears on the display.

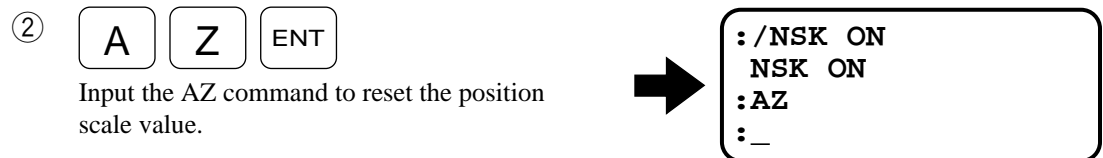

Input the AZ command to reset the position scale value.

8.2.2. Digital Filter

Caution : • Inserting multiple filters may cause phase inversion of velocity loop in some systems, resulting in unstable operation.

- Do not insert more than two filters. Setting a filter frequency too low may cause hunting, etc.; set the frequency to 100 Hz or above.

Parameters for digital filter setting

- Parameters: FP, FS, NP
 - Sets filter frequency in the velocity loop.
 - The filters are useful for eliminating audible noise and vibration due to mechanical resonances.

Table 8-11: Parameter function

Parameter	Function	Shipping set
FP	Sets the primary low-pass filter frequency	FP0
FS	Sets the secondary low-pass filter frequency	FS0
NP	Sets the primary notch filter frequency	NP0

- Refer to Chapter 11 “Command and Parameter” for more details.

Figure 8-28: Digital filter block diagram

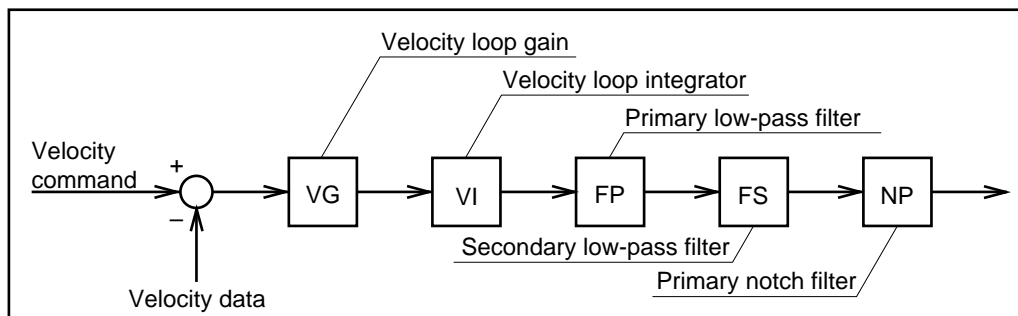

8.2.3. Feed Forward Compensation

- Parameter “FF” sets feed forward compensation gain. The password is necessary when setting.
- Shipping set of “FF” is FF0.
- The feed forward compensation function generates a velocity command by differentiating the position command, then adds it to the velocity loop in the forward direction.
- Feed forward compensation improves follow-up delay during acceleration/deceleration.
- Setting the FF parameter to a higher value improves follow-up delay, but overshoot becomes more likely to occur. It is generally recommended that the parameter be set to 0.5 or below.

Figure 8-29: Feed Forward Compensation Block Diagram

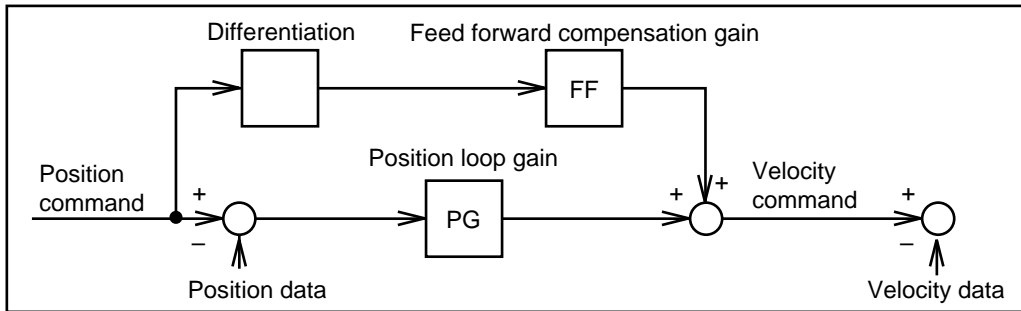

8.2.4. Integrator Limit : ILV

- Parameter “ILV” sets the upper limit to the velocity gain. Shipping set is ILV100.
- The password is necessary when setting “ILV”.
- Integrator limiter reduces overshoot caused by the integrator during high acceleration / deceleration.
- The integrator is indispensable for high-precision positioning. However, when a high-speed acceleration/ deceleration is specified, errors are likely to accumulate so that integration often results in an overshoot. To prevent this, an integrator limiter is provided to restrict an excessive integration.

* For more details about the parameter, refer to “11. Commands and Parameters.”

Figure 8-30: Integrator limiter block diagram

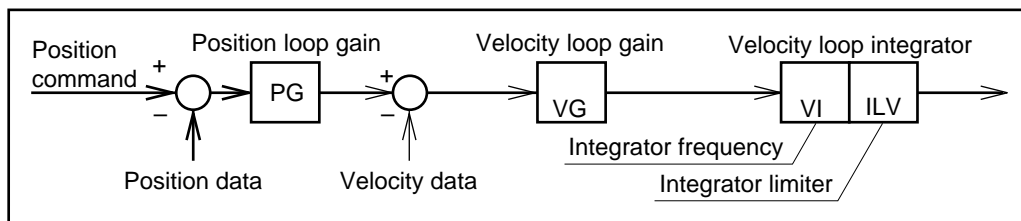
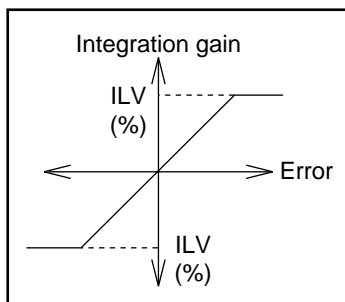

Figure 8-31



8.2.5. Dead Band Setting: DBP

- The DBP parameter sets a dead band, centered at “0” to error in the position loop. When the position error value is below the specified dead band value, the position command is set to 0.
- In some systems, slight vibration may be caused by a slight error in positioning. In this case, slight vibration can be prevented by setting a dead band.
- Setting a dead band reduces microvibrations but lowers repeatability by the set value.
- The dead band is set in the units of pulse (equivalent to the resolver resolution with 12-bit specification: refer to “3.2.3. Function Specifications, Position detector resolution”). When the resolver resolution setting is 10-bit, set the dead band value by a multiple of 4.

Figure 8-32: Dead Band Setting Block Diagram

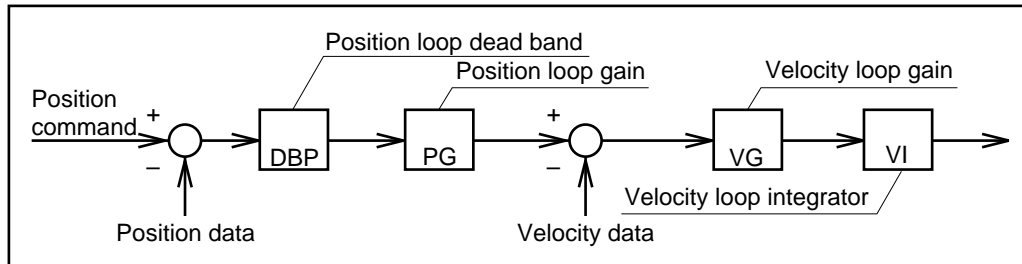

8.3. RS-232C Communication

8.3.1. Specification of Communication

- Setting of various parameters, trial running, and adjustment are enabled by issuing commands to the Driver Units through serial communication (i.e., communication through the RS-232C interface).
- The Driver Unit has CN1 as the input/output ports for RS-232C communication.
- When the Handy Terminal (FHT11) is not in use, set the MM parameter to 0.
 MM1: Standard setting (for the Handy Terminal)
 MM0: For connection with a personal computer

Table 8-12: RS-232C communication specification

Item	Specification
Transmission	Asynchronous, full duplex
Communication speed	9600 b.p.s.
Word length	8 bit
Stop bit	2 bit
Parity	No
Character code	ASCII code
Communication procedure	<ul style="list-style-type: none"> • X-On/Off Protocol: No • RTS/CTS Control: Yes

8.3.2. Communication Procedure

8.3.2.1. When Power is Turned on

- If a terminal (such as NSK Handy Terminal FHT11) is connected to CN1 and the Driver Unit power is turned on, the message shown below is displayed.
- The contents (and the number of characters) of this message may differ with Driver Unit setting and system versions.
- When the Driver Units are initialized, a colon (:) is displayed and the system waits for a command to be entered. (The colon (:) is called a prompt.)

Figure 8-33: Power-on message

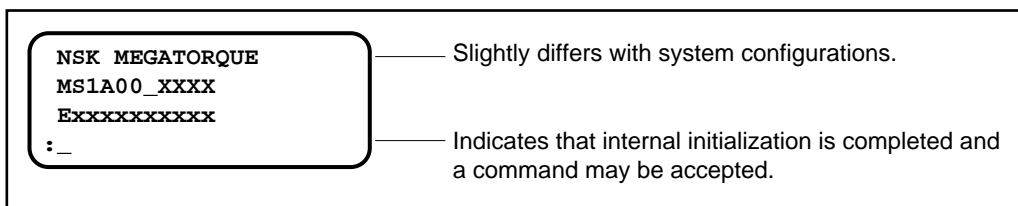

8.3.2.2. Command Entry

- A communication command shall consist of “a command (character string) + data (if necessary) + carriage return code (0DH).”
- If the velocity gain is to be set to 0.5, for example, “VG0.5” should be entered by adding data of 0.5 to a VG command. The characters of this command with data are transmitted to the Driver Unit as shown below:

Figure 8-34: Example Of VG0.5

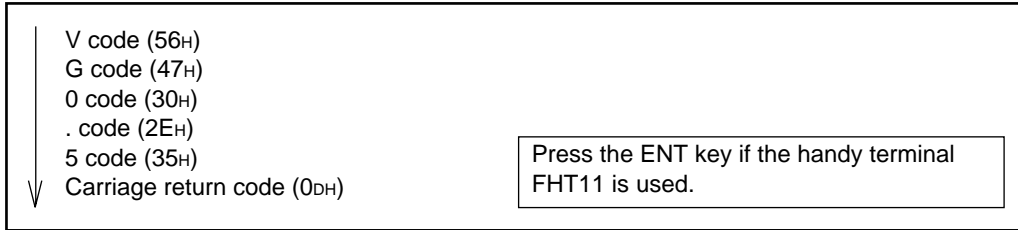

- Every time a character is input, the Driver Unit echoes the character back to the terminal. (The Driver Unit returns the same character that it receives.)
- However, the Driver Unit converts carriage return code to “carriage return code (0DH) + line feed code (0AH),” then returns it to the terminal.
- When a carriage return code is input, the Driver Unit decodes a character string which it has received (VG0.5 in the example above) and executes it. Therefore, a command is not executed unless it ends with a carriage return code.
- If the Driver Unit can decode an entered command, it returns “:” immediately after the line feed code. If it receives a internal data read command, etc., it returns the data before “:”.

Figure 8-35: Successful input example

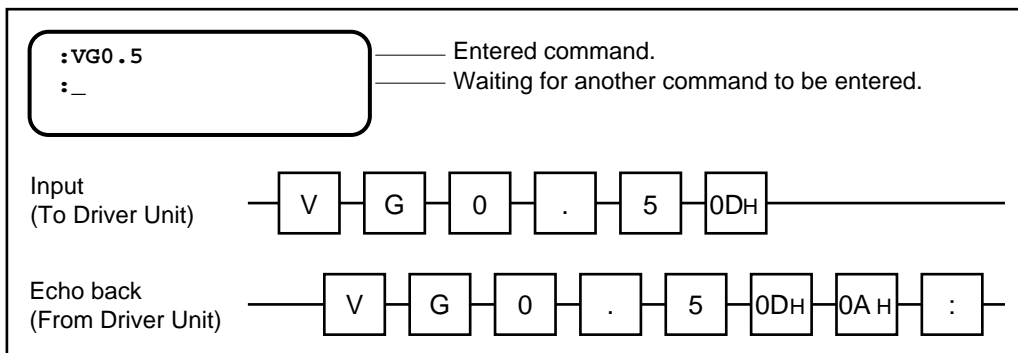

8.3.2.3. Password

- Among the communication commands used for this System, some special commands (such as AB, PA, SI, etc.) require password entry for preventing erroneous entries. These commands cannot be entered in the same manner as other commands.
- The password is /NSK ON (a space between K and O) as shown below. If the Driver Unit accepts it, it returns an “NSK ON” message.
 - Applicable commands: DB, FC, FF, IL, OG, OL, PA, RC, SI, and ZA
- A command requiring password entry may only be executed immediately after the password is entered.

Figure 8-36: Password Example

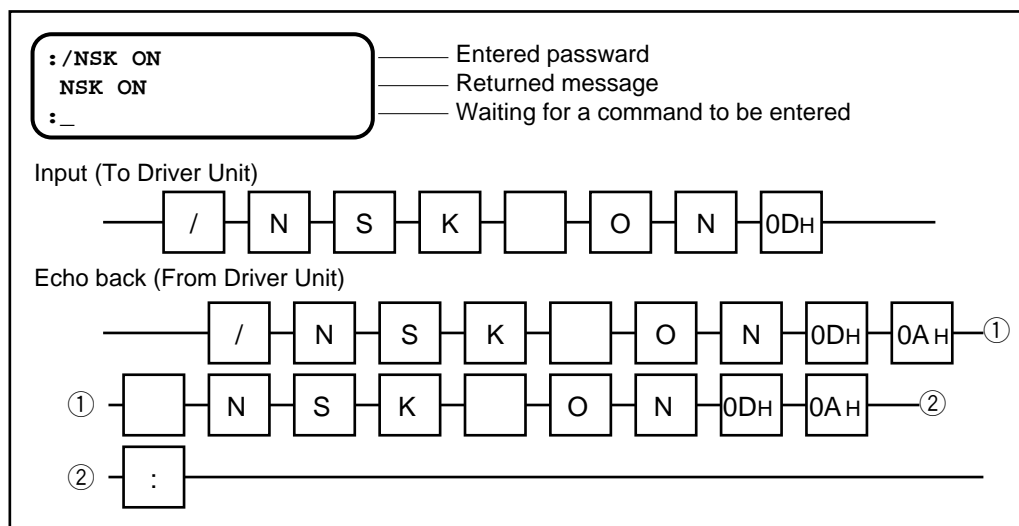

8.3.2.4. Canceling Command

- A command which has been entered halfway, entering a backspace code (08H) can cancel a character or a entered full character string. Parameter “backspace mode” (BM) sets the cancelling method.

BM0: a backspace code cancels an entered character string.

BM1: a backspace code cancels a character.

[When the Handy Terminal FHT11 is used, press the backspace (BS) key.]

(1) Parameter “BM1” (Shipping set)

- For example, when the backspace code is input following VG0.5, the cursor moves one space back to the position where 5 was input and thereby deletes 5.

Figure 8-37: Cancelling example (BM1)

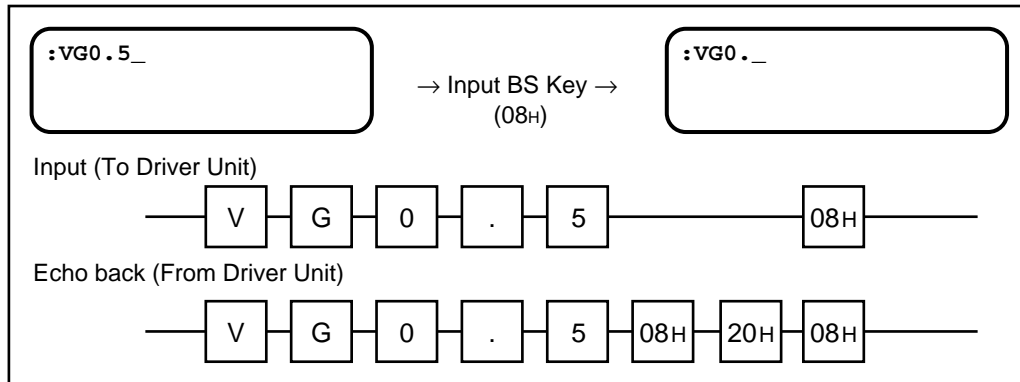

(2) Parameter “BM0”

- For example, when the backspace code is input following VG0.5, a message “VG0.5?” and a colon “:” are displayed and there by delete “VG0.5”.

Figure 8-38: Cancelling example (BM0)

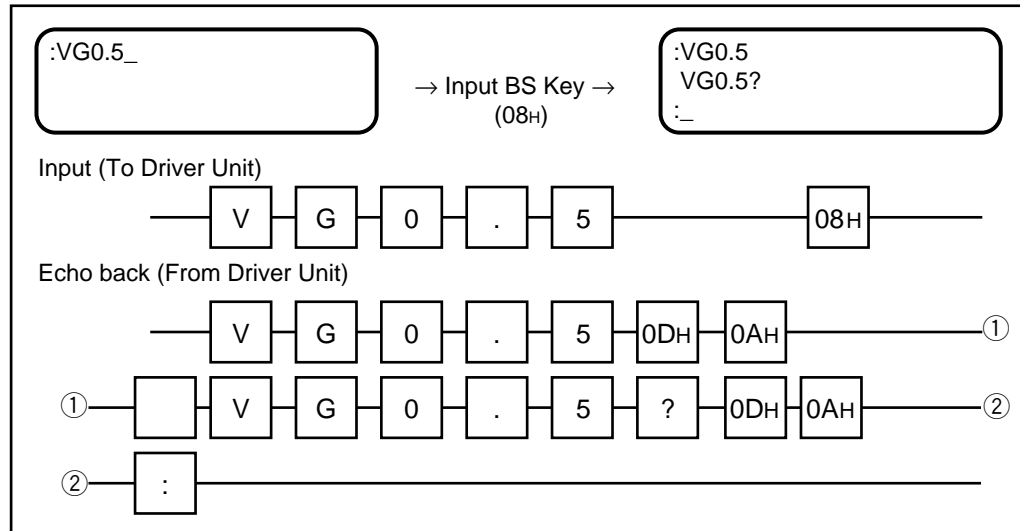

8.3.2.5. Error

- Note that an error occurs in any of the following cases:
 - (1) If a nonexistent command (i.e., character string) is entered (If an entered character string cannot be decoded).
 - (2) If data or subscript out of the allowable range is entered.
 - (3) If a command requiring the password is entered without the password.
 - In any of these cases, the entered character string with a '?' mark is returned as an error message.
 - For example,

Figure 8-39: Input error example 1

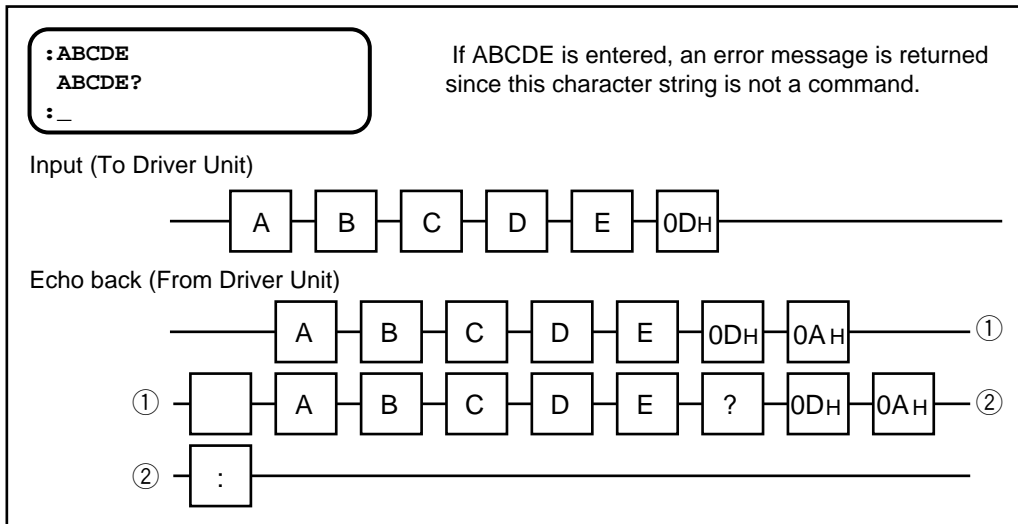

- (4) If the input condition is not met when entering a command.
 - In this case, the entered character string with "INHIBITED" is returned.
 - For Example,

Figure 8-40: Input error example 2

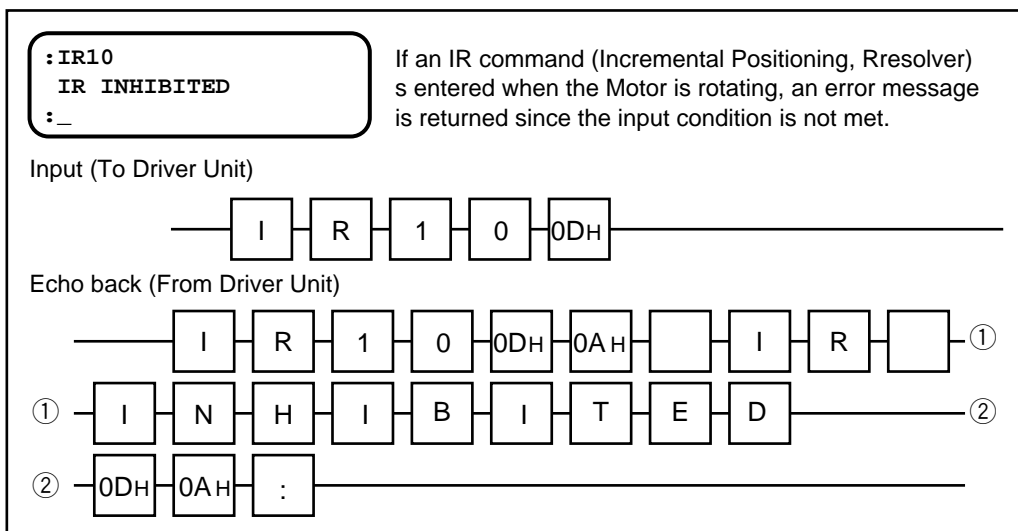

8.3.2.6. Readout Command

- If a command for reading the internal state (i.e., parameter set values, current position, etc.) of the Driver Unit among the communication commands of this system is entered, the Driver Unit returns data, etc.
- Returned data consists of “space code (20H) + read value, data + carriage return (0DH) + line feed code (0AH)”.
 - For example,

(1) TS command for reading set value

Figure 8-41: TS command example

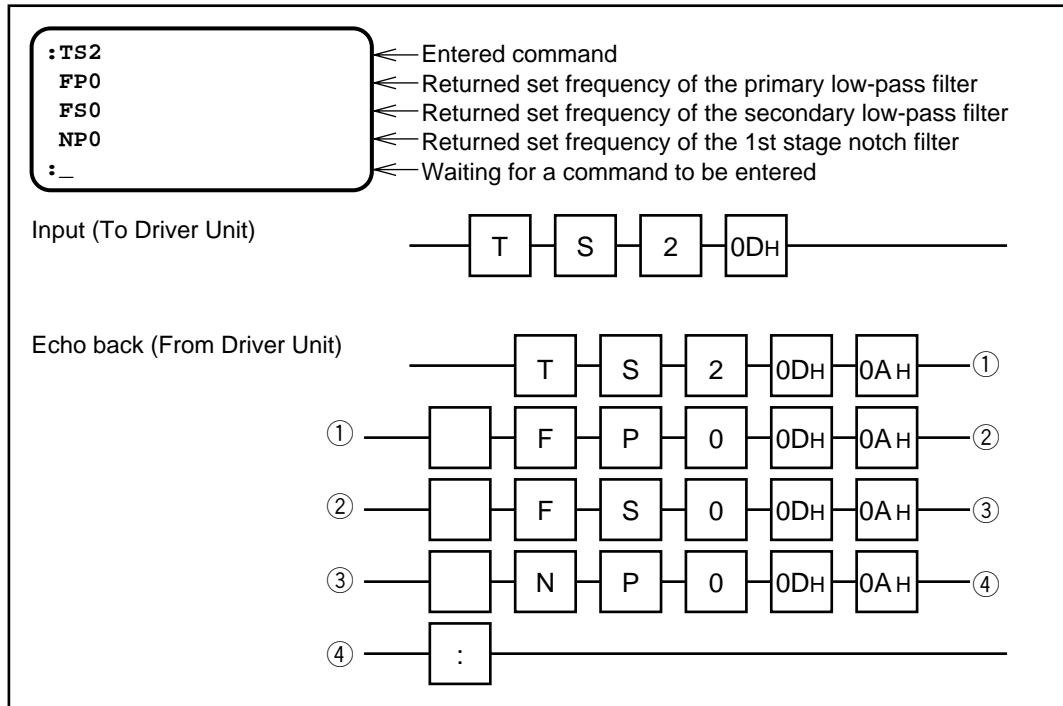

(2) If set value reading function ? is used

Figure 8-42: "?" function example

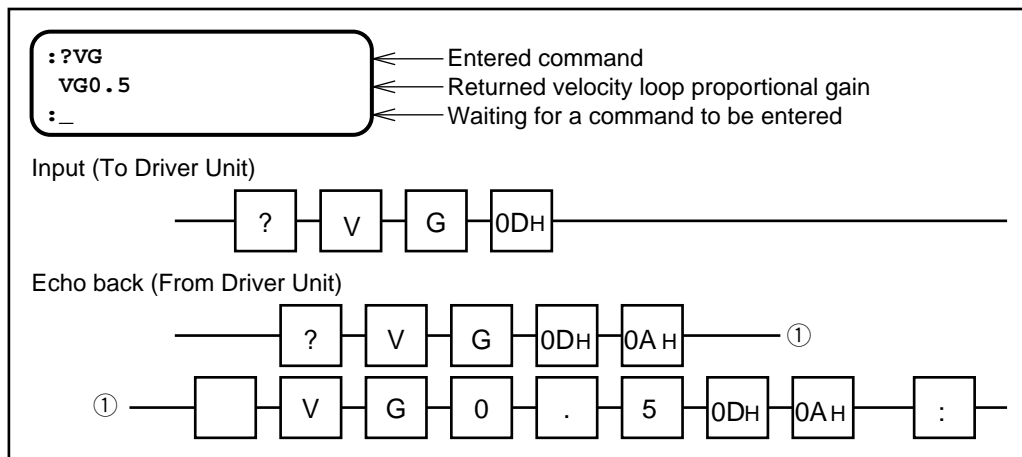

(3) TP command for reading current position data

Figure 8-43: TP command example

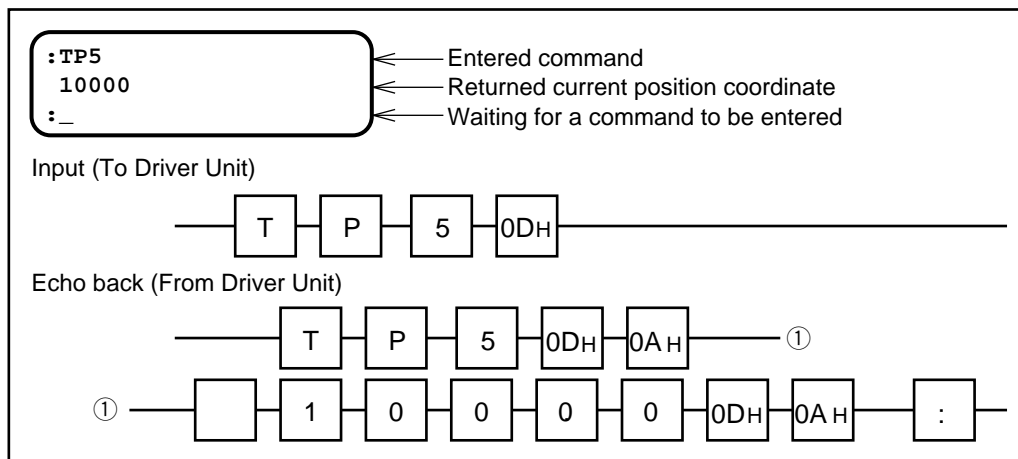

8.3.3. Daisy Chain Communication

- Daisy chain communication allows multiple Driver Units (up to 16 units) to be connected with a single RS-232C terminal.

Figure 8-44: Daisy chain communication overview

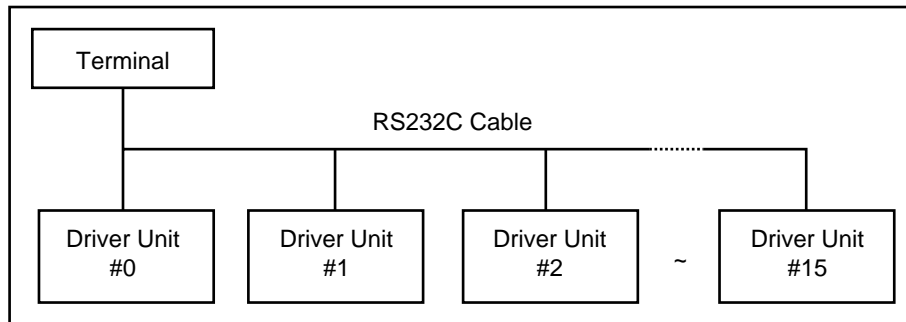

8.3.3.1. Procedure to Set Daisy chain Communication

Figure 8-45: Daisy chain communication setting procedure

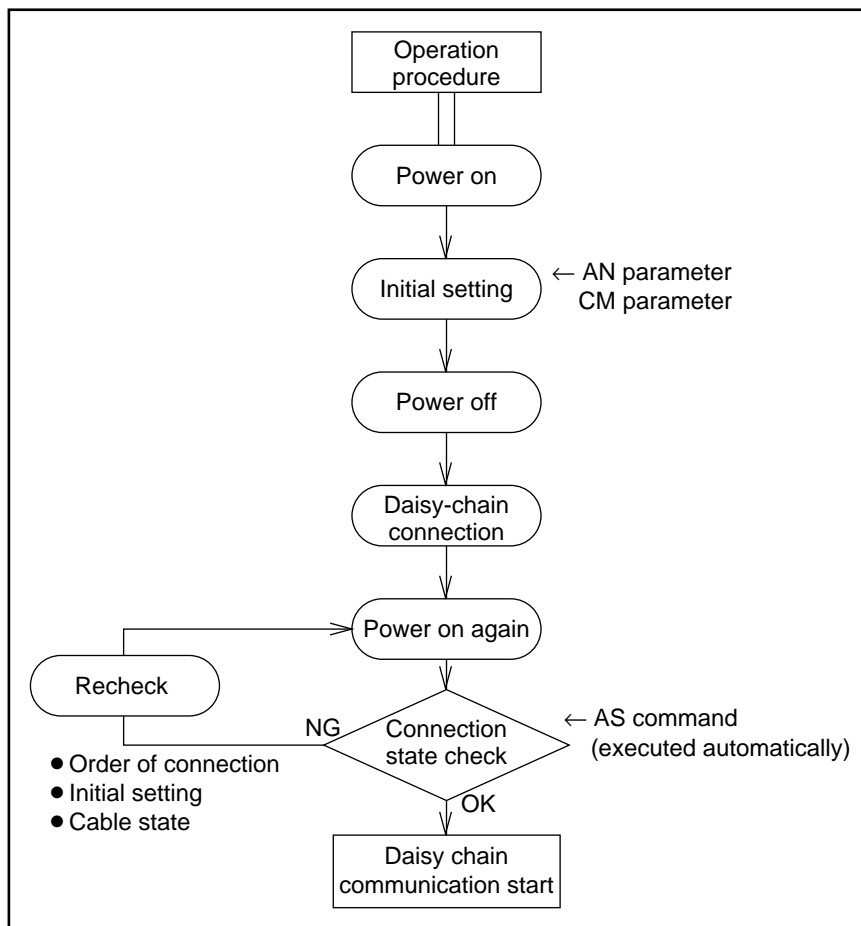

8.3.3.2. Initial Setting

- The password is necessary for inputting initial setting parameters.
- The initial setting values become valid when the power is turned on next time.
- Perform initial setting before making multi-axis connection.

Table 8-13: Initial setting

Item	RS-232C parameter	Data range	Shipping set	Function
Daisy chain communication, axis number setting	AN data	0~15	0	The set data becomes the axis number of multi-axis communication.
Daisy chain communication mode selection	CM data	0, 1	0	CM0: standard (single driver) communication, CM1: daisy-chain communication

8.3.3.3. Interfacing

(1) Connecting data communication lines

- Connect data communication lines sequentially: First connect the output of the terminal with the input of axis 0, then connect the output of axis 0 with the input of axis 1 and so forth. (See Figure 8-45.)
- Connect the output of the final axis with the input of the terminal.

Figure 8-46: Data line connection

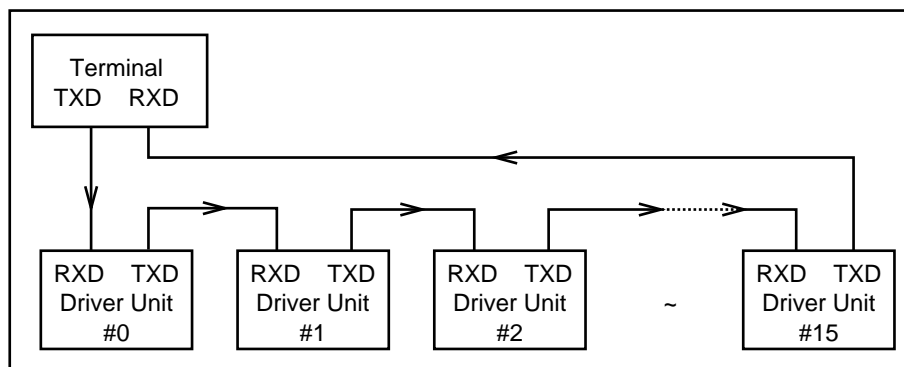

(2) Connecting data transmission request lines

- Connect data transmission request lines sequentially: First connect the input of the terminal with the output of axis 0, then connect the input of axis 0 with the output of axis 1 and so forth. (See Figure 8-46.)
- Connect the input of the final axis with the output of the terminal.

Figure 8-47: Request-to-send Line Connection

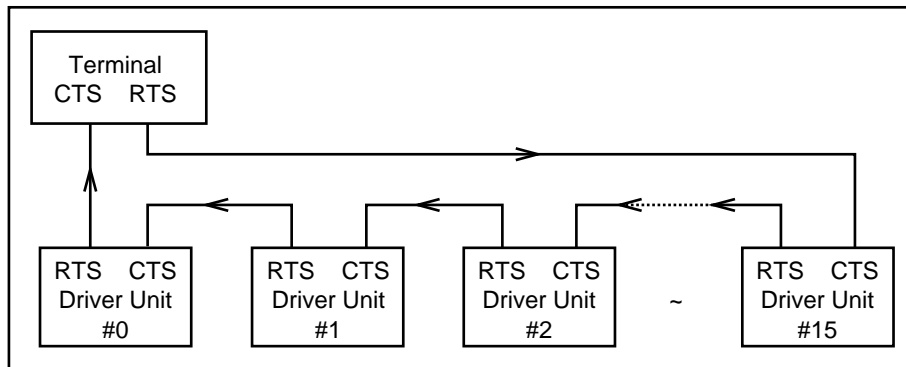

Actual Connection Example

- When NSK's Handy Terminal is in use, connect the lines as shown in Figure 8-47.
- Refer to "4.1. CN1: RS-232C Serial Communication Connector" for the specification of CN1.

Figure 8-48: Handy Terminal Connection Example

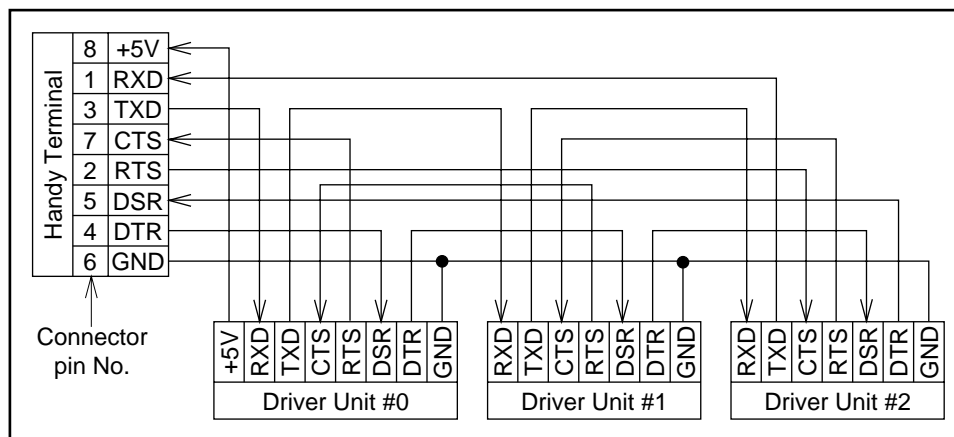

*: The communication signal name on the Handy Terminal is opposite to that on the Driver Unit (e.g. RXD—TXD).

8.3.3.4. Power on

Caution : • If the Handy Terminal is not used, turn on power in the order of the RS-232C terminal and Driver Units.

• Turn on the power for all Drivers simultaneously (if all the axes cannot be turned on at once, be sure to design the system so that the power of the Driver Unit axis No. 0 turns on at the end.)

- When the Driver Unit of axis No.0 is turned on, an AS command is executed to check for connection.
- If all the terminal and units are connected properly, the following message is displayed (the following examples show a 3-axis configuration)

Figure 8-49

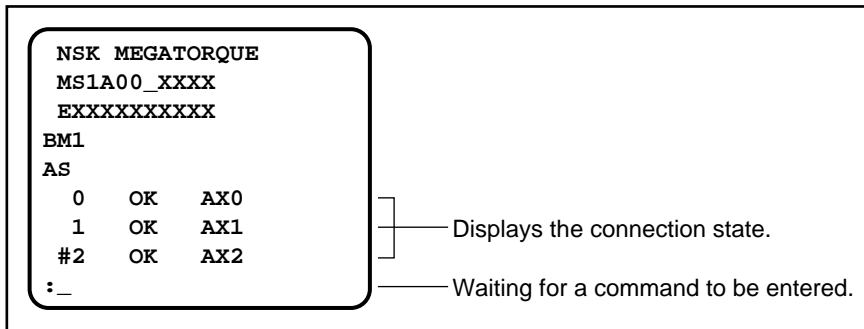

- If connection is improper, the following message may be displayed.
- The following message example shows a case where axis No.1 and axis No.2 are connected improperly.

Figure 8-50

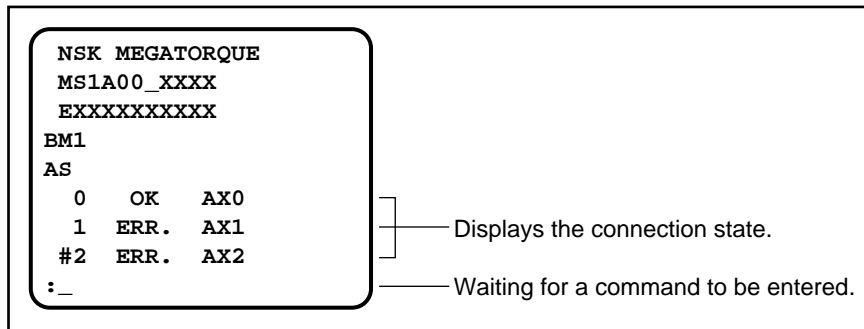

- If the proper message is not displayed, check for connection order, initial settings (AN parameter, CM parameter), and cable connection.

8.3.3.5. Operation

● Selection of Driver Unit to be Communicated

- In daisy chain mode, the RS-232C terminal is capable of communication through a single driver unit.
- Use an AX command to select one of the Driver Units connected for daisy chain communication.

Caution : Do not select any unit that is not connected. Otherwise, operation may hang up. To return to the normal state, press the BS key, then select the number of a connected driver unit.

Figure 8-51

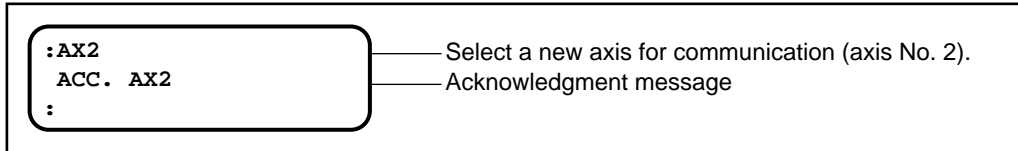

- An axis selected for communication may be checked by issuing a ?AX command. The axis is displayed in the same manner as it is selected.

Figure 8-52

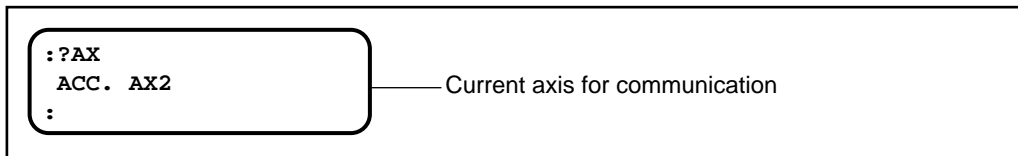

● Example of Daisy-chain Communication

Figure 8-53: Example of Daisy chain Communication

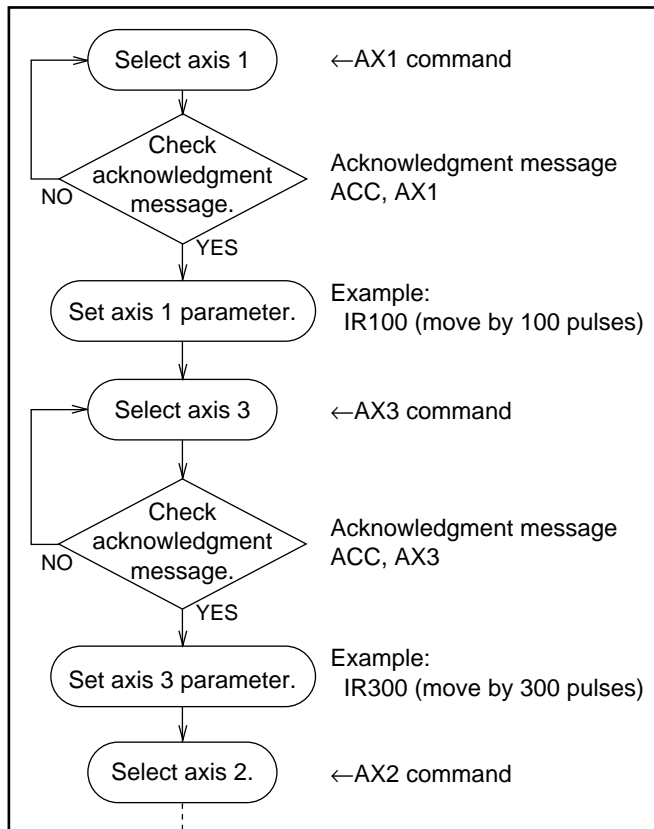

(Blank Page)

9. Operation

9.1. Preparation

9.1.1. Wiring Check

Caution : After completion of all wiring of ESA25 Driver Unit, check followings before operation.

Table 9-1

	Check item	Confirmation
1	Connection of Main power and Input/Output cables	<ul style="list-style-type: none"> • All wiring is properly arranged and completed. • Terminal block screws are securely fastened. • All connectors are connected and locked properly.
2	Cable Set	<ul style="list-style-type: none"> • Cable Set (Motor and Resolver cables) is connected and locked properly.
3	Handy Terminal	<ul style="list-style-type: none"> • Handy Terminal (FHT11) is connected and locked to CN1 connector.

9.1.2. Procedure

Figure 9-1

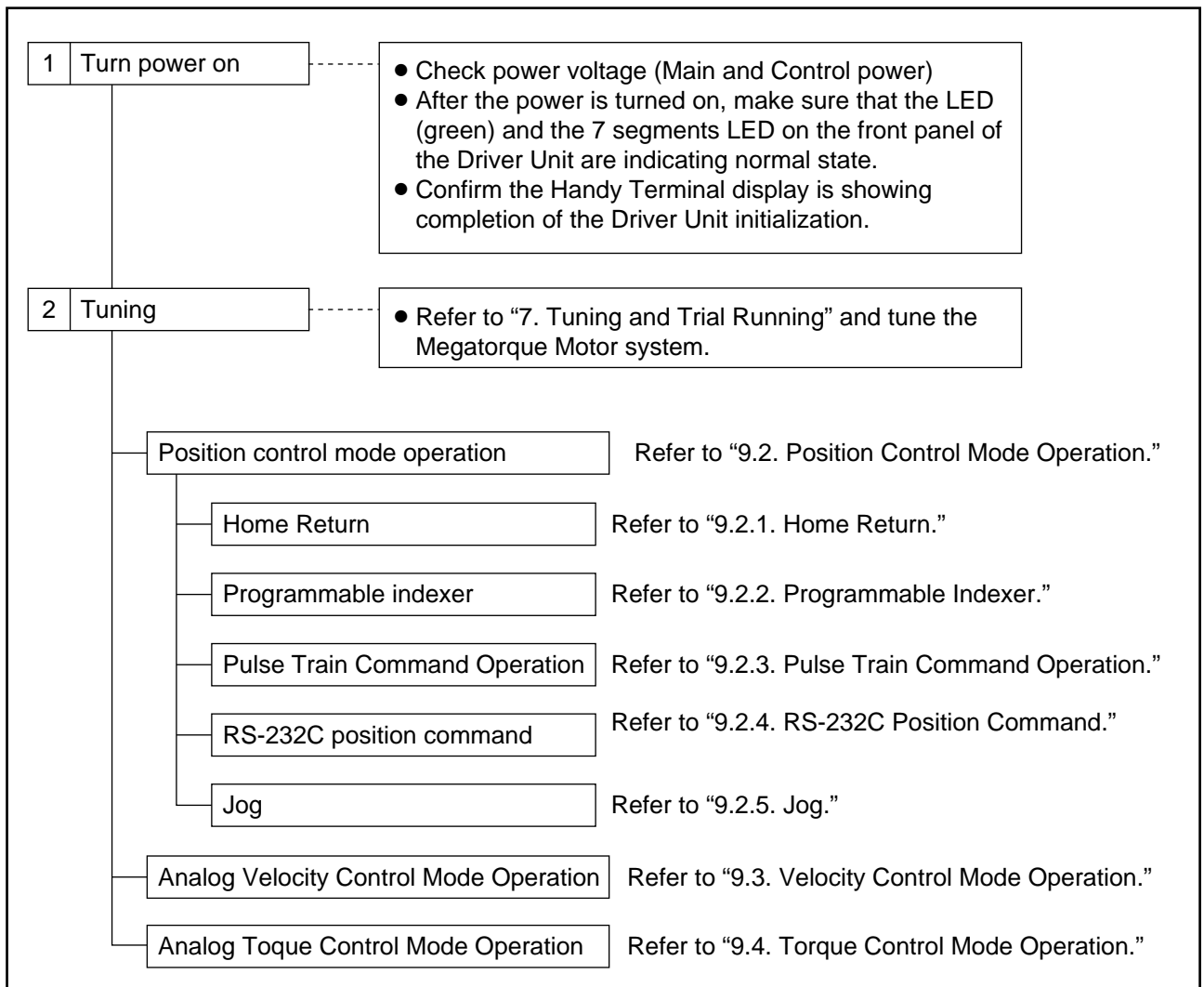

9.2. Position Control Mode Operation

- Select a position control mode with the parameter SL.
 - SL1: Analog torque control mode
 - SL2: Analog velocity control mode
 - SL3: Position control mode
- Following operations are available in the position control mode.
 - Home Return operation
 - Programmable indexer
 - Pulse train command operation
 - RS-232C position command
 - Jog

9.2.1. Home Return

- Be sure to perform Home Return at all times except when user's controller is governing coordinate system control. The Home position (Zero position) cannot be determined unless Home Return is performed.
- The position coordinates and positions of software overtravel limit switch are set to the position scale determined by Home Return.
- The Home position (Zero position) of the position scale is set to the point at where Home Return completes.

Caution : Position data disappears after the power is turned off, so perform Home Return each time you turn on the Driver Unit power.

Figure 9-2: Home Return sequence

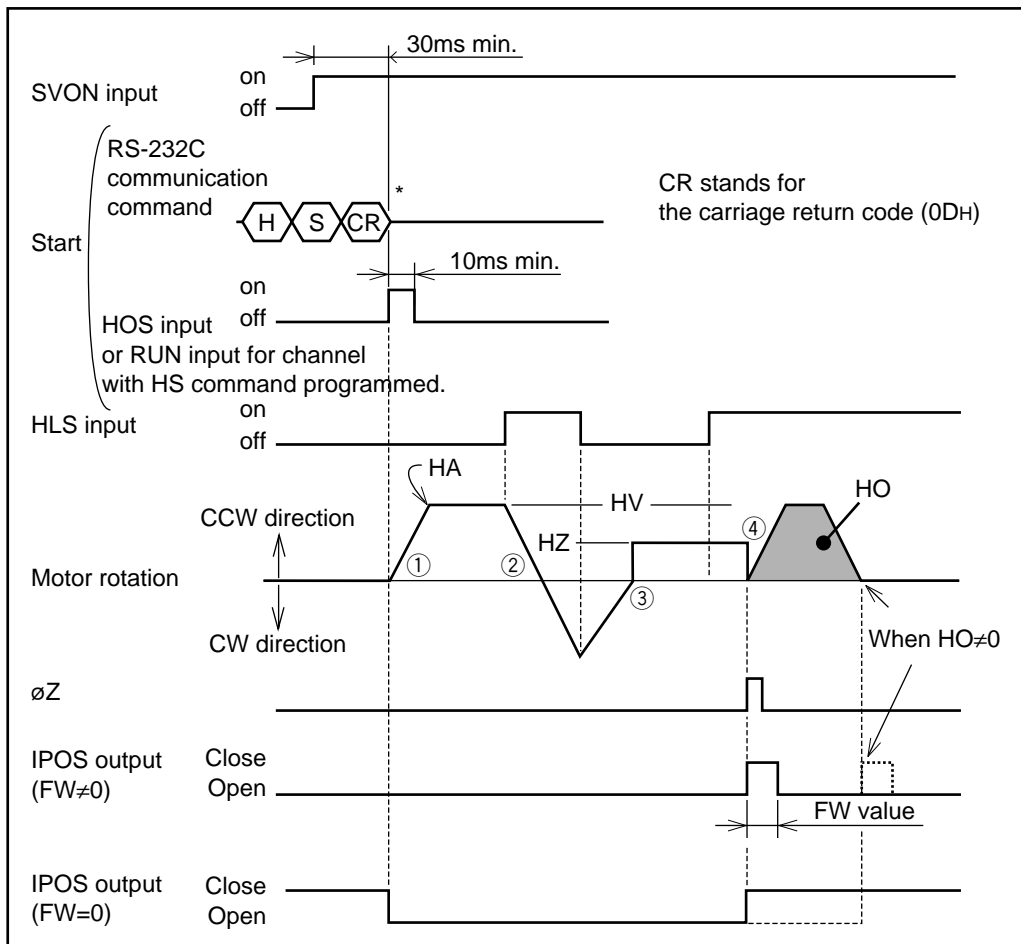

- Make the Motor Servo-on. (SVON input on)
- Turning the HOS input ON will start Home Return. (①)
- The Motor turns CCW*. When it enters HLS (Home position proximity) area (②), it decelerates and stops momentarily, then reverses its rotational direction. (③) The Motor goes out HLS range once, then reverses again and enters HLS area at the Home position search velocity. (④) It moves to the first point where the resolver value becomes 0 (= rising edge of the ϕZ) and completes Home Return.

* The direction of rotation can be changed with the parameter HD (Home Return direction).

HD0: CW

HD1: CCW (Shipping set)

- If the Home offset value HO is set, the Motor moves farther past the resolver 0 point by the offset value, then completes Home Return operation.
- Home Return can be also executed with the following ways.
 - Select the channel where HS command is set and input RUN command.
 - Execute RS command through RS-232 communication.
- Home Return movement differs as shown in Figure 9-3 according to the starting point of Home Return.

Figure 9-3

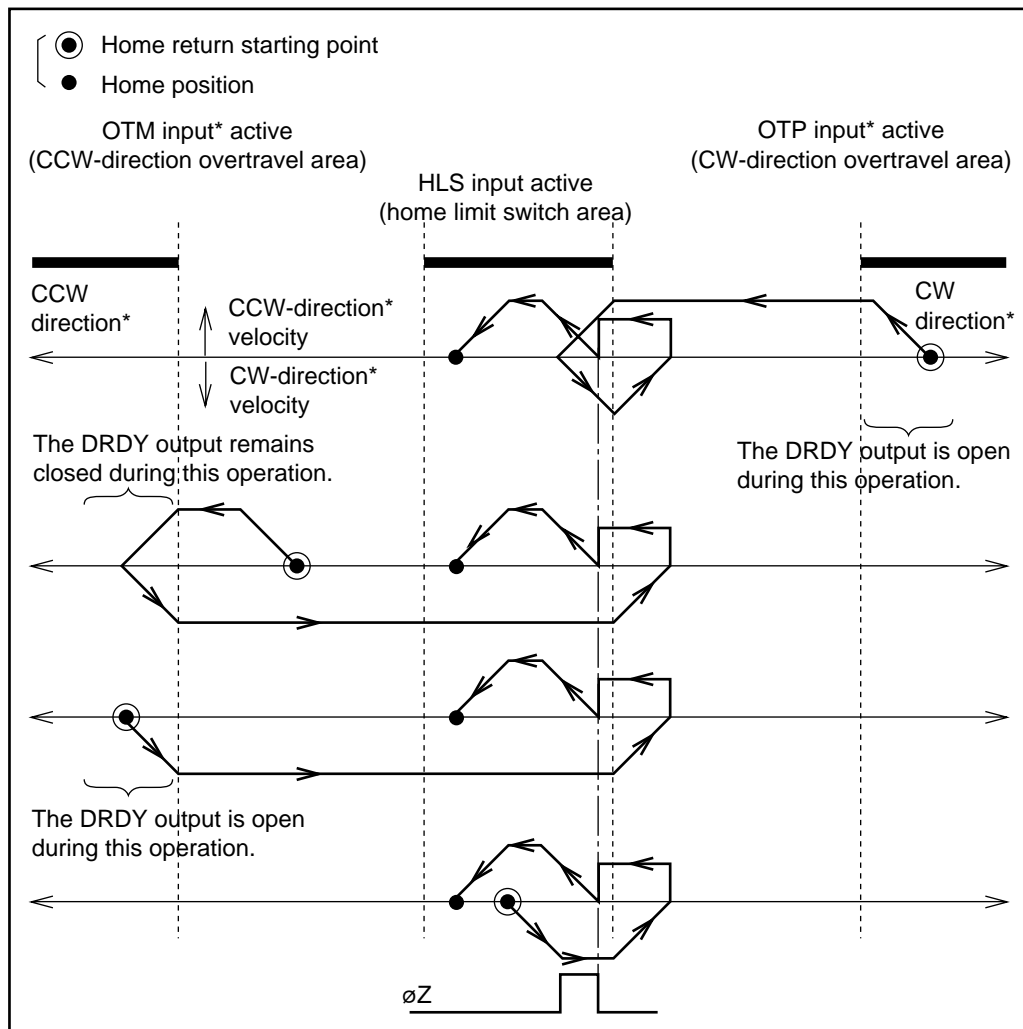

*: When Home Return direction is reversed by the HD parameter, CW and CCW as well as OTP and OTM are reversed as follows: CW → CCW, OTP → OTM.

9.2.1.1. Home Return Parameter List

Table 9-2: Motor series: YS, JS1, JS2 and RS

Parameter function	RS-232C Parameter	Unit	Data input range	Shipping set
Home Return Acceleration	HA	r.p.s./s	0.01~40.00	1.00
Home Return Velocity	HV	r.p.s.	0.01~3.00	0.2
Home Position Offset	HO	pulse	0~610304	0
Home Return Direction	HD	—	0: CW, 1: CCW	1
Home Return Near-Zero Velocity	HZ	r.p.s.	0.01~0.20	0.01

Table 9-3: Motor series: SS

Parameter function	RS-232C Parameter	Unit	Data input range	Shipping set
Home Return Acceleration	HA	r.p.s./s	0.01~50.00	1.00
Home Return Velocity	HV	r.p.s.	0.01~3.75	0.2
Home Position Offset	HO	pulse	0~487424	0
Home Return Direction	HD	—	0: CW, 1: CCW	1
Home Return Near-Zero Velocity	HZ	r.p.s.	0.01~0.25	0.01

Table 9-4: Motor series: AS, BS and JS0

Parameter function	RS-232C Parameter	Unit	Data input range	Shipping set
Home Return Acceleration	HA	r.p.s./s	0.01~60.00	1.00
Home Return Velocity	HV	r.p.s.	0.01~4.50	0.2
Home Position Offset	HO	pulse	0~405504	0
Home Return Direction	HD	—	0: CW, 1: CCW	1
Home Return Near-Zero Velocity	HZ	r.p.s.	0.01~0.30	0.01

9.2.1.2. Adjusting Home Position Switch and Home Offset Value

- The position of the Home position sensor (a dog or a sensor) must be adjusted properly to perform Home Return accurately.
- The Home position is determined at the point at where the resolver value becomes zero after detection of HLS input rising edge when motor is running under Home Return near-zero velocity.
- The resolver has many teeth for detecting its position and the rising edge of HLS is to identify a tooth out of these teeth. To make precise detection of ϕZ , the Home limit switch position must be adjusted so that the HLS input goes high when the switch is at the middle center of the tooth width. Design the Home limit switch so that it can be adjusted $\pm 1.2^\circ$ or more in relation to the tooth width.
- Take the following steps to adjust the position of the Home limit switch.

<Operation> Adjusting the Home limit switch position

- (1) Loosely mount the HLS sensor (Home limit switch) slightly preceding a point to be the Home position.
- (2) Check the wiring of the HLS sensor. Execute the IO command and check if the ESA25 Driver Unit is reading the HLS input correctly.
- (3) Adjust the position of the Home position sensor. First, make the Motor servo-on, then execute the HS/LS command. At this time, be careful that the Motor starts Home Return operation and thereby rotates. By using Handy Terminal, take the following steps:

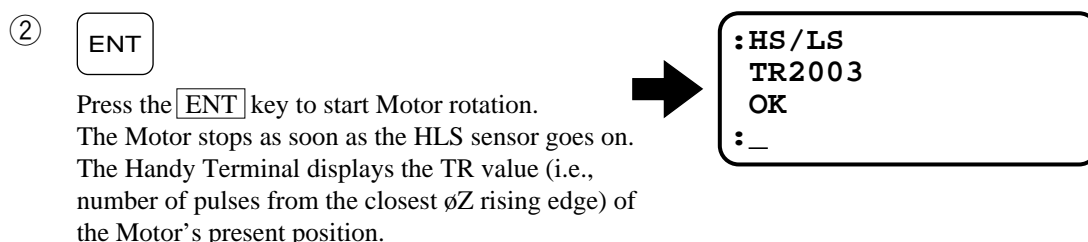
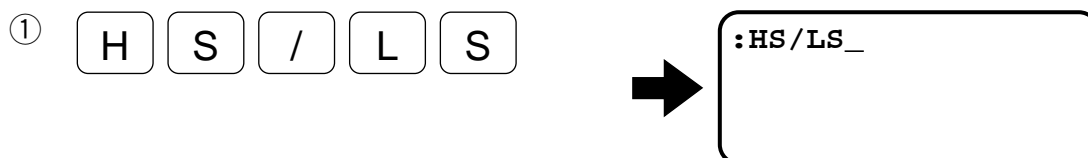

Check that this value is in the range between 1000 and 3000

If the TR value is not in this range, loosen the HLS sensor and move it CW or CCW direction.
Repeat steps ① and ② until the TR value is within the above range.

Caution: When installing the HLS sensor, be sure to adjust its position as mentioned above. Otherwise, positioning may not be performed correctly.

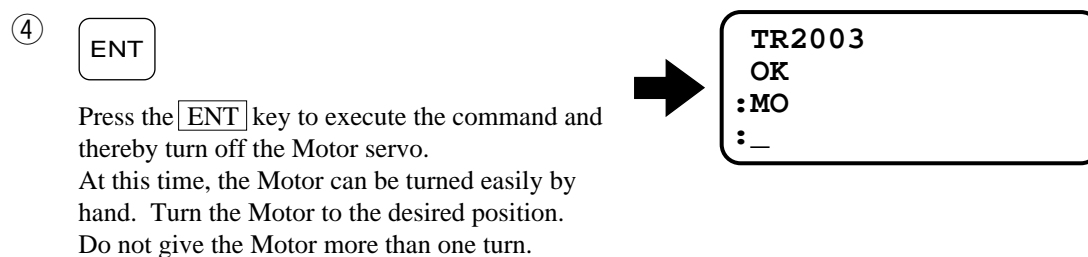
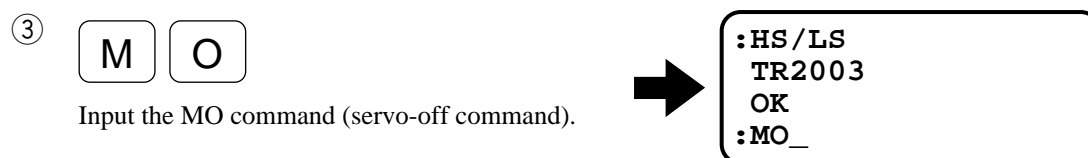

- ⑤ Input the password.
- / N S K SP
- O N
- ➔
- ```
TR2003
OK
:MO
: /NSK ON_
```
- ⑥
- ENT
- ➔
- ```
:MO
: /NSK ON
NSK A command can be
: _ entered only on this line
```
- ⑦
- H O / S T
- Input the HO/ST command.
- ➔
- ```
:MO
: /NSK ON
NSK ON
:HO/ST_
```
- ⑧
- ENT
- Press the **ENT** key to execute the command. When the “:” colon appears on the display, Home offset HO value is automatically calculated and set.
- ➔
- ```
NSK ON
:HO/ST
HO1234
:_
```
- ⑨ Input the SV command (servo-on command.)
- S V
- ➔
- ```
NSK ON
:HO/ST
HO1234
:SV_
```
- ⑩ Press the **ENT** key to execute the command and there by turn on the Motor servo.
- ENT
- ➔
- ```
:HO/ST
HO1234
:SV
:_
```
- The “:” colon appears when the Driver Unit is ready to accept another input.
- ⑪ Input the HS command (Home Return start command).
- H S
- ➔
- ```
:HO/ST
HO1234
:SV
:HS_
```
- ⑫ Press the **ENT** key to execute the command and there by start Home Return operation.
- ENT
- ➔
- ```
HO1234
:SV
:HS
:_
```
- Check that the Motor stops at the desired Home position.

9.2.2. Programmable Indexer

- Positioning command can be stored to the channel of the Driver Unit. Programmable Indexer is to execute the stored positioning program by selecting the channel via PRG0~PRG3 input and RUN command.
- Set the system to servo-on. (SVON input ON)
- Select the channel. (Input PRG0~PRG3, CN2 signal)
- By inputting RUN command ON, the Motor execute stored positioning program while IPOS output is closed. (When FW=0)
- While the Motor is performing the positioning operation, the RUN input is ignored.
- Input the command “SP” to execute the Programmable Indexer. (Same function as inputting RUN command ON.)

Type



to execute the channel “m” program. (m: channel number)

Figure 9-4: Programmable indexer command timing

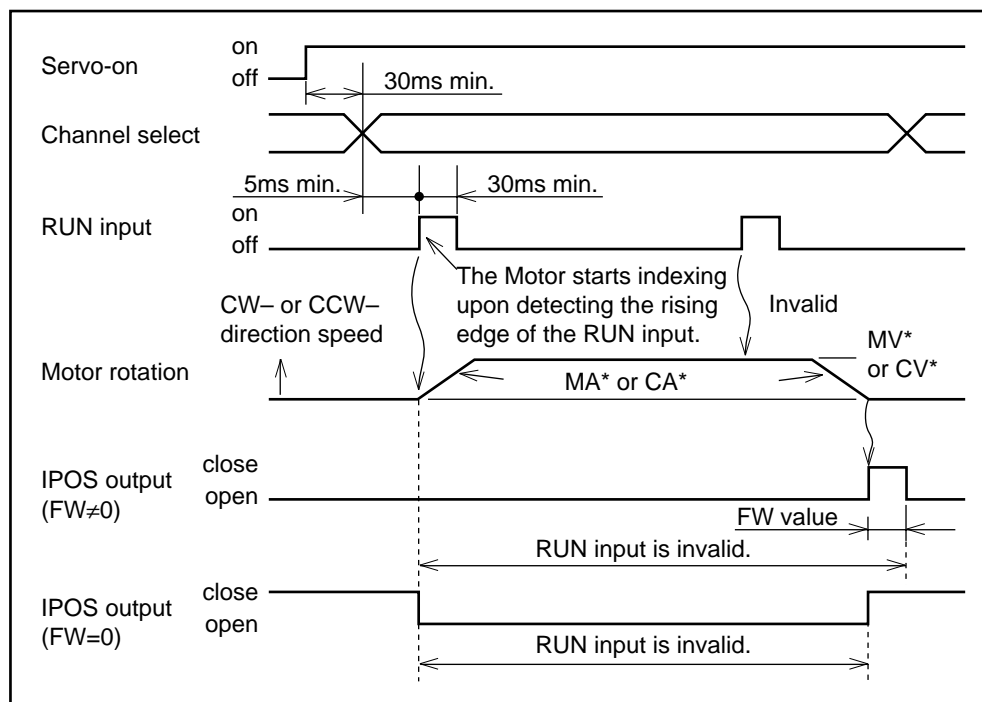

- When a non-programmed channel is selected, the program error alarm will be ON. (Refer to “13. Alarms”)

9.2.2.1. Programmable Indexer Channel Switching

- The channel to be executed is selected by combining the on and off of the PRG0 to PRG5 input of I/O connector CN5.

Table 9-5

(●: ON ○: OFF)

Channel input	PRG 5	PRG 4	PRG 3	PRG 2	PRG 1	PRG 0
Channel 0	○	○	○	○	○	○
Channel 1	○	○	○	○	○	●
Channel 2	○	○	○	○	●	○
.
.
.
Channel 61	●	●	●	●	○	●
Channel 62	●	●	●	●	●	○
Channel 63	●	●	●	●	●	●

9.2.3. Pulse Train Command Operation

9.2.3.1. Pulse Train Signal Format

- Input a pulse train from CWP and CCWP of CN2 control I/O signal connector.
- Set the pulse train input signal format with the PC parameter (via RS-232C communication). (The password must be input prior to the PC parameter setting.)

Table 9-6: Signal format

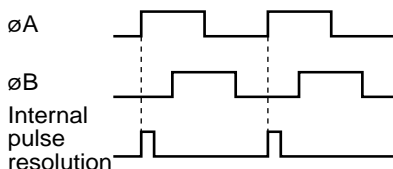
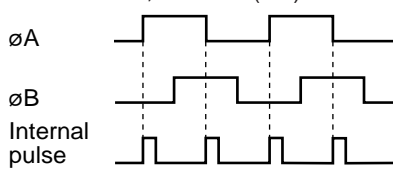
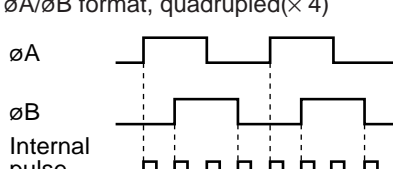
PC Parameter	CWP input	CCWP input	Function
PC0 (shipping set)	• Input CW pulse.	• Input CCW pulse.	CW & CCW format
PC1	• Input the direction. ON : CCW OFF : CW	• Input pulse train	Pulse & direction format
PC2	• Input ϕB	• Input ϕA	$\phi A/\phi B$ format ($\times 1$) 
PC3			$\phi A/\phi B$ format, doubled ($\times 2$) 
PC4			$\phi A/\phi B$ format, quadrupled ($\times 4$) 

9.2.3.2. Pulse Train Resolution

- Set the resolution of the pulse train with the CR parameter (via RS-232C).
- In the case of $\phi A/\phi B$ input, the pulse train resolution is multiplied by the PC parameter value, then by the CR parameter value.
- Refer to Table 9-7 for the concrete data of resolution.

Figure 9-5: Pulse train resolution setting

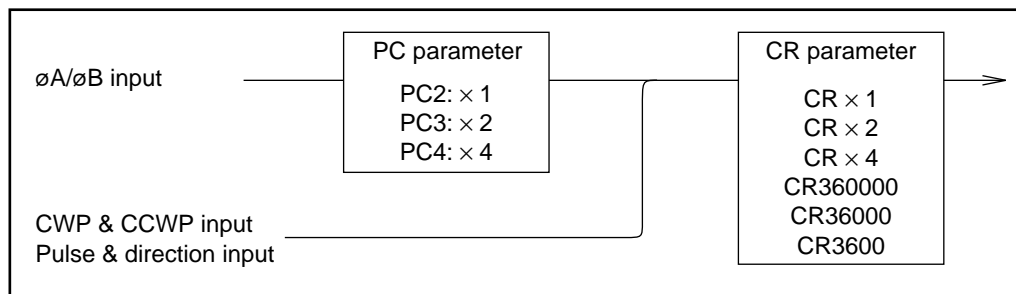

(1) YS, JS1, JS2 and RS Motor series

Table 9-7: Pulse train resolution (YS, JS1, JS2 and RS Motor series)

CR Parameter	Resolver resolution	Resolution (pulses/360°) = number of pulses necessary for giving the Motor one turn		
		CW & CCW format, Step & Direction format	$\phi A/\phi B$ format	
CR × 1 (Shipping set)	12-bit or automatic resolution switching	614400	× 1	614400
			× 2	307200
			× 4	153600
	10bit	153600	× 1	153600
			× 2	76800
			× 4	38400
CR × 2	12-bit or automatic resolution switching	307200	× 1	307200
			× 2	153600
			× 4	76800
	10bit	76800	× 1	76800
			× 2	38400
			× 4	19200
CR × 4	12-bit or automatic resolution switching	153600	× 1	153600
			× 2	76800
			× 4	38400
	10bit	38400	× 1	38400
			× 2	19200
			× 4	9600
CR360000	12-bit/10-bit automatic resolution switching	360000	× 1	360000
			× 2	180000
			× 4	90000
CR36000	12-bit/10-bit automatic resolution switching	36000	× 1	36000
			× 2	18000
			× 4	9000
CR3600	12-bit/10-bit automatic resolution switching	3600	× 1	3600
			× 2	1800
			× 4	900

(2) **SS Motor series**

Table 9-8: Pulse train resolution (SS Motor series)

CR Parameter	Resolver resolution	Resolution (pulses/360°) = number of pulses necessary for giving the Motor one turn		
		CW & CCW format, Step & Direction format	øA/øB format	
CR × 1 (Shipping set)	12-bit or automatic resolution switching	491520	× 1	491520
			× 2	245760
			× 4	122880
	10bit	122880	× 1	122880
			× 2	61440
			× 4	30720
CR × 2	12-bit or automatic resolution switching	245760	× 1	245760
			× 2	122880
			× 4	61440
	10bit	61440	× 1	61440
			× 2	30720
			× 4	15360
CR × 4	12-bit or automatic resolution switching	122880	× 1	122880
			× 2	61440
			× 4	30720
	10bit	30720	× 1	30720
			× 2	15360
			× 4	7680
CR360000	12-bit/10-bit automatic resolution switching	360000	× 1	360000
			× 2	180000
			× 4	90000
CR36000	12-bit/10-bit automatic resolution switching	36000	× 1	36000
			× 2	18000
			× 4	9000
CR3600	12-bit/10-bit automatic resolution switching	3600	× 1	3600
			× 2	1800
			× 4	900

(3) **AS, BS and JS0 Motor series**

Table 9-9: Pulse train resolution (AS, BS and JS0)

CR Parameter	Resolver resolution	Resolution (pulses/360°) = number of pulses necessary for giving the Motor one turn		
		CW & CCW format, Step & Direction format	øA/øB format	
CR × 1 (Shipping set)	12-bit or automatic resolution switching	409600	× 1	409600
			× 2	204800
			× 4	102400
	10bit	102400	× 1	102400
			× 2	51200
			× 4	25600
CR × 2	12-bit or automatic resolution switching	204800	× 1	204800
			× 2	102400
			× 4	51200
	10bit	51200	× 1	51200
			× 2	25600
			× 4	12800
CR × 4	12-bit or automatic resolution switching	102400	× 1	102400
			× 2	51200
			× 4	25600
	10bit	25600	× 1	25600
			× 2	12800
			× 4	6400
CR360000	12-bit/10-bit automatic resolution switching	360000	× 1	360000
			× 2	180000
			× 4	90000
CR36000	12-bit/10-bit automatic resolution switching	36000	× 1	36000
			× 2	18000
			× 4	9000
CR3600	12-bit/10-bit automatic resolution switching	3600	× 1	3600
			× 2	1800
			× 4	900

Note: ● In the øA/øB format, one cycle of either øA or øB is defined as “one pulse”.

Figure 9-6

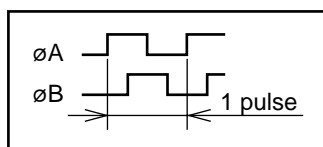

- The resolver resolution is set by the RR parameter (via RS-232C).

9.2.3.3. Input Timing

Caution : The following specifies the conditions of pulse acceptance timing. Besides these conditions, the Motor operation is restricted by the maximum velocity. Do not input pulses faster than Motor's maximum velocity.

(1) When PC is set to "0" (PC0)

Figure 9-7

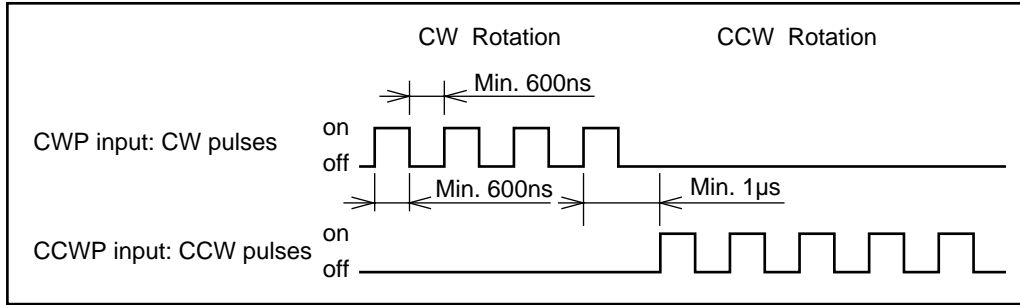

(2) When PC is set to 1 (PC1)

Figure 9-8

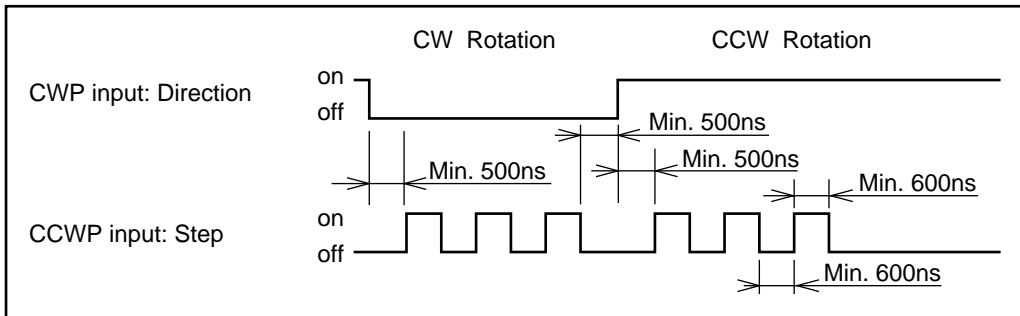

(3) When PC is set to 2~4 (PC2~PC4)

Figure 9-9

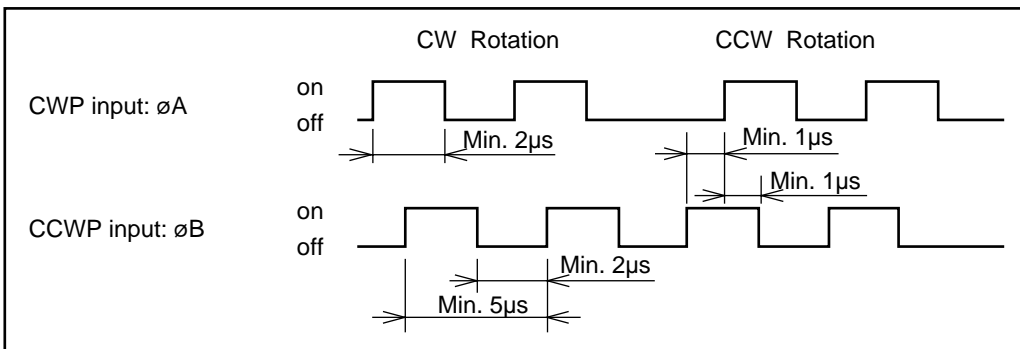

9.2.4. RS-232C Position Commands

- You can execute indexing using RS-232C commands. The commands/parameters are shown below. Refer to “13. Commands and Parameters” for more details.

Table 9-10

Command/parameter	Function
ID command	Sets the target and executes rotation (incremental/in the units of degree)
IR command	Sets the target and executes rotation (incremental/in the units of pulse)*
AD command	Sets the target and executes rotation (absolute/in the units of degree)
AR command	Sets the target and executes rotation (absolute/in the units of pulse)*
HS command	Starts Home Return.
HV parameter	Sets Home Return velocity.
HA parameter	Sets Home Return acceleration.
HO parameter	Sets the home offset value.
HD parameter	Specifies Home Return direction.
MA parameter	Sets the acceleration, for indexing.
MV parameter	Sets the velocity, for indexing.

*: The table below lists the number of pulses per rotation of the IR command.

Table 9-11: Motor type and resolution

Motor series	Resolution [pulses/rotation]
YS, JS1, JS2, RS	614400
SS	491520
AS, BS, JS0	614400

● Indexing Timing

Figure 9-10: Indexing timing

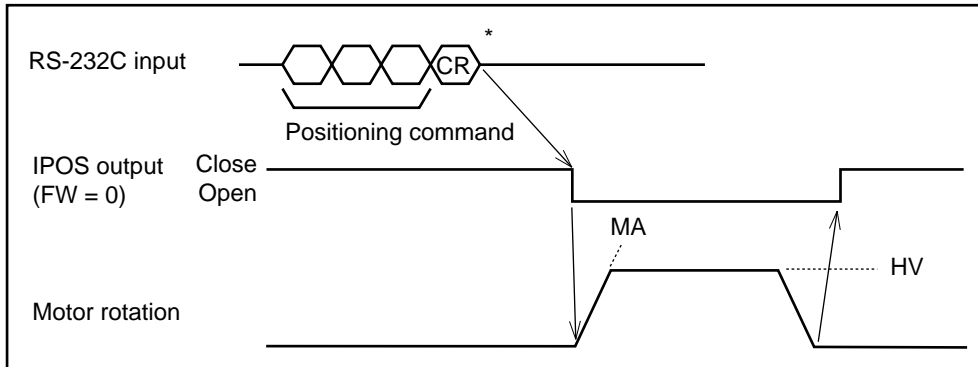

*: CR stands for the carriage return code (0DH).

- Under SVON state, as soon as the command is input, the Motor starts indexing. The acceleration and velocity follow the settings of parameters “MA” and “MV”.
- If the position error counter value is within the in-position limit (set by IN parameter) after indexing, the IPOS output should be closed.

9.2.5. Jog Operation

- Set system to servo-on. (SVON input ON)
- Turning on the Jog input makes the Motor start acceleration and rotation. The Motor keeps rotating while the Jog input remains on. When the Jog input is off, the Motor starts decelerating, then stops.
- When the DIR input is off, the Motor turns CW. When the DIR input is on, it turns CCW.
- Jog operation parameter
 - JA: Jog acceleration
 - JV: Jog velocity

Figure 9-11: Jog operation timing

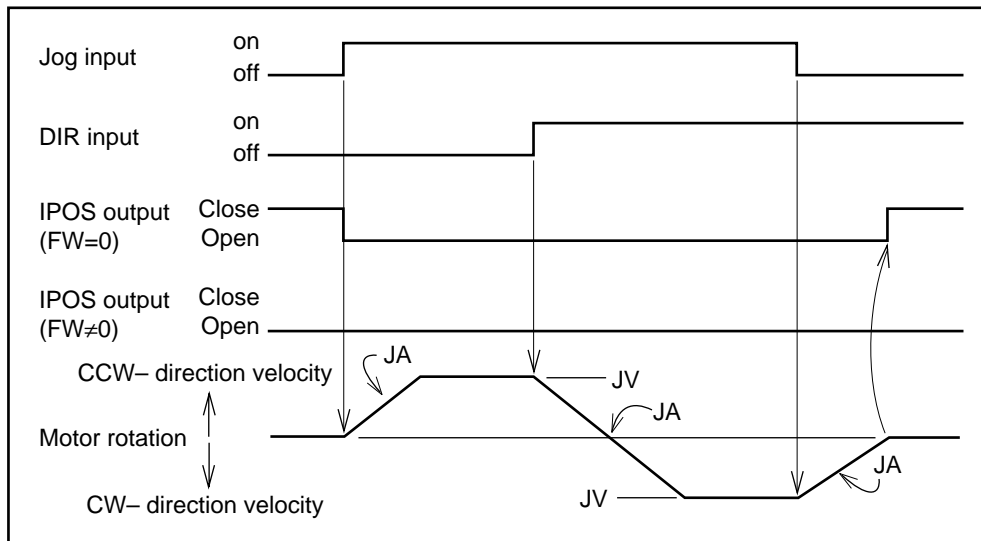

Note: When the DIR input is switched during Motor rotation as shown in the above chart, the Motor decelerates, then reverses the direction of rotation.

9.3. Velocity Control Mode Operation

- Velocity control mode can be set with the SL parameter.
 - SL1: Torque control mode
 - SL2: Velocity control mode
 - SL3: Position control mode
- Velocity control mode is available in the analog command input or RS-232C command input.
- The mode is switched by the parameter AC.
 - AC0 : Analog command input invalid. DC command becomes valid.
 - AC1 : Analog command input valid.
 - When input voltage polarity is + (positive) : CCW direction
 - AC-1: Analog command input valid
 - When input voltage polarity is - (negative) : CW direction

9.3.1. RS-232C Communication Command

- In the velocity control mode, the operation of the Motor can be executed through RS-232C communication command.
- Setting the parameter AC (AC0) makes the DC command valid.

Then input

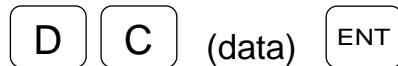

to control the Motor under the proportional speed to the command data value.

- The relation between the command DC data and velocity is shown in Figure 9-12.

Figure 9-12

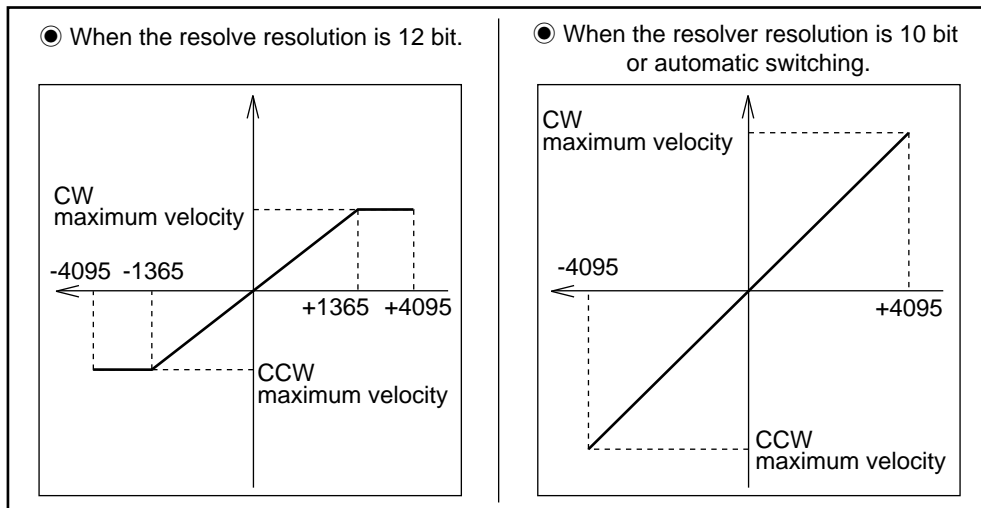

Caution : When the polarity of the position scale is reversed by setting DI parameter, the polarity of DC command is also reversed.

Table 9-12

Motor series	Maximum velocity	
	Resolver resolution: 12 bit	Resolver resolution: 10 bit or automatic switching
YS, JS1, JS2, RS	1 r.p.s.	3 r.p.s.
SS	1.25 r.p.s.	3.75 r.p.s.
AS, BS, JS0	1.5 r.p.s.	4.5 r.p.s.

9.3.2. Analog Velocity Command

- In the velocity control mode operation, the Motor may be controlled directly by inputting analog command.
 - Voltage range of analog command is $\pm 10V$. The offset adjustment may be performed with VR1 pod on the front panel of a Driver Unit.
 - Setting the parameter AC reverses the polarity of analog command voltage.
 - AC1 : Analog voltage + : CCW
 - AC -1 : Analog voltage + : CW
 - The parameter AGV changes the relation between analog voltage and velocity.

Figure 9-13

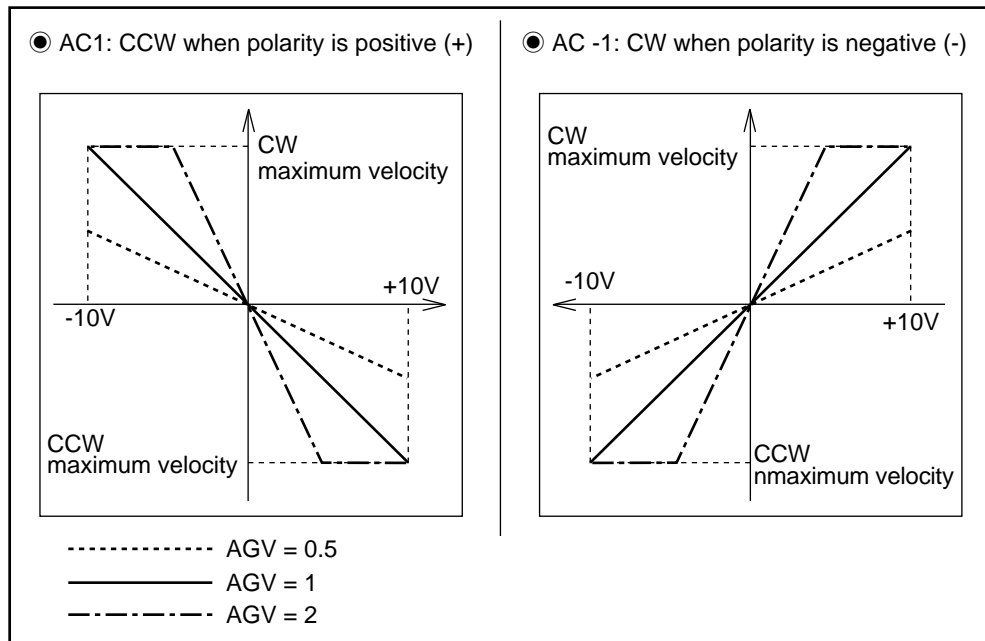
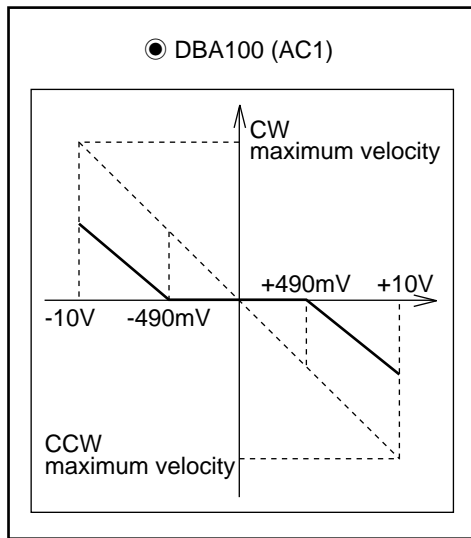

Table 9-13

Motor series	Maximum velocity	
	Resolver resolution: 12 bit	Resolver resolution: 10 bit or automatic switching
YS, JS1, JS2, RS	1 r.p.s.	3 r.p.s.
SS	1.25 r.p.s.	3.75 r.p.s.
AS, BS, JS0	1.5 r.p.s.	4.5 r.p.s.

- The parameter DBA sets the dead band for analog command input.
One unit of data sets $\pm 4.9\text{mV}$ dead band.

Figure 9-14: Example DBA100 (AC1)



9.4. Torque Control Mode Operation

- Torque control mode can be set with the SL parameter.
 - SL1: Torque control mode
 - SL2: Velocity control mode
 - SL3: Position control mode
- Torque control mode is available in the analog command input or RS-232C command input.
- The mode is switched by the parameter AC.
 - AC0 : Analog command input invalid. DC command becomes valid.
 - AC1 : Analog command input valid.
 - When input voltage polarity is + (positive) : CCW direction
 - AC-1: Analog command input valid
 - When input voltage polarity is - (negative) : CW direction

9.4.1. RS-232C Communication Command

- In the torque control mode, the operation of the Motor can be executed through RS-232C communication command.
- Setting the parameter AC (AC0) makes the DC command valid.
Then input

(data)

to control the Motor under the proportional speed to the command data value.

- The relation between the command DC data and torque is shown in Figure 9-15.

Figure 9-15

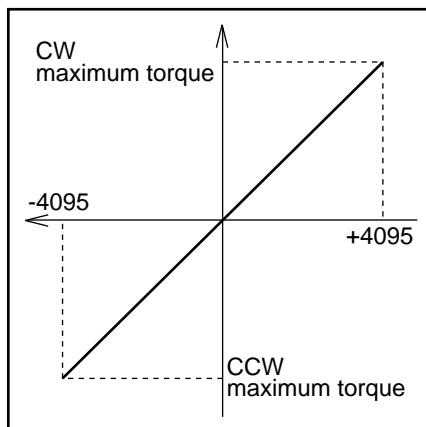

- Torque output varies with the Motor type.

9.4.2. Analog Torque Command

- In the torque control mode operation, the Motor may be controlled directly by inputting analog command.
 - Voltage range of analog command is $\pm 10V$. The offset adjustment may be performed with VR1 pod on the front panel of a Driver Unit.
 - Setting the parameter AC reverses the polarity of analog command voltage.
 - AC1 : Analog voltage + : CCW
 - AC -1 : Analog voltage + : CW
 - The parameter AGT changes the relation between analog voltage and torque.

Figure 9-16

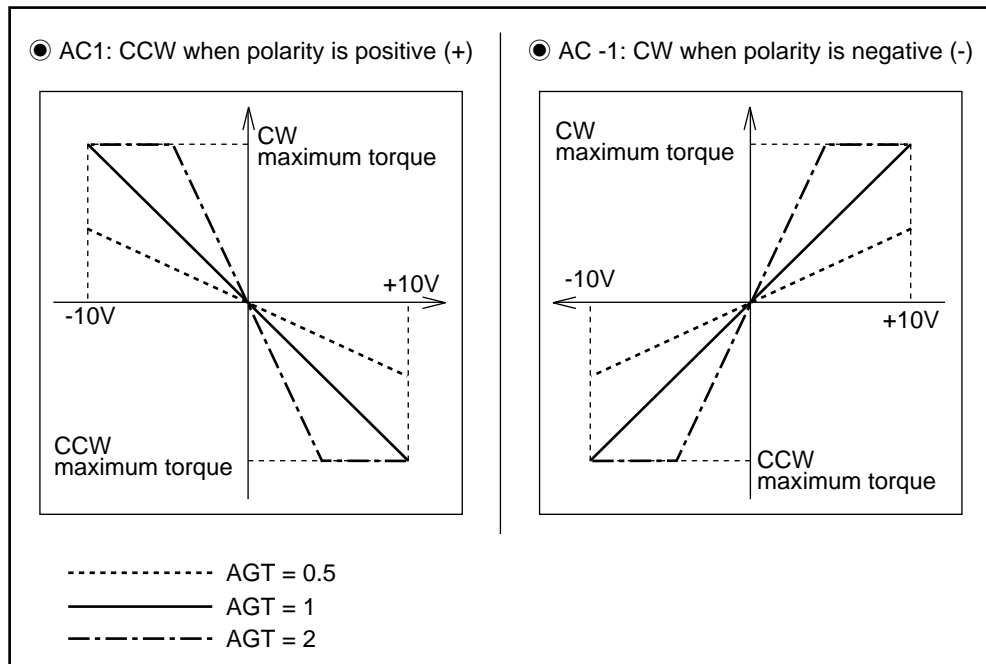

- The parameter DBA sets the dead band for analog command input. One unit of data sets $\pm 4.9mV$ dead band.

Figure 9-17: Example of DBA100 (AC1)

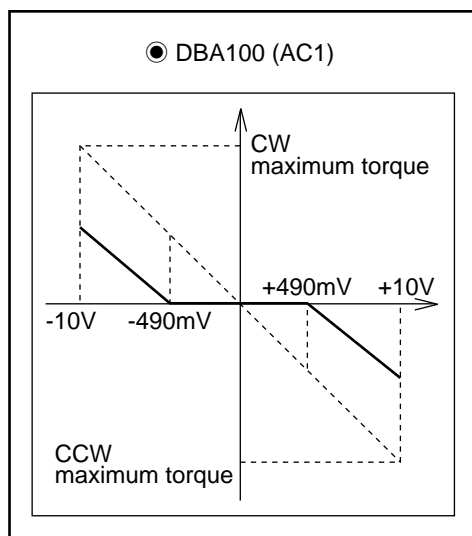

10. Programming

- The Driver Unit can store indexing profiles in its memory. To index along the stored indexing motion profile, external input (CN5 connector signal) is used. This function is called “Programmable Indexer”.
- The program of an indexing motion profile can be done via RS-232C communication. (Handy Terminal FHT11 or a personal computer.) The programming can be input only when the Motor is not indexing.
- The program area is shown in Figure 10-1. There are 64 channels ranging from channel 0 to 64.

Figure 10-1

Channel 0	CH0
Channel 1	CH1
⋮	⋮
Channel 64	CH64

10.1. Commands and Parameters

● Home Return

Command : HS Condition setting : None

- Program Home Return operation.
- Command format : HS seq
seq : sequence code (*, &) Refer to “Sequence Code” in next page.
- The Motor rotates according to the values set by Home Return velocity HV, Home Return acceleration HA, Home Return near-zero velocity HZ, and to the direction set by Home Return direction HD.

Caution : *Direction of Home Return may be reversed using HD parameter.*

- HD0 : CW direction
- HD1 : CCW detection (Shipping set)

*Program example

```
:CH0
HS
```

● Positioning

Command : AD Condition setting : CV
 AR CA
 ID Can be omitted
 IR

- Program the Indexing motion profile.

Table 10-1

Command format	Outline	Option
AD d1 d3 seq	<ul style="list-style-type: none"> ● Absolute indexing, in the units of degree. ● The Motor turns to reach the d1 [$\times 0.01^\circ$] position of position scale. 	Option code d3 /PL: CW direction /MI: CCW direction
AR d1 d3 seq	<ul style="list-style-type: none"> ● Absolute indexing in the units of pulse. ● The Motor turns to reach the d1 [pulse] position of position scale. 	<ul style="list-style-type: none"> ● When d3 is omitted, the Motor turns in the shortest-distance direction to reach the d1 position.
ID d1 d2 seq	<ul style="list-style-type: none"> ● Incremental indexing, in the units of degree. ● The Motor makes a d1 [$\times 0.01^\circ$] turn from the present position. 	Option code d2 /n: (n \leq 99)
IR d1 d2 seq	<ul style="list-style-type: none"> ● Incremental indexing in the units of pulse ● The Motor makes a d1 [pulse] turn from the present position. 	<ul style="list-style-type: none"> ● When d2 is specified, the d1 value is equally divided by n. Single RUN input will make motor rotate by the divided amount. ● When d2 is omitted, the d1 value will not be divided.

- seq stands for the sequence code (*, &), which sets the execution condition of the next channel in the sequence.
- Velocity CV and acceleration CA can be set in the same channel. When CV and CA are omitted, the Motor operates according to the values set by MV and MA, respectively.

*Program example

```

:CH0
IR9000/2
CV1.5
CA5

```

Figure 10-2

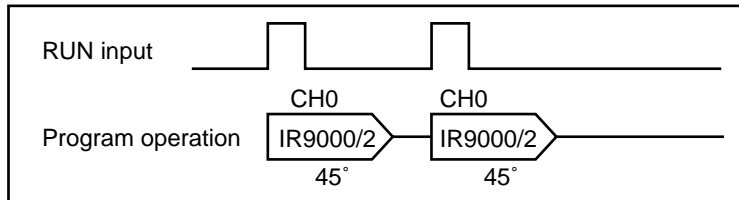

● Jump

Command : JP Condition setting : None

- Unconditional jump command
- Control jumps to the specified channel, and it's program will be executed continuously.
- Command format JPm
m : Jump destination channel No. (default: 0).

*Program example

```

:CH0
IR1000&
:CH1
IR2000&
:CH2
JP0

```

Figure 10-3

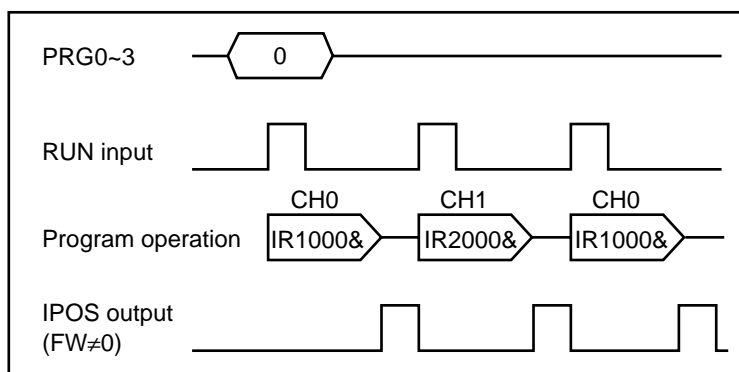

10.2. Program Editing Command

Table 10-3: Program editing command

Editing	Command	Function
Changing Program Settings	CH	<ul style="list-style-type: none"> • Typing C H m ENT declares the channel to be changed. (m: desired channel number) • The display shows the present program and waits for the changes. (The prompt is in “?” state.) • The last input program or data always becomes valid.
Display Program	TC	<ul style="list-style-type: none"> • Typing T C m ENT displays the program in desired channel. (m: desired channel number) • When checking the program in all channels, type T C / A L ENT. • Type SP key to scroll to next channel.
Deleting Program	CC	<ul style="list-style-type: none"> • Typing T C m ENT deletes the program in the desired channel. (m: desired channel number)

10.3. Inputting a Program

● Programming

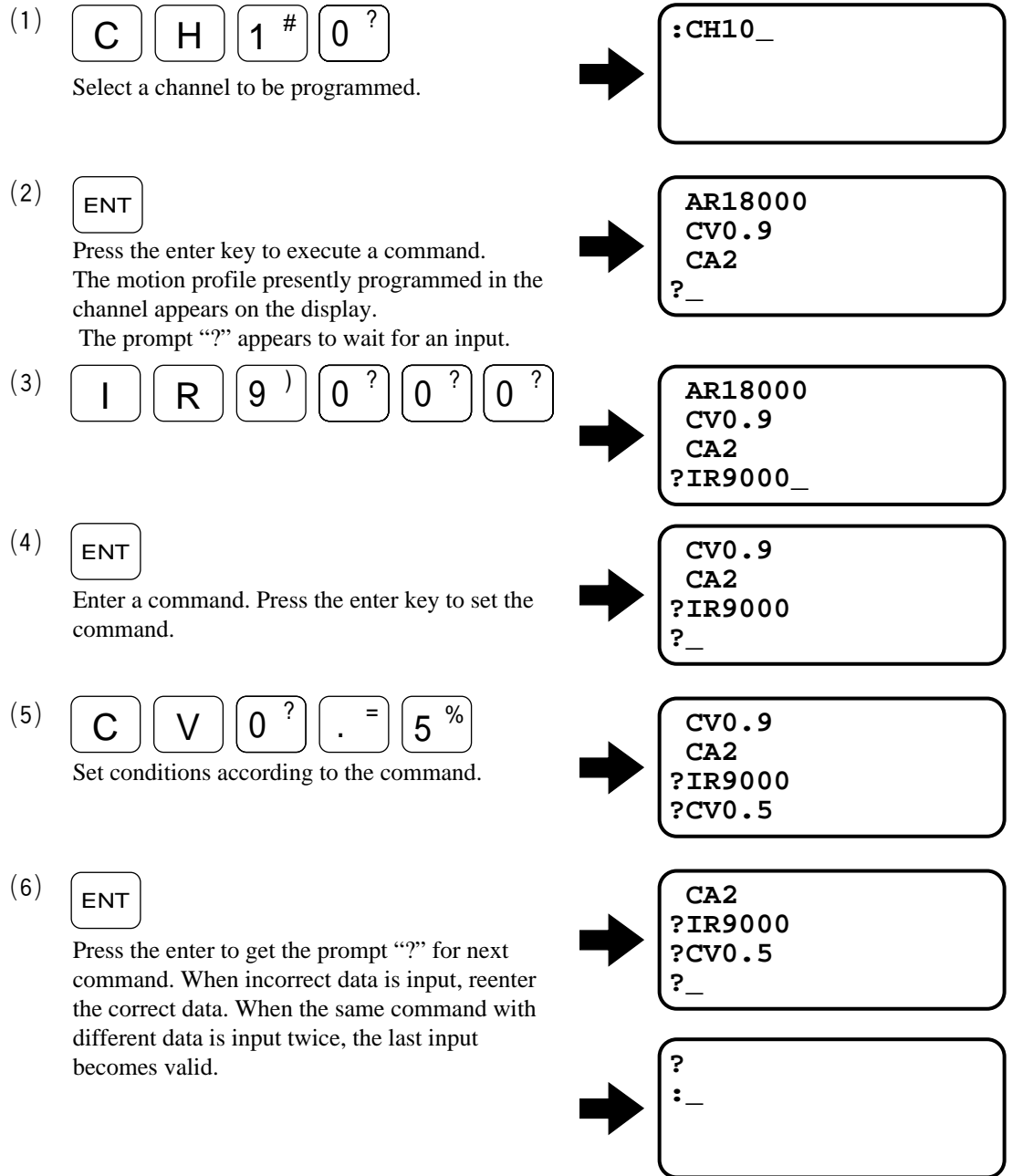

● Reading channel program

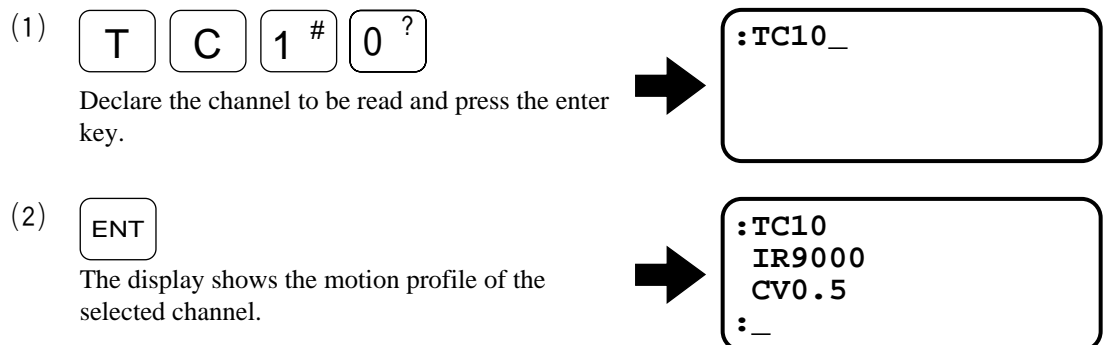

● **Deleting the program**

(1)

Declare the channel whose data is to be deleted.



:CC10_

(2)

Pressing the enter key deletes the data programmed in the channel.



:CC10
:_

10.4. Sample Program

- Write the following motion profile in Channel 5.

- Travel angle 30.00 degrees in the CCW direction
- Acceleration CA: 5 [r.p.s/s]
- Velocity CV: 0.5 [r.p.s]

- (1) Check that the “:” prompt is displayed on the screen.

:_

- (2) **C** **H** **5 %**

:CH5_

- (3) **ENT**

After pressing the ENT key, the data presently programmed in Channel 5 will be shown on the display.

AD27000&
CV1.00
CA20.00
?_

- (4) **I** **D** **- +**
3 < **0 ?** **0 ?** **0 ?**

AD27000&
CV1.00
CA20.00
?ID-3000_

- (5) **ENT**

Press the ENT key to input value, and the “?” prompt appears again.

CV1.00
CA20.00
?ID-3000
?_

- (6) **C** **A** **5 %**

CV1.00
CA20.00
?ID-3000
?CA5_

- (7) **ENT**

Press the ENT key to input value, and the “?” prompt appears again.

CA20.00
?ID-3000
?CA5
?_

- (8) **C** **V** **0 ?** **. =** **5 %**

CA20.00
?ID-3000
?CA5
?CV0.5_

- (9) **ENT**

Press the ENT key to input value, and the “?” prompt appears again.

?ID-3000
?CA5
?CV0.5
?_

- (10) **ENT**

Press the ENT key again to escape programming. This completes programming.

?CA5
?CV0.5
?
:_

11. Command and Parameter

- Connect Handy Terminal FHT11 to CN1 connector of the Driver Unit, then turn the power on. The system is in normal state if “NSK MEGA---” message is returned.
- Refer to “6. Handy Terminal Communication” for details.

11.1. List of Command and Parameter

- Tables 11-1, 11-2 and 11-3 are the lists of commands and parameters.
- Some parameters shown in the tables must be changed to unique values according to actual condition from the shipping set.
- Parameters parenthesized are properly set at the factory. If Changing is necessary, contact your local NSK representative.
 - * : (Current Setting) Set unique value to your application. We recommend to write down the set value for your future reference. You may need to refer to them when changing the operating conditions or readjusting the system. For your convenience, a parameter and program setting list is provided in Appendix 6 of this manual.
 - ** : Setting differs with the Motor type and size.

Table 11-1: YS, JS1, JS2 and RS Motor standard setting

Parameter	Name	Password	Shipping set	Data range	Current setting *
PG	Position gain	×	0.1	0.010 ~ 1.000	
VG	Velocity gain	×	1.0	0.10 ~ 255.0	
VI	Velocity integrator frequency	×	1.0	0.10 ~ 63.00	
VM	Velocity integrator mode	○	1	0, 1	
LG	Low-velocity gain	×	50	10 ~ 100	
TL	Torque limit	○	100	0 ~ 100	
FO	Low-pass filter off velocity	×	0	0, 0.001 ~ 3.000	
FP	Low-pass filter, Primary	×	0	0, 10 ~ 500	
FS	Low-pass filter, Secondary	×	0	0, 10 ~ 500	
NP	Notch filter, Primary	×	0	0, 10 ~ 500	
DBP	Position loop dead band	○	0	0, 1 ~ 4095	
DBA	Analog command input dead band	○	0	0, 1 ~ 2047	
ILV	Integration limit	○	100	0 ~ 100	
FF	Feed forward gain	○	0	0 ~ 1.0000	
FC	Friction compensation	○	0	0 ~ 2047	
CO	Position error counter over limit	×	50000	0, 1 ~ 99 999 999	
IN	In-position	×	100	0 ~ 99 999 999	
IS	In-position stability timer	×	0	0, 0.3 ~ 100	
FW	FIN width	×	1	0, 0.3 ~ 100	
CR	Circular resolution	○	×1	×1, ×2, ×4, 360000, 36000, 3600	
PC	Pulse command	○	0	0 ~ 4	
RR	Resolver resolution	○	-1	-1, 0, 1	
FD	Feedback direction mode	○	0	0, 1	
FZ	Feedback phase Z configuration	○	0	0, 1	
FR	Feedback signal resolution	○	0	0, 1	
PS	Position scale	○	1	0, 1, 2 ~ 99	
DI	Direction inversion	○	0	0, 1	
OTP	Overtravel limit switch position	○	0	-99999999 ~ 99999999	
OTM	Overtravel limit switch position	○	0	-99999999 ~ 99999999	
MV	Move velocity	×	1	0.01 ~ 3	
MA	Move acceleration	×	1	0.01 ~ 40	
JV	Jog velocity	×	0.10	0.01 ~ 3	
JA	Jog acceleration	×	1	0.01 ~ 40	
HV	Home Return velocity	×	0.2	0.01 ~ 3	
HA	Home Return acceleration	×	1	0.01 ~ 40	
HZ	Home Return near-zero velocity	×	0.01	0.01 ~ 0.2	
OS	Origin setting mode	○	4	1, 3, 4, 5	
HD	Home Return direction	○	1	0, 1	
HO	Home offset	○	0	-610 304 ~ 610 304	
(PA)	Phase adjust	○	700	-	
(OL)	Overload limit	○	**	**	
(RC)	Rated current	○	**	**	
LR	Low torque ripple	○	0	0, 1	
AB	I/O polarity	○	X0X0XX00	0, 1, X	
NW	Neglect width	○	2	0 ~ 4	
MM	Multi-line Mode	○	1	0, 1	
BM	Backspace mode	○	1	0, 1	
CM	Communication mode	○	0	0, 1	
AN	Axis number	○	0	0 ~ 15	
WM	Write mode to EEPROM	○	0	0, 1	
LO	Load inertia	×	0	0.000 ~ 50.000	
SG	Servo gain	×	0	0 ~ 30	
(MT)	Factory use only	○	-	-	
(RI)	Factory use only	○	-	-	
(ZP)	Factory use only	○	1.00	-	
(ZV)	Factory use only	○	1.4	-	
SL	Set serve loop	○	3	1, 2, 3	
AC	Analog command mode	○	1	-1, 0, 1	
AGV	Velocity command gain	○	1	0.10 ~ 2.00	
AGT	Torque command gain	○	1	0.10 ~ 2.00	

Table 11-2: SS Motor standard setting

Parameter	Name	Password	Shipping set	Data range	Current setting *
PG	Position gain	×	0.1	0.010 ~ 1.000	
VG	Velocity gain	×	1.0	0.10 ~ 255.0	
VI	Velocity integrator frequency	×	1.0	0.10 ~ 63.00	
VM	Velocity integrator mode	○	1	0, 1	
LG	Low-velocity gain	×	50	10 ~ 100	
TL	Torque limit	○	100	0 ~ 100	
FO	Low-pass filter off velocity	×	0	0, 0.001 ~ 3.000	
FP	Low-pass filter, Primary	×	0	0, 10 ~ 500	
FS	Low-pass filter, Secondary	×	0	0, 10 ~ 500	
NP	Notch filter, Primary	×	0	0, 10 ~ 500	
DBP	Position loop dead band	○	0	0, 1 ~ 4095	
DBA	Analog command input dead band	○	0	0, 1 ~ 2047	
ILV	Integration limit	○	100	0 ~ 100	
FF	Feed forward gain	○	0	0 ~ 1.0000	
FC	Friction compensation	○	0	0 ~ 2047	
CO	Position error counter over limit	×	50000	0, 1 ~ 99 999 999	
IN	In-position	×	100	0 ~ 99 999 999	
IS	In-position stability timer	×	0	0, 0.3 ~ 100	
FW	FIN width	×	1	0, 0.3 ~ 100	
CR	Circular resolution	○	×1	×1, ×2, ×4, 360000, 36000, 3600	
PC	Pulse command	○	0	0 ~ 4	
RR	Resolver resolution	○	-1	-1, 0, 1	
FD	Feedback direction mode	○	0	0, 1	
FZ	Feedback phase Z configuration	○	0	0, 1	
FR	Feedback signal resolution	○	0	0, 1	
PS	Position scale	○	1	0, 1, 2 ~ 99	
DI	Direction inversion	○	0	0, 1	
OTP	Overtravel limit switch position	○	0	-99999999 ~ 99999999	
OTM	Overtravel limit switch position	○	0	-99999999 ~ 99999999	
MV	Move velocity	×	1	0.01 ~ 3.75	
MA	Move acceleration	×	1	0.01 ~ 50	
JV	Jog velocity	×	0.10	0.01 ~ 3.75	
JA	Jog acceleration	×	1	0.01 ~ 50	
HV	Home Return velocity	×	0.2	0.01 ~ 3.75	
HA	Home Return acceleration	×	1	0.01 ~ 50	
HZ	Home Return near-zero velocity	×	0.01	0.01 ~ 0.2	
OS	Origin setting mode	○	4	1, 3, 4, 5	
HD	Home Return direction	○	1	0, 1	
HO	Home offset	○	0	-487 424 ~ 487 424	
(PA)	Phase adjust	○	700	-	
(OL)	Overload limit	○	**	**	
(RC)	Rated current	○	**	**	
LR	Low torque ripple	○	0	0, 1	
AB	I/O polarity	○	X0X0XX00	0, 1, X	
NW	Neglect width	○	2	0 ~ 4	
MM	Multi-line Mode	○	1	0, 1	
BM	Backspace mode	○	1	0, 1	
CM	Communication mode	○	0	0, 1	
AN	Axis number	○	0	0 ~ 15	
WM	Write mode to EEPROM	○	0	0, 1	
LO	Load inertia	×	0	0.000 ~ 50.000	
SG	Servo gain	×	0	0 ~ 30	
(MT)	Factory use only	○	-	-	
(RI)	Factory use only	○	-	-	
(ZP)	Factory use only	○	1.00	-	
(ZV)	Factory use only	○	1.4	-	
SL	Set serve loop	○	3	1, 2, 3	
AC	Analog command mode	○	1	-1, 0, 1	
AGV	Velocity command gain	○	1	0.10 ~ 2.00	
AGT	Torque command gain	○	1	0.10 ~ 2.00	

Table 11-3: AS, BS and JS0 Motor standard setting

Parameter	Name	Password	Shipping set	Data range	Current setting *
PG	Position gain	×	0.1	0.010 ~ 1.000	
VG	Velocity gain	×	1.0	0.10 ~ 255.0	
VI	Velocity integrator frequency	×	1.0	0.10 ~ 63.00	
VM	Velocity integrator mode	○	1	0, 1	
LG	Low-velocity gain	×	50	10 ~ 100	
TL	Torque limit	○	100	0 ~ 100	
FO	Low-pass filter off velocity	×	0	0, 0.001 ~ 3.000	
FP	Low-pass filter, Primary	×	0	0, 10 ~ 500	
FS	Low-pass filter, Secondary	×	0	0, 10 ~ 500	
NP	Notch filter, Primary	×	0	0, 10 ~ 500	
DBP	Position loop dead band	○	0	0, 1 ~ 4095	
DBA	Analog command input dead band	○	0	0, 1 ~ 2047	
ILV	Integration limit	○	100	0 ~ 100	
FF	Feed forward gain	○	0	0 ~ 1.0000	
FC	Friction compensation	○	0	0 ~ 2047	
CO	Position error counter over limit	×	50000	0, 1 ~ 99 999 999	
IN	In-position	×	100	0 ~ 99 999 999	
IS	In-position stability timer	×	0	0, 0.3 ~ 100	
FW	FIN width	×	1	0, 0.3 ~ 100	
CR	Circular resolution	○	×1	×1, ×2, ×4, 360000, 36000, 3600	
PC	Pulse command	○	0	0 ~ 4	
RR	Resolver resolution	○	-1	-1, 0, 1	
FD	Feedback direction mode	○	0	0, 1	
FZ	Feedback phase Z configuration	○	0	0, 1	
FR	Feedback signal resolution	○	0	0, 1	
PS	Position scale	○	1	0, 1, 2 ~ 99	
DI	Direction inversion	○	0	0, 1	
OTP	Overtravel limit switch position	○	0	-99999999 ~ 99999999	
OTM	Overtravel limit switch position	○	0	-99999999 ~ 99999999	
MV	Move velocity	×	1	0.01 ~ 4.5	
MA	Move acceleration	×	1	0.01 ~ 60	
JV	Jog velocity	×	0.10	0.01 ~ 4.5	
JA	Jog acceleration	×	1	0.01 ~ 60	
HV	Home Return velocity	×	0.2	0.01 ~ 4.5	
HA	Home Return acceleration	×	1	0.01 ~ 60	
HZ	Home Return near-zero velocity	×	0.01	0.01 ~ 0.2	
OS	Origin setting mode	○	4	1, 3, 4, 5	
HD	Home Return direction	○	1	0, 1	
HO	Home offset	○	0	-405 504 ~ 405 504	
(PA)	Phase adjust	○	700	-	
(OL)	Overload limit	○	**	**	
(RC)	Rated current	○	**	**	
LR	Low torque ripple	○	0	0, 1	
AB	I/O polarity	○	X0X0XX00	0, 1, X	
NW	Neglect width	○	2	0 ~ 4	
MM	Multi-line Mode	○	1	0, 1	
BM	Backspace mode	○	1	0, 1	
CM	Communication mode	○	0	0, 1	
AN	Axis number	○	0	0 ~ 15	
WM	Write mode to EEPROM	○	0	0, 1	
LO	Load inertia	×	0	0.000 ~ 50.000	
SG	Servo gain	×	0	0 ~ 30	
(MT)	Factory use only	○	-	-	
(RI)	Factory use only	○	-	-	
(ZP)	Factory use only	○	1.00	-	
(ZV)	Factory use only	○	1.4	-	
SL	Set serve loop	○	3	1, 2, 3	
AC	Analog command mode	○	1	-1, 0, 1	
AGV	Velocity command gain	○	1	0.10 ~ 2.00	
AGT	Torque command gain	○	1	0.10 ~ 2.00	

11.2. Glossary

- This section provides description and specifications of commands and parameters.
- “Shipping set” denotes a value which is set at the factory before shipment.
- “Default” denotes a value which is adopted by entering a command and parameter with no data. For example, if you input “DC” only, it will be recognized and executed as “DC0”, because the default set of the “DC” command data is 0. If the command does not have a default set, then you cannot execute the command without data.
- The password must be entered before inputting a command marked with ★. Refer to “6.2.1. Password” for more details.

★ **AB** : I/O polarity

Format	: AB n1 n2 n3 n4 n5 n6 n7 n8
Data	: nn=0 A contact (Normally open) nn=1 B contact (Normally closed) nn=X ○ At the time of input: The port set to X does not change polarity. ○ At the time of read-out: For the port which is shown as “X”, the polarity can not be change. (A contact is fixed.)
Shipping set	: ABX0X0XX00 (all A contacts)
Default	: Not omissible (input all 8 digits)

- Set the polarity of input command port.
- The ports of which the polarity can be changed are EMDT, HLS, OTP and OTM. The other ports are fixed to A contact.
- Set “X” for the port of which polarity can not be changed. If “0” or “1” is input, the display shows “?” indicating the fault input.
- Polarity setting can be read by “TS” or “?AB” command.
- The table below shows the data and port.

Data digit	n1	n2	n3	n4	n5	n6	n7	n8
CN2 pin No.	25	12	24	11	23	10	22	9
Signal name	SVON	EMST	IOFF	HLS	HOS	CLR	OTM	OTP

★ AC : Analog Command Mode

Format : AC data
 Data range : -1, 0, 1
 Shipping set : 1
 Default : 0

- Set the validity (valid/invalid) and polarity of the analog command input.
 - AC0 : Analog command input invalid. DC command is valid.
 - AC1 : Analog command input valid. Voltage + : CCW direction
 - AC-1 : Analog command input valid. Voltage +: CW direction
- When the parameter DI is set to reverse the polarity, above polarity is reversed.
- Setting of “AC” command can be read by “TS” or “?AC” command.

AD: Absolute Positioning, Degree

Format : AD data1/data2
 Data1 : Differs with parameter “PS” [0.01°]
 Default data1 : 0
 Data2 : PL, MI
 Default data2 : direction in which the move distance is shortest

- “data1” indicates the position of the destination. This position complies with user absolute position scale (which may be read out by issuing TP5). Refer to “8.2.1. Position Scale” for more details.
- “data1” range differs with “PS” setting.

	Data range (data1)
PS0	-99 999 999 ~ +99 999 999
PSn	0 ~ (36000 × n) -1

n: n=1-99, Shipping set: n=1

- “data2” indicates the rotational direction. When the parameter “PS” is set to “0” (PS0), “data2” setting is invalid.
 - ① PL: CW direction [When the parameter “DI” is set to “1” (DI1), the direction is reversed. (CCW)]
 - ② DI: CCW direction [When the parameter “DI” is set to “1” (DI1), the direction is reversed. (CW)]
 - ③ If the “data2” is omitted, the Motor moves to the direction in which the shortest distance to the destination. (If the present position and the destination is same, the movement is “0”.)
- This command has two functions, which depend on the usage.
 - ① If it is entered in the normal standby condition (the prompt is “:”) , it serves as a positioning command.
 - ② If it is entered under the condition where a channel to be programmed is selected with a CH command, the Driver Unit outputs “?,” and the system waits for a command to be entered, it specifies the rotational amount data to the channel.

★ AG : Analog Command Gain

Format	: AGV data AGT data
Data range	: 0.10 ~ 2.00
Shipping set	: 1 (both AGV and AGT)
Default	: Not omissible

- This command sets the analog command gain in the velocity and torque control mode.
AGV: Analog command gain in velocity control mode
AGT: Analog command gain in torque control mode
- Actual gain value is in proportion to the velocity or torque command.
 - Example
When AGV0.5:
Actual velocity command = Velocity command input × 0.5
- “TS” or “?AG” command reports the current setting.

★ AN : Axis Number

Format	: AN data
Data range	: 0 ~ 15
Shipping set	: 0
Default	: 0

- Sets the axis number in the daisy chain communication mode.
- “TS” command or “?AN” command reports the current setting.
- Refer to “8.3.3. Daisy Chain Communication”.

AR : Absolute Positioning, Resolver

Format : AR data1/data2
Data1 : Differs with the parameter "PS" setting.
Default data1 : 0
Data2 : PL, MI
Default data2 : Direction in which the move distance is shortest

- "data1" indicates the position of the destination. This position complies with user absolute position scale (which may be read out by issuing "TP2"). Refer to "8.2.1. Position Scale".
- Format of "data1" differs with the parameter "PS" setting and the Motor series.

	Data format (data1)		
	YS, JS1, JS2, RS	SS	AS, BS, JS0
PS0	-99 999 999 ~ +99 999 999	-99 999 999 ~ +99 999 999	-99 999 999 ~ +99 999 999
PSn	0 ~ (614400 × n) -1	0 ~ (491520 × n) -1	0 ~ (409600 × n) -1

n=1~99, Shipping set: n=1

- "data 2" indicates the rotational direction. When PS parameter is set to "0 (zero)", the "data 2" is invalid.
 - (1) PL: CW direction (When the parameter "DI1" is set, the direction is CCW.)
 - (2) MI: CCW direction (When the parameter "DI1" is set, the direction is CW.)
 - (3) If the "data 2" is omitted, the Motor rotates to the shortest direction to the destination. (If the current position is the same as the destination, the Motor does not rotate.)
- This command has two functions, which depend on the usage.
 - ① If it is entered under the condition where a channel to be programmed is selected with a CH command, the Driver Unit outputs "?," and the system waits for a command to be entered, it specifies the rotational amount of the Programmable Indexer channel.
 - ② If it is entered in the normal standby condition, it serves as a positioning command.

AS : Ask Daisy Chain Status

Format : AS

- When communication in daisy chain style, AS reads out the status of each axis connected to Driver Units.
- The "AS" command is executed automatically when power is turned on in the daisy chain communication mode.
- After the "AS" command is executed, the Driver Unit of axis 0 is always selected.

AT : Automatic Tuning

Format : AT

- Execute "automatic tuning" to set proper servo parameters and acceleration.

AX : Axis Select

Format	: AX data
Data	: 0 ~ 15
Shipping set	: 0
Default	: 0

- When communicating in daisy chain, AX selects the one of the Driver Unit. Selected Driver Unit sends a confirmation signal back to the RS-232C terminal.
- Confirmation message “ACC. AXn ” (n = selected Driver Unit number). The Driver Unit of axis 0 is always selected when power is turned on.
- Report command “TS” or “?AX” is valid when daisy chain communication is active.
- If “AX” is input when daisy chain is not active, an error message will be given back.
- Also if “TS” or “?AX” command is input when daisy chain is not active, an error message will be given.

Caution : Do not select any unit that is not connected. Otherwise, operation may hang up. To return to the normal state, press the **BS** key first, then the number of a connected Driver Unit.

★ **AZ : Absolute Zero Position Set**

Format	: AZ
--------	------

- If the “AZ” command is executed with the Motor stationary at any position, the position is adopted as user absolute Home position.

★ **BM : Backspace Mode**

Format	: BM data
Data	: 0 or 1
Shipping set	: 1
Default	: 0

- BM changes the function of the **BS** key.
 - BM0: A press of the **BS** key cancels an entered character string.
 - BM1: A press of the **BS** key deletes a character.
- TS or “?BM” command reports the current setting.

CA : Channel Acceleration

Format	: CA data
Data	: Motor series
	YS, JS1, JS2, RS : 0, 0.01~40.00 [r.p.s/s]
	SS : 0, 0.01~50.00 [r.p.s/s]
	AS, BS, JS0 : 0, 0.01~60.00 [r.p.s/s]
Default	: 0

- This command is used to specify the rotational acceleration of a given channel of the internal program.
- The “CA” command may be input under the condition where a channel to be programmed is selected with a “CH” command, the Driver Unit outputs “?”, and the system waits for a command to be entered. If it is entered in the normal stand-by state, an error occurs.
- If no setting is made in a channel (or 0 is specified), the rotational acceleration specified with an “MA” command is valid.
- “TC” command reports the current setting.
 - If “0 (zero)” is set, no response is displayed.

CC : Clear Channel

Format	: CC data1
Data1	: 0 ~ 15
Data1 default	: 0

- CC deletes the program data of a channel specified in “data.”

CH : Channel Select

Format	: CH data
Data1	: 0 ~ 15
Data1 default	: 0

- This command is to select the channel to be programmed.
- The input program can be read with “TC” command.

Caution : Input program when the system is servo-off state.

CL : Clear Alarm

Format	: CL
--------	------

- “CL” command clears “excess error”, “software thermal” and “program error” alarms. (Other alarms can not be cleared with “CL” command.)

★ **CM** : **Communication Mode**

Format	: CM data
Data	: 0 or 1
Shipping set	: 0
Default	: 0

- CM Selects the RS-232C communication mode.
CM0: Standard
CM1: Daisy chain communication
- The CM parameter set at the time of power-on is valid.
- To change the communication mode, change the CM parameter, turn off the power, then turn it on again.
- “TS” or “?CM” command reports the current setting.

CO : **Position Error Counter Over Limit**

Format	: CO data
Data	: 0 or 1 ~ 99999999 [pulse]
Shipping set	: 50000
Default	: 0

- CO Sets the position error counter value at which the excess position error alarm is to be detected.
- When the position error exceeds the set value, the Driver Unit outputs the excess position error alarm and opens the DRDY output circuit.
- If 0 is specified, the excess position error alarm detection is invalidated (i.e., no alarm function).
- “TS” or “?CO” command reports the current setting.

★ **CR** : **Circular Resolution**

Format	: CR data
Data	: X1, X2, X4, 360000, 36000, 3600
Shipping set	: X1
Default	: Not omissible

- Use to specify the pulse train input resolution.
- For the details, refer to “9.2.3. Pulse Train Command Operation”.
- The resolution changes immediately after CR data is specified.
- “TS” or “?CR” command reports the current setting.

CV : Channel Velocity

Format	: CV data
Data	: Motor series
	YS, JS1, JS2, RS : 0, 0.01~3.00 [r.p.s]
	SS : 0, 0.01~3.75 [r.p.s]
	AS, BS, JS0 : 0, 0.01~4.50 [r.p.s]
Default	: 0

- This command is used to specify the rotational velocity of each channel of the Programmable Indexer.
- The “CV” command may be input under the condition where a channel to be programmed is selected with a “CH” command, the Driver Unit outputs “?,” and the system waits for a command to be entered. If it is entered in the normal stand-by state, an error occurs. (normal stand-by state: when the colon “:” is displayed while waiting for input.)
- If no setting is made in a channel (or 0 is specified), the rotational velocity specified with an “MV” command is valid
- “TC” command reports the current setting.
 - If “0 (zero)” is set, no response is displayed.

★ DB : Dead Band

Format	: DBA data
	DBP Data
Data DBA	: 0, 1 ~ 2047
Data DBP	: 0. 1 ~ 4095
Shipping set	: 0 (for both DBA and DBP)
Default	: 0

- Sets a dead band for the position loop and analog command input.
 - DBP: Position loop dead band
 - DBA: Analog command input dead band
- “TS” or “?DB” command reports current setting.
- For the details, refer to “8.2.5. Dead Band Setting : DBP”.
- For the details of DBA, refer to “9.3.2. Analog Velocity Command” or “9.4.2. Analog Torque Command”.
- For the details, refer to “8.2.5. Dead Band Setting : DBP”.
- For the details of DBA, refer to “9.3.2. Analog Velocity Command” or “9.4.2. Analog Torque Command”.

DC : Digital RS-232C Command

Format	: DC data
Data	: -4095 ~ 4095 (data polarity in + value: CW direction)
Default	: 0

- This command is to directly input the operation command through RS-232C communication interface in velocity or torque control mode.
However, the use of this command is limited to an ordinal operation or a testing operation of the Motor due to sluggish response.
- If “DC” command is input when an analog command (“AC”π command) is valid, “DC INHIBITED” message is given and the command is invalidated.
- The data of this command is cleared to “0” in following state.
 - ① Servo off
 - ② Emergency stop
 - ③ Overtravel limit
 - ④ Control mode selection
 - ⑤ Analog command is valid.

Caution : When the coordinate polarity is reversed by the parameter DI, data polarity of DC command is also reversed.

★ **DI : Direction Inversion**

Format	: DI data
Data	: 0 or 1
Shipping set	: 0
Default	: 0

- Switches the position scale coordinate counting direction.
- For the details, refer to “8.2.1. Position Scale”.

★ **FC : Friction Compensation**

Format	: FC data
Data	: 0 ~ 2047
Shipping set	: 0
Default	: 0

- “FC” is used to specify a compensation value to cancel rotational static friction of the Motor.
- If 0 is specified in “data”, the function is deactivated.
- Parameter FC can be obtained with the formula shown below.

$$\text{FC "data"} = 2047 \times \frac{\text{Static friction torque}}{\text{Motor maximum torque}}$$

- The setting can be read with “TS” or “?FC” command.

★ **FD : Feed Back Direction Mode**

Format : FD data
Data : 0, 1
Shipping set : 0
Default : 0

- Reverses the output timing between ϕA and ϕB of the position feedback signal.
FD0: Standard; ϕA signal is always ahead of ϕB signal.
FD1: Reverse; ϕB signal is always ahead of ϕA signal.
- “TS” or “?FD” command reports the current setting.

★ **FF : Feed Forward Gain**

Format : FF data
Data : 0.0000 ~ 1.0000
Shipping set : 0
Default : 0

- FF sets the feed forward compensation gain.
- Setting 0 cancels the feed forward compensation function.
- “TS” or “?FF” command reports the current setting.

★ **FO : Low-pass Filter OFF Velocity**

Format : FO data
Data : Motor series
YS, JS1, JS2, RS : 0, 0.01~3.00 [r.p.s]
SS : 0, 0.01~3.75 [r.p.s]
AS, BS, JS0 : 0, 0.01~4.50 [r.p.s]
Shipping set : 0
Default : 0

- Sets the low pass filters (parameter FP and FS), depending upon velocity.
- FO data sets the velocity threshold which turns ON and OFF the low pass filters.

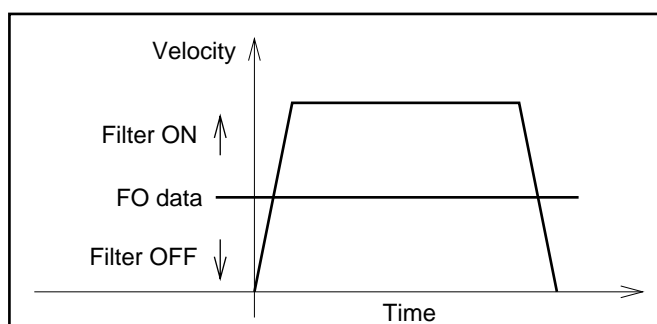

- When this function is set, it is possible to lower the resonance noise level without affecting on the settling time.
- When “FO” is set to 0, the function is invalid. (The low-pass filters are always active.)

FP : Low-pass Filter, Primary

Format	: FP data
Data	: 0, 10 ~ 500 [Hz] or /AJ (Adjusting mode)
Shipping set	: 0
Default	: 0

- FP sets the frequency of the primary low-pass filter of the velocity loop.
- When 0 is input, the velocity-loop primary low-pass filter is set to “off”. At this time, [PRI.LPF OFF] appears on the display.
- When data other than 0 (i.e, 10 ~ 500) is input, the frequency specified by the data is set.
- The set value can be read by the “TS” command and “?FP”.
- Inputting FP/AJ can set to adjusting mode.

★ **FR : Feed Back Signal Resolution**

Format	: FR data
Data	: 0 or 1
Shipping set	: 0
Default	: 0

- Sets the resolution specification of the position feedback signal ϕA and ϕB .
FR0: 10-bit resolution specification
FR1: 12-bit resolution specification
- For more details, refer to “3.2.3. Functional Specification”.
- Set FR0 when the resolver resolution is set to 10-bit or automatic resolution switching by the RR parameter. If FR1 is set, ϕA and ϕB will not be output.
- Both FR0 and FR1 can be selected when the resolver resolution is set to 12-bit specification by the RR parameter.
- “TS” or “?FR” command reports the current setting.

FS : Low-pass Filter, Secondary

Format	: FS data
Data	: 0, 10 ~ 500 [Hz] or /AJ (Adjusting mode)
Shipping set	: 0
Default	: 0

- Sets the frequency of the secondary low-pass filter of the velocity loop.
- When 0 is input, the velocity-loop secondary low-pass filter is set to “off”. At this time, [SEC.LPF OFF] appears on the display.
- When data other than 0 (i.e, 10~500) is input, the frequency specified by the data is set.
- The set value can be read by the “TS” command and “?FS”.
- Inputting FS/AJ can set to adjusting mode.

FW : FIN Width

Format	: FW data
Data	: 0 or 0.3 ~ 100 [0.1 second]
Shipping set	: 1
Default	: 0

- Sets the width (length) of IPOS output. Unit is 0.1 sec.
- If it is set to FW1, the time length of the IPOS output will be 0.1 sec.
- If it is set to FW0, IPOS output is in standard state and always closed when the position error counter value is less than the “IN” setting.
- When it is set to FW0.3 ~ FW100, IPOS output is closed for the moment as set when the position error counter value is less than the “IN” value.
- Refer to “8.1.8. In-Position Output” for the output timing.
- “TS” or “?FW” command reports the current setting.
- Set FW0 when the system is performing the pulse train command operation.

★ FZ : Feedback Phase Z Configuration

Format	: FZ data
Data	: 0 or 1
Shipping set	: 0
Default	: 0

- FZ selects the output type of the position feedback signal CHZ (CN2 output).
FZ0: Outputs the ϕ Z signal from CHZ.
FZ1: Outputs MSB of the digital position signal from CHZ.
- Refer to “8.1.9. Position Feedback Signal” for the output timing of the ϕ Z signal or MSB.
- “TS” or “?FZ” command reports the current setting.

HA : Home Return Acceleration

Format	: HA data
Data	: Motor series
	YS, JS1, JS2, RS : 0, 0.01~40 [r.p.s/s]
	SS : 0, 0.01~50 [r.p.s/s]
	AS, BS, JS0 : 0, 0.01~60 [r.p.s/s]
Shipping set	: 1.00 [r.p.s/s]
Default	: Not omissible

- Sets Home Return acceleration.
- “TS” or “?HA” command reports the current setting.

★ HD : Home Return Direction

Format : HD data
Data : 0 or 1
Shipping set : 1
Default : 0

- HD0: Home Return in the CW direction
- HD1: Home Return in the CCW direction

★ HO : Home Offset

Format : HO data
Data : Motor series
YS, JS1, JS2, RS : -610304 ~ 610304 (pulse)
SS : -487424 ~ 487424 (pulse)
AS, BS, JS0 : -405504 ~ 405504 (pulse)
Shipping set : 0
Default : 0

- Specifies an offset value from the point where the RDC position data reaches 0 for the first time, after the Home position limit switch input (HLS on CN2) goes inactive, to the point where the Motor stops.
- “TS” or “?HO” command reports the current setting.

HS : Home Return Start

Format : HS

- Starts Home Return.
- Input HS/LS to adjust the installation position of the home limit switch (sensor).
- For more details, refer to “9.2.1.2. Adjusting Home Limit Switch and Home Offset Value”.

HV : Home Return Velocity

Format : HV data
Data : Motor series
YS, JS1, JS2, RS : 0.01~3.00 [r.p.s]
SS : 0.01~3.75 [r.p.s]
AS, BS, JS0 : 0.01~4.50 [r.p.s]
Shipping set : 0.2
Default : 0

- Sets Home Return velocity.
- “TS” or “?HV” command reports the current setting.

***HZ* : Home Return Near-Zero Velocity**

Format	: HZ data
Data	: 0.01 ~ 0.20 [r.p.s.]
Shipping set	: 0.01 [r.p.s.]
Default	: Not omissible

- Sets Home Return near-zero velocity.
- “TS” or “?HZ” command reports the current setting.

***ID* : Incremental Positioning, Degree**

Format	: ID data
Data	: -99999999 ~ +99999999 [0.01°]
Default	: 0

- Executes the incremental positioning command (in units of degrees) in the RS-232C communication operation.
- Data is in the units of 0.01°.
- The data sign specifies the direction of rotation.
 - data > 0: plus direction (CW)
 - data < 0: minus direction (CCW)Example: ID-10000: The Motor turns 100° in the minus direction

★ *ILV* : Integration Limit

Format	: ILV data
Data	: 0.0 ~ 100.0 [%]
Shipping set	: 100

- Provides the velocity loop integration with a limiter.
- For more details, refer to “8.2.4. Integrator Limit : ILV”.
- “TS” or “?ILV” command reports the current setting.

***IN* : In-position**

Format	: IN data
Data	: 0 ~ 99 999 999 [pulse]
Shipping set	: 100
Default	: 0

- Specify an in-position width (criterion of detecting completion of positioning). If the position error counter reads a value below the IN set value, the IPOS is output.
- “TS” or “?IN” command reports the current setting.
- When the resolver is set to 10-bit resolution, the resolution becomes one-fourth of the 12-bit setting. Therefore, only a multiple of 4 can be set (valid) as IN data.

IO : Input /Output Monitor

Format : IO data opt
Data : data = default or 0 --- Indicates CN2 input/output status.
data = 1 ----- Indicates CN2 input/output status.
(B contact input indication is reversed.)
data = 2 ----- Indicates input/output status in programmed operation.
data = 3 ----- Indicates input/output status in Jog operation.
Option code : opt = default ----- Indicates current status.
opt = /RP ----- Reading is repeated automatically.

- Indicates the status of control input/output signal (on/off , open/closed) by 1s and 0s.
1 : Input on, output closed
0 : Input off, output open
- To terminate IO/RP repeated automatic reading, press **BS** key.
- For more details, refer to “8.1.10.2. Monitoring I/O State”.

IR : Incremental Positioning, Resolver

Format : IR data
Data : -99999999 ~ +99999999 [pulse]
Default : 0

- Executes the incremental positioning command (in the units of pulse) in the RS-232C communication operation.
- The data sign specifies the direction of rotation (movement).
data > 0: plus direction (CW direction)
data < 0: minus direction (CCW direction)

IS : In-position Stability Timer

Format : IS data
Data : 0 or 0.3 ~ 100.0 [0.1 sec]
Default : 0

- Specifies the output condition of the positioning completion signal (IPOS).
ISO0 : The IPOS output closes in positioning if the value of the position error counter is within the IN set range.
IS data (data ≠ 0) : The IPOS output closes in positioning if the value of the position error counter is stable within the IN set range for the time specified in IS. The timer value is specified in “data” in units of 0.1 second. It may be 0.03 to 10 seconds if data is specified as 0.3 to 100.
- “TS” or “?IS” command reports the current setting.
- This parameter is invalid in the pulse train operation mode.

JA : Jog Acceleration

Format	: JA data
Data	: Motor series
	YS, JS1, JS2, RS : 0.01~40 [r.p.s/s]
	SS : 0.01~50 [r.p.s/s]
	AS, BS, JS0 : 0.01~60 [r.p.s/s]
Shipping set	: 1
Default	: Not omissible

- Sets the acceleration for Jog operation.
- “TS” or “?JA” command reports the current setting.

JP : Jump

Format	: JP data
Data	: 0 ~ 63
Default	: 0

- “JP” is used to specify the destination channel of unconditional jumping in a internal program.
- If a channel with a “JP” command is executed, processing jumps to channel “data” unconditionally.
- The “JP” command may be input under the condition where a channel to be programmed is selected with a “CH” command, the Driver Unit outputs “?” and the system waits for a command to be entered. If it is entered in the normal stand-by state, an error occurs. (normal stand-by state: a colon “:” is displayed)
- “TC” command reports current setting.

JV : Jog Velocity

Format	: JV data
Data	: Motor series
	YS, JS1, JS2, RS : 0.01~3.00 [r.p.s]
	SS : 0.01~3.75 [r.p.s]
	AS, BS, JS0 : 0.01~4.50 [r.p.s]
Shipping set	: 0.1
Default	: 0

- Sets the velocity for Jog operation.
- “TS” or “?JV” command reports the current setting.

LG : Lower Velocity Gain

Format	: LG data
Data	: 0 ~ 100 (%)
Shipping set	: 0
Default	: 0

- Sets velocity loop proportional gain (VG) lowering ratio when IOFF input is activated.
- However, LG is invalidated when an excessive position error alarm is issued.

LO : Load Inertia

Format	: LO data
Data range	: 0.000 ~ 50.000 [kgm ²]
Shipping set	: 0
Default	: 0

- This sets the actual load inertia automatically when the automatic tuning is performed.
- “TS” or “?LO” command reports the current setting.

★ LR : Low Torque Ripple

Format	: LR data
Data range	: 0, 1
Shipping set	: 0
Default	: 0

- Selects the characteristics of the Motor torque output.
 - 0: Standard
 - 1: Low torque ripple. (the maximum Motor torque will be lowered)
- “TS” or “?LR” command reports the current setting.

MA : Move Acceleration

Format	: MA data
Data	: Motor series
	YS, JS1, JS2, RS : 0.01~40 [r.p.s/s] or /AJ (Adjust mode)
	SS : 0.01~50 [r.p.s/s] or /AJ (Adjust mode)
	AS, BS, JS0 : 0.01~60 [r.p.s/s] or /AJ (Adjust mode)
Shipping set	: 1.00 [r.p.s/s]
Default	: Not omissible

- Sets the rotational acceleration of the RS-232C communication positioning.
- “TS” or “?MA” command reports the current setting.
- “MA/AJ” command gets into adjusting mode.

MI : Read Motor ID

Format	: MI
--------	------

- MI indicates the system ROM ID No. and the torque ROM ID No.

★ **MM : Multi-line Mode**

Format : MM data
Data : 0, 1
Shipping set : 1
Default : 0

- Sets the display format of commands or parameters settings with “TA”, “TC” and “TS” commands.
- “MM0” reports all contents continuously.
- When “MM1” is input, the display reports the setting pausing at each item. At this time, the colon “:” appears the end of command or parameter.
[Example: MA0.01:]
 - To step to the next report, press the space key.
 - To quit from the report, press the backspace key. The colon “:” appears in the display and the system waits for next command.
- “TS” or “?MM” reports the current setting.

MN : Monitor

Format : MN data
Data : 0 ~ 7
Shipping set : 0
Default : 0

- Selects and sets the condition of the analog monitor.
- The setting is not backed-up in the memory. “MN” command must be entered when monitoring is required.
- Setting can be read by “?MN” command.
- The condition of monitor is shown in the table below.

MN data	Monitor output
MN 0	Velocity
MN 1	Velocity command
MN 2	Velocity error
MN 3	Torque command
MN 4	Phase C current command
MN 5	Position command
MN 6	Position error (± 127 pulses / $\pm 10V$)
MN 7	Position error (± 1638 pulses / $\pm 10V$)

MO : Motor Off

Format : MO

- When the SVON input (CN2) is ON and the Motor is in the servo-on state, inputting the “MO” command turns the Motor servo off.
- To activate the Motor servo, input the “SV” command or the “MS” command.
- When the “MS” command is input, the Motor stops in the servo-on state. This also clears the previously input operation command.

MS : Motor Stop

Format : MS

- When the “MS” command is input during the execution of an operation, the Motor abandons the programs and stops. At this time, the Motor is in the servo-on state.
- The programs specified before the Motor stop is cleared. If the “MO” command is input to turn off the Motor servo, inputting the MS command sets the Motor to servo-on again. This also clears the programs executed preceding the input of the “MO” command.

MT : Factory Use Only

Shipping set : Already set properly for every system.

Caution : Do not change the setting since the parameter is properly set at the plant.

- “TS” or “?MT” command reports the current setting.

MV : Move Velocity

Format : MV data

Data : Motor series

YS, JS1, JS2, RS : 0.01~3.00 [r.p.s] or /AJ (Adjust mode)

SS : 0.01~3.75 [r.p.s] or /AJ (Adjust mode)

AS, BS, JS0 : 0.01~4.50 [r.p.s] or /AJ (Adjust mode)

Shipping set : 1.00 [r.p.s.]

Default : Not omissible

- Sets the rotational velocity of the Motor in the RS-232C communication positioning command.
- “TS” or “?MV” command reports the current setting.
- “MV/AJ” command sets to adjusting mode.

NP : Notch Filter, Primary (primary notch filter frequency)

Format : NP data

Data : 0 or 10 ~ 500 [Hz] or /AJ (Adjusting mode)

Shipping set : 0

Default : 0

- NP is used to specify the frequency of the primary notch filter of the velocity loop.
- If 0 is specified, the primary notch filter of the velocity loop is deactivated. In such a case, “PRI.NF OFF” is displayed.
- If a value other than 0 (i.e., 10~500) is entered, the value is adopted as the frequency.
- “TS” or “?NP” command reports the current setting.
- “NP/AJ” command sets to adjusting mode.

★ **NW** : **Neglect Width**

Format	: NW data
Data	: 0 ~ 4
Shipping set	: 2
Default	: 0

- RUN and HOS are edge-triggered inputs. To protect against multiple inputs due to contact chattering, the NW parameter sets a timer length to confirm the receipt of that input; when NW data is specified, the input pulse is detected a specified time after it initially went high (rising edge).
Timer = data × 2.8 [ms]
- “TS” or “?NW” command reports the current setting.

OE **Sequence Option Edit**

Format	: OE data
Data	: * or &
Default	: Not omissible

- OE changes the sequence code of a program already specified in a channel.
- If this command is entered under the condition where a channel whose sequence code shall be changed is selected with a “CH” command, the Driver Unit outputs “?” and the system waits for a command to be entered, the sequence code of the program already specified in the channel is changed into “data.” If OE is entered in the normal stand-by state, an error occurs.
- “Data” indicates the sequence code. Adding the sequence code enables to execute the positioning of next channel without selecting channel externally.
 - * After the positioning is over, “IPOS” signal is output and execute next channel’s program.
 - & After the positioning is over, output “IPOS” signal and stops. Then execute the next channel’s program when “RUN” command is input.

★ **OG** : **Origin Set**

Format	: OG
--------	------

Caution : This “OG” command is for factory use only. Do not change the setting.

★ **OL** : **Overload Limit**

Format	: OL data
Data	: 0 ~ 100
Shipping set	: Unique value for each System
Default	: 0

- Do not change the OL setting. OL is properly set for each System. If it needs to be changed, contact NSK.
- If 0 is specified, “THERMAL OFF” is displayed and this function is deactivated.
- “TS” or “?OL” command reports the current setting.

★ **OS** : *Home Return Setting Mode*

Format	: OS data
Data	: 1, 3, 4, 5
Shipping set	: 4
Default	: Not omissible

- Sets the “Home Return” mode.
 - OS1 : Completes “Home Return” at where “HLS” input goes OFF after entering “HLS” ON range.
 - OS3 : Completes “Home Return” at where the Motor advances “HO” value after going out from “HLS” ON range.
 - OS4 : Completes “Home Return” at where the Motor advances for “HO” value after entering “HLS” ON range.
 - OS5 : Completes “Home Return” at where “HLS” input goes ON.
 - Refer to “9.2.1. Home Return” for OS4 sequential chart.
 - The Home Return setting can be checked with “TS” or “?OS” command.
-

★ **OTP** ★ **OTM** : *Overtravel Limit Switch Position*

Format	: OTP data, OTM data
Data	: -99999999 ~ +99999999 [pulse]
Shipping set	: OTP0, OTM0
Default	: 0

- Sets the software overtravel limit values in the position coordinate.
 - OTP : Sets the overtravel limit value in the plus direction in the units of pulse.
 - OTM : Sets the overtravel limit value in the minus direction in the units of pulse.
 - “OTP/ST” and “OTM/ST” command enables to set the position by teaching. (For more details, refer to “8.1.5.2. Software Overtravel Limit Switch”.)
 - “TS” or “?OTP”, “?OTM” command reports the current setting.
-

★ **PA** : *Phase Adjust*

Format	: PA data
Data	: 24 ~ 1048
Shipping set	: 700
Default	: 0

- Sets the compensation value of the resolver installation position.
- The resolver is set to the optimum installation position before shipment. Do not input PA in normal use.
- “TS” or “?PA” command reports the current setting.

★ PC : Pulse Command

Format : PC data
Data : 0 ~ 4
Shipping set : 0
Default : 0

- Sets the format of the pulse train input.
 - PC0: CW & CCW format
 - PC1: Pulse & direction format
 - PC2: $\phi A/\phi B$ input $\times 1$ format
 - PC3: $\phi A/\phi B$ input $\times 2$ format
 - PC4: $\phi A/\phi B$ input $\times 4$ format
- “TS” or “?PC” command reports the current setting.

PG : Position Gain

Format : PG data
Data : 0.010 ~ 1.000 or /AJ (adjusting mode)
Default : Not omissible

- Sets proportional gain of the position loop.
- “TS” or “?PG” command reports the current setting.
- “PG/AJ” command sets to the adjusting mode.

★ PH : Programmed Home Return

Format : PH data
Data : 0----- Automatic Home Return invalid
1----- Execute Home Return only once when the power is turned on and the Home position is not certain.
2----- Execute Home Return every time before execution of the programmed operation.
Shipping set : 0
Default : 0

- This is to execute Home Return operation automatically before the programmed operation is performed.
- The setting makes “HS” command unnecessary and can save one channel program area.
- “TC/AL” or “?PH” command reports the current setting.

★ **PS** : **Position Scale**

Format	: PS data
Data	: 0, 1, 2 ~ 99
Shipping set	: 1
Default	: 0

- Specifies the internal position scale type of the Megatorque Motor system.
 - PS0 : Linear position scale
 - PS1 : Single-rotation position scale
 - PS2 to 99 : Multi-rotation position scale
- “For more details, refer to “8.2.1. Position Scale”.
- “TS” or “?PS” command reports the current setting.

RA : **Read Analog Command**

Format	: RA RA/RP
--------	---------------

- Reads the analog command value when an analog command is valid.
- “RA” input reports reading only once. “RA/RP” reports the reading continuously. To quit from the continuous reading, press **BS** key.
- “RA INHIBITED” message will be returned when an analog command is invalid.
- The report is a decimal number in -2048 ~ 2047.
- The report includes the result of dead band setting when “DBA” (dead band) is set to an analog command.

★ **RC** : **Rated Current (Software Thermal)**

Format	: RC data
Data	: 0 ~ 100
Shipping set	: Unique value for each Motor
Default	: 0

- Do not change the RC setting. RC is properly set for each Motor. If it needs to be changed, contact NSK.
- “TS” or “?RC” command reports the current setting.

★ **RI** : **Factory Use Only**

Shipping set	: Set properly to each Motor.
--------------	-------------------------------

Caution : Do not change setting. It is properly set for each Motor at the factory.

- “TS” or “?RI” reports the current setting.

★ **RR** : **Resolver Resolution**

Format	: RR data
Data	: 0, 1, -1
Shipping set	: -1
Default	: 0

- Sets the resolution of the resolver.
 - RR0 : 10-bit setting
 - RR1 : 12-bit setting
 - RR-1 : Automatic resolution switching
- For details of resolution, refer to “3.2.3. Functional Specification”.
- “TS” or “?RR” command reports the current setting.

SG : **Servo Gain Adjust, Minor**

Format	: SG data
Data	: 0 ~ 30 [HZ] or /AJ (Adjust mode)
Shipping set	: 0
Default	: Not omissible

- Sets position loop gain in the automatic tuning minor adjustment.
- When “SG” value is changed, “PG” (position loop proportional gain), “VG” (velocity loop proportional gain) and “VI” (velocity loop integration frequency) parameter settings will be automatically revised.
- “SG/AJ” command sets to the adjusting mode.
- “TS” or “?SG” reports the current setting.

★ **SI** : **Set Initial Parameters**

Format	: SI/data
Data range	: None, AL, SY
Default	: None

- Resets parameters to the shipping set value.
- The “SI” command can be input only immediately after inputting the password and when the Motor is servo-off.
- The following parameters will be initialized by SI:
 - SI : Initializes servo-related parameters (PG, VG, VI, DBP, ILV, FF, FP, FS, NP, LG, TL, SG, LO, FO, FC))
 - SI/AL : Initializes all the parameters.
 - SI/SY : Initializes all the parameters excluding PA.
- * Executing “SI/AL” entails resolver phase adjustment. Be careful that the Motor is not locked by an external force. Do not perform initializing only to the Driver Unit.

Caution : *System initialization takes about 30 seconds. Do not turn off the power while initialization is being performed. Otherwise, the memory will become faulty.*

- * When the memory is faulty, SI/AL will be executed even if SI or SI/SY is input.

★ SL : Set Servo Loop

Format : SL data
Data : 1, 2, 3
Shipping set : 3
Default : Not omissible

- Sets the control mode.
 - SL1: Torque control mode
 - SL2: Velocity control mode
 - SL3: Position control mode
- Position control mode is valid immediately after inputting this command.
- “TS” or “?SL” command reports the current setting.

SP : Start Program

Format : SP data
Data range : 0 ~ 15 or /AJ (Adjust mode)
Default : 0

- Executes the program of a channel specified on “data”.
- “SP/AJ” command executes the demonstration program (back and forth operation).

SV : Servo-on

Format : SV

- When the Motor servo is turned off by “MO” command, executing the “SV” command will turn the Motor servo on.
- To turn the Motor servo on by the “SV” command, the SVON input of CN2 must be on.

TA : Tell Alarm Status

Format : TA

- Reports alarm status.
- No display is shown when any alarm is not issued.
- When an alarm is detected, the display identifies an alarm as shown in the table below.

Alarm	7 segments LED	Terminal Display
Memory Error	E0	E0>Memory Error
EEPROM Error	E2	E2>EEPROM Error
Interface error	E8	E8>I/F Error
Analog command error	E9	E9>ADC Error
Excess Position Error	F1	F1>Excess Position Error
Software Over Travel Limit	F2	F2>Software Over Travel
Hardware Over Travel Limit	F3	F3>Hardware Over Travel
Emergency Stop	F4	F4>Emergency Stop
Program Error	F5	F5>Program Error
Automatic Turing Error	F8	F8>AT Error
Resolver Circuit Error	A0	A0>Resolver Circuit Error
Software Thermal Sensor	A3	A3>Overload
Heat Sink Overheat or Regeneration Resistor Overhat	P0	P0>Over Heat
Abnormal Main AC Line Voltage	P1	P1>Main AC Line Trouble
Over Current	P2	P2>Over Current
Control AC Line Under Voltage	P3	P3>Control AC Line Under Voltage

- When two or more alarms are detected, each alarm is displayed on a separate line.
- Display mode set by “MM” parameter is valid.
- Display example (Emergency stop and hardware over travel limit alarm are detected in MM1 setting.)

```
:TA  
F3>Hardware Over Travel;  
F4>Emergency Stop;  
:
```

TC : Tell Channel Program

Format : TC data

Data : 0 ~ 15 or /AL

Default : 0

- Reports the program contents of a channel specified on “data”.
- No data is displayed if program is not set to the channel.
- “TC/AL” command is to scroll all channels with pressing the space key.

TE : Tell Position Error Counter

Format : TE/RP

- Reads the value of the position error counter. The displayed value is between - 2 147 483 648 and +2 147 483 647. If it exceeds or lowers below the upper or lower limit, it is changed into the lower or upper limit with a reversed sign.
- When only “TE” is entered, the display shows the value at the moment.
- If an /RP option is added to a “TE” command, reading is repeated automatically.
- In automatic reading, a value consisting of up to six figures is read out. If a value consists of more than six figures, “*****” is displayed.
- To terminate automatic reading, press the **[BS]** key.

★ TL : Torque Limit Rate

Format : TL data

Data : 0 ~ 100 [%]

Shipping set : 100

Default : 0

- Sets the torque limit.
- The Motor torque will be reduced to a percentage (%) of the maximum torque immediately after “TL” is input and the Motor torque is controlled not to exceed the limit.
- “TS” or “?TL” reads the current setting.

TP : Tell Position

Format : TP data/RP

Data : 2, 5

Shipping set : None

Default : Not omissible

- “TP” command reads the current position of the Motor in the position coordinate set by PS parameter.
- If /RP is executed with an /RP option, reading is repeated automatically.
- If only “TP data” is executed, the display shows the position at the moment.
- To terminate automatic reading, press the **[BS]** key.
- TP2/RP: in the units of pulse
 - YS, JS1, JS2, RS : 614400 pulses/revolution
 - SS : 491250 pulses/revolution
 - AS, BS, JS0 : 409600 pulses/revolution
- TP5/RP: in the units of 0.01°
36000/revolution

TR : Tell RDC Position Data

Format : TR/RP

- TR reads data of RDC position data.
- Data is between 0 and 4095.
- If TR command is executed with /RP option, reading is repeated automatically.
- To terminate automatic reading, press the **[BS]** key.
- “TR” command reads out the status at the moment.

TS : Tell Settings

Format : TS data

Data : 0 ~ 12

Default : 0

- Reads the parameters. The parameters to be read vary with data.
 - TS0: All the following parameters
 - TS1: PG, VG, VI, VM, LG, TL
 - TS2: FO, FP, FS, NP, DBP, DBA, ILV, FF, FC
 - TS3: CO, IN, IS, FW
 - TS4: CR, PC, RR
 - TS5: FD, FZ, FR
 - TS6: PS, DI, OTP, OTM
 - TS7: MV, MA, JV, JA, HV, HA, HZ
 - TS8: OS, HD, HO
 - TS9: PA, OL, RC, LR
 - TS10: AB, NW
 - TS11: MM, BM, CM, AN, WM
 - TS12: LO, SG, MT, RI, ZP, ZV
 - TS13: SL, AC, AGV, AGT
- “MM” sets the display mode.

VG : Velocity Gain

Format : VG data

Data : 0.1 ~ 255.0 or /AJ (Adjusting mode)

Shipping set : 1.0

Default : Not omissible

- Sets velocity loop proportional gain.
- “VG/AJ” command sets to adjusting mode.
- “TS” or “?VG” reports the current setting.

VI : Velocity Integrator Frequency

Format	: VI data
Data	: 0.10 ~ 63.00 [HZ] or /AJ (Adjusting mode)
Shipping set	: 1.00
Default	: Not omissible

- Sets the integration frequency of velocity loop.
- “VI/AJ” sets to adjusting mode.
- “TS” or “?VI” reports the current setting.

★ **VM : Velocity Integrator Mode**

Format	: VM data
Data	: 0, 1
Shipping set	: 1
Default	: 0

- Changes the velocity loop integrator control as shown below.
VM0: Velocity loop P control.
VM1: Velocity loop PI control.

★ **WD : Write Data to EEPROM**

Format	: WD
--------	------

- Writes all current settings of programs and parameters to EEPROM.
- Use this command when “WMI” (data back-up invalid) is set.

Caution : ● *Approximately 30 seconds are required to execute this command.*

- *Do not turn the power off while executing the command.*
- *Otherwise, memory error alarm may be issued.*

★ **WM** : **Write Mode to EEPROM**

Format : WM data
Data : 0 or 1
Shipping set : 0
Default : 0

- 100000 times of resetting/deleting parameters to EEPROM are possible as data back-up. However, frequent resetting/deleting of parameters may exceed the expected life of EEPROM. “WM” is to select data back-up mode to reduce frequency of parameter resetting/deleting.

WM0: Data back-up valid

WM1: Data back-up invalid

Caution : ● *When the setting is changed from “WM1” to “WM0”, it takes approximately 30 seconds for storing all data.*

- *Do not turn the power off while executing the command.*
- *If the power is turned off, memory error alarm may be issued.*
- When “SI” is executed, all initialized parameters are stored to EEPROM even “WM” command is set to invalid.
- “TS” or “?WM” reports the current setting.

★ **ZP** : **Factory Use Only**

Shipping set : 1.00

Caution : ● *The parameter is for the automatic tuning function and is set at the factory.*

- *Do not change the setting.*
- *“TS” or “?ZP” command reports the current setting.*

★ **ZV** : **Factory Use Only**

Shipping set : 1.4

Caution : ● *The parameter is for automatic tuning function and to be set at the factory*

- *Do not change the setting.*
- *“TS” or “?ZP” command reports the current setting.*

12. Maintenance

12.1. Precautions

- Back up Motor and Driver Unit
 - We recommend to have a back up Motor and Driver Unit for unexpected shut down of the system.
- Parameter and program back up
 - For an unexpected shut down of the Driver Unit, all parameters and programs should be recorded.
 - For your convenience, the list of parameter and program is provided in the last page of this manual.
- How to replace the driver Unit.
 - Standard ESA25 Driver Units are interchangeable with each other. It may be replaced simply by inputting same parameter settings of old Driver Unit.
Following shows reference number of standard ESA25 Driver Unit.
 - M-ESA-*****A25
 - M-ESA-***** C25
 - (***** represents Motor number. The Driver Unit to be replaced must have same number.)
- If your Driver Unit is not standard, refer to the specification documents for interchangeability.
- When replacing the Driver Unit, refer to “Appendix 3. How to replace ESA25 Driver Unit”.
- ESA25 Driver Unit has EEPROM and does not need a battery for memory back up.

(Life of EEPROM: approximately 100000 cycles of writing on and off.)

12.2. Maintenance Check

12.2.1. Motor

- Since a Megatorque Motor does not have any parts which will wear out, a daily maintenance check should be enough.
- The table below shows the maintenance check and intervals. The checking interval shown in the table is reference only. It should be decided accordingly to the actual use conditions.

Caution : Do not disassemble the Motor and resolver. If disassembling Motor is necessary, contact your local NSK representative.

Table 12-1: Motor maintenance check

Item	Checking interval	How to check	Remarks
Vibration/Noise	Daily	<ul style="list-style-type: none"> ● Touching and hearing 	<ul style="list-style-type: none"> ● Watch daily changes
Appearance	According to environment	<ul style="list-style-type: none"> ● Wipe off dust/slag ● Blow off slag 	—
Insulation	Once/year	<ul style="list-style-type: none"> ● Resistance test (Motor coil and ground earth) (Disconnect Driver Unit) 	<ul style="list-style-type: none"> ● Resistance $\geq 10M\Omega$
Full check	According to Motor condition	<ul style="list-style-type: none"> ● Overhaul (NSK) 	—

12.2.2. Driver Unit and Cable Set

- As a Driver Unit does not have any contact point and highly reliable semiconductors are used, the daily check is not necessary. Checking as shown in Table 12-2 are necessary at least once a year.

Table 12-2

Item	Interval	Check point	Remarks
Retighten screws	Once/year	<ul style="list-style-type: none"> ● Terminal block screw. ● Connector fixing screw. 	—
Cleaning	Once/year	<ul style="list-style-type: none"> ● Remove dust or contaminants inside of Driver Unit. 	—
Cable check	Once/year	<ul style="list-style-type: none"> ● Check for damages and cracks of cables. 	<ul style="list-style-type: none"> ● When the cable is forced to bend or twist, checking frequency should be increased.

12.3. Periodical Replacement of Parts

12.3.1. Motor

- There is no parts which is required to be replaced periodically.
- Refer to “12.2. Maintenance Check”.

12.3.2. Driver Unit

- Electrolytic condenser
 - The gradual chemical change of electrolytic condensers will deteriorate system function and it may result in the system failure.

Table 12-3

Parts	Function	Life	How to replace
Electrolytic condenser	Equalize power voltage	10 years	<ul style="list-style-type: none"> ● Replace *PCB ● Replace whole unit

*PCB: Printed circuit board

Note: Life of electrolytic condenser relies on the operating conditions. The 10 years of life is rough estimation under continuous operation in normal room environment.

12.4. Storing

- Store the Motor and Driver Unit in clean and dry indoor condition.
- A Driver Unit has a lot of ventilation holes and should be covered properly to protect from dust.

Table 12-4

Storing condition		Remarks
Temperature	-20°C ~ +70°C	—
Humidity	20% ~ 80%	No condensation

12.5. Limited Warranty

- NSK Ltd. warrants its products to be free from defects in material and/or workmanship which NSK Ltd. is notified of in writing within, which comes first, one (1) year of shipment or 2400 total operation hours. NSK Ltd., at its option, and with transportation charges prepaid by the claimant, will repair or replace any product which has been proved to the satisfaction of NSK Ltd. to have a defect in material and/or workmanship.
- This warranty is the sole and exclusive remedy available, and under no circumstances shall NSK Ltd. be liable for any consequential damages, loss of profits and/or personal injury as a result of claim arising under this limited warranty. NSK Ltd. makes no other warranty express or implied, and disclaims any warranties for fitness for a particular purpose or merchantability.

(Blank Page)

13. Alarm

13.1. Identifying Alarm

- The DRDY output opens when error occurs in ESA25 Driver Unit.
- The front panel is provided with a 7-segment LED display to indicate the type of alarm. Also the “TA” command can be used to identify alarms.

13.1.1. LED Alarm Indicator

Figure 13-1

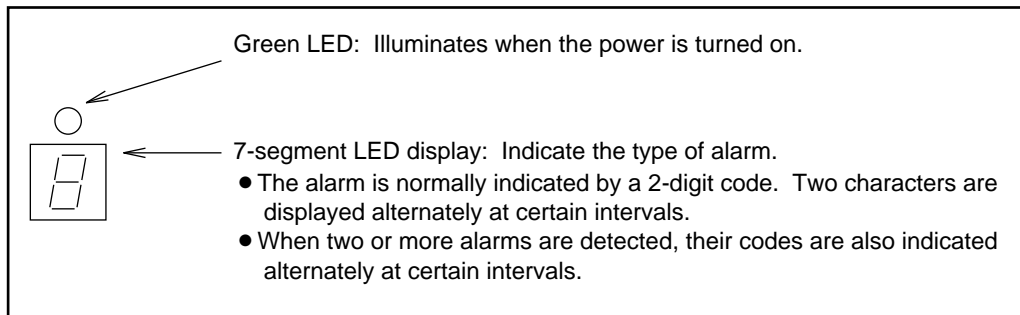
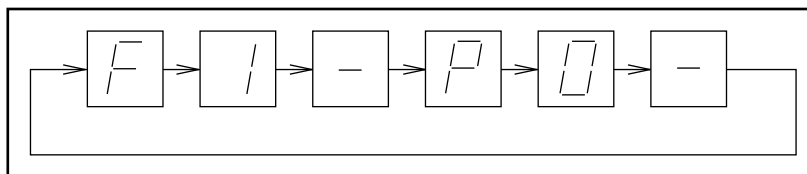
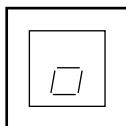

Figure 13-2: Abnormal (example)



(Example) Excess position error F1 + Heat Sink Over-Temperature P0

Figure 13-3: The LED is indicating normal state.



13.1.2. Using TA Command

- “TA” command is to display the alarm code on the Handy Terminal screen.
- In this case, the code is not displayed at different time as the LED display.
 - Example
 - Excess position error and heat sink overheat alarms will be displayed as shown in Figure 13-4.

Figure 13-4: Alarm display

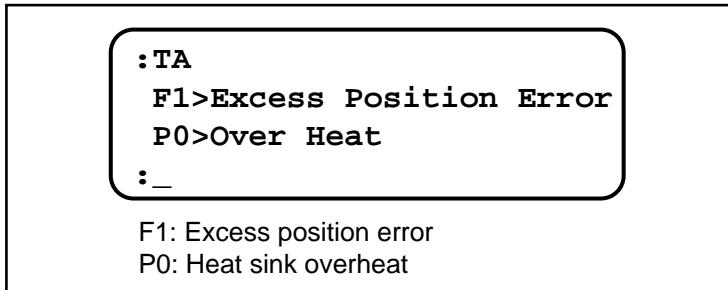

[Example 1] Alarm is detected and identify the alarm.

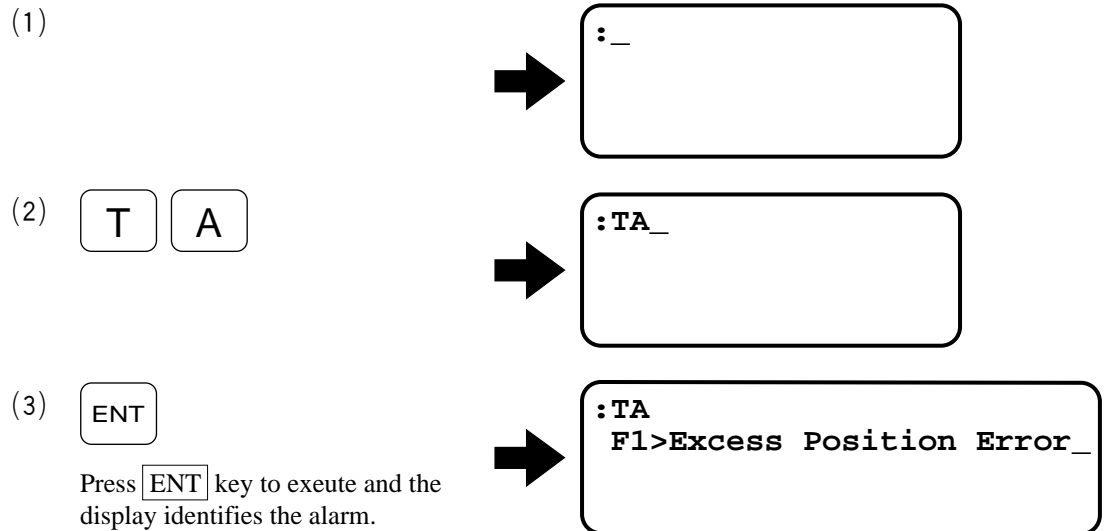

- Thus the alarm is identified as “Excess position error”.

13.1.3. Alarm Code List

- Reports alarm status.
- No display is shown when any alarm is not issued.
- When an alarm is detected, the display identifies an alarm as shown in the table below.

Table 13-1: Alarm code list

Alarm	7 segments LED	Terminal Display
Memory Error	E0	E0>Memory Error
EEPROM Error	E2	E2>EEPROM Error
Interface error	E8	E8>I/F Error
Analog command error	E9	E9>ADC Error
Excess Position Error	F1	F1>Excess Position Error
Software Over Travel Limit	F2	F2>Software Over Travel
Hardware Over Travel Limit	F3	F3>Hardware Over Travel
Emergency Stop	F4	F4>Emergency Stop
Program Error	F5	F5>Program Error
Automatic Turing Error	F8	F8>AT Error
Resolver Circuit Error	A0	A0>Resolver Circuit Error
Software Thermal Sensor	A3	A3>Overload
Heat Sink Overheat or Regeneration Resistor Overheat	P0	P0>Over Heat
Abnormal Main AC Line Voltage	P1	P1>Main AC Line Trouble
Over Current	P2	P2>Over Current
Control AC Line Under Voltage	P3	P3>Control AC Line Under Voltage

- When two or more alarms are detected, each alarm is displayed on a separate line.
- Display mode set by “MM” parameter is valid.
- Display example (Emergency stop and hardware over travel limit alarm are detected in MM1 setting.)

```

:TA
F3>Hardware Over Travel;
F4>Emergency Stop;
:
```

13.2. Details of Alarm

Caution : The DRDY output is normally closed. It opens on abnormal condition.

13.2.1. Normal State

- When the Motor does not operate even in normal state, following causes should be considered as shown in Table 13-2.

Table 13-2

Status	Motor condition	DRDY	Cause	Remedy
Power-off	Servo-OFF	open	Power is not supplied.	Turn on power.
CPU Initializing	Servo-OFF	open	Initializing the CPU.	Wait for the CPU to be initialized.
SVON Input OFF	Servo-OFF	closed	SVON input is not active.	Activate the SVON input.

13.2.2. Alarms Related to Power Amplifier

13.2.2.1. Heat Sink Overheat or Regeneration Resistor Overheat

[Output]	DRDY: Open
[TA]	P0 > Over Heat
[LED]	P0
[Motor Condition]	Servo-OFF

Table 13-3: Cause and Remedy: Heat sink over temperature

Cause	Remedy
① Duty cycles of the Motor is too high.	<ul style="list-style-type: none"> Reduce the load and/or operation duty. Readjust acceleration/deceleration. (Stop operation, air-cool the Driver Unit.)
② Excessive load is applied.	
③ Ambient temperature is above 50°C.	<ul style="list-style-type: none"> Check surrounding condition of the Driver Unit. Stop the operation and air-cool the Motor and Driver Unit. Then check followings. <ul style="list-style-type: none"> Whether the duty cycle is too high. Whether excessive load is applied. If no troubles are found in the above check and this alarm occurs frequently, contact NSK.
④ Heat sink temperature exceeds 90°C due to continued heavy torque demand.	
⑤ Defective PCB. (As soon as the control power is turned on, the alarm is activated.)	<ul style="list-style-type: none"> Replace Driver Unit. (Refer to “Appendix 3. How to Replace ESA25 Driver Unit”.)

Notes: (1) Stop operation immediately.

(2) Even the alarm is deactivated, it is activated again when the thermal sensor is still on.

- Take enough time to air-cool the Motor and Driver Unit.

13.2.2.2. Abnormal Main AC Line Voltage

[Output]	DRDY: Open
[TA]	P1 > Main AC Line Trouble
[LED]	P1
[Motor Condition]	Servo-OFF

Table 13-4: Cause and Remedy: Abnormal main AC line voltage (Over/Under)

Cause	Remedy
① Abnormal power supply voltage.	<ul style="list-style-type: none"> ● Check main power supply. (Excessive voltage, low voltage and power source capacity.)
② ○ Main circuit voltage is excessive due to high acceleration/ deceleration under heavy load. ○ Defective power source gives over 290V to the main power supply for power amplifier main circuit.	<ul style="list-style-type: none"> ● Check fuse, power source and the cable, then turn power on again.
③ Defective power source gives under 40V to power amplifier main circuit.	
④ Blown fuse. (Motor over temperature, abnormal power supply wiring, Driver Unit abnormal.)	<ul style="list-style-type: none"> ● Check blown fuse. ● Check the fuse, power supply and cables, then turn on power again.
⑤ Excessive regeneration voltage.	<ul style="list-style-type: none"> ● Readjust operation duty, the load and acceleration/deceleration.
⑥ Defective PCB. (When the alarm is on after the Motor stops even power source and fuse are normal.)	<ul style="list-style-type: none"> ● Replace Driver Unit. (Refer to “Appendix 3. How to Replace ESA25 Driver Unit”.)

Notes: (1) When the regeneration dump resistor can not process regenerative current, the voltage of direct current to main circuit will be too high and the alarm will be on.

(2) Decrease acceleration/deceleration.

13.2.2.3. Over Current

[Output] DRDY: Open
 [TA] P2 > Over Current
 [LED] P2
 [Motor Condition] Servo-OFF

Table 13-5: Cause and Remedy: Over current

Cause	Remedy
① Poor insulation of the Motor. (Refer to “Appendix 2. How to Check Motor Condition”.)	<ul style="list-style-type: none"> ● Replace Motor.
② Defective Motor Cable. (Refer to “Appendix 2. How to Check Motor Condition”.)	<ul style="list-style-type: none"> ● Replace Cable.
③ Defective FET of Power Amplifier. (When the alarm is on even the Motor and Motor cable are normal.)	<ul style="list-style-type: none"> ● Replace Driver Unit. (Refer to “Appendix 3. How to Replace ESA25 Driver Unit.”.)

Note: The alarm may be accompanied with abnormal main AC line voltage (blown fuse) alarm due to excessive current flow.

13.2.2.4. Control AC Line Under-Voltage

[Output] DRDY: Open
 [TA] P3 > Control AC Line Under Voltage
 [LED] P3
 [Motor Condition] Servo-OFF

Table 13-6: Cause and Remedy: Control AC line under-voltage

Cause	Remedy
① Low voltage of control power input.	<ul style="list-style-type: none"> ● Check control power voltage. (Low voltage due to over current or output shorting.)
② Control circuit voltage for the power amplifier falls below 70V due to faulty power supply.	<ul style="list-style-type: none"> ● Turn off power, check the power supply and power cable, then turn on power again.
③ Faulty PCB. (When the alarm is on after control power is turned on.)	<ul style="list-style-type: none"> ● Replace Driver Unit. (Refer to “Appendix 3. How to Replace ESA25 Driver Unit”.)

13.2.3. Alarms Related to Motor

13.2.3.1. Resolver Circuit Error

[Output]	DRDY: Open
[TA]	A0 > Resolver Circuit Error
[LED]	A0
[Motor Condition]	Servo-OFF

Table 13-7: Cause and Remedy: Resolver circuit error

Cause	Remedy
① Resolver cable disconnected. (Refer to “Appendix 2. How to Check Motor Condition”.)	<ul style="list-style-type: none"> ● Turn off power, check the resolver cable and connector.
② Breakage of resolver cable. (Refer to “Appendix 2. How to Check Motor Condition”.)	<ul style="list-style-type: none"> ● Replace resolver cable.
③ Faulty resolver. (Refer to “Appendix 2. How to Check Motor Condition”.)	<ul style="list-style-type: none"> ● Replace Motor.
④ Faulty PCB. (When the alarm is on even when the resolver and the cable are normal and the connector is properly secured.)	<ul style="list-style-type: none"> ● Replace Driver Unit. (Refer to “Appendix 3. How to Replace ESA25 Driver Unit”.)

- Note: (1) Check the resolver cable for disconnection and shorted of wires.
- (2) Check the connector for contact failure.
- (3) When the resolver Cable is forced to move and bend, the bending radius and frequency will affect on the life of the cable. It is necessary to have a insulation and continuity tests periodically.

13.2.3.2. Software Thermal Sensor

[Output] DRDY: Open
 [TA] A3 > Overload
 [LED] A3
 [Motor Condition] Servo-OFF

Table 13-8: Cause and Remedy: Overload

Cause	Remedy
① Excessive Motor duty cycle.	<ul style="list-style-type: none"> ● Reduce duty cycle and the load. Re-adjust acceleration/deceleration. ● The Motor is overheated and air-cooling is necessary after the Motor stops. Then turn on power. (After stopping operation, keep control power on.)
② Mechanical restraint to the Motor such as brake or an obstacle.	<ul style="list-style-type: none"> ● Remove mechanical restraint.
③ Improper gain setting.	<ul style="list-style-type: none"> ● Readjust gain. (Refer to “7. Tuning and Trial Running”.)
④ Unmatched combination of Motor and Driver Unit.	<ul style="list-style-type: none"> ● Check the combination. (Reference number of Motor and Driver Unit.)

Note: Do not change a parameter “CL” setting. It is properly set before shipment.

13.2.4. Alarms Related to Control

13.2.4.1. Memory Error

[Output] DRDY: Open
 [TA] E0 > Memory Error
 [LED] E0
 [Motion Condition] Servo-OFF

Table 13-9: Cause and Remedy: Memory error

Cause	Remedy
① Parameters stored in the memory have been rewritten by noise or other cause.	<ul style="list-style-type: none"> ● Initialize the memory then reenter the parameters. (Refer to “11. Command and Parameter”.)
② Faulty PCB. (When the memory is not functioning after initialized.)	<ul style="list-style-type: none"> ● Replace Driver Unit. (Refer to “Appendix 3. How to Replace ESA25 Driver Unit”.)

- Command “SI” initializes the memory. After initializing, some parameters are reset to shipping set. Resetting parameters are necessary.
- When the memory error occurs, read out of a parameter with “TA” command will be all “0” (Zero).

13.2.4.2. EEPROM Error

[Output] DRDY: Open
 [TA] E2 > EEPROM Error
 [LED] E2
 [Motor Condition] Servo Free

Table 13-10: Cause and Remedy: EEPROM error

Cause	Remedy
① Faulty EEPROM of control circuit.	<ul style="list-style-type: none"> • Turn the power on again. • Replace Driver Unit. (Refer to “Appendix 3. How to Replace ESA25 Driver Unit”.)

13.2.4.3. CPU Error

[Output] DRDY: Open
 [TA] Disabled
 [LED] Unstable
 [Motor Condition] Servo-OFF

Table 13-11: Cause and Remedy: CPU error

Cause	Remedy
① CPU is out of control due to noise.	<ul style="list-style-type: none"> • Turn power on again. • The alarm is deactivated when the power is turned on again. If the alarm occurs frequently, contact NSK.
② Faulty PCB. (When the alarm is not deactivated after the power is turned on.)	<ul style="list-style-type: none"> • Replace Driver Unit. (Refer to “Appendix 3. How to Replace ESA25 Driver Unit”.)

Note: (1) CPU is not functioning. RS-232C communication and other controls are disabled.

(2) Contact NSK if the alarm occurred.

13.2.4.4. Interface Error

[Output] DRDY : Open
 [TA] E8> I/F Error
 [LED] E8
 [Motor Condition] Servo-Off

Table 13-12: Cause and Remedy: Interface error

Cause	Remedy
① Defective I/O Board in Driver Unit	<ul style="list-style-type: none"> • Replace Driver Unit. (Refer to “Appendix 3. How to Replace ESA25 Driver Unit.”)

13.2.4.5. Analog Command Error

[Output] DRDY : Open
 [TA] E9 > ADC Error
 [Motor Condition] Servo-Off

Table 13-13: Cause and Remedy: Analog command error

Cause	Remedy
① Defective circuit of analog command input	<ul style="list-style-type: none"> ● Replace Driver Unit. (Refer to “Appendix 3. How to Replace ESA25 Driver Unit.”)

13.2.4.6. Excess Position Error

[Output] DRDY: Open
 [TA] F1 > Excess Position Error
 [LED] F1
 [Motor Condition] Servo Lock

Table 13-14: Cause and Remedy: Excess position error

Cause	Remedy
① Position error counter value is over “CO” setting due to mechanical restraint such as brake.	<ul style="list-style-type: none"> ● Remove mechanical restraint.
② Improper gain setting.	<ul style="list-style-type: none"> ● Readjust gain. (Refer to “7. Tuning and Trial Running”.)
③ Excessive acceleration/ deceleration.	<ul style="list-style-type: none"> ● Decrease acceleration/deceleration.
④ “CP” setting is too low.	<ul style="list-style-type: none"> ● Increase “CO” setting. ● Activate the “CLR” input to cancel alarm, then position error counter is cleared to 0 (Zero). ● Adjust servo parameters (VG, VI, PG). ● Adjust acceleration/deceleration (MA). ● Check the applied load.
⑤ Unmatched combination of Motor and Driver Unit.	<ul style="list-style-type: none"> ● Check reference number of Motor and Driver Unit.
⑥ Improper “PA” setting.	<ul style="list-style-type: none"> ● Set “PA” to 700.
⑦ Faulty PCB. (When the alarm is on even “RUN” command is not executed.)	<ul style="list-style-type: none"> ● Replace Driver Unit. (Refer to “Appendix 3. How to Replace ESA25 Driver Unit”.)

13.2.4.7. Software Over Travel Limit

[Output]	DRDY: Open
[TA]	F2 > Software Over Travel
[LED]	F2
[Motor Condition]	Servo Lock in one direction. (The Motor will only rotate in a direction opposite to that of the rotation limit.)

Table 13-15: Cause and Remedy: Software over travel

Cause	Remedy
① The Motor enters the inhibited area set by OTP and OTM	<ul style="list-style-type: none"> ● Get out of inhibited area.

Note: If the Motor can not make a full turn due to obstacle or restricted area, “OTM and OTP” must be set to the point where the Motor can stop before entering the restricted area where the alarm is activated.

13.2.4.8. Hardware Over Travel Limit

[Output]	DRDY: Open
[TA]	F3 > Hardware Over Travel
[LED]	F3
[Motor Condition]	Servo Lock in one direction. (The Motor will only rotate in the direction opposite to that of the rotation limit.)

Table 13-16: Cause and Remedy: Software over travel

Cause	Remedy
① Motor activated travel limit switch.	<ul style="list-style-type: none"> ● Get out of the restricted area.
② Mistaken setting of input port polarity.	<ul style="list-style-type: none"> ● Confirm the parameter “AB”.
③ Faulty travel limit switch or wiring.	<ul style="list-style-type: none"> ● Check the limit switch and wiring.

13.2.4.9. Emergency Stop

[Output]	DRDY: Closed
[TA]	F4 > Emergency Stop
[LED]	F4
[Motor Condition]	Servo Lock

Table 13-17: Cause and Remedy: Emergency stop

Cause	Remedy
① Mistaken setting of input port polarity.	<ul style="list-style-type: none"> ● Confirm the parameter “AB”.
② EMST is input. (A contact)	<ul style="list-style-type: none"> ● Clear EMST input after the Motor stops.
③ EMST is input. (B contact)	<ul style="list-style-type: none"> ● Input EMST on after the Motor stops.
④ Faulty wiring.	<ul style="list-style-type: none"> ● Check wiring.

13.2.4.10. Program Error

[Output] DRDY: Closed
 [TA] F5 > Program Error
 [LED] F5
 [Motor Condition] Servo Lock

Table 13-18: Cause and Remedy: Program error

Cause	Remedy
① A non-programmed channel is started.	<ul style="list-style-type: none"> ● Check the program. ● Check wiring of PRG0~PRG3 input. ● Confirm sequence.

13.2.4.11. Automatic Tuning Error

[Output] DRDY: Closed
 [TA] F8 > AT Error
 [LED] F8
 [Motor Condition] Normal Servo State

Table 13-19: Cause and Remedy: Automatic tuning error

Cause	Remedy	Terminal display
① System is in Servo-OFF when executing automatic tuning	<ul style="list-style-type: none"> ● Check input signal and execute automatic tuning again. 	AT Error 1
② EMST or Over Travel Limit is input when executing automatic tuning.		
③ Automatic tuning can not be executed due to unbalanced load.	<ul style="list-style-type: none"> ● Check the load condition. ● Set parameters manually. 	AT Error 2
④ Resonant vibration occurs due to low rigidity of the load or the mounting base.	<ul style="list-style-type: none"> ● Check the load or the mounting base. Increase rigidity. ● Set parameters manually. 	

14. Troubleshooting

14.1. Identifying Problem

- If problems do occur, check the items shown in Table 14-1.
- When reporting problems to the manufacturer, explanation of the items in Table 14-1 will help to identify the problem.

Table 14-1

	Items	Point to be checked
1	Combination of Motor and Driver Unit	● Whether Motor and Driver Unit combination is proper or not.
2	Power supply voltage	● Voltage variation of power source is in specification.
3	Trouble recurrence	● Frequency
4	Occurrence in special occasion	● When a particular command is executed. ● A particular equipment is in operation.
5	Occurrence under a particular operation	● Same position/direction ● Accelerating/decelerating
6	Alarm Code	● Which alarm is detected.

14.2. Troubleshooting

- When troubleshooting, refer to the flow chart shown below.

Figure 14-1: Troubleshooting flow

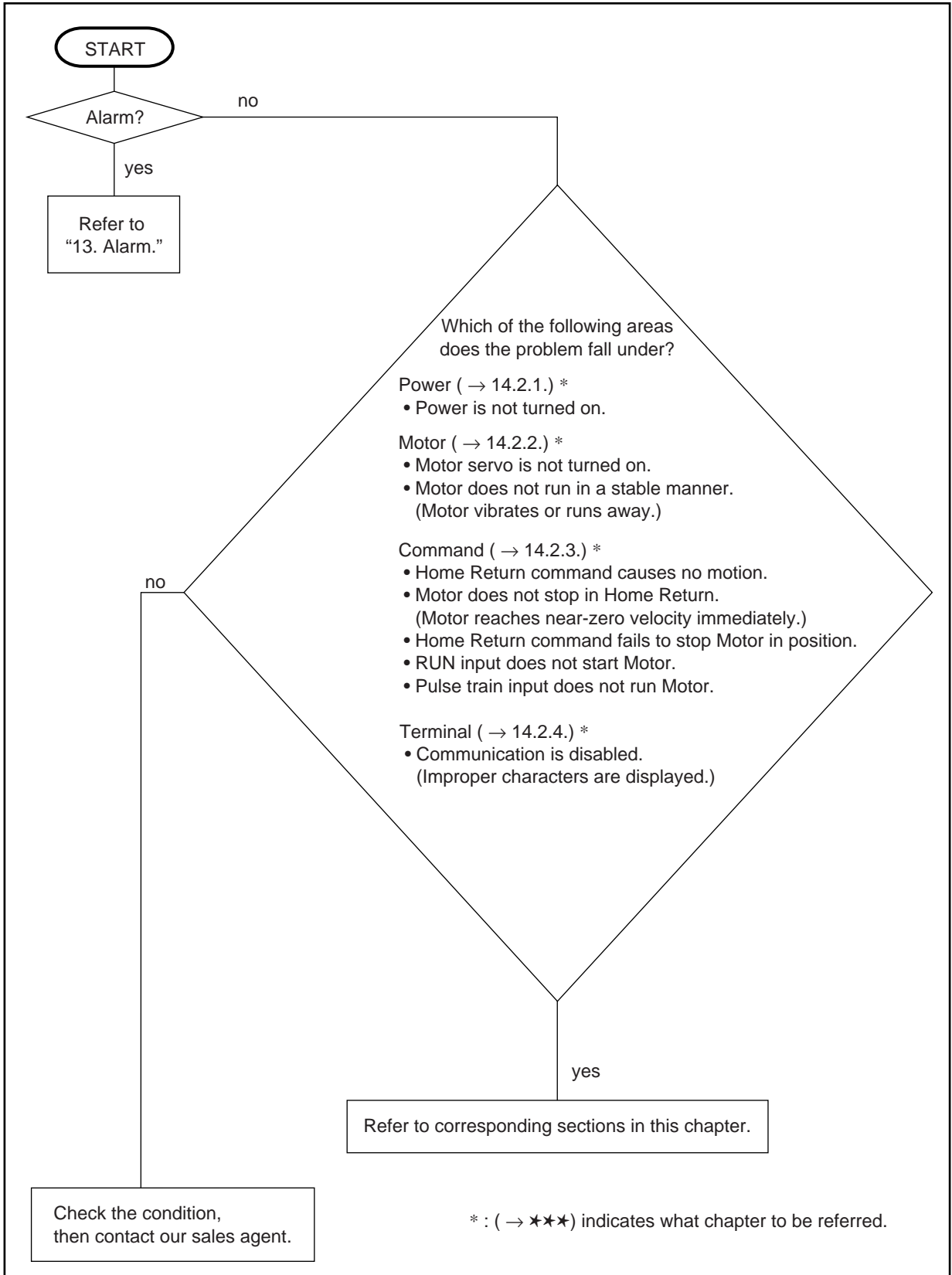

14.2.1. Power Trouble

Power is not turned on.

Figure 14-2: Power trouble

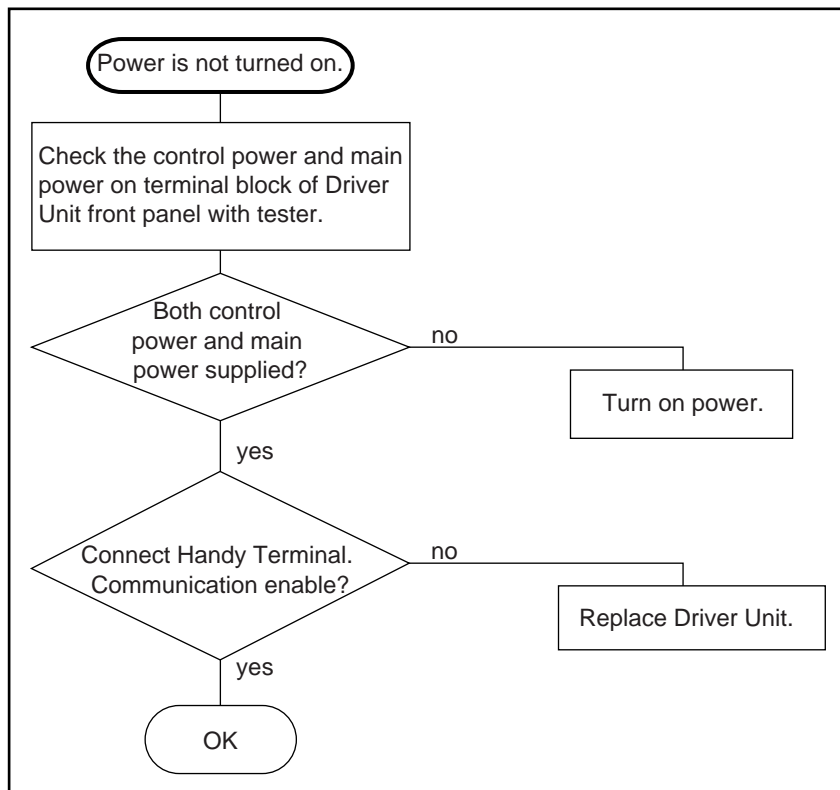

14.2.2. Motor Trouble

(1) Motor servo is not turned on.

Figure 14-3: Motor trouble 1

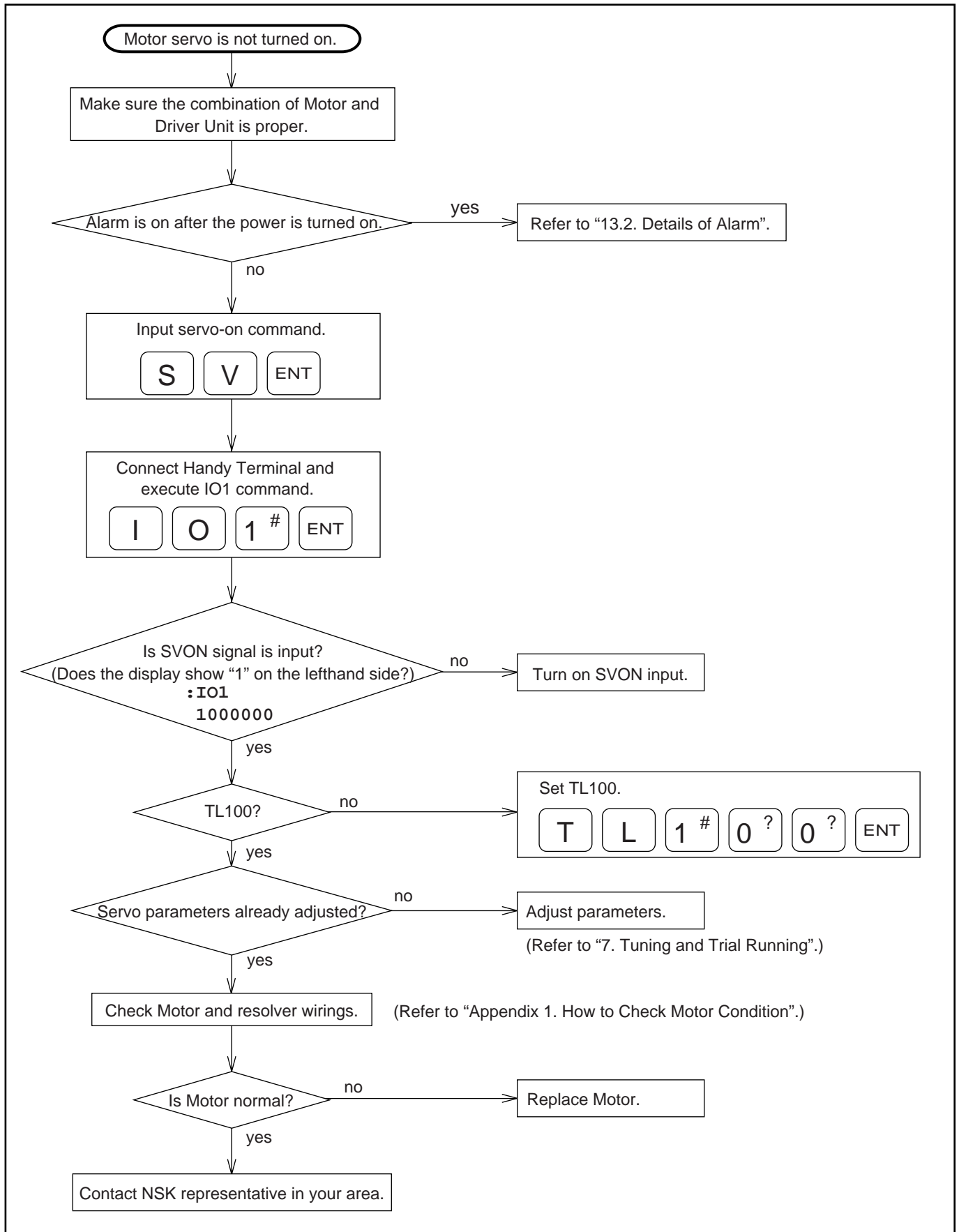

(2) **Motor does not run stably. / Motor vibrates or runs away.**

Figure 14-4: Motor trouble 2

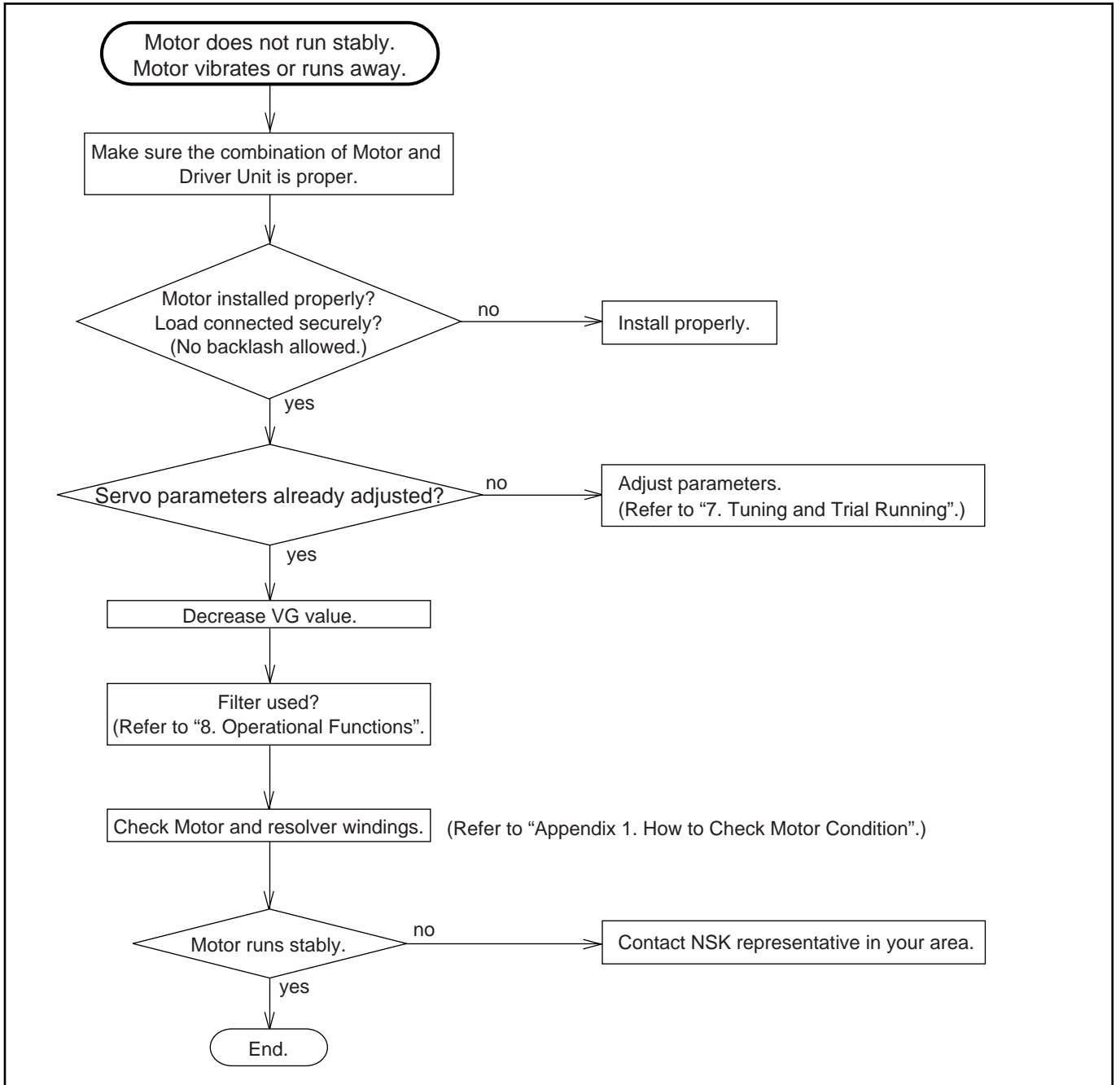

(2) **Motor does not stop in Home Return.**

Figure 14-6: Command trouble 2

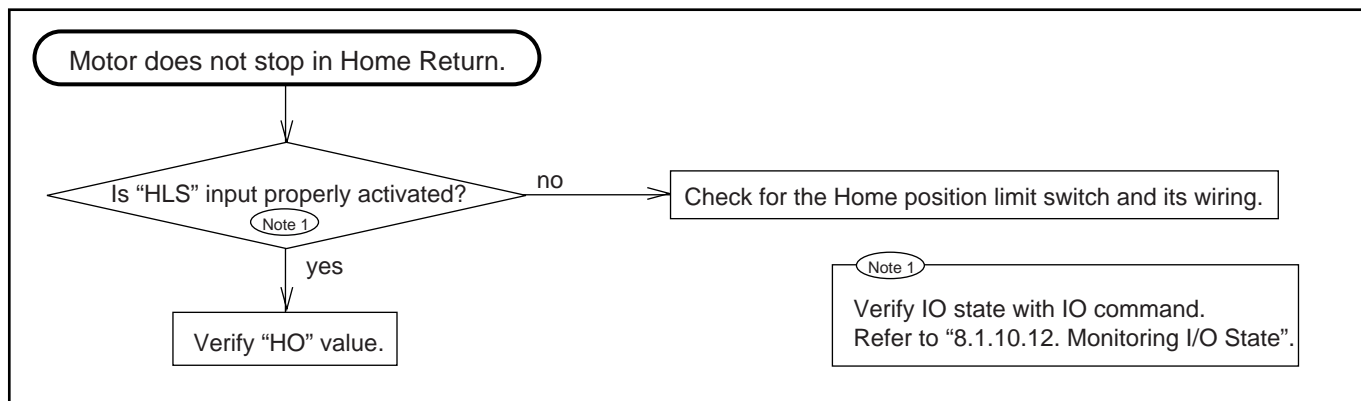

(3) **Home Return command fails to stop Motor in position.**

Figure 14-7: Command trouble 3

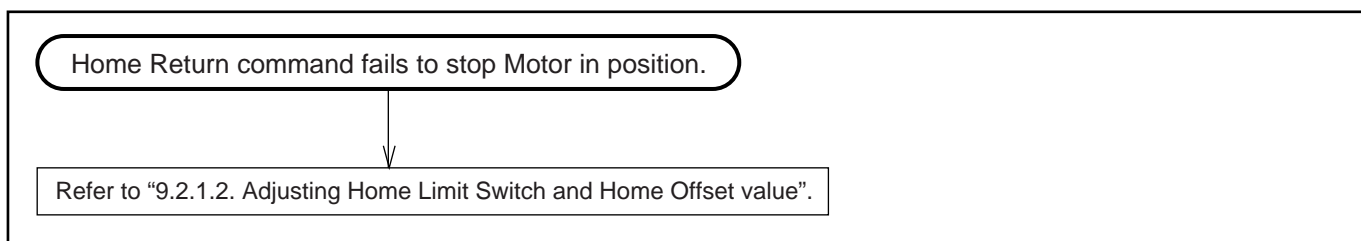

(4) Run input does not start Motor.

Figure 14-8: Command trouble 4

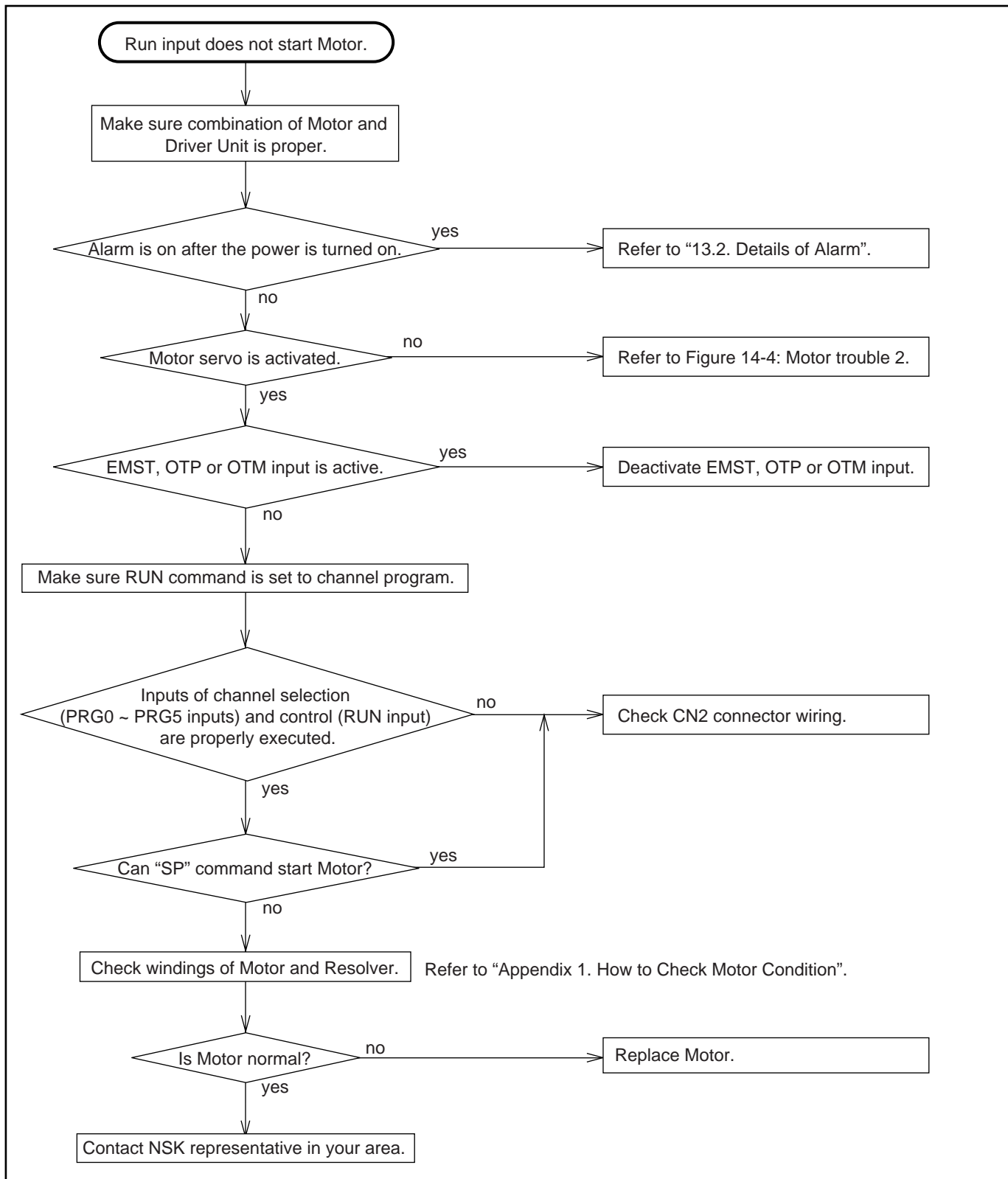

(5) **Pulse train input does not run Motor.**

Figure 14-9: Command trouble 5

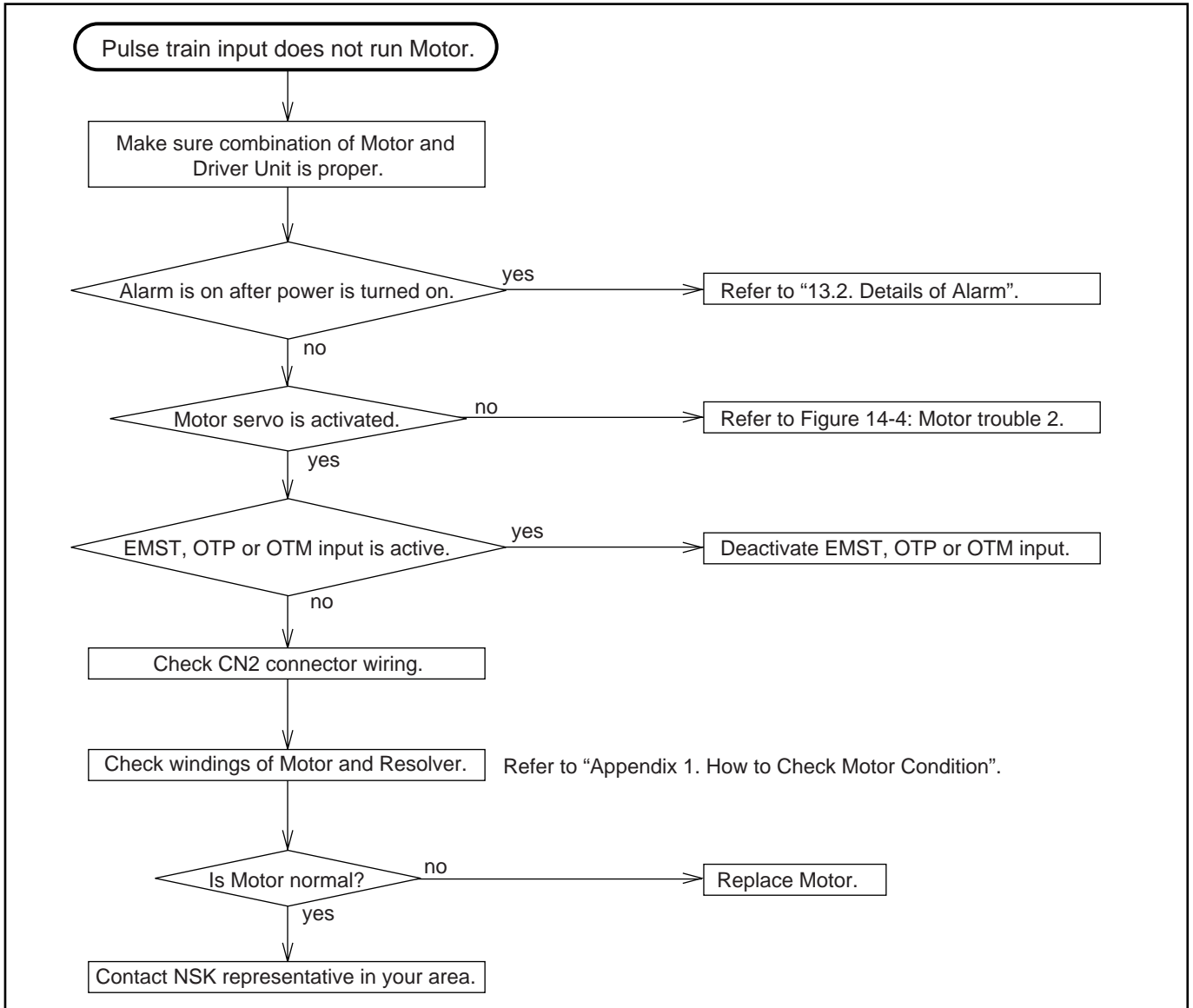

14.2.4. Terminal Trouble

Communication is Disabled

Figure 14-10: Terminal trouble

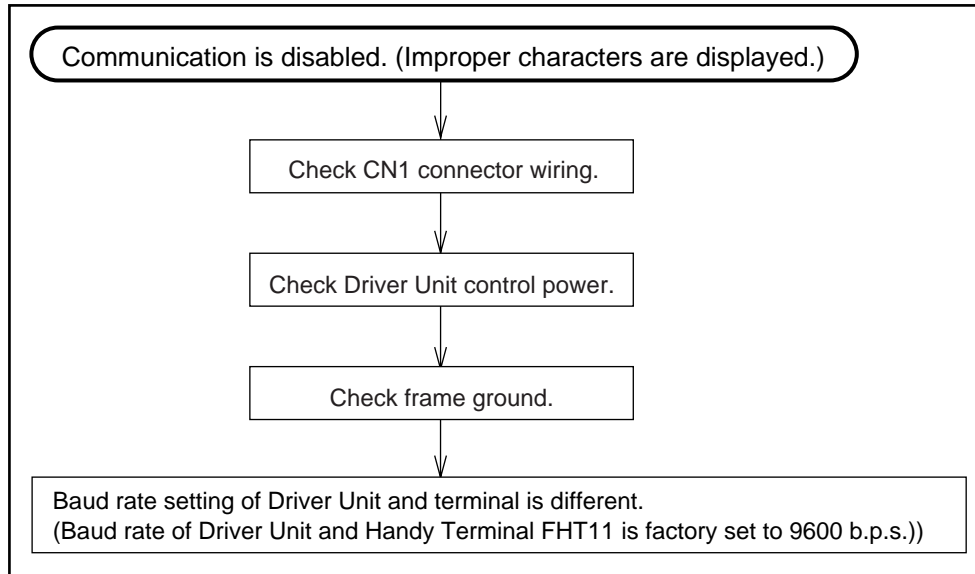

Appendix 1: How to Check Motor Condition

- Examine the resistance and isolation of Motor windings to find out its condition.
- Firstly conduct the checks with the Cable Set. If the result does not meet the specification, check the Motor only.

(1) Motor windings Resistance

Figure A-1: With Cable Set

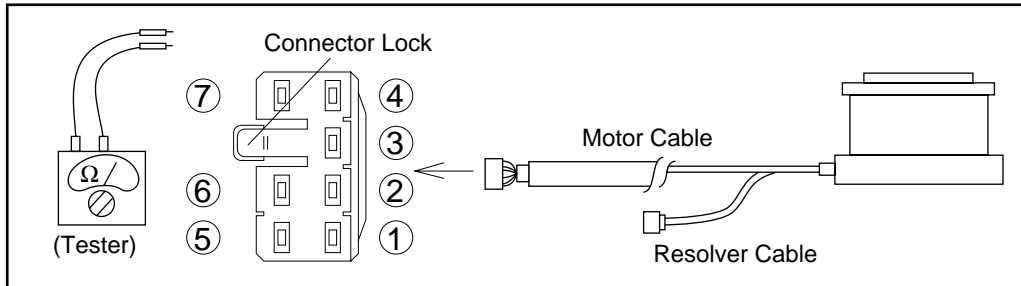

- Refer to Table A-1 for pin numbers to be checked.

Figure A-2: Motor only

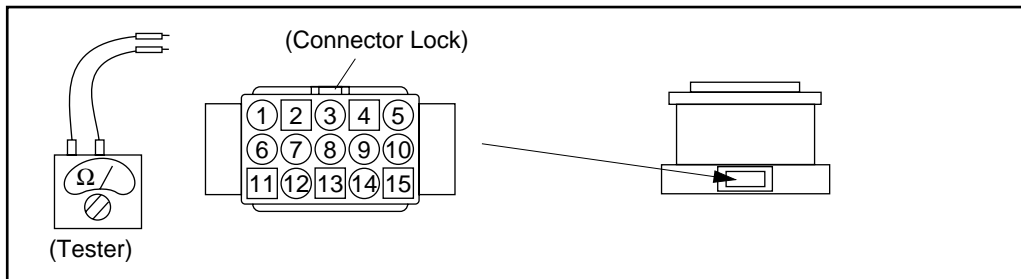

- Refer to Table A-1 for pin numbers to be checked.

Table A-1: Pin number to be checked.

	Cable connector	Motor connector	Result
Phase A	① ↔ ②	⑤ ↔ ④	
	(A+) (A-)	(A+) (A-)	
Phase B	③ ↔ ④	⑩ ↔ ⑨	
	(B+) (B-)	(B+) (B-)	
Phase C	⑤ ↔ ⑥	⑮ ↔ ⑭	
	(C+) (C-)	(C+) (C-)	

Table A-2: Specification

Motor number	Motor winding resistance (Ω)	Tolerance
YS2005	35.0	1. Allowance : ±30%
YS2020	4.5	
YS3008	47.0	2. Variations between each phase : 1Ω or less (øA, øB, øC)
YS3040	6.4	
YS4080	5.2	
YS5120	3.5	
JS0002	9.6	
JS1003	15.4	
JS2006	9.2	
JS2014	14.6	

- For special Motor windings or long cable (over 4m), contact NSK for specification.

(2) Resolver windings Resistance

Figure A-3: With cable set

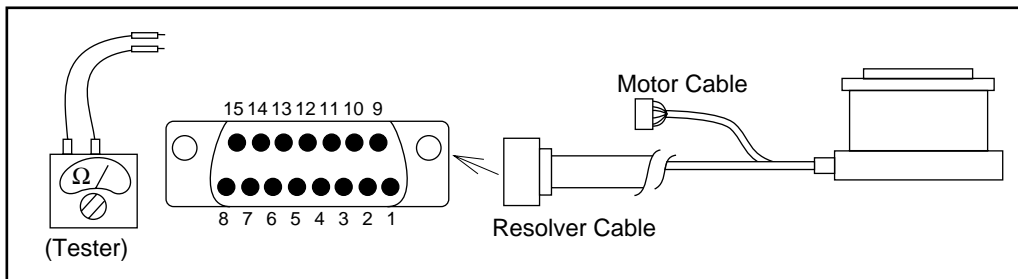

- Refer to Table A-3 for pin numbers to be checked.

Figure A-4: Resolver only

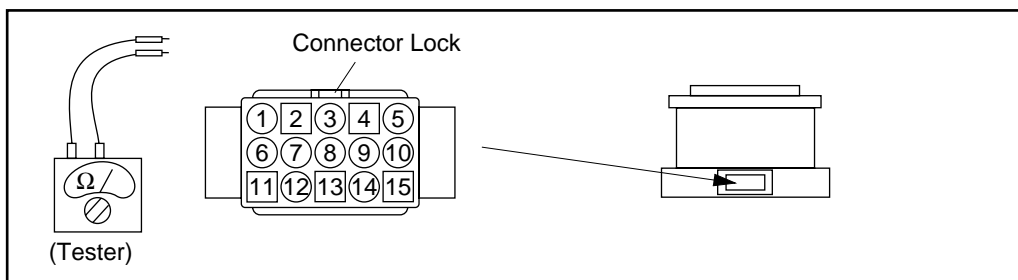

- Refer to Table A-3 for pin numbers to be checked.

Table A-3: Pin number to be checked

	Cable connector	Motor connector	Result
Phase A	⑧ ↔ ④ (REA) (COM)	① ↔ ② (REA) (COM)	
Phase B	⑦ ↔ ④ (REB) (COM)	⑥ ↔ ② (REB) (COM)	
Phase C	⑮ ↔ ④ (REC) (COM)	⑪ ↔ ② (REC) (COM)	

Table A-4: Specification

Motor number	Resolver winding resistance (Ω)	Tolerance
YS2005	3.8	1. Allowance : ±30% 2. Variations between each phase : 1.0Ω or less (øA, øB, øC)
YS2020	3.8	
YS3008	3.7	
YS3040	3.7	
YS4080	2.8	
YS5120	2.6	
YS5240	2.6	
JS0002	2.3	
JS1003	2.6	
JS2006	3.9	
JS2014	3.8	

- For special Motor windings or long cable (over 4m), contact NSK for specification.

Figure A-5: Resolver wiring (For your reference)

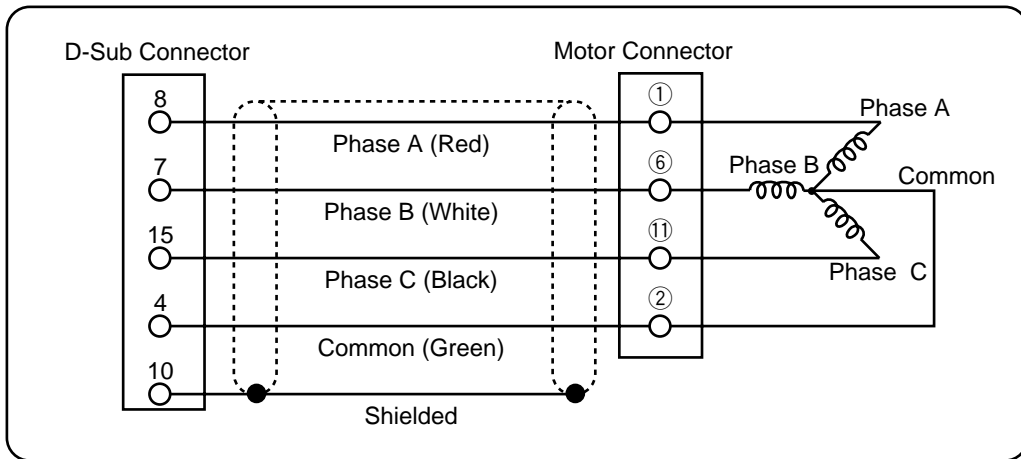

(3) Motor Windings Isolation

Caution : Disconnect Driver Unit from Motor when conducting resistance test.

Caution : Do not apply more than DC500V.

Figure A-6: With Cable Set

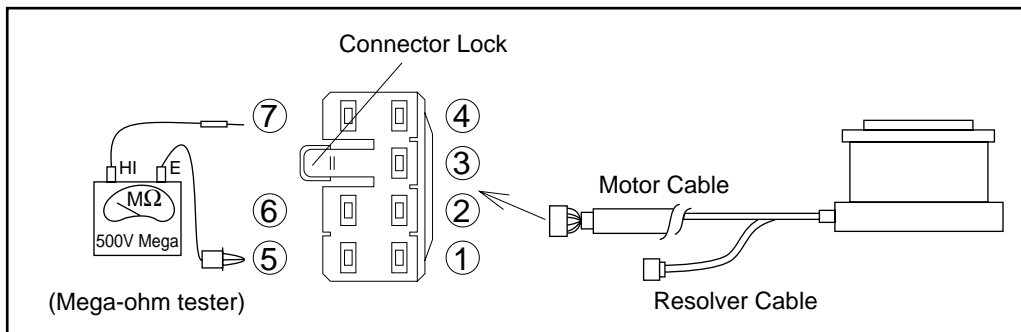

Figure A-7: Motor only

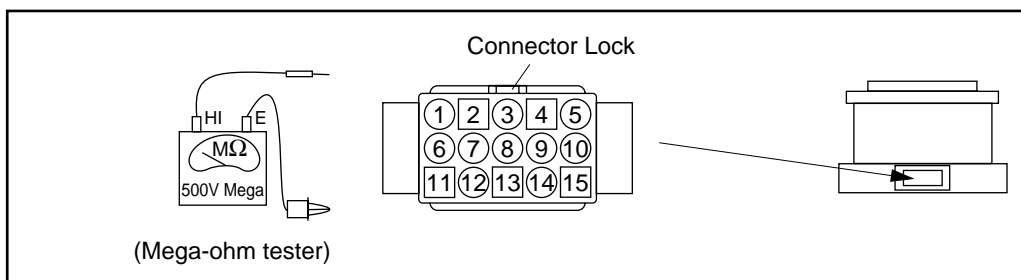

Table A-5: Pins to be checked

	Cable connector	Motor connector	
Phase A — FG	① ↔ ⑦ (A+) (FG)	⑤ ↔ ⑬ (A+) (FG)	
Phase B — FG	③ ↔ ⑦ (B+) (FG)	⑩ ↔ ⑬ (B+) (FG)	
Phase C — FG	⑤ ↔ ⑦ (C+) (FG)	⑮ ↔ ⑬ (C+) (FG)	
Phase A — B	① ↔ ③ (A+) (B+)	⑤ ↔ ⑩ (A+) (B+)	
Phase B — C	③ ↔ ⑤ (B+) (C+)	⑩ ↔ ⑮ (B+) (C+)	
Phase C — A	⑤ ↔ ① (C+) (A+)	⑮ ↔ ⑤ (C+) (A+)	

Table A-6: Specification (For all Motor series)

Specification
With cable : 1MΩ minimum
Motor only : 2MΩ minimum

(4) **Motor and cables appearance check**

- Check for Motor damage.
- Check for cracks of cables.

Appendix 2: Initializing Driver Unit

- When troubleshooting or replacing Motor or Driver Unit, initializing Driver Unit may be necessary.
- When initializing Driver Unit, follow procedures described hereafter.
- Use Handy Terminal FHT11 for inputting command.
- Procedures

Figure A-8

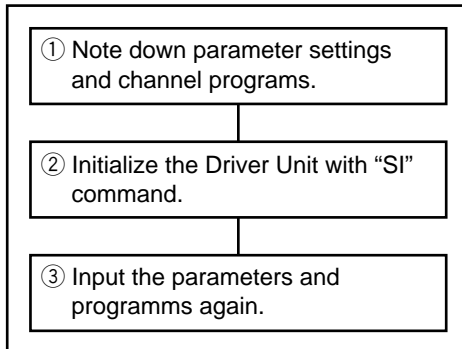

Explanations

- ① Read out parameter settings and channel programs and note down them. Especially "PA" value is important.
 - (i) Connect the Handy Terminal FHT11 to CN1 connector of the Driver Unit and turn on the power.
↓
 - (ii) Monitor the parameters with "TS0" command.
↓
 - (iii) After monitoring, turn the power off.

② Initialize the Driver Unit.

(i) Connect the Handy Terminal FHT11 to CN1 connector of the Driver Unit.



(ii) Turn on the control power only.



(iii) Input the password. When the colon “ : ” is displayed,

Press.



(iv) The Driver Unit echoes back “NSK ON”.



(v) Input “SI/AL” command.

Press.



(vi) The Driver Unit echoes back “INITIALIZE”. A colon “ : ” will be displayed to indicate completion of initializing.

③ Input the noted parameter settings and channel programs.

(i) Firstly set “PA” parameter.

- Input the password.

Press.

The Driver Unit echoes back “NSK ON”.



(ii) Press

(* must be the same data as noted.)



(iii) Set other parameters and programs accordingly.



(iv) Make sure that all parameters and programs are set properly.

- Monitor the settings with “TS0” and “TC□” commands.



(v) Turn off the power.

Appendix 3: How to Replace ESA25 Driver Unit

Danger : Make sure the power is turned off when replacing ESA25 Driver Unit.

- In the reference number of ESA25 Driver Unit, second digit from the last denotes whether it is interchangeable or not.

Figure A-9

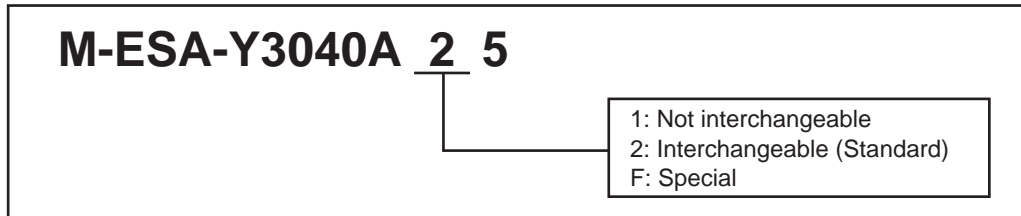

- For interchangeable (standard) Driver Unit, replace with the Driver Unit which has same reference number. Set the same parameters to new Driver Unit.
- When replacing the Driver Unit which is not interchangeable, the compensation ROM of the old Driver Unit must be transferred to the new Driver Unit. When transferring the ROM, the Driver Unit must be disassembled. To disassemble the Driver Unit, follow the procedures described hereafter.
 - For a special Driver Unit, contact your local NSK representative.
 - Before replacing the Driver Unit, record all parameters and channel programs. The record list is provided in the last page of this manual.
 - Especially, following items shall be recorded.
 - PA, VG, VI, PG, CO, MA, MV, and HO
 - Programs and other settings in channels.
 - When replacing Driver Unit, following tools and Handy Terminal FHT11 are necessary.
 - ① A screwdriver (cross recessed, 4mm)
 - ② A ROM remover

Dissemble ESA25 Driver Unit

1. Remove side panel.

Figure A-10

- Unfasten screws.
 - Top and bottom (2 places each, countersunk head)
 - Front panel (2 places, countersunk head, black oxide)

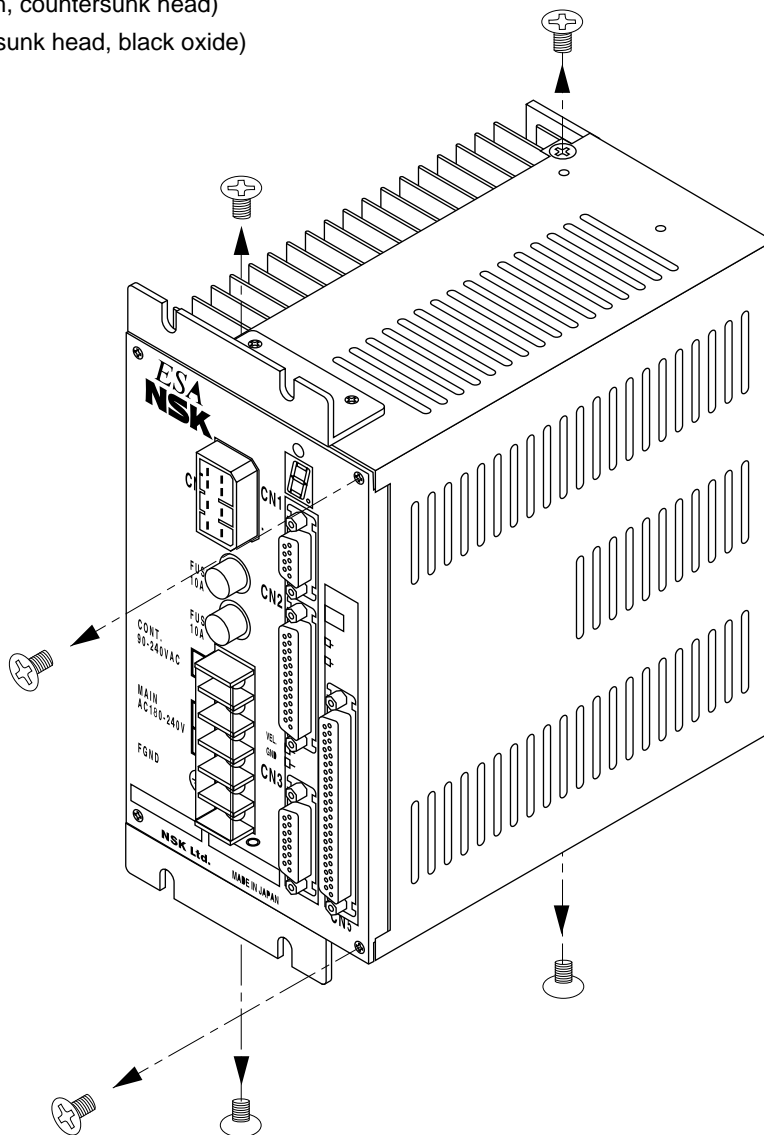
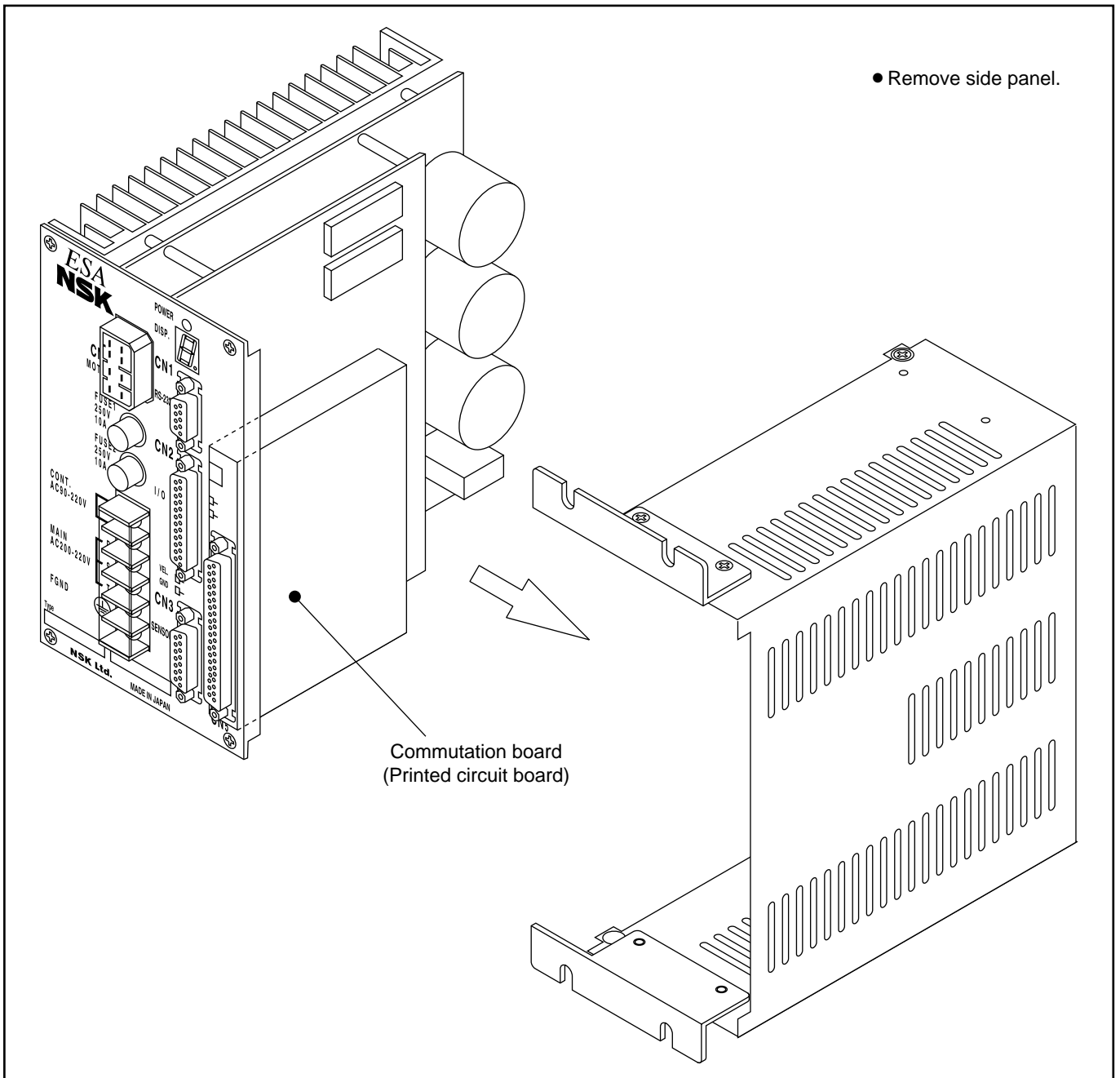

Figure A-11



2. Remove the compensation ROM (U21) from the commutation board of old Driver Unit.
(Use a ROM remover.)

Figure A-12

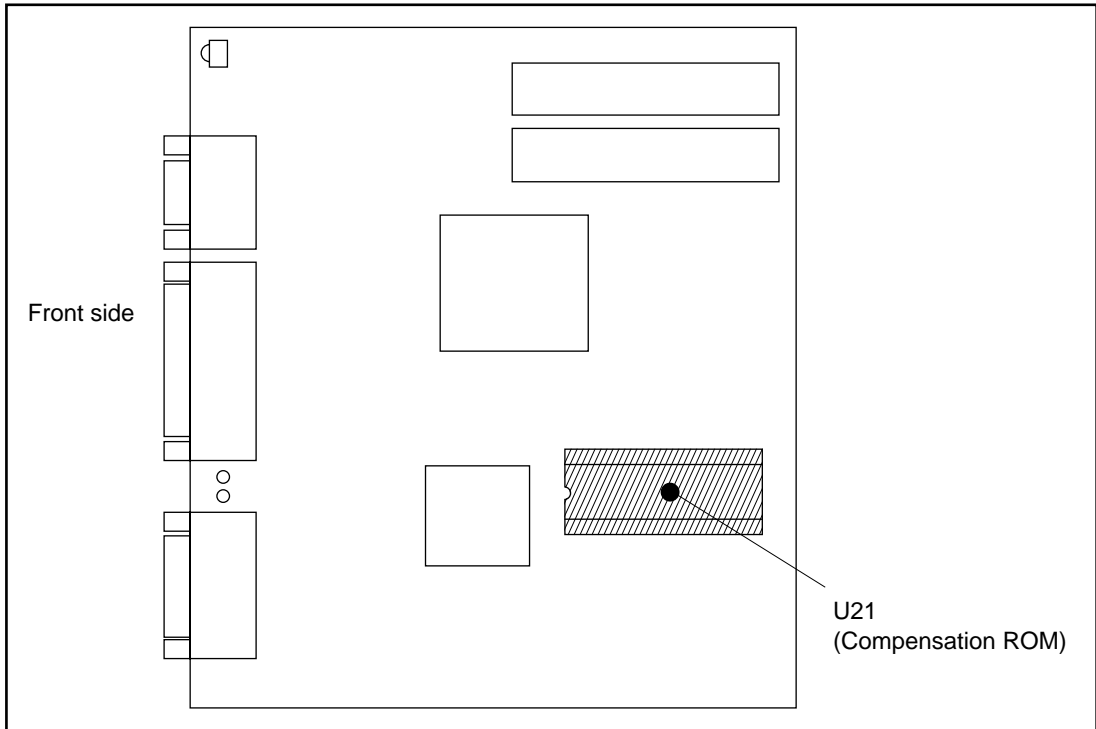
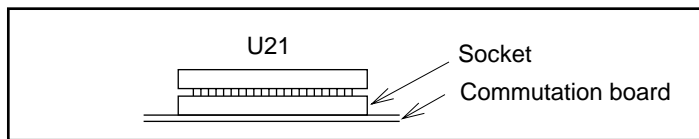

Figure A-13



3. Insert the ROM to new Driver Unit commutation board.

- Be careful of the orientation of the ROM. Make sure the ROM is securely set to the socket.

Figure A-14

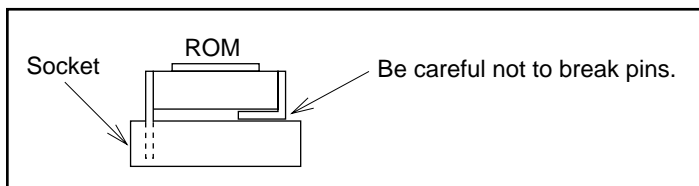
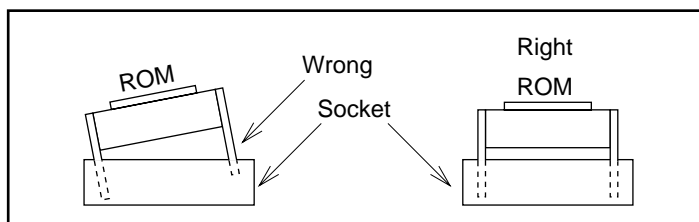

Figure A-15



4. Assemble the side panel

Figure A-16

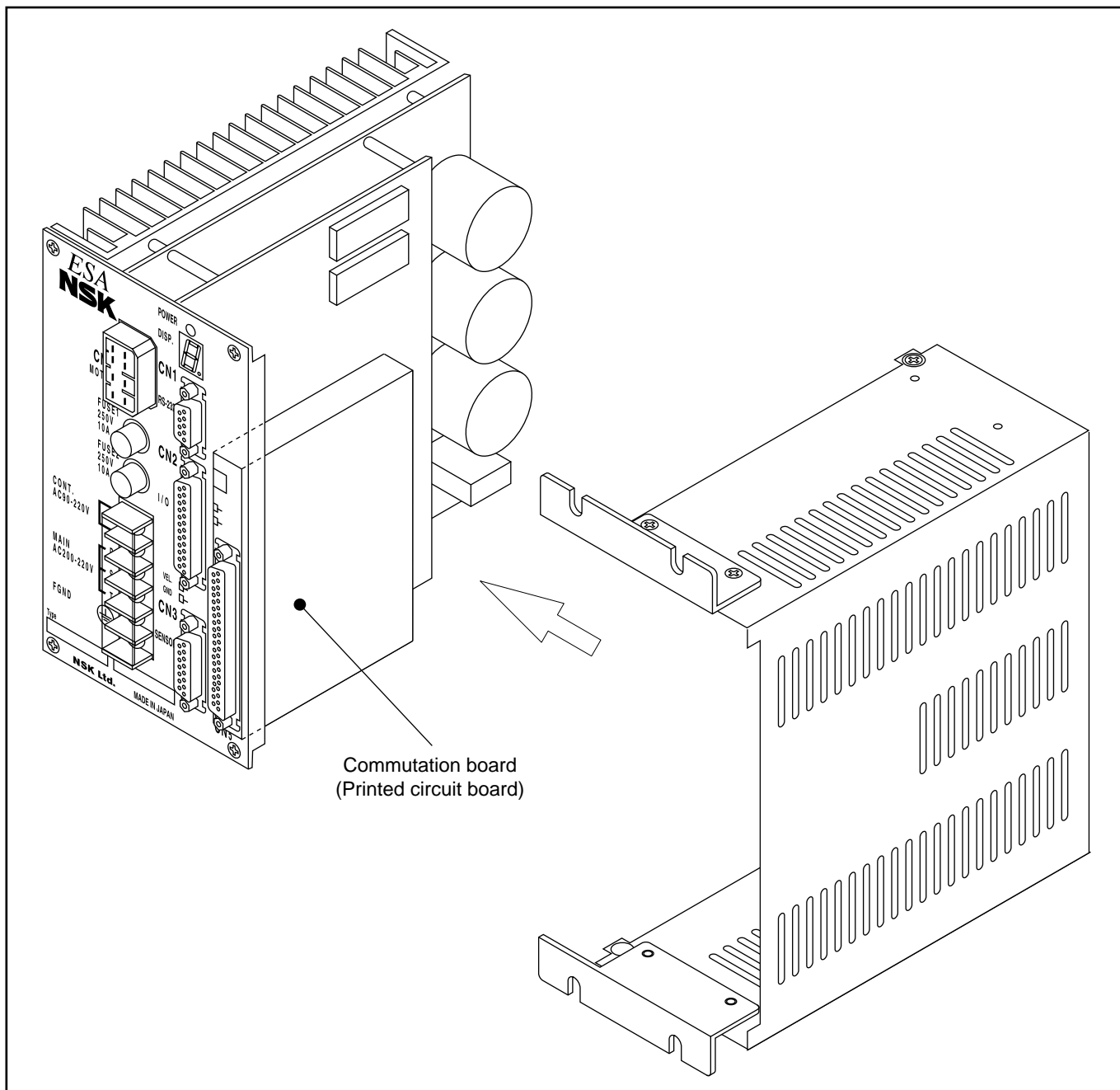
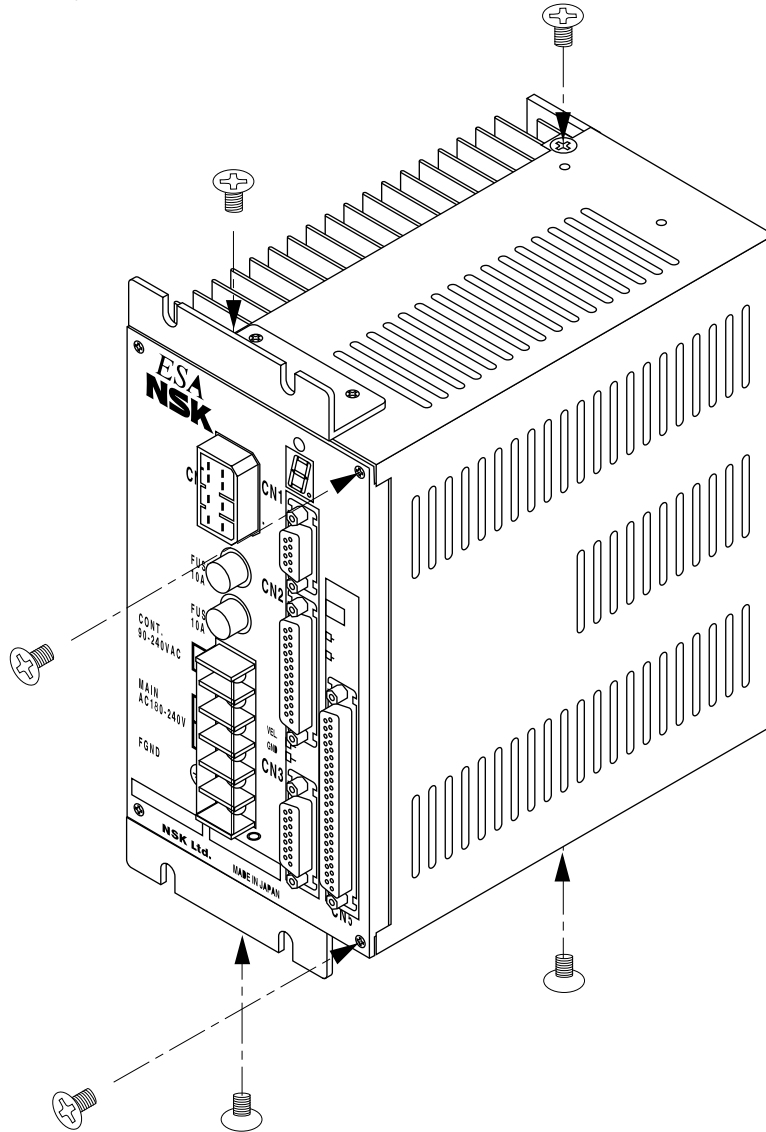

Figure A-17

- Fasten all screws securely.



5. After replacing the compensation ROM, initialize new Driver Unit.

- ① Connect Handy Terminal FHT11 to CN1 connector.
- ② Turn on the control power only.
(Control power input ports are indicated as “CONT” on the terminal block.)
 - If the main and control power can not be turned on and off separately, disconnect CN2 connector. If CN2 connector is not disconnected, the parameters can not be input properly and the Motor may run away. (Make sure that CN2 connector is disconnected.)

- ③ When control power is turned on, Handy Terminal displays “NSK MEGATORQUE ●●●”.

- After the display shows a colon “:”, input

and

.

Initialization will take about 30 seconds.

- ④ After the display shows a colon “:”, log in all parameters and channel program referring the recorded value and settings.

Figure A-19

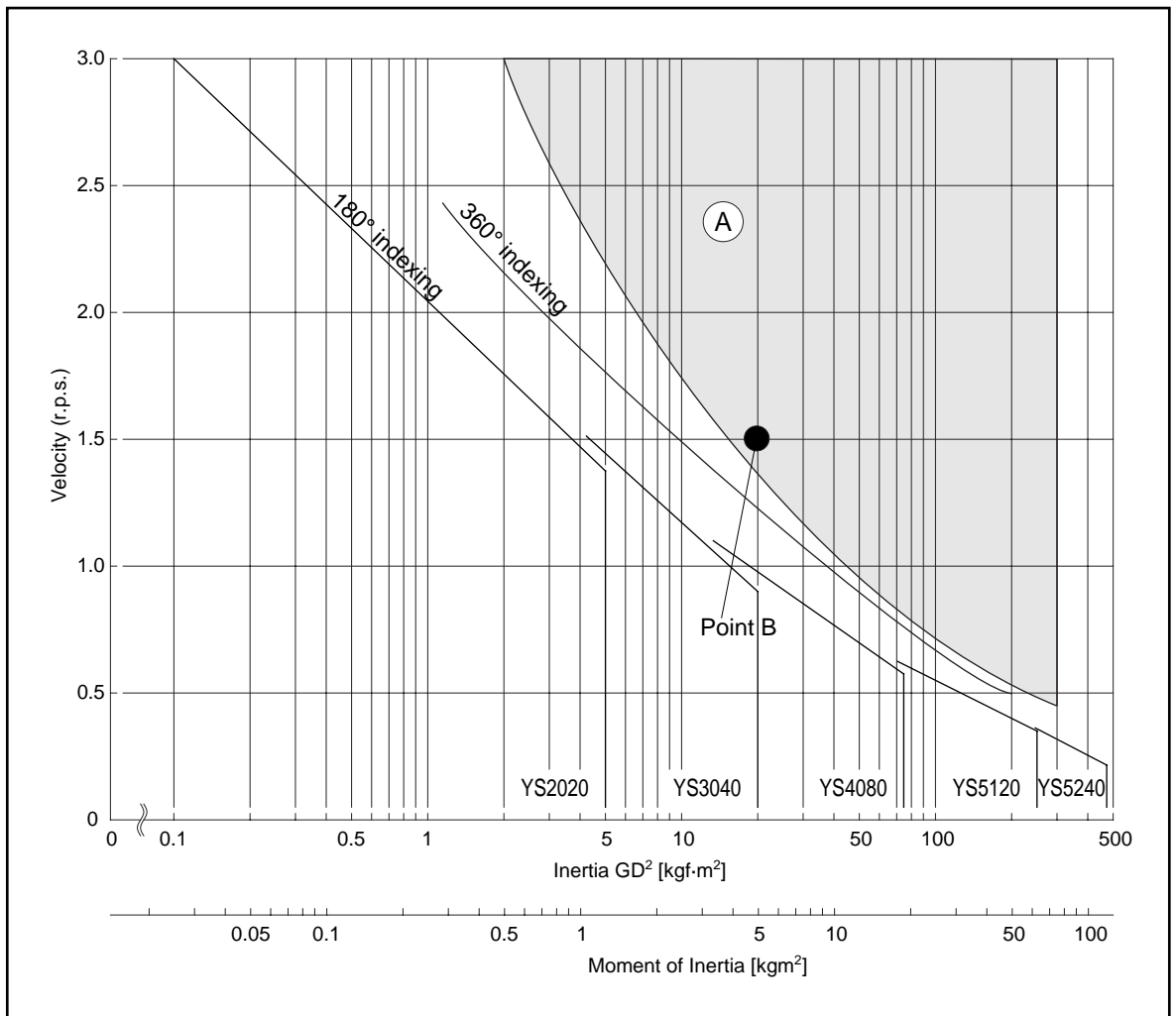

- Consult to NSK for the recommendations in other cases.

Appendix 5: Brake Built in YS Series Motor

1. Specifications

Table A-7

Motor type	Brake type	Staic friction torque (N·m)	Capacity (W)	Coil resistance (Ω)
YS2020	RNB2K	20	17	477
YS3040	RNB4K	40	23	352
YS4080	RNB8K	80	30	270
YS5120	RNB12K	120	33	245

Rated voltage : DC90V Overexertion : DC180V, 0.3 sec
Insulation class : B grade Friction material : None-asbestos

2. Construction and Operation

- The RNB brake comprises 12 parts as shown in Figures A-20~A-23.
- The armature assembly (③) is fixed with bolts (⑤) and (⑩) through the plate spring (④) in the field (①) incorporating the excitation coil.
- The armature assembly is supported with the plate spring, and is separated from the field by a narrow gap. Loaded with the coil spring (②) built in the field, the assembly presses the disk (⑦) to apply brake.
- When the coil is turned on, the field attracts the assembly against the coil spring pressure, thereby removing the pressure on the disk and releasing the brake.
- When the power supply is turned off, the coil spring force presses the armature assembly against the disk, quickly applying the brake.

Figure A-20: RNB2K

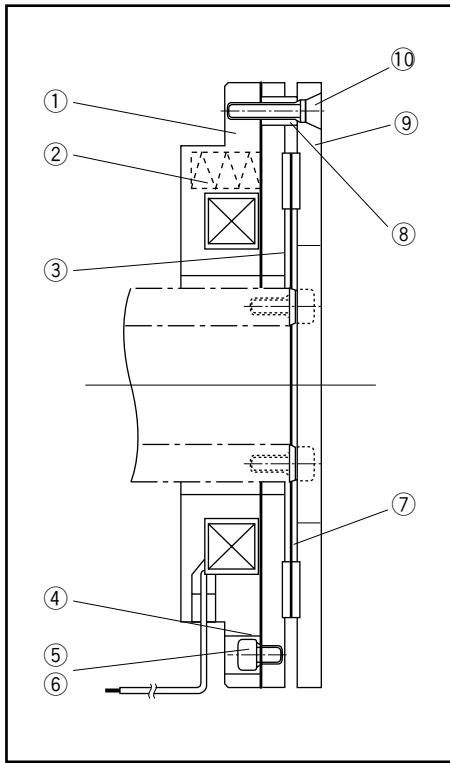

Figure A-21: RNB4K

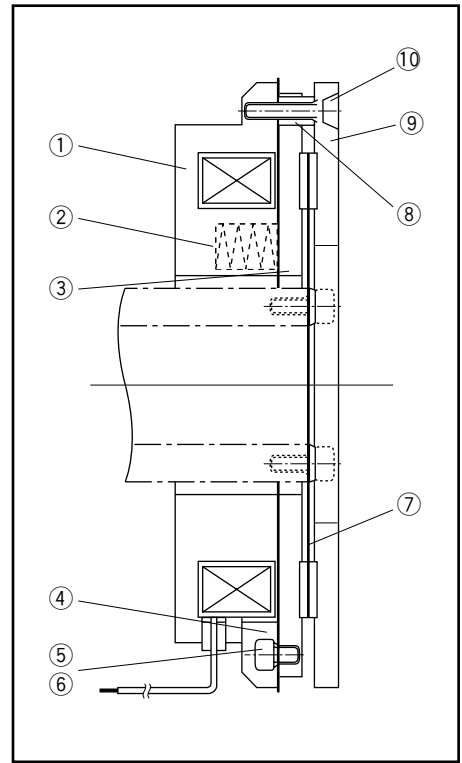

Figure A-22: RNB8K

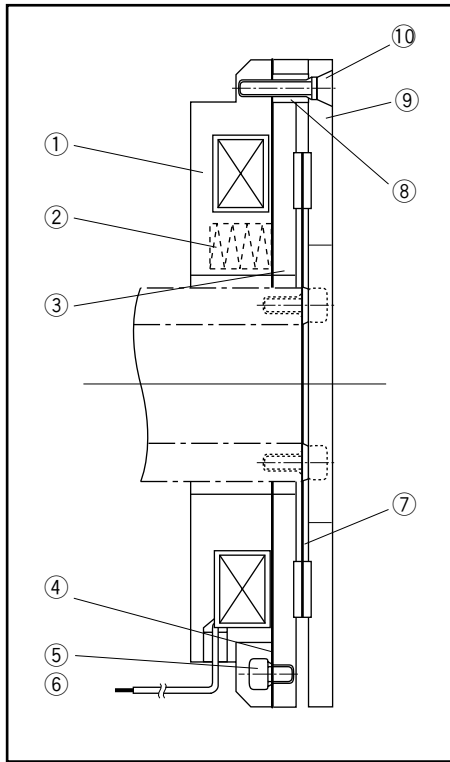

Figure A-23: RNB12K

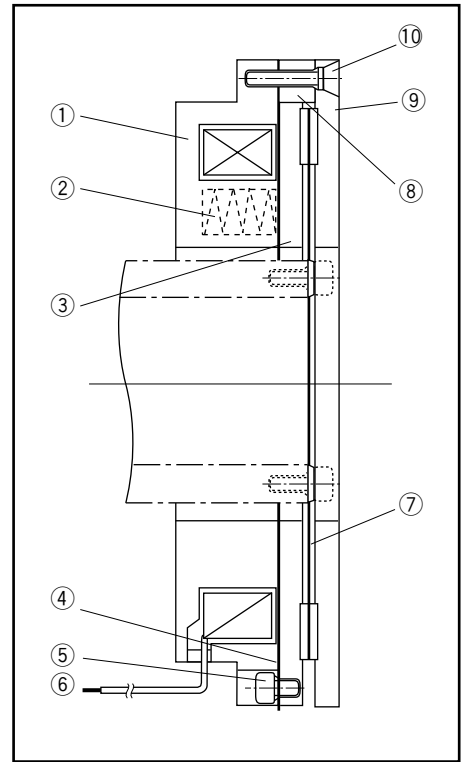

Table A-8: Parts list

Number	Name	RNB 2K	RNB 4K	RNB 8K	RNB 12K
①	Field	1	1	1	1
②	Coil spring	9	6	8	8
③	Armature assembly	1	1	1	1
④	Plate spring	1	1	1	1
⑤	Bolt	Hex. socket cap bolt 3	Hex. socket cap bolt 3	Hex. socket cap bolt 3	Hex. socket cap bolt 3
⑥	Safety spring washer	3	3	3	3
⑦	Disk	1	1	1	1
⑧	Collar	3	3	6	6
⑨	Side plate assembly	1	1	1	1
⑩	Hex. socket countersunk head screw	3	3	6	6
⑪	Shim (accessory: 0.3 mm thick)	2	2	2	2
⑫	Shim (accessory: 0.1 mm thick)	6	6	6	6

3. Handling precautions

- (1) This brake is dry type. Its torque will decrease when the friction surface is soiled with oil. Use care never to allow oil to enter it.
- (2) The electromagnetic brake uses many mild materials. Use care not to hit or drop the brake, or apply excessive force to it, otherwise indented or deformed brake could malfunction or have insufficient torque.
- (3) Do not pull or acutely bend the lead wire, or do not hang the brake by the lead wire.

4. Assembling precautions

- (1) Mount the brake in the field with a concentricity of 0.15 TIR or less and squareness of 0.05 TIR or less, against the field coupling shaft.
- (2) After installing the field, with the armature assembly attracted, adjust such that the disk is provided with equal gaps at both ends using the accompanying shims ⑪, ⑫, and fix the assembly to the coupling shaft with bolts. Do not press the shaft excessively in the axial direction, otherwise the disk could be deformed.
- (3) After mounting the disk, check that it has no backlash in the axial direction.
- (4) Tighten the bolts securely so that they will not be loosened by the vibration of the machine.
- (5) This brake is a dry type. Its torque will decrease when the friction surface is soiled with oil or water. Provide the brake with a cover if it is likely to be soiled with oil, water, or dust.

5. Check List before Operation

- (1) Is the brake securely fastened ?
- (2) Are gaps of both sides of the disk equal when the armature assembly is attracted ?
- (3) Make sure that the enough power voltage is supplied.
 - If the power supply cable is too long, voltage may be lowered due the cable's resistance, even specified power voltage is supplied. Check voltage at the brake lead wire after power is turned on.
- (4) Make sure that the armature assembly is attracted and released smoothly when the switch is on and off.
- (5) RNB type brake is basically designed holding purpose only. Do not use to brake continuously rotating object, other than emergency use.

6. Maintenance

- (1) This brake is intended to be used dry and, therefore never allow oil to enter it. If oil is entered, wipe it off using alcohol, wash the friction surface of disk and dry it before the use.
- (2) Time of releasing brake varies with exciting voltage because this electromagnetic brake is a negative operation type (spring close type). If the voltage is too low, brake cannot be released. Make sure to supply required voltage.
- (3) Check if there is a loose bolt.
- (4) To release the brake in case of power failure or abnormality in the Driver Unit, use bolts to push the armature assembly.

7. Manual Release of Brake

- Insert manual brake releasing bolts to 3 tap holes of the side plate, then screw them alternatively to press the armature assembly to the field side to release the brake.
- Use a care to screw the bolts alternatively to push the armature assembly evenly.

Table A-9

Type	RNB2K	RNB4K	TNB8K	RNB12K
Manual release bolt	M5	M5	M6	M6

8. Troubleshooting

- When the brake does not perform as intended, check followings.

● Brake is slipping.

- (1) Is the friction plate soiled with oil?
- (2) Is temperature of the brake too high? (over 100 °C)
- (3) Is excessive load applied to the machine?

● Sluggish operation of the brake

- (1) Is sufficient voltage being supplied?
- (2) Is the friction plate worn out ? (too much gap)
- (3) Is brake temperature too high? (over 100 °C)

● The brake does not operate entirely.

- (1) Breakage of coil and/or lead wire
- (2) Electrical circuit failure
- (3) Too much gap of the friction plate because of wear?
- (4) Is sufficient voltage being supplied?

Appendix 6: Parameter - Program Setting List

Reference No. : _____

S/N : _____

Parameter List

● A blank part remains the shipping set.

Date : _____

Parameter	Setting		Parameter	Setting		Parameter	Setting	
	Shipping set	Current setting		Shipping set	Current setting		Shipping set	Current setting
PG	0.1		PC	0		OL	*	
VG	1.0		RR	Å 1		RC	*	
VI	1.0		FD	0		LR	0	
VM	1		FZ	0		AB	X0X0XXXX	
LG	50		FR	0		NW	2	
TL	100		PS	1		MM	1	
FO	0		DI	0		BM	1	
FP	0		OTP	0		CM	0	
FS	0		OTM	0		AN	0	
NP	0		MV	1		WM	0	
DBP	0		MA	1		LO	0	
DBA	0		JV	0.1		SG	0	
ILV	100		JA	1		MT	*	
FF	0		HV	0.2		RI	*	
FC	0		HA	1		ZP	1.00	
CO	50000		HZ	0.01		ZV	1.4	
IN	100		OS	4		SL	3	
IS	0		HD	1		AC	1	
FW	1		HO	0		AGV	1	
CR	X1		PA	700		AGT	1	

(*: Setting differs with Motor size.)

Reference No. : _____

S/N : _____

Channel Program

● A blank part is not programmed.

Data :

CH	Program	CH	Program	CH	Program	CH	Program
0	Command : CV : CA :	16	Command : CV : CA :	32	Command : CV : CA :	48	Command : CV : CA :
1	Command : CV : CA :	17	Command : CV : CA :	33	Command : CV : CA :	49	Command : CV : CA :
2	Command : CV : CA :	18	Command : CV : CA :	34	Command : CV : CA :	50	Command : CV : CA :
3	Command : CV : CA :	19	Command : CV : CA :	35	Command : CV : CA :	51	Command : CV : CA :
4	Command : CV : CA :	20	Command : CV : CA :	36	Command : CV : CA :	52	Command : CV : CA :
5	Command : CV : CA :	21	Command : CV : CA :	37	Command : CV : CA :	53	Command : CV : CA :
6	Command : CV : CA :	22	Command : CV : CA :	38	Command : CV : CA :	54	Command : CV : CA :
7	Command : CV : CA :	23	Command : CV : CA :	39	Command : CV : CA :	55	Command : CV : CA :
8	Command : CV : CA :	24	Command : CV : CA :	40	Command : CV : CA :	56	Command : CV : CA :
9	Command : CV : CA :	25	Command : CV : CA :	41	Command : CV : CA :	57	Command : CV : CA :
10	Command : CV : CA :	26	Command : CV : CA :	42	Command : CV : CA :	58	Command : CV : CA :
11	Command : CV : CA :	27	Command : CV : CA :	43	Command : CV : CA :	59	Command : CV : CA :
12	Command : CV : CA :	28	Command : CV : CA :	44	Command : CV : CA :	60	Command : CV : CA :
13	Command : CV : CA :	29	Command : CV : CA :	45	Command : CV : CA :	61	Command : CV : CA :
14	Command : CV : CA :	30	Command : CV : CA :	46	Command : CV : CA :	62	Command : CV : CA :
15	Command : CV : CA :	31	Command : CV : CA :	47	Command : CV : CA :	63	Command : CV : CA :

(Blank Page)

World-wide Manufacturing and Marketing Organization

NSK Ltd. INTERNATIONAL DIVISION

JAPAN: Tokyo Phone: 03-3779-7120

NSK CORPORATION

U.S.A.: Ann Arbor Phone: 313-761-9500

[Precision Products Division]

U.S.A. : Chicago Phone: 708-924-8000

: Los Angeles Phone: 213-926-3578

: Ann Arbor Phone: 313-761-9500

NSK-RHP CANADA INC.

CANADA : Toront Phone: 905-890-0740

: Edomonton Phone: 403-434-3417

: Montreal Phone: 514-735-5446

: Vancouver Phone: 604-229-1151

NSK RODAMIENTOS MEXICANA, S.A. DE C.V.

MEXICO: Mexico City Phone: 5-301-2741,5-301-3115

NSK DO BRASIL INDUSTRIA E COMÉRCIO DE ROLAMENTOS LTDA.

BRASIL : São Paulo Phone: 001-269-4700

: Porto Alegre Phone: 051-222-1324

: Belo Horizonte Phone: 031-224-2508

NSK-RHP UK LTD

ENGLAND : Ruddington Phone: 0115-936-6600

NSK-RHP DEUTSCHLAND G.m.b.H

GERMANY : Düsseldorf Phone: 02102-4810

: Frankfurt Phone: 06105-21016

: Stuttgart Phone: 0711-79082-0

: Leipzig Phone: 0341-5631241-242

NSK-RHP FRANCE S.A.

FRANCE : Paris Phone:1.30.57.39.39

: Lyon Phone: 72.15.29.00

NSK-RHP NEDERLAND B.V.

NETHERLAND: Amsterdam Phone: 020-6470711

NSK-RHP ITALIA S.p.A.

ITALIA: Milano Phone: 02-99025771

NSK-RHP AUSTRALIA PTY, LTD.

AUSTRALIA : Melbourne Phone: 03-9764-8302

: Sydney Phone: 02-893-8322

: Brisbane Phone: 07-3393-1388

: Adelaide Phone: 08-373-4811

: Perth Phone: 09-434-1311

NSK-RHP BEARING NEW ZEALAND LTD.

NEW ZEALAND: Auckland Phone: 09-276-4992

NSK SINGAPORE (PRIVATE) LTD.

SINGAPORE: Singapore Phone: 2781711

NSK BEARINGS (THAILAND) CO., LTD.

THAILAND : Bangkok Phone: 2-6412150-60

: Chiang mai Phone: 053-246993-4

HANWHA NSK PRECISION CO., LTD.

KOREA : Seoul Phone: 02-3400-5000

TAIWAN NSK PRECISION CO., LTD.

TAIWAN: Taipei Phone: 02-591-0656

NSK REPRESENTATIVE OFFICE

KOREA: Seoul Phone: 02-779-6300

INDONESIA: Jakarta Phone: 021-314-1708

MEGATORQUE® MOTOR SYSTEM

User's Manual (ESA25 Driver Unit System)

Document Number: C20058-02

June 4, 1997	1st Edition 1st Printing
September 1, 1997	1st Edition 2nd Printing
February 2, 1998	1st Edition 3rd Printing
April 1, 1998	1st Edition 4th Printing
May 13, 1998	1st Edition 5th Printing
October 19, 1998	1st Edition 6th Printing
August 23, 1999	2nd Edition 1st Printing
April 4, 2000	2nd Edition 2nd Printing

NSK Ltd.

NSK